

# AI FOR LIFE: UTILIZING EMOTION INTELLIGENCE, IOT, AND DEEP LEARNING TO PREVENT SUICIDES AND OPTIMIZE SPEED CONTROL

## Abstract

In recent times, a concerning number of suicides involve hanging from ceiling fans. Simultaneously, despite advancements in power generation methods, power scarcity remains a persistent issue. Addressing these challenges requires innovative approaches. This paper presents a comprehensive approach to address of above two critical situations. The envisioned design comprises a ceiling fan integrated with a comprehensive set of hardware components. These components include a microcontroller, a Passive Infrared (PIR) sensor, a Force sensor, a Buzzer, a GSM module, a manual switch, a DC motor, and a camera for capturing the person's emotional state. When someone tries to hang themselves, a Force sensor identifies if their weight surpasses a specified threshold. If exceeded, a mechanism triggers. This mechanism employs a spring-based disengagement, causing a rod to separate from the fan. Consequently, the person is gently lowered to the ground, prioritizing their safety. Simultaneously, an alarm activates, and the GSM module sends alerts to designated guardians. Additionally, an embedded camera captures the person's emotional state, which is analysed using deep learning techniques. This analysis then informs an automatic adjustment of the fan's speed, tailored to the individual's mood. This integrated system not only safeguards lives but also enhances user comfort based on emotional cues.

**Keywords:** Emotion intelligence, Deep learning, IoT, Ceiling Fan.

## Authors

### **Rajendra Prasad K**

Assistant Professor  
Department of CSE(Data Science)  
Vignan Institute of Technology and Science  
Hyderabad, Telangana, India.  
vitscsedspro@gmail.com

### **P. Janaki**

Assistant Professor  
Department of CSE(Data Science)  
Vignan Institute of Technology and Science  
Hyderabad, Telangana, India.  
janakicse513@gmail.com,

### **V. Bhulakshmi**

Assistant Professor  
Department of CSE(Data Science)  
Vignan Institute of Technology and Science  
Hyderabad, Telangana, India.  
varipalli.bhulakshmi19@gmail.com,

### **Mr. JVNSP.Ganesh**

Assistant Professor  
Department of CSE(Data Science)  
Vignan Institute of Technology and Science  
Hyderabad, Telangana, India.  
ganeshjuturi2@gmail.com

## AI FOR LIFE: UTILIZING EMOTION INTELLIGENCE, IOT, AND DEEP LEARNING TO PREVENT SUICIDES AND OPTIMIZE SPEED CONTROL

### I. INTRODUCTION

The prevalence of suicides, particularly those involving hanging, presents a concerning trend as indicated by National Crime Records Bureau (NCRB) data, with hanging accounting for 30% of suicide cases. An alarming observation is the occurrence of these tragic incidents among college and university students within hostel environments, where ceiling fans are often the chosen method. This method's popularity underlines its widespread adoption, emphasizing the urgent need to address this challenge. Furthermore, the escalating instances of hanging-related suicides, primarily among young adults, have raised concerns. The impact on society, emotionally, socially, and economically, is substantial, given that a significant portion of these incidents involves individuals under the age of 44. Effectively curbing these incidents remains a formidable task for public health authorities, demanding innovative solutions. Concurrently, the issue of power consumption optimization is a persistent concern. In hospital settings, patients' emotions and moods are influenced by illness, necessitating adaptable fan speeds based on individual requirements. During nighttime hours, when nursing staff availability is limited, ensuring optimal fan speed for patient comfort becomes challenging.

This paper overarching objective is two-fold: to mitigate suicide attempts facilitated by ceiling fans and to optimize power consumption by regulating fan speeds. By integrating advanced technologies such as Emotion Intelligence, IoT systems, and deep learning techniques, the design aims to effectively detect and prevent hanging-related suicide attempts. Simultaneously, it addresses energy efficiency concerns by automatically adjusting fan speeds based on patients' needs, particularly in healthcare settings. By addressing these pressing challenges, the paper strives to contribute to a safer environment and a more sustainable energy landscape. It emphasizes the role of technology in safeguarding lives, promoting mental health, and conserving resources, underscoring the potential for innovation to positively impact society's well-being and progress.

The paper references several notable contributions in the field of intelligent systems, IoT applications, and deep learning methodologies. These studies collectively demonstrate the extensive range of applications and innovations that have been achieved by harnessing cutting-edge technologies. Narasapur et al. [1] introduced an anti-suicide ceiling fan leveraging the RENESAS microcontroller and CubeSuite+, prioritizing life-saving measures. Budiman et al. [2] devised an intelligent AC conditioning control system, dynamically adjusting settings based on occupancy and activity levels. Yammen et al. [3] proposed a smart fan controlled via a handheld device, while Ibne et al. [4] presented an IoT-based home appliance protection system. Ragul et al. [5] designed a smart remote for ceiling fan control, and Prasad et al. [6] developed an Android-based home automation system encompassing switches, AC units, and lighting control. Maity [7] created a Blynk app for efficient home appliance control, and Michael et al. [8] crafted a body temperature-linked AC control system. Zhang [9] contributed an AC energy-saving control system incorporating IoT and Fuzzy algorithm, and Kariippanon et al. [10] addressed the complexities of hanging by ceiling fans in three different scenarios. Cheng and Lee [11] emphasized sensor-enabled AC control, while Mata et al. [12] introduced an energy-saving concept utilizing image depth sensors for human activity recognition. Tonoy et al. [13] pioneered an intelligent IoT home automation system utilizing machine learning, and Smutny [14] discussed smart temperature sensors' utility in various control systems. Medus et al. [15] proposed CNN-based faulty food

## AI FOR LIFE: UTILIZING EMOTION INTELLIGENCE, IOT, AND DEEP LEARNING TO PREVENT SUICIDES AND OPTIMIZE SPEED CONTROL

detection, and Badlani et al. [16] focused on CNN for pneumonia detection. Baranwal et al. [17] evaluated MRI brain tumor classification performance using CNN and SVM, while Sharma and Phonsa [18] advanced content-based image retrieval techniques through CNN. Collectively, these studies represent an array of advancements that underscore the potential of technology to enhance safety, comfort, and efficiency across diverse domains, showcasing the transformative influence of AI, IoT, and deep learning techniques in modern-day applications.

### II. PROPOSED METHOD

The envisioned design comprises a ceiling fan integrated with a comprehensive set of hardware components. These components include a microcontroller, a Passive Infrared (PIR) sensor, a Force sensor, a Buzzer, a GSM module, a manual switch, a DC motor, and a camera for capturing the person's emotional state. The core of the system is the RENESAS microcontroller, which serves as the central processing unit, coordinating the interactions among various components. The PIR sensor detects human presence in the vicinity, enabling the system to activate based on occupancy. The Force sensor contributes to understanding the user's interaction with the fan. A Buzzer provides auditory cues, alerting users to system status changes or critical events. The GSM module enables communication through cellular networks, facilitating alerts and notifications to be sent to designated contacts or authorities in case of emergencies. For manual control, a physical switch is incorporated to offer a traditional means of fan operation. The DC motor drives the fan's rotation and speed adjustments, while a camera captures the person's emotional expressions and cues, providing valuable input for the Emotion Intelligence system.

By combining these hardware elements, the proposed design creates a comprehensive and responsive ecosystem. It intelligently adapts fan operation based on user presence and preferences, alerts caregivers or authorities in critical situations, and leverages facial cues to understand and respond to the user's emotional state. This innovative integration of technology not only enhances comfort and safety but also demonstrates the potential of IoT and Emotion Intelligence in shaping future human-centric systems.

The captured emotional state of an individual is analyzed using Convolutional Neural Networks (CNN), a powerful deep learning technique. This analysis categorizes the person's emotion, providing crucial insights. Depending on the detected emotion, the controller sends signals to the fan regulator, thus managing the fan's speed accordingly. However, the significance of predicting the person's emotional state extends beyond just fan control. Utilizing this emotion prediction, the system can potentially discern if the person is exhibiting signs of suicidal tendencies. The comprehensive analysis extends to identifying behavioral patterns that might indicate a suicide attempt. This advanced level of understanding aids in timely intervention and support.

In summary, the paper integrates cutting-edge technology to gauge emotions through CNN analysis, enabling automatic fan speed adjustments based on emotional cues. Additionally, this prediction model carries the potential to identify distress and intervene in critical situations, aligning with the broader goal of not only enhancing comfort but also saving lives.

AI FOR LIFE: UTILIZING EMOTION INTELLIGENCE, IOT, AND DEEP LEARNING  
TO PREVENT SUICIDES AND OPTIMIZE SPEED CONTROL

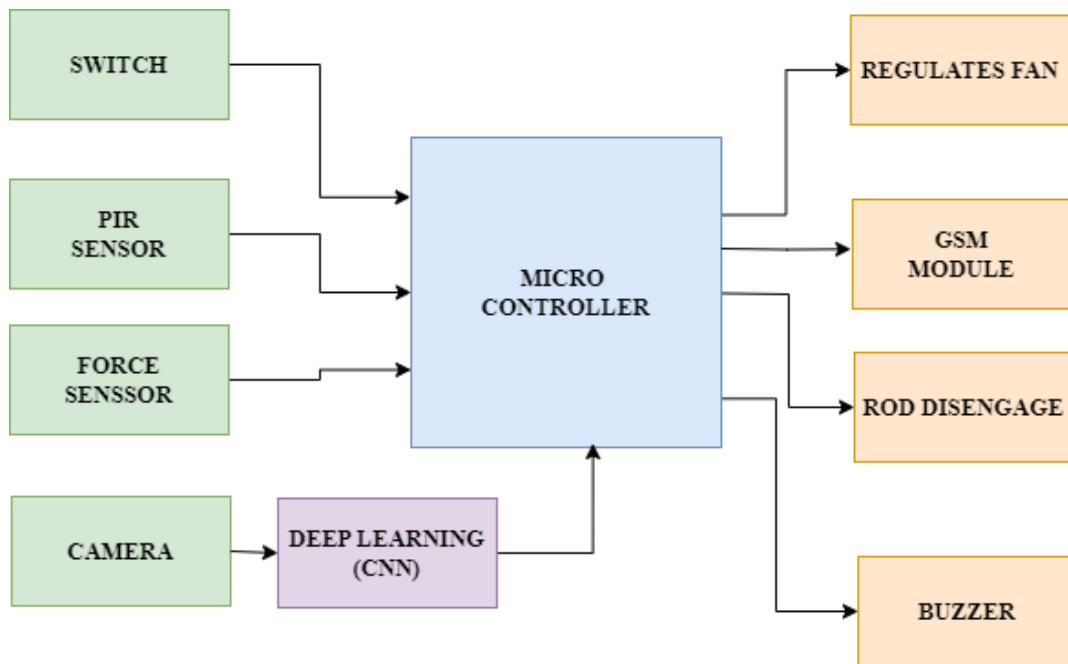

**Figure 1:** Block diagram of ceiling fan based system to avoid suicide by hanging and speed control by mood.

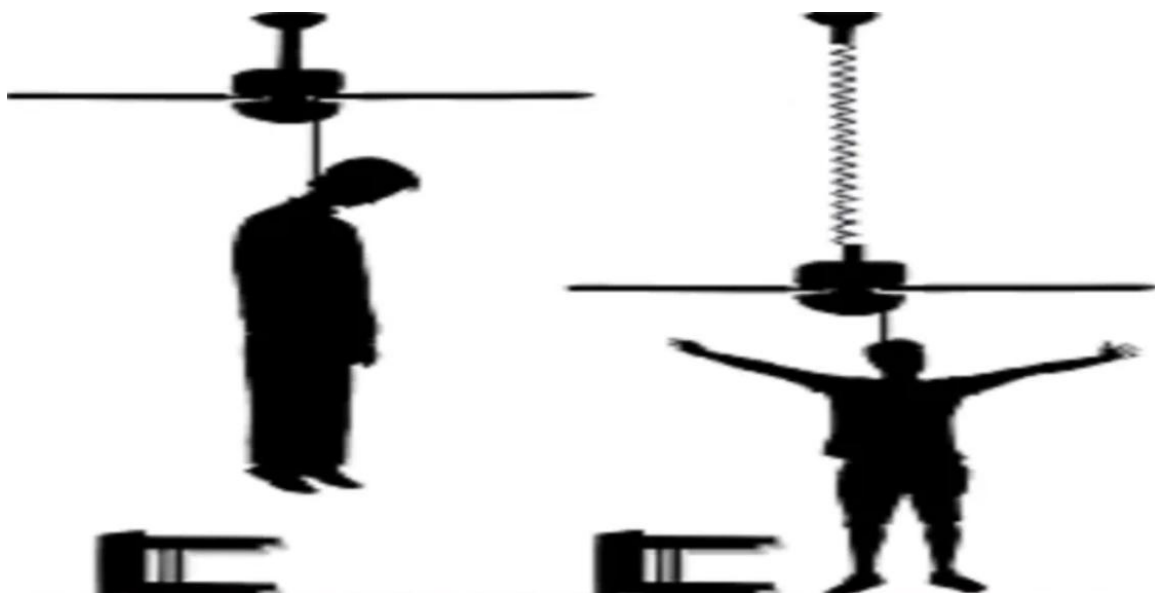
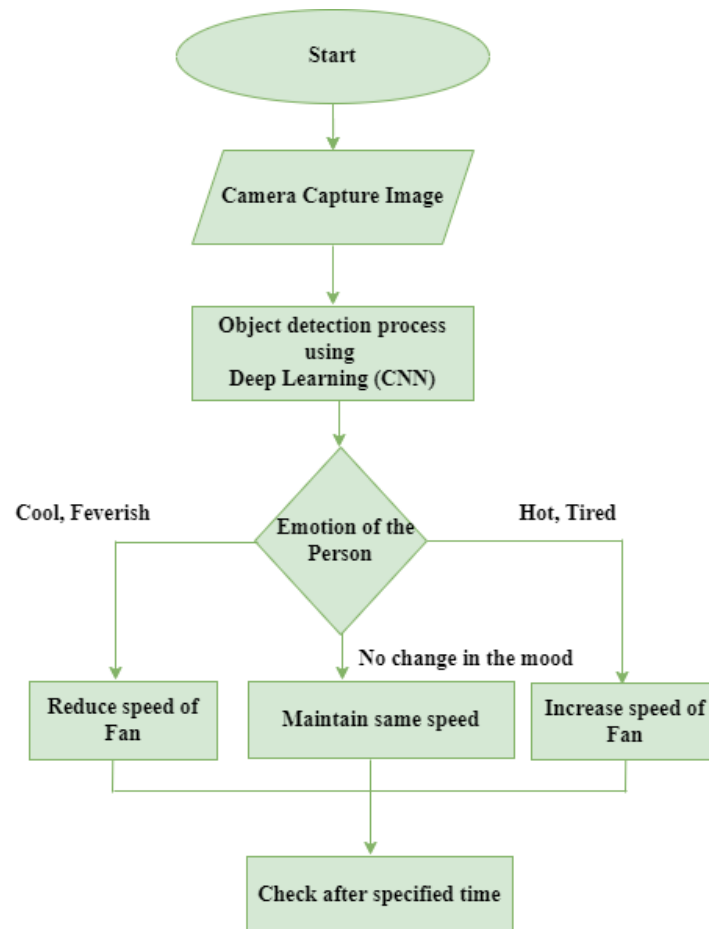

**Figure 2:** The mechanism of rod to disengage from fan

The block diagram, depicted in Figure 1, delineates the controller's left side as input components and its right side as output components. The operation begins with PIR and Force sensors, which collaborate to ascertain if an individual has attempted suicide through hanging. When the Force sensor detects weight surpassing the predetermined threshold, it transmits a signal to the controller. In response to this signal, the controller activates various output components to execute a series of actions. A distress alert is immediately sounded by activating the buzzer, alerting people in the vicinity to the critical situation. Simultaneously,

## AI FOR LIFE: UTILIZING EMOTION INTELLIGENCE, IOT, AND DEEP LEARNING TO PREVENT SUICIDES AND OPTIMIZE SPEED CONTROL

the controller engages the GSM module, sending alert messages to designated guardians, thereby enabling swift intervention. Furthermore, the mechanism designed for safety is initiated by the controller. A spring-based mechanism is activated, causing the rod to disengage from the fan as shown in Figure 2. This action ensures a safe landing for the individual attempting self-harm, thereby preventing harm. And altering surrounding people by alarm and sending notification message to registered number. In essence, the block diagram captures the seamless interaction between input and output components. PIR and Force sensors trigger a cascade of responses, comprising alarms, notifications, and a life-saving mechanism. This integrated approach highlights technology's potential to prevent suicides and save lives, demonstrating a holistic solution driven by intelligent automation.



**Figure 3:** Flow chart of fan speed control based on person mood

The flow chart depicted in Figure 3 illustrates the process of controlling fan speed based on the person's emotional state. The sequence commences with the camera capturing the person's emotional expression. The captured emotions include feelings of cold, feverishness, heat, tension, or no discernible mood change. Subsequently, the captured images undergo categorization through Convolutional Neural Networks (CNN), an advanced deep learning technique. This categorization precisely identifies the person's emotional state from the captured images. The controller is then prompted to take action based on the recognized emotion. Activating the appropriate output component, the controller initiates the

## AI FOR LIFE: UTILIZING EMOTION INTELLIGENCE, IOT, AND DEEP LEARNING TO PREVENT SUICIDES AND OPTIMIZE SPEED CONTROL

automatic adjustment of the fan's speed. This ensures that the fan's speed is tailored to the person's emotional needs, enhancing comfort and well-being. In essence, this flow chart encapsulates the seamless process from emotion capture to automated fan speed control. By leveraging advanced technologies like CNN and IoT, the system exemplifies a responsive and intelligent solution that enhances user comfort and experience based on emotional cues.

### III. CONCLUSION

The integration of advanced technologies in the form of Emotion Intelligence, IoT, and Deep Learning holds tremendous promise in reshaping critical aspects of our lives. The paper has underscored the urgency of addressing the rising incidence of suicides, particularly those involving hanging, and the persistent challenge of power consumption optimization. Through innovative design and thoughtful implementation, a comprehensive solution has been presented that not only addresses these challenges but also aligns with the broader vision of leveraging technology for human betterment. By harnessing Emotion Intelligence, the proposed system provides an effective means to detect distress signals, intervening in life-threatening situations and potentially saving lives. The integration of IoT components such as Force sensors, PIR sensors, and GSM modules creates a responsive ecosystem that actively prevents harm and ensures timely alerts to guardians or authorities. Simultaneously, the incorporation of Deep Learning techniques, notably Convolutional Neural Networks, brings about intelligent automation in fan speed regulation. This not only optimizes energy consumption but also tailors user experiences based on emotional cues. By accurately categorizing emotions captured by cameras, the system can dynamically adjust the fan's speed, creating a personalized and comfortable environment. In effect, this paper signifies a holistic approach that extends beyond technological advancements. It speaks to the profound potential of technology to play an active role in enhancing human safety, well-being, and energy efficiency.

### REFERENCES

- [1] Narsapur, R.S., Hiremath, B., & Jayadevappa, B.M. (2019). A Novel Approach on Ceiling Fan Based System to Avoid Suicide by Hanging. *International journal of engineering research and technology*, 7.
- [2] Budiman, F., Rivai, M., BagusPrastaRaditya, I.G., Krisrenanto, D., & Amiroh, I.Z. (2018). Smart Control of Air Conditioning System Based on Number and Activity Level of Persons. *2018 International Seminar on Intelligent Technology and Its Applications (ISITIA)*, 431-436.
- [3] Yammen, S., Tang, S., & Vennapusa, M.K. (2019). IoT based speed control of Smart Fan. *2019 Joint International Conference on Digital Arts, Media and Technology with ECTI Northern Section Conference on Electrical, Electronics, Computer and Telecommunications Engineering (ECTI DAMT-NCON)*, 17-20.
- [4] IbneJoha, M., Shafiul Islam, M., & Ahamed, S. (2022). IoT-Based Smart Control and Protection System for Home Appliances. *2022 25th International Conference on Computer and Information Technology (ICCIT)*, 294-299.
- [5] Ragul, S., S, Y., Vijayabalan, V., Venkatasamy, B., Kalaivani, L., & Jeffrey Vaz, F.A. (2023). IoT based Smart Controller for Ceiling Fan. *2023 7th International Conference on Trends in Electronics and Informatics (ICOEI)*, 376-382.
- [6] Prasad, M.L., Singh, A.K., & Kumar, Y. (2022). Home Automation including Switching of appliance speed control of ac fan and brightness control of incandescent bulb. *2022 IEEE 10th Power India International Conference (PIICON)*, 1-5.
- [7] Maity, S. (2021). Iot Based Home Appliance Control System Using Proteus Simulation Software and Blynk Server. *International Journal for Research in Applied Science and Engineering Technology*.

AI FOR LIFE: UTILIZING EMOTION INTELLIGENCE, IOT, AND DEEP LEARNING  
TO PREVENT SUICIDES AND OPTIMIZE SPEED CONTROL

- [8] Michael, A.A., Abiodun, F.T., Mikail, O.O., & Ibrahim, A.A. (2014). Human Body Temperature based Air Conditioning Control System. *International journal of engineering research and technology*, 3.
- [9] Zhang, Y. (2020). Design of air conditioning energy saving control system based on Niagara Internet of things technology and fuzzy algorithm. *IOP Conference Series: Earth and Environmental Science*, 585.
- [10] Kariippanon, K.A., Wilson, C.J., McCarthy, T.J., & Kõlves, K. (2019). A Call for Preventing Suicide by Hanging from Ceiling Fans: An Interdisciplinary Research Agenda. *International Journal of Environmental Research and Public Health*, 16.
- [11] Cheng, C., & Lee, D. (2014). Smart Sensors Enable Smart Air Conditioning Control. *Sensors (Basel, Switzerland)*, 14, 11179 - 11203.
- [12] Mata, O., Méndez, J.I., Ponce, P., Peffer, T.E., Meier, A.K., & Molina, A. (2023). Energy Savings in Buildings Based on Image Depth Sensors for Human Activity Recognition. *Energies*.
- [13] Tonoy, R.B., Mahmudunnabi, Zilany, H.M., & Rahman, R.M. (2021). A Smart and Intelligent Home Automation System. *2021 IEEE 12th Annual Ubiquitous Computing, Electronics & Mobile Communication Conference (UEMCON)*, 0446-0452.
- [14] Smutný, L. (2000). Smart Temperature Sensors for Measurement and Control.
- [15] Medus, L.D., Saban, M., Francés-Víllora, J.V., Bataller-Mompeán, M., & Rosado-Muñoz, A. (2021). Hyperspectral image classification using CNN: Application to industrial food packaging. *Food Control*.
- [16] Badlani, K., Sawal, S., Nilkute, M., Belekar, S., & Nilawar, A. (2022). Pneumonia detection through Image Classification Using CNN. *International Journal of Next-Generation Computing*.
- [17] Baranwal, S.K., Jaiswal, K., Vaibhav, K., Kumar, A., & Srikantaswamy, R. (2020). Performance analysis of Brain Tumour Image Classification using CNN and SVM. *2020 Second International Conference on Inventive Research in Computing Applications (ICIRCA)*, 537-542.
- [18] Sharma, A., & Phonsa, G. (2021). Image Classification Using CNN. *SSRN Electronic Journal*.