

# INDUSTRIAL PROCESSING AND BASIC PRINCIPLES INCLUDING CRYSTALLIZATION AND LYOPHILIZATION

## Abstract

Industrial processes transform or separate raw material into pharmaceutically acceptable products like drugs and excipients. Pharmaceutical engineering is used for production of dosage forms, manufacturing of bulk drugs, production of biological and antibiotics. Several unit operations and unit process (physical and chemical) are carried in a sequential order to achieve a process efficiently and economically. In this chapter, we shall discuss in detail about two critical process namely, crystallization and lyophilization which is widely applicable in industrial processing of pharmaceuticals.

Crystallization is the process by which the particles spontaneously arrange themselves into a regular, ordered array or predictable geometric structure. Whereas Lyophilization, also known as freeze drying, is the process of removing bound water molecules as well as ice or other frozen solvents from a material through the processes of desorption and sublimation. This chapter mainly focuses on objectives and applications, the major steps and theories involved in the process, factors affecting the process, principle, working, construction, advantages and disadvantages of equipments used for Crystallization and Lyophilization respectively.

**Keywords:** Industrial Processing, Basic Principles Crystallization, Lyophilization

## Authors

**Yashoda Mariappa Hegde**  
Research Scholar  
Department of Pharmaceutics  
Swamy Vivekanandha College of  
Pharmacy  
Namakkal, Tamilnadu, India.

**Rajesh Kumar N**  
Associate Professor  
Department of Pharmaceutics  
Senghundhar College of Pharmacy  
Namakkal, Tamilnadu, India.

**Geetha Srinivas**  
Research Scholar  
Department of Pharmaceutics  
Swamy Vivekanandha College of  
Pharmacy  
Namakkal, Tamilnadu, India.

**Ms. Yashoda Mariappa Hegde**  
Research Scholar  
Department of Pharmaceutics  
Swamy Vivekanandha College of  
Pharmacy  
Namakkal, Tamilnadu, India.  
yashoda276h@gmail.com

## I. INDUSTRIAL PROCESSING AND BASIC PRINCIPLES

Pharmaceutical engineering is the study of industrial processes that transform or separate raw material into pharmaceutically acceptable products like drugs and excipients. The study of chemical engineering concepts with a focus on pharmacy is known as pharmaceutical engineering. The goal is to provide a chemical engineering methodology for processing pharmaceuticals and manufacturing bulk drugs. Following are a few examples of pharmaceutical engineering applications:

- 1. Production of Dosage Forms:** The transformation of medications into patient-friendly dose forms. For example, the production of pills, capsules, gel, and solutions from sodium diclofenac.
- 2. Manufacturing of Bulk Drugs:** Drugs are generated from chemicals. Aspirin, for instance, is produced when salicylic acid is acetylated.
- 3. Antibiotic Production:** involves fermentation technology, which uses bacteria to produce medications with the help of precursors. For instance, *Penicillium chrysogenum* and precursor phenyl acetic acid are used to generate Penicillin G.
- 4. Production of Biologicals:** Purification of pharmaceuticals from native raw materials such as minerals, plants, animals, and plants into finished goods. Examples include insulin, DNA recombinant products, and vaccines.

## II. UNIT OPERATIONS AND UNIT PROCESSES

- 1. Unit Operations:** The small numbers of distinct individual phases that make up a physical or chemical process are sometimes referred to as unit operations, and each step is part of the process. Every unit operation adheres to a certain scientific principle. Several unit operations and their underlying concepts include:
  - **Drying:** Removing liquid or moisture from solids by heat-induced evaporation is a unit operation. An illustration is the process of removing too much moisture from wet granules to produce tablets.
  - **Filtration:** It is a unit operation in which solid particles in a liquid or gaseous fluid is removed by the use of a filter medium that permits the fluid to pass through but retains the solid particles.
  - **Size Reduction:** Drugs are broken down into smaller fragments, larger chunks, or fine powder in this unit activity.
  - **Distillation:** This unit process includes heating liquid to turn it into vapour, then condensing the vapour to turn it back into liquid. An example is the process of distilling eucalyptus oil from its leaves.
  - **Size Separation:** It is a unit process in which a mixture of particles of different sizes is divided into multiple pieces using screening surfaces. Sieving, sifting, and screening are other terms for size separation.

- **Evaporation:** It involves a process by which liquid water goes directly into the vapour phase due to an increase in temperature but is usually restricted to the concentration of solutions by boiling.
2. **Unit Process:** A unit process is one in which a number of unit activities are brought together simultaneously in order to achieve the goals of a chemical or physical process.
  3. **Unit Process – Physical Process:** For example, consider the manufacture of common salt

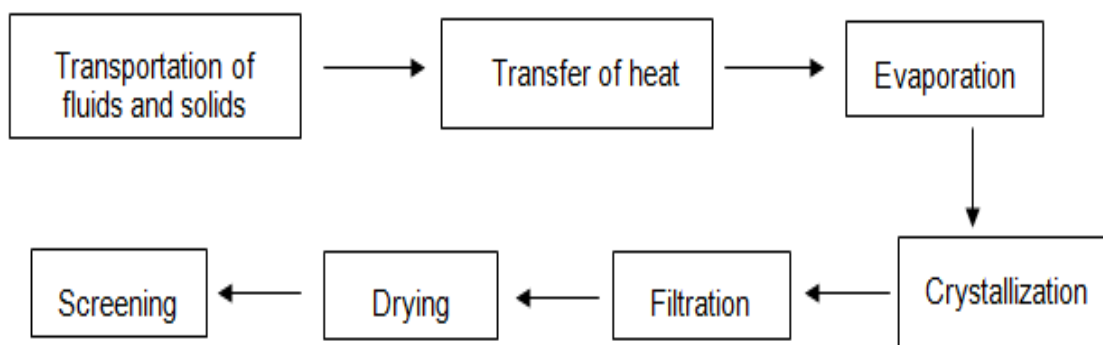

4. **Unit Process – Chemical Process:** Consider the sequence of reactions for the production of paracetamol from benzene.

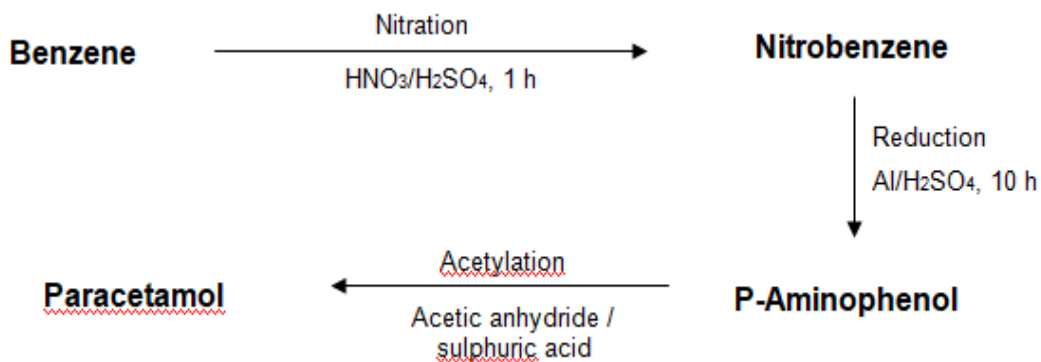

Nitration, reduction, and acetylation are the three unit processes that are involved in the previously mentioned process. Numerous unit activities are contained in each unit process in turn. For instance, the unit activities involved in the nitration of benzene to nitrobenzene are:

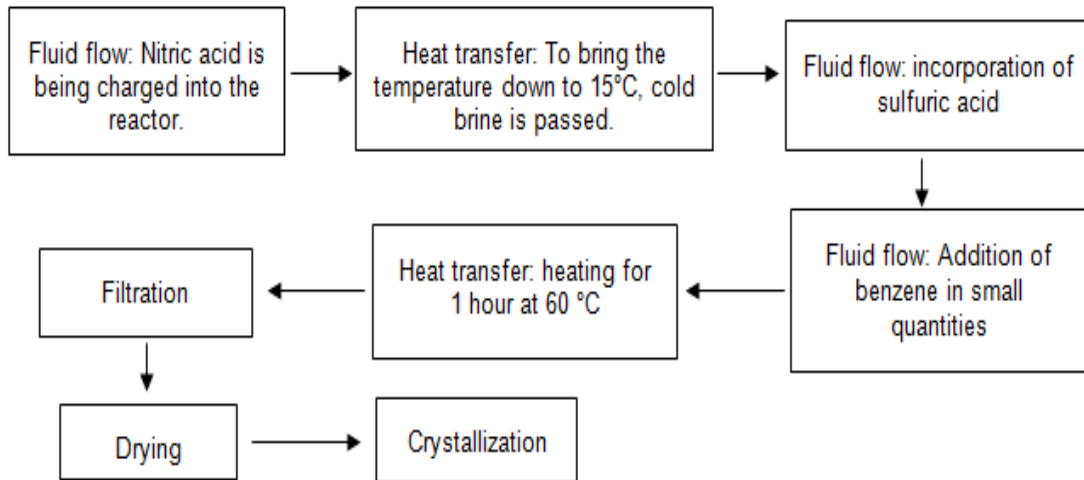

These examples show that unit operations are frequently employed to carry out the following physical steps:

- Reactant preparation
- Product separation and purification
- Reusing the original reactants
- Regulation of the chemical reactor's energy transfer into or out of the reactor

Thus, several steps are carried in a sequential order to achieve a process efficiently and economically. Here in this chapter, we will such in detail about two critical process namely, crystallization and lyophilization which is widely applicable in industrial processing of pharmaceuticals.

### III. CRYSTALLIZATION

1. **Crystals:** The solid particle known as a crystal is created during the solidification process and has its structural elements arranged in a rigid geometric pattern that is often referred to as a lattice. The liquid state is a typical source of crystal formation. For example, salt from a brine solution.
2. **Crystallization:** Crystallization is the process by which the particles spontaneously arrange themselves into a regular, ordered array or predictable geometric structure.

Through mass transfer, the chemical process of crystallization turns a solute from a liquid solution into a pure solid. The solvent evaporates when heated in an open container, leaving the solution fully saturated. The solution will separate from the solution and start to form crystals if the saturated solution is allowed to cool.

The following dose forms of medications are most frequently used in the solid state (powder forms):

Bulk powders intended for internal usage; examples include granules and fine powders.

- Large-scale powders for use on the body's surface, such as snuff, dusting powder, and toothpowder.
- Internal usage of powders, both simple and compound.
- Powders in the form of triturates and compressed tablets.
- Powders packaged in capsules and cachets.

#### IV. OBJECTIVES AND APPLICATIONS

Using medications in the solid state has a number of benefits.

- **Purification of Drugs:** A purifying technique is crystallization. The recrystallization procedure is used to clean medicinal goods of contaminants.
- **Better processing Characteristics:** To alter the micromeritics of pharmaceuticals, such as compressibility and wettability, crystallization process is applied.
- **Ease of Handling:** Crystallization makes a variety of tasks easier, including storage and transportation.
- **Greater Chemical Stability:** Drugs are more stable when they are crystallized. For instance, crystalline salt is more stable than amorphous penicillin G. Crystalline amitriptyline is more stable than amorphous amitriptyline.
- **Increased Physical Stability:** Crystalline forms are significant for product characteristics including tablet hardness and suspension stability. The stability of hygroscopic compounds can be improved by using dehydrating chemicals like dehydrated alcohol and glycerol.
- **Increased Bioavailability:** Some medications work better when they are crystallized. Penicillin G, for instance, does not dissolve right away in gastric juices. As a result, its disintegration slows down. Consequently, penicillin G's bioavailability increases.
- **Sustained Release:** Different-sized crystal drug ingredients can be employed to make sustained release dosage forms. For instance, protamine zinc insulin in crystalline form releases insulin from the injection site over an extended period of time slowly and continuously.
- **Miscellaneous:** Certain crystals are used in the production of semiconductor devices, laser beams and artificial gems.

#### V. THEORY OF CRYSTALLIZATION

Three steps are required for crystal formation from a solution.

- Supersaturation
- Nucleus formation
- Crystal growth

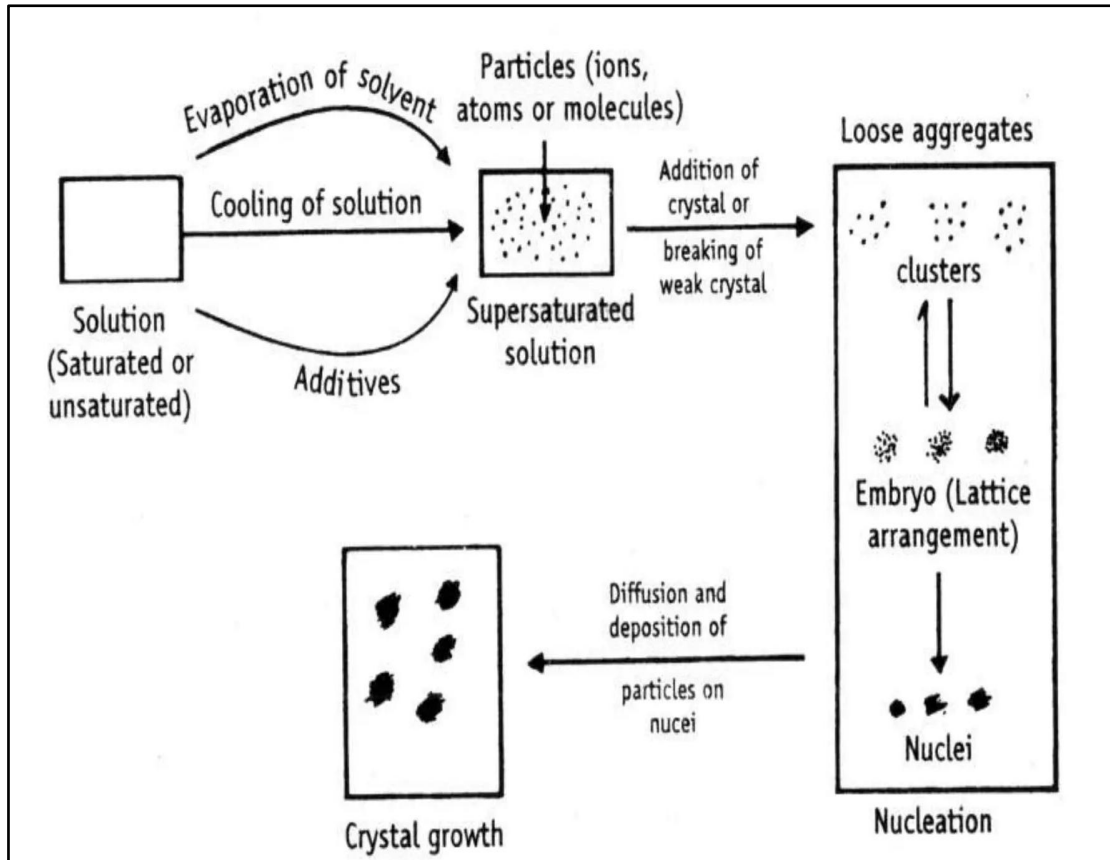

**Figure 1:** Mechanism of Crystallization

**1. Supersaturation:** When a material's solubility in a solvent is greater than its saturation solubility, the solution becomes supersaturated and the substance may precipitate or crystallize. Supersaturation is possible using:

- The solvent evaporates from the solution.
- If the solute has a positive heat of solution, cooling of the solution is the second step.
- A new solute gets formed as a result of a chemical reaction.
- Adding a material that is more solvent soluble than the solid that needs to crystallize.

Significant supersaturation is required to start the crystallization process through the production of nuclei in the absence of seed crystals. The nucleation and growth of nuclei are two sequential, mostly distinct processes that determine the rate of separation, particle size, homogeneity, and dispersion.

**2. Nucleation:** Clusters are first formed by the joining of many molecules, ions, or atoms. These are merely loose aggregates, and they frequently disappear quickly. However, when the numbers of particles assemble to form an embryo, the lattice structure begins to take shape and a new solid phase develops. Embryos frequently have a short lifespan and disintegrate soon after formation. An embryo could be in thermodynamic equilibrium with the solution when it reaches a particular size.

The first generated crystals, known as nuclei, are molecular in size. In rare circumstances, the nuclei develop in directions constrained by the amount of material present, resulting in the formation of crystals.

- 3. Crystal growth:** Crystallization is a process of diffusion and a surface phenomenon. Ions or molecules that are solutes travel from a solution to the faces of a crystal through a process called diffusion. When the molecules or ions reach the surface of the crystal, it must accept them and organize them into the space lattice. The rate at which this event takes place at the surface is finite; if the solution is not supersaturated, neither the interfacial step nor diffusion will occur.
- 4. Mier's Supersaturation Theory:** In an initially unseeded solution, crystals will spontaneously form at a specific temperature and concentration, according to Mier's theory of supersaturation. The supersolubility curve is said to reflect the upper limit at which spontaneous nucleus production occurs and, thus, the threshold at which crystallization can commence in the absence of any solid particle.

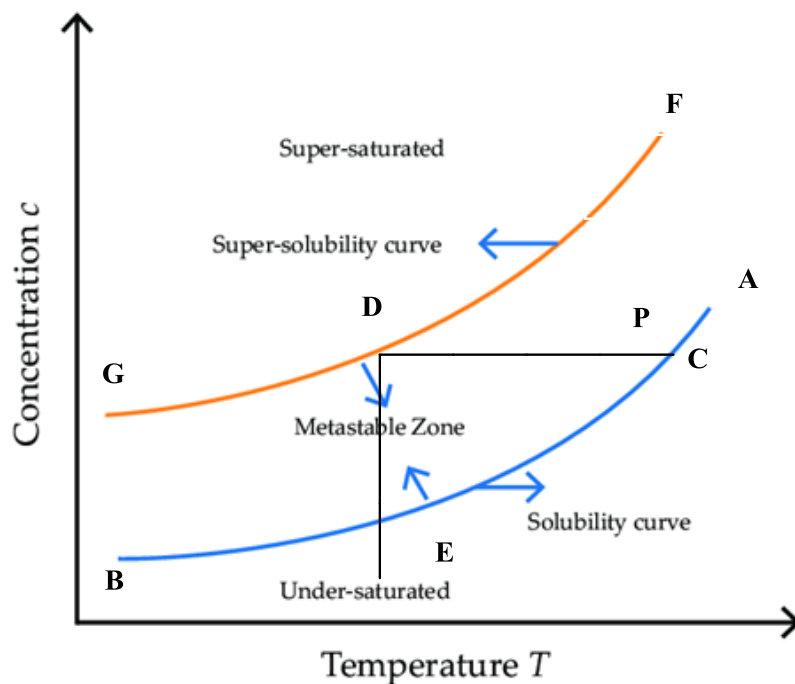

Figure 2: Mier's Supersaturation Theory

**5. Conditions for Obeying Mier's theory:**

- The solvent and the solute must be pure.
- There must be no solid solute particles in the solution.
- No foreign solid matter may be present in the solution.
- The solution needs to be sealed off from outside particles.
- During the procedure, weak or soft crystals must not form.
- The temperature should be maintained without any variations.

## 6. Limitations

- The crystallization start supersolubility curve, according to Mier's theory. However, crystallization typically occurs in an area rather than a line.
- Nucleation begins considerably below the supersolubility curve if the solution is held for longer periods of time.
- If a substantial volume of the solution is available, nucleation begins much below the supersolubility curve. This is because unintentional collisions between solute molecules are what lead to nuclei being formed. These collisions are more in large volumes than in small volumes.
- When using pure solute and pure solvent, Mier's hypothesis is appropriate. In reality, it is difficult to obtain them in their purest form.
- The solution needs to be kept in storage for prolonged periods of time to crystallize. Millions of dust particles may enter during storage. Dust particles can potentially start nucleation, in addition to solute molecules.

## VI. FACTORS AFFECTING CRYSTALLIZATION

Various factors affecting the crystallization process are,

- Presence of Another Substance
- Solvent Used
- Nucleation
- Crystal Growth
- Rate of Cooling

## VII. TYPES OF EQUIPMENT

### 1. Agitated Batch Crystallizer

- **Principle:** The temperature of a saturated solution is reduced in an agitated batch crystallizer to make it supersaturated. Crystal growth occurs in the supersaturated solution. When the solution is stirred, it is simpler to generate crystals of uniform size.
- **Construction:** It is made out of a cylinder with a conical bottom. The motor helps a propeller that is fixed in the centre to revolve on its own axis. Pipes constructed of heat-conducting material runs traverse from the crystallizer's right bottom to its left top.



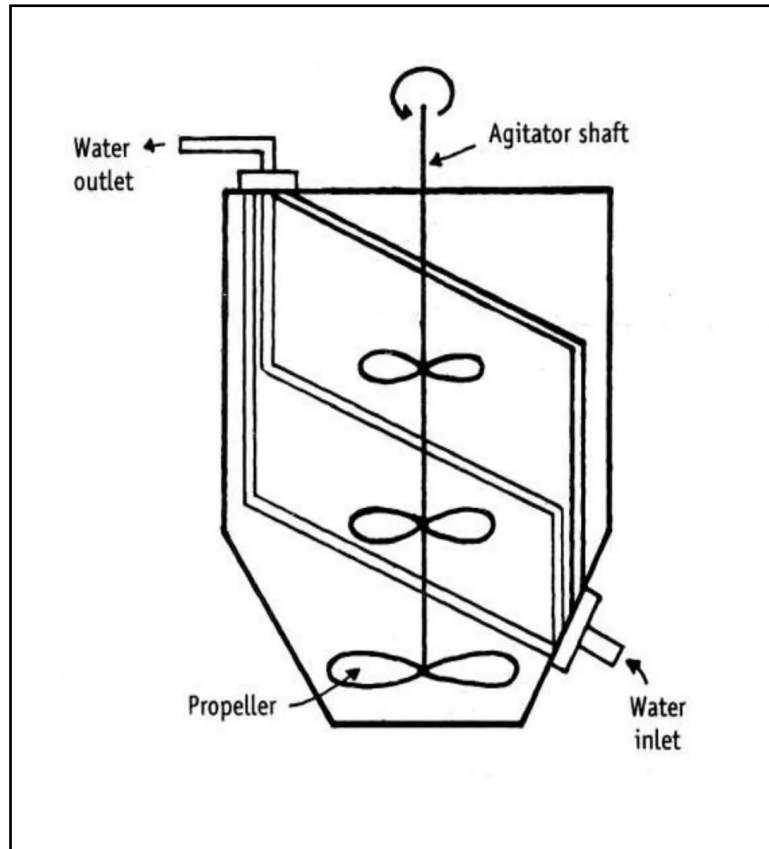

**Figure 3:** Construction of an agitated batch crystallizer

- **Working:** The crystallizer is filled with the solution that will undergo crystallization. Continuously, cold water is pumped via the pipes. When a solution cools, it supersaturates and crystals start to form. It serves two roles to let the propeller to revolve. Firstly, it speeds up heat transfer, which aids in keeping the solution's temperature nearly constant. Secondly, it helps fine crystals develop consistently by maintaining them in suspension. Otherwise, large crystals or aggregates may develop. By using an appropriate mechanism, the crystals are removed from the bottom for separation of mother liquor.
- **Advantages:** Compared to preceding crystallizers like the tank crystallizer, the crystals produced by an agitated crystallizer are more homogeneous and finer.
- **Disadvantages:** The equipment is batch or discontinuous. At the cooling coils' surface, solubility is lowest. Due to the rapid crystal formation at this stage, the coils quickly fill with a mass of crystals, slowing the rate of heat transfer.

## 2. Swenson Walker Crystallizer

- **Principle:** Cold water is pumped in the opposite direction of heated concentrated solution to cause crystallization. Super saturation consequently takes place, and crystals are subsequently deposited. Agitation prevents crystals from forming on the

cooling surface. It can be used as a continuous process because the crystals and mother liquor are separated simultaneously.

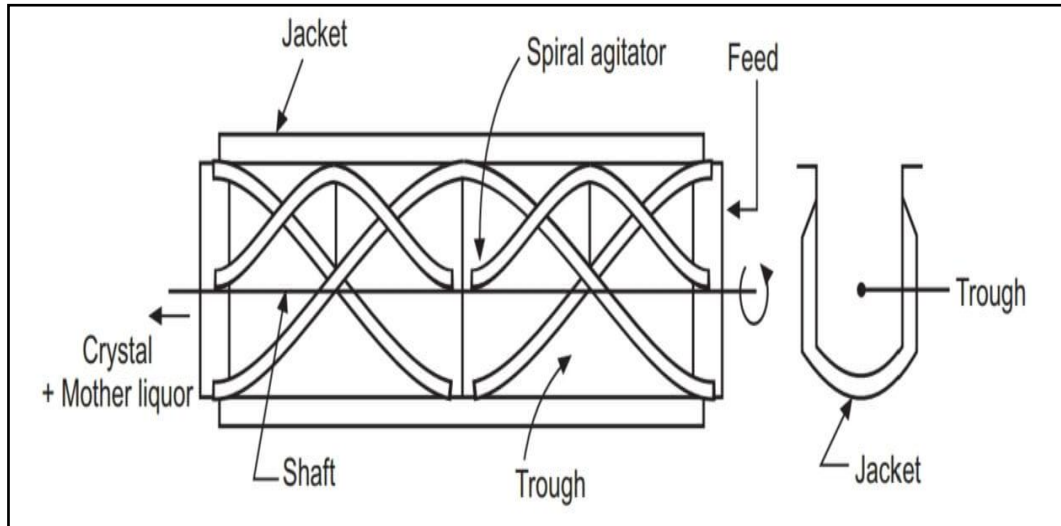

**Figure 4:** Construction of a Swenson Walker crystallizer

- **Construction:** It has a long, open trough that is about 0.6 metres wide and 3 metres long with a semi-cylindrical bottom and is of the linear kind. The waterjacket is externally welded to the trough. The bottom of the trough has a long pitch spiral scrapper fastened as closely as possible. The spiral scrapper is assisted in rotating on its own axis by the motor. For improved performance, a maximum of four of these units are connected. The capacity can be increased even further by stacking numerous such sets on top of one another. The answer in this configuration moves from one set to the one below it.
- **Working:** The left side of the trough is supplied with the hot, concentrated solution that is needed to crystallize. Cooling water enters the jacket on the right side. As the heated solution cools, super saturation is reached and crystal formation starts. By injecting more cooling water into the chosen areas, one may, if required, adjust the size of the crystals. The spiral scrapper revolves at an average speed of 7 revolutions per minute around its own axis. It aids in stirring the substance and moving the crystals. Additionally, by elevating the crystals, it avoids their buildup on the cooling surfaces. This produces a suspension that enables the crystals to develop independently. Therefore, aggregation is avoided.

The end of the crystallizer is attached to a draining table. Both the crystals and the mother liquor overflow into the draining table at the same time, with the crystals being kept and the mother liquor being sent back to the crystallizer. The centrifuge receives the wet crystals.

A screw conveyor can be used in place of the draining table. A screw conveyor with a little slope removes the crystals from the solution, and it then transports them to a centrifuge. The mother liquor spills over at a convenient location.

- **Advantages**

- The Swenson Walker crystallizer allows for significant space, material, and personnel cost savings.
- The procedure is continuous.
- It is possible to obtain crystals that are homogeneous in size and devoid of inclusions or aggregations.

- **Disadvantage:** While stirring the suspension, the scrapper may slightly break certain crystals.

### 3. Krystal Crystallizer

- **Principle:** In a crystallizer, the liquid is concentrated and crystallized in separate chambers called the vapour head and crystallizing chamber. A vacuum pump is used to accelerate the evaporation of a heated solvent, which results in the concentration of liquid (super saturation). The supersaturated solution and crystals are kept fluidized in the crystallization chamber to ensure uniform crystal formation. The fine crystals and supersaturated solution are circulated for further crystallization as the crystals of the required size sink down by gravity. The crystal growth chamber is used to harvest crystals that are of the required size.
- **Construction:** It consists of a vapour head and crystallizing chamber. Vapour head consists of a long tube, which extends almost to the bottom of crystallizing chamber. Other end of vapour head is connected to condenser and vacuum pump. A pump is provided which allows the feed to enter vapour head on its way to vapour head a heater is provided.
- **Working:** Pumped solution travels through the heater. Due to the decreased pressure, the hot solution flashes as it reaches the vapour head, causing solvent vapour and supersaturated solution to develop. The suction pump is used to remove the vapour. The process is managed such that crystals should form in the crystallizing chamber rather than the vapour head when the supersaturated solution flows through the long tube below.

A bed of crystals floating in an upward-moving stream of liquid makes up the crystallising chamber. The supersaturated liquid flows through the bed of crystals, which are kept fluidized. Thus, a consistent temperature is achieved. There is a continuous gradation of crystals in the chamber. Fine crystals remain above the coarser ones whereas coarse crystals settle towards the bottom. Occasionally, coarse crystals are removed via the hole at the bottom of the chamber as very fine crystals overflow through the liquid and into the recirculating system where they mix with fresh feed.

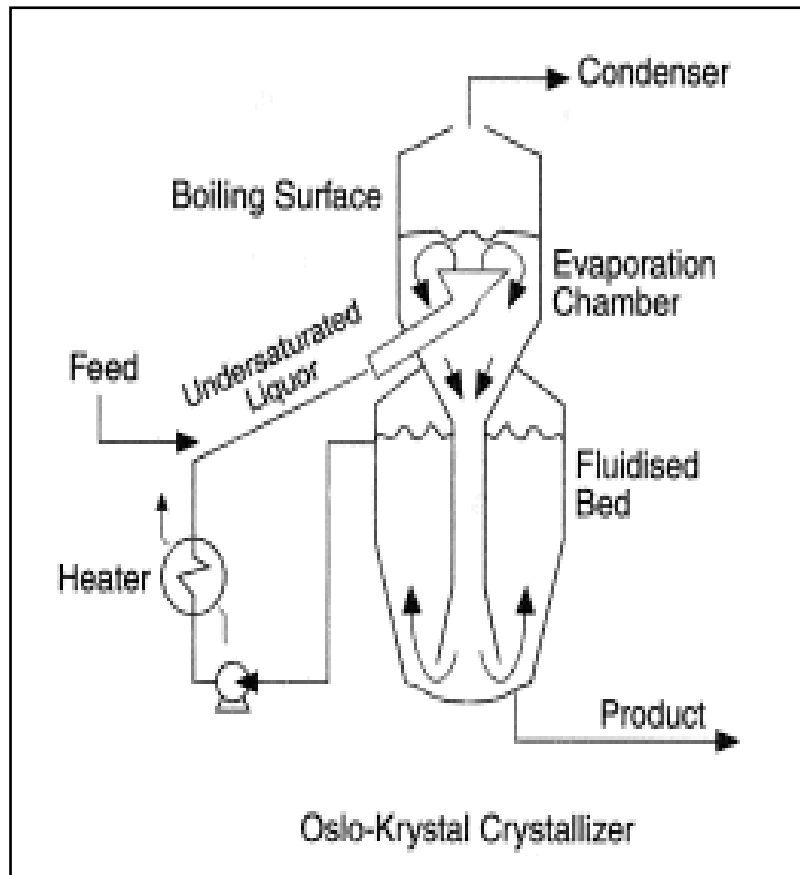
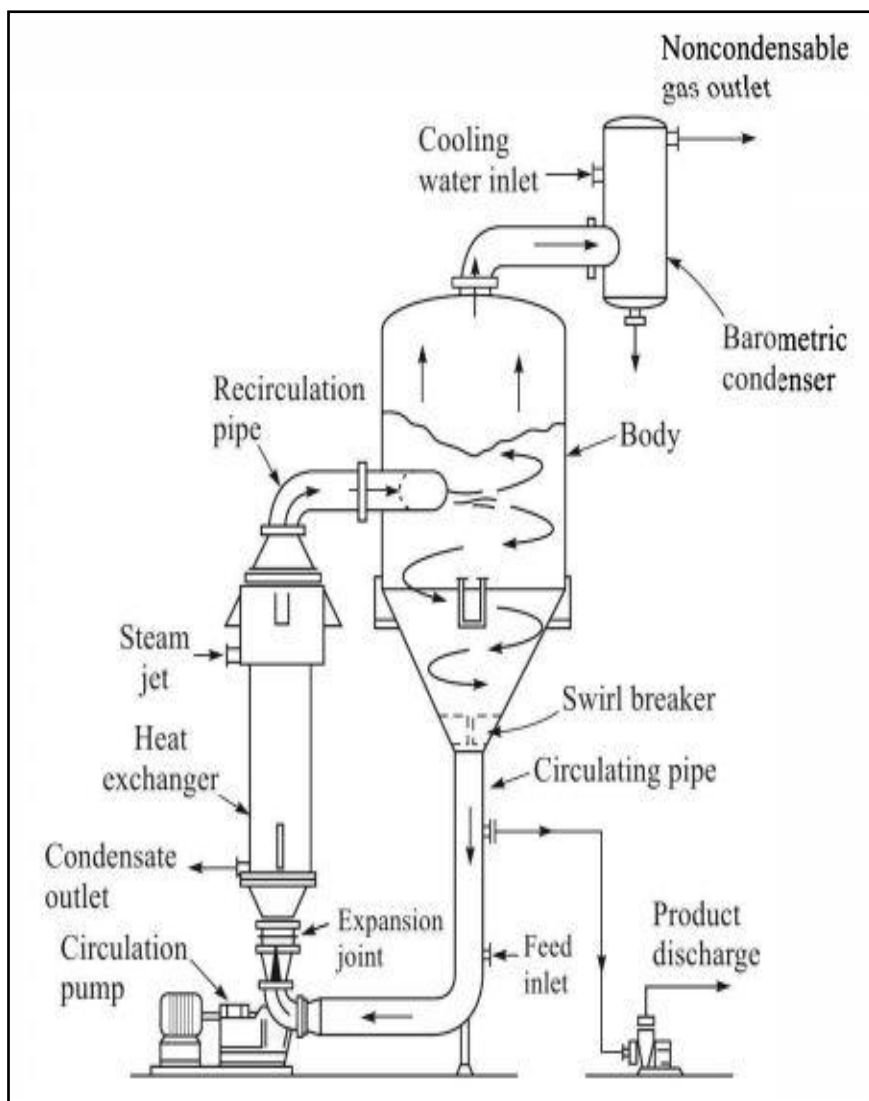

**Figure 5:** Construction of a Krystal crystallizer

- **Uses:** Magnesium sulphate and sodium chloride are crystallized using crystallizers.
- **Advantages**
  - Krystal crystallizers are preferred when large amounts of controlled-size crystals are needed.
  - The body of this crystallizer can be up to 4.5 meters in diameter and 6.0 meters in height.

#### 4. Vacuum Crystallizer

- **Principle:** Adiabatic evaporative cooling is used to achieve supersaturation in vacuum crystallizers. Due to the high vacuum in the crystallizer, heated saturated solution flashes when it is added. As a portion of the solvent evaporates, the solution cools and crystals get formed as a result of supersaturation.
- **Construction:** The cylindrical body of a vacuum crystallizer has a conical bottom. Internally, the crystallizer's body can be covered with an acid-resistant substance like lead or rubber. The bottom of the crystallizer is connected to a discharge pipe, and a condenser is attached to it through a vacuum pump. Two propellers are placed above the pipe to prevent a short circuit of the feed (to the discharge pipe).



**Figure 6:** Construction of a Vacuum Crystallizer

- **Working:** A vacuum pump is used to produce a high vacuum. The vacuum that results from this must be lower than the feed temperature and correspond to the solution's boiling point. Hot saturated solution is supplied into the crystallizer at an appropriate position, when it flashes and the solvent evaporates. The crystallizer body undergoes cooling as a result of the adiabatic nature of this operation. Crystallization and supersaturation are the results of the subsequent cooling. The yield is improved by the solvent evaporation. When the crystallizer flashes the solution, it causes ebullition, which keeps the crystals suspended until they are big enough to fall down the discharge pipe. The contents are fully mixed by the propellers, which also stop the contents from flashing as they reach the discharge pipe.
- **Uses:** Vacuum crystallizer is suitable for thermolabile substances, due to low temperature conditions

- **Advantages**

- The vacuum crystallizer has no moving parts and is very simple.
- Corrosive materials can be employed to create acid-resistant interior surfaces.
- It can be built in any size that is required.
- It can be used constantly or in batches.

## VIII. CAKING OF CRYSTALS

Caking can be defined as the process of formation of clumps or cakes when crystals are improperly stored.

Crystals must be preserved in bulk once they have crystallized in order to be used later, transported, or utilized to formulate dosage forms. The crystals must maintain acceptable flow characteristics while being stored, for instance, being able to readily move from the hopper to the die in the case of tablet punching. Crystals may have a tendency to form a cake while in storage. This problem becomes more serious in the case of small packages than in bulk packages. In certain situations, the crystals can be easily broken by the simple pressure of a thumb.

The critical humidity is the range of humidity in which crystals both absorb and do not absorb moisture.

A crystal remains dry when it comes into touch with air that has a humidity level below the critical humidity. On the other hand, the crystal collects moisture if the air is moister than the critical humidity level.

- **Factors Affecting Caking**

- Size of the crystals
- Shape of the crystals
- Humidity
- Time of exposure to humidity
- Impurities in crystals
- Melting point of crystals
- Temperature fluctuations

- **Prevention of Caking**

- Crystals should have fewer points of contact and a more spherical form.
- Crystals must have a tight size distribution, be greater in size, and include more voids. Highest possible critical humidity is required for crystals.
- To stop moisture from absorbing into crystals, they must be coated with a powdered inert substance. For instance, tricalcium phosphate or magnesia are added to table salt to coat it. Anhydrous calcium chloride is used to coat calcium chloride flakes.

## IX. LYOPHILIZATION

Lyophilization, also known as freeze drying, is the process of removing bound water molecules as well as ice or other frozen solvents from a material through the processes of desorption and sublimation. A freeze dryer, also known as a lyophilizer, is a piece of equipment used to dry solutions or suspensions at or below the freezing points of liquids.

- 1. Principle of Freeze Dryer:** Sublimation, in which water moves directly from the solid state (ice) to the vapour state without first passing through the liquid state, is the underlying mechanism of freeze-drying. Low pressures are necessary for sublimation to occur, which is a phase shift that requires the addition of thermal energy to the frozen product, as seen below on the water phase diagram.

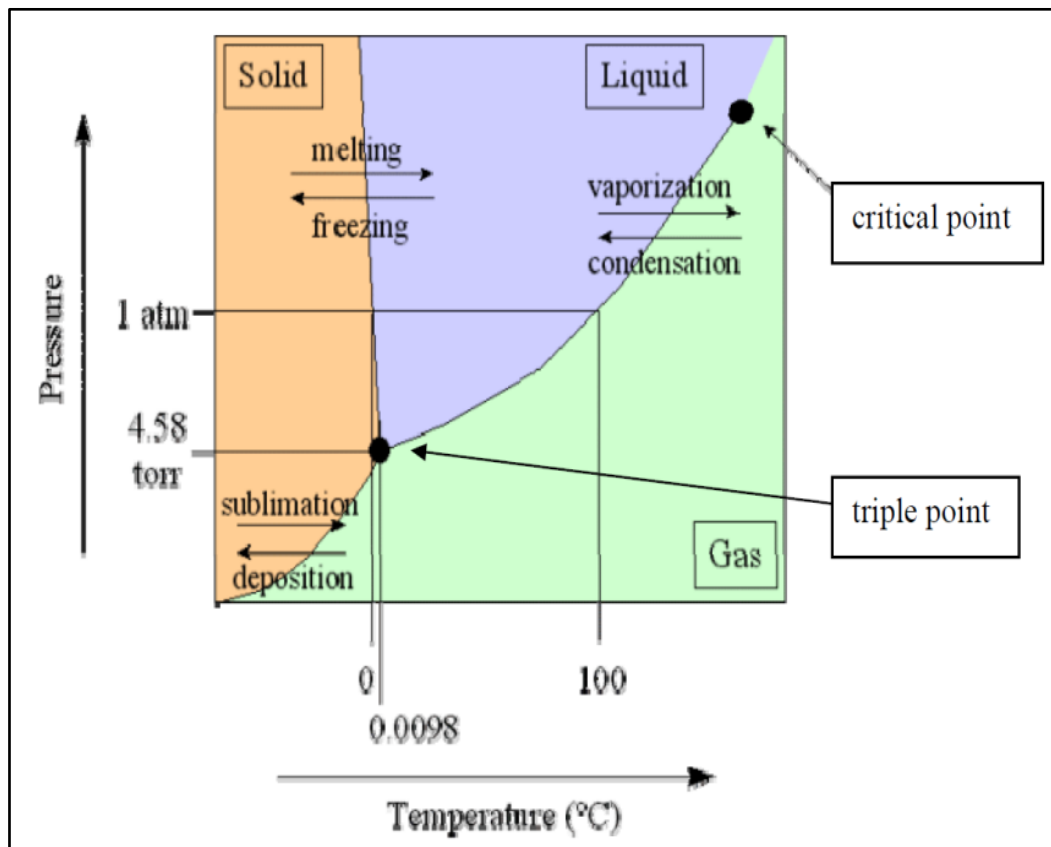

**Figure 7:** Phase diagram of water

Water can sublimate below the triple point, which is the point at which a substance may exist in equilibrium in the liquid, solid, and gaseous states. The triple point of pure water is reached at 0.01°C and 4.58 mm Hg. Any heat transmitted under these conditions is converted to latent heat, which causes ice to rapidly melt and transform into vapour. The water vapour is eliminated from the system by condensation in a cold trap maintained at a temperature lower than the frozen solid.

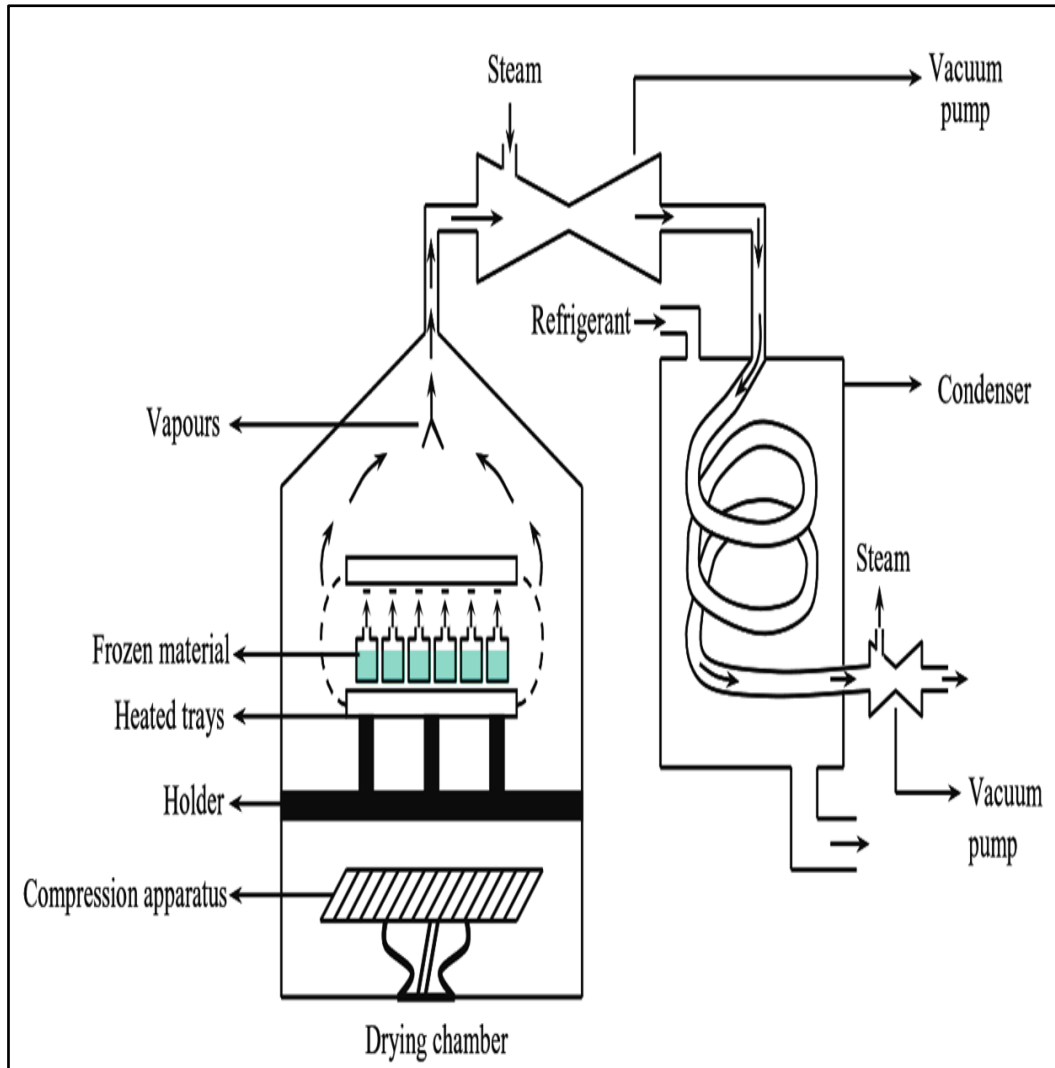

**Figure 8:** Diagram of Freeze Dryer

- 2. Construction of Freeze Dryer:** Freeze dryers come in three basic types, such as the manifold freeze-dryer, rotary freeze-dryer, and tray-style freeze-dryer. The process by which the dried item is connected to a condenser differs among these freeze-dryers.

The parts that are shared by all of them are a vacuum pump to lower the gas pressure in the surrounding area and a condenser to remove moisture by condensation on a surface chilled to between  $-20$  and  $-80$  °C.

- **Drying Chamber:** This stainless steel structure has a flat bottom and a conical top. With the aid of a holder, thermally heated trays are mounted horizontally in the middle. The compression device is positioned at the bottom (to carry out the compression mechanism). To allow for access and material removal from the chamber, a door is added. A hole located at the conical top of the chamber is used to attach a vacuum pipe to it.



- **Vacuum Pump:** It has an inlet for the steam jet and is situated between the drying chamber and the condenser.
- **Condenser:** To keep a temperature lower than the frozen material, it is made internally of a coiled pipe surrounded by a mixture of acetone and dry ice (solid CO<sub>2</sub>). The vacuum pump connects the condenser's two ends. The distance between the drying chamber and the condenser needs to match the mean free path taken by the molecules of the vapour. This quickens the drying process.



**Figure 9:** Freeze dried products

## X. IMPORTANT FREEZE DRYING TERMS

1. **Critical Temperature:** The highest temperature at which a product can be freeze dried without losing quality through melt-back or collapse. Determine this critical temperature of the product using thermal analysis (Differential Scanning Calorimetry & Freeze Dry Microscopy) and dielectric resistance analysis, which are both frequently used techniques.
2. **Collapse Temperature (T<sub>c</sub>):** This is the temperature at which a substance softens to the point where it is unable to support the structure that it already possesses. For a variety of reasons, this may be a problem:
  - Loss of physical structure
  - Incomplete drying
  - Decreased solubility
  - Lots of ablation (splat)
3. **Eutectic Temperature (T<sub>eu</sub>):** The solute substance melts at the eutectic temperature (T<sub>eu</sub>), which prevents any structure from developing after the solvent has been eliminated.

4. **Glass transition (T<sub>g</sub>'):** When a frozen substance reaches a certain temperature, it transforms from a brittle to a flexible structure.
5. **Annealing:** After being initially frozen, some amorphous products (such as mannitol or glycine) develop a metastable glass with imperfect crystallization. Thermal processing, commonly known as annealing, is a method that can help these items. To achieve more thorough crystallization, the product temperature is cycled during annealing (for instance, from -40°C to -20°C for a few hours, and then back to -40°C). The additional benefit of annealing is the bigger crystal formation and hence faster drying periods.
6. **Crystalline:** The substance possesses one or more eutectic points and crystallizes when frozen. Small crystals produced by rapid freezing are challenging to dry; annealing can aid in the formation of larger crystals.
7. **Amorphous:** Compositions with several components that lack a eutectic point and crystallize. They change into "glasses." It is necessary to do freeze drying below the glass transition temperature.

Glass structures found in frozen goods can be classified as either crystalline or amorphous. The "eutectic" freezing/melting point of crystalline goods, which is also its collapse temperature, is clearly characterized. Products that are amorphous have a higher "glass transition" temperature and are significantly harder to freeze dry. Amorphous materials' collapse temperatures are typically a few degrees higher than their glass transition temperatures. The term "eutectic" is frequently (and incorrectly) used to describe the freezing/melting point of any product, despite the fact that the majority of materials that are freeze dried are actually amorphous.



**Figure 10:** Collapsed Product – Critical Temperature was exceeded

## XI. STEPS INVOLVED IN LYOPHILIZATION PROCESS

The steps required to lyophilize a product in a batch process can be summarized as follows:

- Pretreatment and formulation,
- Freezing (thermal treatment),
- Primary drying (sublimation),
- Secondary drying (desorption)
- Backfill and Stoppering (for product in vials under partial vacuum)
- Freeze-dried Product Removal and Reconstitution

**1. Pretreatment:** Any form of product preparation prior to freezing is included. Pretreatment techniques include concentration by freezing, concentration in solution-phase, formulation to maintain product appearance, formulation to stabilize reactive goods, formulation to improve surface area, and reduction of high vapour pressure solvent. The choice to pre-treat a product is frequently based on theoretical understanding of freeze drying and its needs, which are influenced by cycle time or product quality considerations.

**2. Freezing:** The process of freezing, also known as pre-freezing, occurs when a sample is frozen to a lower temperature than its "eutectic point" or safe freezing point. This is normally between -40 and -60°C, while some applications may require temperatures as low as -60 to -80°C. The freeze dryer behaves like a freezer during pre-freezing because no Hoover is used. Pre-freezing might be carried out separately from the dryer.

Thermal analysis can be used to better understand a product's qualities in order to freeze it properly. There are various techniques for performing thermal analysis to find the eutectic point, but none of them are completely reliable.

- Time Versus Temperature Curve
- Differential Scanning Calorimetry
- Cryo Microscopy

Below are some collapse temperatures of typically freeze-dried products and solutions:

- Dextran (-9°C)
- Lactose (-32°C)
- Maltose (-32°C)
- Sorbitol (-45°C)

The ideal rate of freezing must be established when the product's freezing point (eutectic point) has been established. The size of the crystals is determined by the freezing rate. It is crucial to remember that when the frozen liquid eventually sublimates out of the product, the larger crystalline structure created by a slow freeze rate will result in a more porous and quickly dried product. However, it may not result in the best

product in terms of reconstitution (rehydration), even if this is normally good for optimizing freeze drying cycles.

On the other hand, even though it takes longer to freeze dry, a substance that freezes quickly would deactivate more quickly, have a smaller crystalline structure, and be more granulated, making it simpler to reconstitute. A general rule of thumb is that the product container should never be filled to more than half of its total content when freezing items in vials. Some biological products must be freeze dried with lower ice crystal sizes because they cannot tolerate huge ice crystals.

- 3. Primary Drying:** The ice sublimates (converts quickly into vapour) during the primary drying phase, which can last as short as 0.01 hPa (mBar) or less depending on the sample's pre-freezing temperature. The average range of pressure for freeze drying is 50 to 300 Torr, with 100 to 200 Torr being the most widely used range. The pressure differential between the product ice surface and the condenser ice surface, together with the accompanying temperature difference, is what drives sublimation. When freeze drying a product, all three types of heat transfer—conduction, convection, and radiation must be taken into account.

Larger temperature variations also result in larger pressure differences, which speed up the process. The removal of air molecules by the vacuum quickens the process by facilitating easier passage of sample vapour molecules from the sample through the chamber and into the condenser. During primary drying, the shelf temperatures typically ramp up from  $-40$  to  $+20^{\circ}\text{C}$  throughout the course of the operation, It can endure for a short period of time or several days. Through heat conduction (contact to the shelf) and heat radiation from the shelf above, the shelf temperatures have an indirect impact on the sample's ice temperature. Very little heating occurs through convection in the chamber since there are so few air molecules there. Small sensors placed within the vials measures the sample temperature(s) and record changes.

The condenser's temperature needs to be lower than the product's temperature for a freeze dryer to work properly. The net migration of water vapour towards the condenser is caused by the pressure differential caused by this temperature difference.

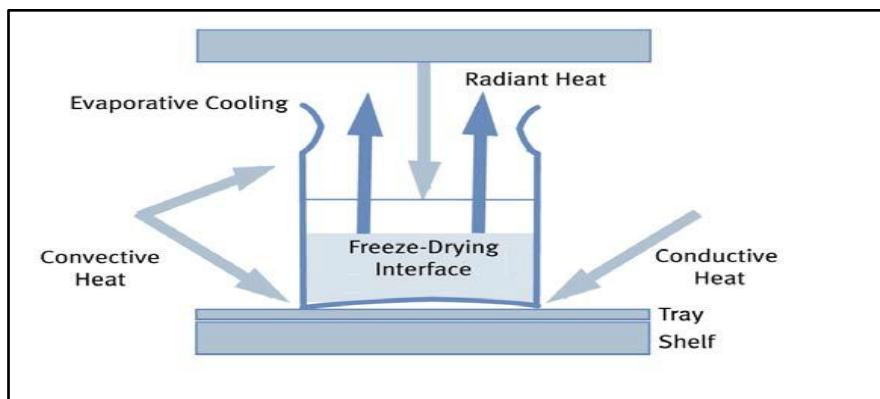

**Figure 11:** Heat Transfer in a Shelf Freeze Dryer

- 4. Determination of the End of Primary Drying:** Analytical evaluation of the state of primary drying is possible utilising a number of methods. The most basic method is to use a thermocouple probe to monitor the product temperature. The recorded product temperature will be lower than the shelf temperature set point during active primary drying, when the heat from the shelf is being used for the sublimation phase transition. After the ice crystal sublimation process is complete, the product temperature will rise and get very close to the shelf temperature. When the product temperature exceeds shelf temperature, the primary drying process is considered to be complete.

One such method involves comparing parallel pressure readings obtained from a Pirani gauge with a capacitance manometer. A capacitance manometer always gives a precise reading of the pressure in the product chamber. However, the Pirani gauge will show an erroneously high value if there is water vapour present. When the Pirani pressure measurement drops and becomes close to the capacitance manometer's actual pressure reading, it may be considered that primary drying is complete. At that time, little to no water vapour is present.

With freeze dryer designs that include exterior condensers, another tool is offered. The vapour port that joins the product chamber to the condenser can receive an isolation valve. The rise in pressure that occurs when this valve is closed for a brief period of time can be observed. Sublimation stops producing water vapour when this pressure rise reaches zero.

- 5. Secondary Drying:** A significant amount of water molecules that are attached to the product still remain in addition to the free ice that is sublimed during primary drying. During secondary drying, this is the water that is eliminated (desorbed). The primary drying process eliminated all free ice, allowing for a significant increase in product temperature without bothering about melting or collapsing.

Although desorption occurs at higher temperatures (usually between 30°C and 50°C), secondary drying really begins during the primary phase. The product temperature affects the secondary drying rates. Lower vacuum levels won't speed up secondary drying; system vacuum can be maintained at the same level as during primary drying.

In order to prevent collapse, it may be necessary to manage the temperature increase from primary to secondary drying at a slow ramp rate.

- 6. Stoppering and Storage of Dried Product:** In order to prevent rehydration due to atmospheric exposure, lyophilized products must be kept in airtight containers after being freeze dried. It is wise to stopper samples inside the freeze-dryer prior to removal because water and air both harm dried samples, creating degradative changes that lead to poor stability.

Freeze dryers may be designed with a "stoppering" feature that allows the product to be sealed inside the appliance while it is still partially vacuumed. Usually, vials with partially placed stoppers need to be stopped. When the shelves are crushed, the vials or stoppers on the neighbouring shelf are pushed down by each shelf. Before sealing or stopping the product, it is also usual to backfill with an inert gas, such as dry nitrogen.

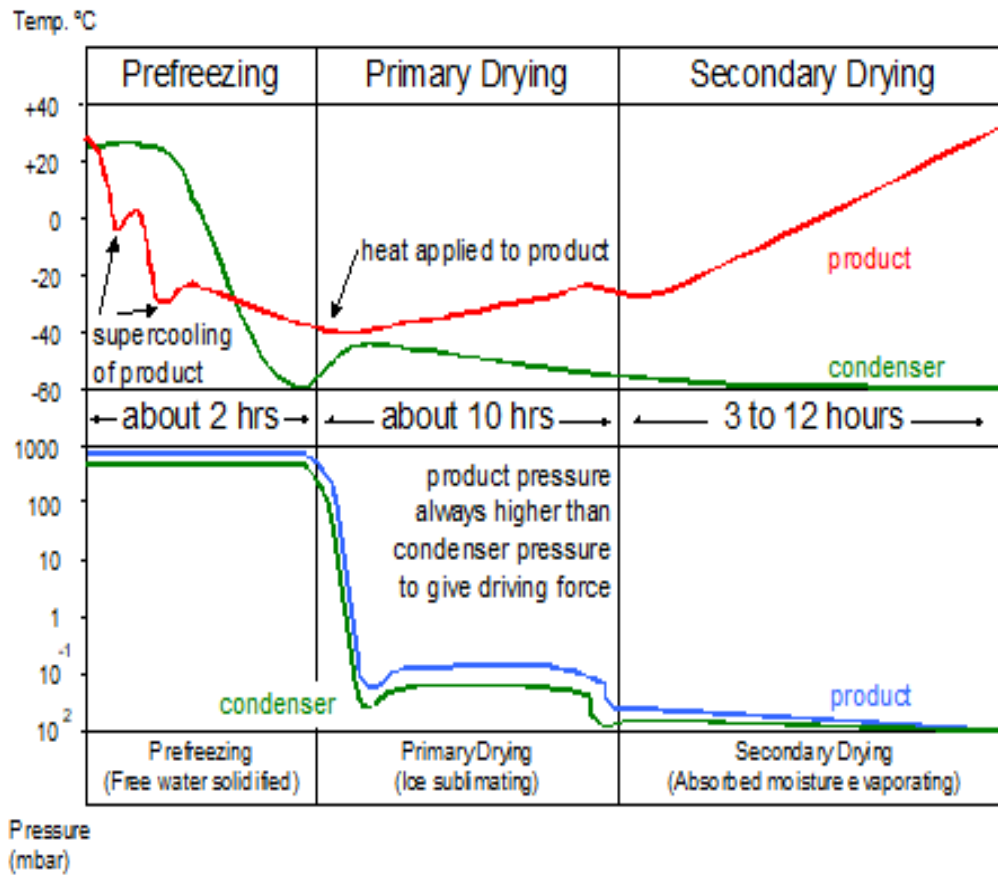

**Figure 12:** Overview of Lyophilization process

**7. Reconstituting the Product:** It's frequently assumed that since freeze-drying merely removes water, rehydrating all products with water will restore their full functionality. This might not be the case since freeze-dried goods frequently show increased activity when reconstituted in an isotonic solution, like saltwater, as instead of water.

## XII. PROBLEMS TO AVOID DURING FREEZE DRYING

- Melting back or product collapse might result from overheating the product.
- Overloading of the condenser brought on by too much vapour entering it.
  - Too much vapor creation
  - Too much surface area
  - Too small a condenser area
  - Insufficient refrigeration
- Vapour choking: When vapour is produced at a pace that exceeds its ability to pass through the vapour port, which is the port that connects the product chamber and the condenser, the chamber pressure rises.

### **XIII. ADVANTAGES OF FREEZE DRYER**

- Thermolabile (heat-sensitive) items can be dried with this.
- Freeze-dried goods are porous and quickly dissolve when rehydrated.
- Drying occurs at extremely low temperatures to prevent enzyme activity and reduce chemical degradation, particularly hydrolysis.
- Protein denaturation does not take place.
- Less volatile material loss occurs.
- Sterility may be preserved.
- Moisture level can be kept as low as possible without decomposition.
- The final product can be stored at ambient temperature if well sealed by providing inert atmosphere.

### **XIV. DISADVANTAGES OF FREEZE DRYER**

- The method is really slow.
- Expensive method.
- The drying time is lengthy.
- Because of the product's high porosity and wide surface area, it must be packed with a vacuum or an inert gas to prevent oxidation.

### **XV. APPLICATIONS OF FREEZE DRYER**

- Thermolabile items, such as vaccines, blood plasma and products, bacterial and viral cultures, human tissues, antibiotics, steroids, vitamins, and other injectables, are freeze-dried to extend their shelf life.
- It helps make things more stable throughout storage, shipping, and transportation.
- Freeze-drying is a technique used to lighten materials.
- It is used to preserve freeze-dried blood products.
- It is applied in chemical synthesis to create more stable and water-soluble compounds.
- Bio-separations and purification procedures can be successfully carried out via freeze-drying.
- Low molecular weight compounds that can't be eliminated by membrane filtration can be concentrated using this method.

### **REFERENCES**

- [1] A Textbook of Pharmaceutics by Dr. Ashok Hajare, Nirali Prakashan
- [2] Elements of Pharmaceutics by Shalini Sharma, Pee Vee Publications (PV Books)
- [3] Beckmann, W. 2013. Crystallization: Basic Concepts and Industrial Applications, Wiley.
- [4] Pharmaceutical Engineering (Principles and Practices), C.V.S. Subramaniam, J.ThimmaSetty, Sarasija Suresh, V.Kusum Devi, VallabhPrakashan
- [5] Davey, R. and Garside, J. 2000. From Molecules to Crystallizers, Oxford University Press.
- [6] Concise Course in Pharmaceutics by Md. Sadat Khan and C.B. Hangargekar, Dr.Kuchake & S.D. Tayade, Pee Vee Publications (PV Books)
- [7] Basics Principles of Freeze drying, John Barley, SP Scientific, Available at <https://cdn.scientificproducts.com/media/W1siZiIsIjIwMjIvMDUvMTEvMDgvNDkvNDgvZTU1NTIyZTctMzlkOC00NjI3LTlmYzktY2VINGM3YjMxZWNIL1NQIC0gVGVjaCBOb3RlIC0gQmFzaWMgUHJpb>

mNpcGxlcYBvZiBGcmVlemUtRHJ5aW5nLnBkZiJdXQ/SP%20-%20Tech%20Note%20-%20Basic%20Principles%20of%20Freeze-Drying.pdf?sha=1a38f90643e76aa0

- [8] The Freeze Drying Theory and Process Things to Consider, Ellab-whitepaper, 08/18. Available at file:///C:/Users/marak100/OneDrive%20-%20Otis%20Elevator/Documents/the-freeze-drying-theory-and-process\_ellab-whitepaper.pdf
- [9] FreezeDryersfrom Laboratory to Production, Millirock Technology. Available at <https://www.millrocktech.com/lyosight/lyobrary/what-is-a-freeze-dryer/>