

ADVANCEMENT IN NANOTECHNOLOGY

Abstract

The advances in nanotechnology have brought new tools to the field of electronics and sensors. New designed materials offer new and unique properties enabling the development and cost efficient production of state-of-the-art components that operate faster, has higher sensitivity, consume less power, and can be packed at much higher densities. Numerous products based on nanotechnology have been reaching the market for some years, all the way to end users and consumers. For instance, at the nano-scale, the resistance dependence of a material on an external magnetic field is significantly amplified, which has led to the fabrication of hard disks with a data storage density in the gigabyte and terabyte ranges. Nanotechnology has also enabled the development of sensors suitable for measurements at the molecular level with an unprecedented sensitivity and response time, mainly due to their high surface to volume ratio.

Keywords: advances, nanotechnology, sensitivity, high surface

Authors

Ananya M V
Department of ECE
MVJ College of Engineering(A)
Bangalore, India.
ananyamv243@gmail.com

Donna Liz Vinoth
Department of ECE
MVJ College of Engineering(A)
Bangalore, India.
donnalizvino@gmail.com

Prakruthi N L
Department of ECE
MVJ College of Engineering(A)
Bangalore, India.
gprakruthinl444@gmail.com

Ruchitha G V
Department of ECE
MVJ College of Engineering(A)
Bangalore, India.
ruchitha162004@gmail.com

I. INTRODUCTION

Nanotechnology, often shortened to nanotech, is the use of matter on atomic, molecular, and supramolecular scales for industrial purposes. The earliest, widespread description of nanotechnology referred to the particular technological goal of precisely manipulating atoms and molecules for fabrication of macroscale products, also now referred to as molecular nanotechnology. A more generalized description of nanotechnology was subsequently established by the National Nanotechnology Initiative, which defined nanotechnology as the manipulation of matter with at least one dimension sized from 1 to 100 nanometers (nm). This definition reflects the fact that quantum mechanical effects are important at this quantum-realm scale, and so the definition shifted from a particular technological goal to a research category inclusive of all types of research and technologies that deal with the special properties of matter which occur below the given size threshold. It is therefore common to see the plural form "nanotechnologies" as well as "nanoscale technologies" to refer to the broad range of research and applications whose common trait is size.

Nanotechnology is the engineering of functional systems at the molecular scale. It includes current work and concepts that are highly advanced. It is the design, characterization, production, and application of structures, devices, and systems by controlled manipulation of size and shape that produces structures, devices, and systems with superior characteristics or properties.

Nanotechnology, the science of manipulating matter at the nanoscale, has emerged as a groundbreaking field that captivates scientists, engineers, and innovators worldwide. At its core, nanotechnology involves harnessing the unique properties and behaviors of materials at the atomic and molecular level, bringing about a profound impact on diverse industries and paving the way for a more technologically advanced and sustainable future.

The term "nano" originates from the Greek word "nanos," meaning dwarf. In the context of nanotechnology, it denotes one billionth of a meter, making it a realm where matter is measured at the scale of 1 to 100 nanometers. It is within this minuscule domain that materials display novel characteristics, different from those found in their bulk form, opening the door to revolutionary applications.

II. HOW NANOTECHNOLOGY CAN BE USEFUL IN ELECTRONIC DEVICES?

Nanotechnology integrated into electronic devices offers a pathway to enhancing their functionalities. Furthermore, it contributes to the reduction of weight and power consumption. This technology plays a pivotal role in refining the display screens of electrical devices, entailing diminished power usage alongside reductions in screen weight and thickness. Notably, ongoing research focuses on amplifying memory chip density, with endeavors directed towards achieving a memory chip density of one terabyte per square inch or beyond. It has revolutionized the field of electronics, offering a multitude of ways to enhance the performance and functionality of electronic devices.

It enables the creation of nanoscale components and structures that are essential for miniaturization. By utilizing nanoscale materials, transistors, and other electronic components, devices can be made smaller, lighter, and more portable, leading to advancements in smartphones, laptops, wearables, and other electronic gadgets.

Nanomaterials, such as carbon nanotubes and graphene, exhibit exceptional electrical conductivity. These materials can be integrated into electronic devices, providing faster electron transport and reduced resistive losses, thereby enhancing the overall efficiency of the devices. It allows the design of nanoscale structures with unique properties, leading to improved performance of electronic devices. For example, quantum dots - nanoscale semiconductor crystals - are used in displays and LED lighting to produce vivid colors and better energy efficiency.

It enables the development of highly sensitive and selective nanosensors. These sensors can detect and respond to specific signals or changes in the environment, making them crucial for various applications, including environmental monitoring, healthcare, and security. It plays a significant role in improving energy storage devices like batteries and supercapacitors. Nanomaterials, such as nanowires and nanocomposites, offer higher surface area and faster charge-discharge rates, leading to better energy density and faster charging times for electronic devices.

Nanotechnology allows the creation of flexible and stretchable electronics using nanomaterials, such as conductive nanowires and nanocomposites. These materials can be integrated into wearable devices, bendable screens, and rollable electronics, expanding the possibilities for futuristic gadgets.

Nanotechnology provides innovative solutions for managing heat dissipation in electronic devices. Nanoscale materials with high thermal conductivity can be used as heat spreaders to prevent overheating and improve the reliability and lifespan of electronic components.

The integration of nanotechnology into electronic devices continues to drive innovation, enabling the development of smarter, more efficient, and versatile technologies. As nanotechnology advances, it holds the potential to reshape the landscape of electronics, pushing the boundaries of what is possible and shaping a more connected and technologically advanced future.

III. WHAT EXACTLY NANOTECHNOLOGY MEANS?

Nanotechnology constitutes a realm of exploration and innovation concentrated on crafting entities at the atomic and molecular magnitude. This arena encompasses the design of both materials and devices. A nanometer measures a mere billionth of a meter in length, equivalent to roughly ten times the diameter of a hydrogen atom. To put this scale into perspective, one nanometer is equal to one billionth of a meter. At such a small scale, materials can exhibit unique properties and behaviors that differ significantly from their bulk counterparts. Nanotechnology seeks to harness these distinctive characteristics to create new materials, devices, and systems with improved performance and functionalities.

Nanotechnology is lauded for its potential to elevate energy efficiency, address environmental challenges, and combat pressing health issues. Moreover, it holds the capacity to enhance manufacturing productivity while simultaneously reducing costs. Anticipated nanotechnology products are envisioned to be characterized by their compactness, affordability, and reduced weight. These advancements are poised to imbue these products with heightened utility, necessitating less energy and diminished raw materials for production. It encompasses various disciplines, including physics, chemistry, biology, materials science, and engineering. Researchers in these diverse fields collaborate to explore and exploit the unique phenomena and properties that arise at the nanoscale. As research continues and technology advances, nanotechnology holds the promise of revolutionizing various industries and improving the quality of life for people around the world.

Nanotechnology Products and Applications:

- Nanoelectronics
- Nanocoating
- Energy Nanomaterials (Solar panel)
- Aerospace Nanotechnology
- Display Nanotechnology
- Molecular Electronics
- Quantum Computing
- Single Electron Transistor
- Nanocomposites
- Nano sensors
- Carbon-Based Sensors
- Printed Electronics
- Transistors On the Nanoscale
- Smaller And Enhanced Handheld Devices
- Computational Nanotechnology

1. Use of Nanotechnology in Nanoelectronics:

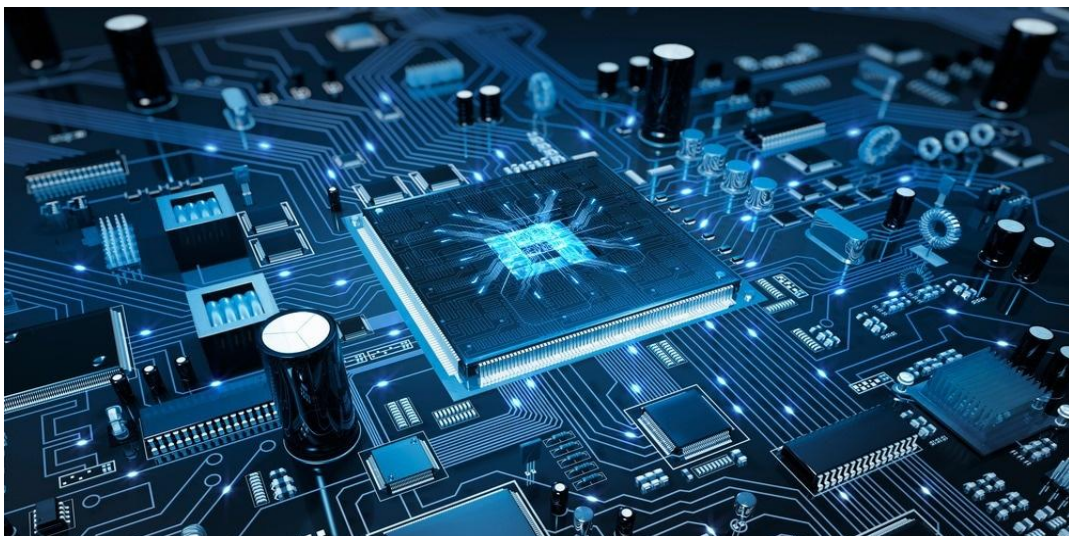

The application of nanotechnology in electronic components gives rise to nanoelectronics, where these constituents measure just a few nanometers. However, the pursuit of smaller electrical components introduces increased fabrication complexities. Nanotechnology's integration into electronic devices spans a diverse array of materials and devices, characterized by their minute scale, where physical phenomena begin to shape material properties at the nanoscale. The operation of these devices hinges on inter-atomic interactions and the intricacies of quantum mechanical properties. It is a specialized field of nanotechnology that focuses on creating electronic devices and components at the nanoscale. It aims to exploit the unique properties of nanomaterials to design and fabricate more efficient, smaller, and faster electronic devices than what is possible with conventional microelectronics. Nanoelectronics plays a pivotal role in advancing the capabilities of modern electronics and is essential for continued progress in areas such as computing, communication, and sensors.

- **Chip fabrication:** Extreme ultraviolet lithography will use mirrors to direct light with a wavelength of 13 nanometers to print features at 32-nanometer scale. The smaller scale will yield chips that run much faster.
- **Batteries:** Lithium ion batteries using multiwalled nanotubes are safer and more effective, with up to 10 times life and 5 times the available power are already available in the market.
- **DVDs:** Quantum dots-semiconductor crystals that are just a few nanometers wide-provide the needed precision for Blu-ray and HD DVD blue lasers.
- **Nanowires:** Semiconductor nanowires are one dimensional structures, with unique electrical and optical properties, that are used as building blocks in nanoscale devices. Stripped or 'superlatticed' nanowires can function as transistors, LEDs (light-emitting diodes) and other optoelectronic devices, biochemical sensors, heat-pumping thermoelectric devices, or all of the above, along with the same length of wire.

2. Key Concepts and Components:

- **Nanoscale Materials:** Nanoelectronics relies on nanomaterials, which can be either organic or inorganic in nature. Examples include carbon nanotubes, graphene, semiconductor nanowires, quantum dots, and nanocomposites. These materials exhibit extraordinary electrical, thermal, and mechanical properties due to their small size and unique quantum effects.
- **Quantum Effects:** At the nanoscale, quantum mechanical effects become more pronounced. Quantum confinement and tunneling phenomena can be harnessed to create devices with quantum computing capabilities and ultra-sensitive sensors.
- **Transistors:** Transistors are the fundamental building blocks of modern electronics. Nanoelectronics involves designing nanoscale transistors to replace or complement traditional silicon-based transistors. For instance, carbon nanotube transistors and graphene transistors are being explored for their potential in high-performance computing.

- **Nanowires and Nanotubes:** Nanowires and nanotubes serve as interconnects between different components in nanoelectronic circuits. These structures offer reduced resistance and improved electrical performance, which is crucial for next-generation electronic devices.
- **Quantum Dots:** Quantum dots are semiconductor nanoparticles that exhibit unique optoelectronic properties. They can emit light of specific colors based on their size, making them ideal for applications in displays, sensors, and lighting.

3. Applications of Nanoelectronics:

- **Computing:** Nanoelectronics enables the development of faster and more energy-efficient processors and memory devices. It facilitates advancements in quantum computing, where quantum bits (qubits) take advantage of quantum phenomena to process information exponentially faster than classical bits.
- **Sensors:** Nanoelectronic sensors have high sensitivity and selectivity, making them valuable in various applications, including environmental monitoring, healthcare diagnostics, and industrial process control.
- **Communication:** Nanoelectronics contributes to the development of high-frequency and high-speed communication devices, such as nanoscale transceivers for wireless communication systems and advanced signal processing devices.
- **Energy Storage and Conversion:** Nanotechnology-based electronic devices enhance energy storage solutions like batteries and capacitors. It also enables more efficient energy conversion through the development of novel solar cells and energy harvesting devices.
- **Medical Electronics:** Nanoelectronics plays a significant role in medical devices, such as implantable sensors, lab-on-a-chip technologies, and neuroprosthetics for restoring lost sensory functions.

4. Challenges and Future Directions:

Despite the promising potential of nanoelectronics, several challenges need to be addressed. Manufacturing and scalability are significant obstacles in the mass production of nanoelectronic devices. Additionally, issues related to reliability, stability, and compatibility with existing technologies require careful consideration.

As researchers continue to overcome these challenges, nanoelectronics is poised to drive innovation and revolutionize various industries. The continued exploration of nanomaterials and the realization of quantum computing could lead to transformative advancements that shape the future of electronics and computing.

5. Introduction of Nanocoating:

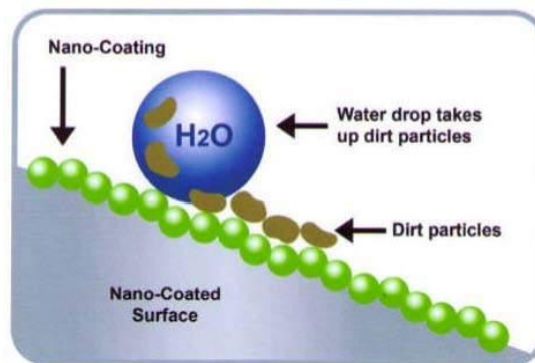

Nanocoatings encompass delicate layers deposited onto surfaces to engender or enhance diverse functionalities. These functionalities encompass safeguards against corrosion, fortifications against water, ice, and friction, and attributes like antifouling and antibacterial properties, including self-cleaning prowess. The application of nanocoatings contributes to amplified heat and radiation resilience, while also effectively managing thermal aspects. Notably, nanocoatings confer substantial advantages across sectors such as aerospace, defense, medical, marine, and oil industries. Manufacturers are strategically employing nanocoatings to establish their products as distinctive within the competitive landscape.

Coatings developed for anti-microbial properties generally contain silver nano-particles. Silver has natural anti-bacterial and anti-fungal properties and silver engineered into nano-particle size increases the surface area in contact with micro-organisms which, in turn, improves its bacterial and fungicidal effectiveness (Nanotech Plc 2006). Products using silver nano-particle coatings include:

- Daewoo refrigerator – using “Nano Silver Poly technology”, in which particles of silver are mixed in plastic resin. It is applied to major parts of the refrigerator in order to restrain the growth and increase of a wide variety of bacteria and to suppress odours (Daewoo 2006).
- Daewoo vacuum cleaner – the vacuum cleaner has a nanosilver-coated ‘cyclone canister’ that allegedly has the effect of removing bacteria and a plethora of dust particles, inhibiting odour, allergy-inducing spores, and other harmful debris (Daewoo 2006).
- Daewoo washing machine – again uses Nano Poly Technology by which, according to the manufacturer, “many hurtful bacteria in clothes shall be sterilized perfectly” (Daewoo 2006).
- Antibacterial mobile phones – LG Electronics use a Nano Silver antibacterial coating on their mobile phone (Woodrow Wilson International Centre for Scholars 2006). The Motorola i870 mobile phone has an anti-bacterial coating made from silver zeolite nanoparticles (Motorola 2005).

- Germ free wireless laser mouse by IOGEAR Inc. - coated with a titanium dioxide and silver nanoparticle compound (Woodrow Wilson International Centre for Scholars 2006). According to the manufacturer, “the special coating protects users from bacteria and germs by neutralizing the harmful microbes on the mouse”.

Besides using silver nanoparticles as coatings, Samsung have developed techniques for using them in the wash cycle – the so called ‘silver wash’ technology which is designed to improve the washing of clothes.

- **Key Features and Types of Nanocoatings:**

- **Size and Structure:** Nanocoatings are designed using nanomaterials with specific size, shape, and structure, which enable them to exhibit novel properties at the nanoscale. This includes a large surface-to-volume ratio, quantum effects, and surface functionalities.
- **Functionality:** Nanocoatings can offer a wide range of functionalities, such as anti-corrosion, anti-scratch, self-cleaning, anti-fouling, anti-microbial, anti-reflective, and hydrophobic or hydrophilic surfaces.
- **Materials:** Nanocoatings can be made from various nanomaterials, including metal oxides (e.g., titanium dioxide, zinc oxide), carbon-based materials (e.g., graphene, carbon nanotubes), ceramics, polymers, and nanoparticles of silver, copper, or gold.

- **Applications of Nanocoatings:**

- **Automotive Industry:** Nanocoatings are used to improve the exterior appearance and durability of automotive components. They offer scratch resistance, corrosion protection, and reduced wear on car surfaces.
- **Electronics:** Nanocoatings are applied to electronic devices to protect them from moisture, dust, and environmental contaminants. They also offer improved thermal management and can act as insulating or conducting layers in microelectronics.
- **Aerospace:** Nanocoatings are utilized in aerospace applications to enhance the performance of aircraft components. They offer anti-icing properties, reduce friction, and provide protection against harsh environmental conditions.
- **Medical Devices:** Nanocoatings find application in medical devices to improve biocompatibility and reduce the risk of infections. They can also provide controlled drug release for targeted therapies.
- **Textiles:** Nanocoatings are used in textiles to impart water repellency, stain resistance, and antibacterial properties. They can also enhance UV protection and improve the durability of fabrics.

- **Optics and Displays:** Nanocoatings are employed in optical lenses, displays, and mirrors to reduce reflection, improve light transmission, and increase scratch resistance.
- **Construction and Architecture:** Nanocoatings are used on building surfaces to provide self-cleaning properties, UV protection, and protection against environmental pollutants.
- **Advantages of Nanocoatings:**
 - **Enhanced Performance:** Nanocoatings offer superior properties, such as increased hardness, wear resistance, and improved electrical or thermal conductivity.
 - **Improved Durability:** Nanocoatings provide extended lifespan and protection against environmental degradation, reducing maintenance costs.
 - **Tailored Surface Properties:** Nanocoatings can be designed to provide specific surface properties, making them versatile for different applications.
 - **Sustainability:** Nanocoatings can lead to reduced material consumption and energy usage due to their thin nature and targeted functionality.

6. Energy Nanomaterials (Smart Panels):

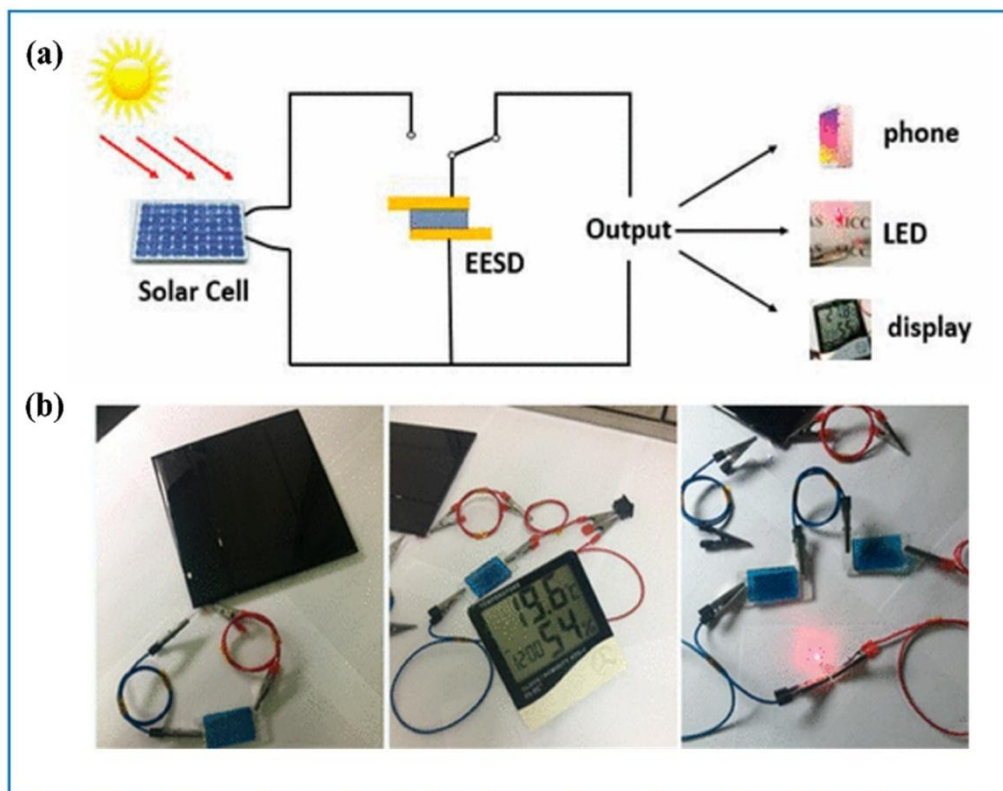

Nanotechnologies hold the promise of enhancing energy efficiency across diverse industries, utilizing renewable energy sources through innovative technological solutions and refined manufacturing processes. The progress in nanotechnology could potentially reverberate throughout the entire energy value chain, spanning energy sources, conversion, distribution, storage, and utilization.

Nanotechnology finds practical application in various modern devices, including smart panels used in contemporary TVs, laptop computers, digital cameras, cell phones, and more. This integration involves the utilization of nanostructured polymer films, specifically organic light-emitting diodes (OLEDs), renowned for their luminance efficiency and extended operational lifespans.

Energy nanomaterials are increasing the efficiency and affordability of energy storage, conservation, and production systems. Nanotexturing of existing energy components results in increased durability and, hence, provides energy savings. Nanocoatings with anti-reflective, wear-resistant, thermal-resistant, and corrosion-protective properties improve the quality of electrodes and solar cells, among others. Nanoparticles find applications in supercapacitors and lithium-ion (Li-ion) batteries. More recently, innovative nanocomposites, nanogels, and nanofoams find use in intelligent industrial and grid energy management.

- **Key Features of Energy Nanomaterials (Smart Panels):**

- **Increased Surface Area:** Energy nanomaterials have a high surface-to-volume ratio due to their nanoscale size and specific structures. This increased surface area allows for more efficient energy interactions, such as light absorption, chemical reactions, and charge storage.
- **Quantum Effects:** At the nanoscale, energy nanomaterials may exhibit quantum effects, such as quantum confinement and quantum tunneling. These effects can significantly influence the behavior of electrons and photons, leading to enhanced energy conversion and improved performance.
- **Tailored Properties:** Energy nanomaterials can be precisely engineered to possess specific properties, such as bandgap, conductivity, and catalytic activity. This tailorability allows researchers to design materials optimized for particular energy applications.
- **Versatility:** Energy nanomaterials can be integrated into various devices and systems, making them versatile for multiple energy-related applications.

- **Applications of Energy Nanomaterials (Smart Panels):**

- **Solar Cells:** Nanomaterials, like quantum dots and nanowires, are used to improve light absorption and electron transport in solar cells. These materials can increase the efficiency of converting sunlight into electricity.

- **Energy Storage:** Nanomaterials, such as nanocomposites and nanowires, are employed in batteries and supercapacitors to enhance energy storage capacity, charge-discharge rates, and overall performance.
 - **Fuel Cells:** Nanomaterials serve as catalysts in fuel cells to facilitate efficient electrochemical reactions, resulting in better energy conversion and reduced cost.
 - **Thermoelectric Devices:** Energy nanomaterials with high electrical conductivity and low thermal conductivity are used in thermoelectric devices to convert waste heat into electricity.
 - **Lighting and Displays:** Nanomaterials like quantum dots enable the development of more energy-efficient and high-quality displays and lighting sources.
- **Advantages of Energy Nanomaterials (Smart Panels):**
 - **Improved Efficiency:** Energy nanomaterials boost the efficiency of energy conversion and storage processes, leading to reduced energy losses and increased overall system efficiency.
 - **Enhanced Performance:** The unique properties of nanomaterials lead to improved performance in energy devices, resulting in longer battery life, faster charging, and better energy utilization.
 - **Sustainability:** Smart panels promote the use of renewable energy sources, contributing to a more sustainable and environmentally friendly energy ecosystem.
 - **Miniaturization:** The nanoscale size of these materials allows for the miniaturization of energy devices, making them more compact and suitable for various applications, including wearable technology.

IV. AEROSPACE NANOTECHNOLOGY

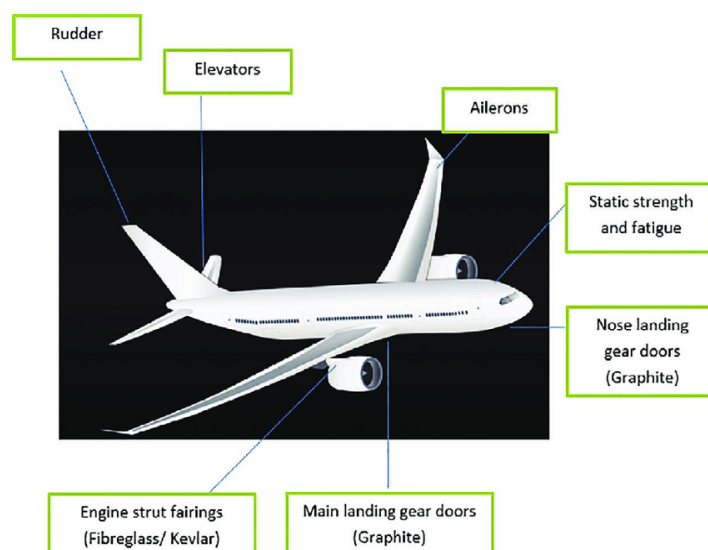

Aerospace is a branch of science and engineering that focuses on the application of nanotechnology in the aerospace industry. It involves the use of nanomaterials and nanoscale processes to enhance the performance, efficiency, and safety of aircraft, spacecraft, and related aerospace technologies. Aerospace nanotechnology has the potential to revolutionize the aerospace sector, enabling advancements in propulsion systems, lightweight materials, energy storage, and more.

Obviously, there would be significant advantages of materials that are 100 times stronger than present materials. Objects made from these materials could be up to 100 times lighter, using 100 times less of quantity of substance. By substituting diamondoid composite material this factor could be increased to about 250. As a result, ultra light cars, trucks, trains, aircraft, and spacecraft would use far less energy, especially with atomically smooth surfaces to reduce internal friction and air resistance losses. Space transportation costs could be reduced considerably with use of the products of nanotechnology.

Nanotechnology is poised to play a pivotal role in forthcoming space missions, as it harnesses nanosensors to elevate material performance and advances the realm of ultra-efficient propulsion systems utilized in aeronautics.

- 1. Key Areas of Aerospace Nanotechnology:** Nanomaterials for Aerospace Components: Nanotechnology enables the development of advanced materials with unique properties, such as carbon nanotubes, graphene, and nanocomposites. These materials are utilized in aerospace components, including airframes, wings, and engine parts, to enhance strength, reduce weight, and improve overall performance.
 - **Nanoengineered Coatings:** Nanocoatings are applied to aircraft surfaces to provide functionalities like anti-icing, anti-corrosion, and self-cleaning. These coatings protect aircraft from environmental degradation, reduce drag, and improve aerodynamic efficiency.
 - **Nanoelectronics and Sensors:** Nanotechnology plays a vital role in developing miniature sensors and nanoelectronics for aircraft health monitoring, avionics, and communication systems. Nanoscale sensors can detect structural damage, monitor engine performance, and improve aircraft safety.
 - **Nanofluids and Lubricants:** Nanoparticles dispersed in fluids can improve heat transfer and lubrication efficiency in aircraft engines and systems. Nanofluids can enhance the cooling of engine components and lead to better fuel efficiency.
 - **Energy Storage and Conversion:** Aerospace nanotechnology contributes to the development of lightweight and high-energy-density batteries and capacitors for electric aircraft and spacecraft applications.
 - **Nanoparticles in Propellants:** Nanoparticles can be used in rocket propellants to improve combustion efficiency and increase thrust, leading to more efficient propulsion systems for spacecraft.

- **Nanomaterials for Spacecraft Components:** Nanotechnology allows the creation of radiation-resistant materials and thermal protection systems for spacecraft, ensuring their survival and functionality in extreme space conditions.

2. Advantages of Aerospace Nanotechnology:

- **Weight Reduction:** The use of nanomaterials in aerospace components reduces weight, leading to increased fuel efficiency and extended flight range.
- **Enhanced Performance:** Nanotechnology enables the development of high-performance materials and coatings that improve the aerodynamics and thermal management of aircraft and spacecraft.
- **Improved Safety and Reliability:** Nanoscale sensors and monitoring systems enhance aircraft safety by detecting early signs of structural damage and potential failures.
- **Sustainability:** Lightweight and fuel-efficient aircraft contribute to reduced greenhouse gas emissions and a more sustainable aerospace industry.

3. Challenges and Future Prospects:

Aerospace nanotechnology faces challenges related to material scalability, cost-effectiveness, and safety. Research efforts are focused on addressing these challenges to facilitate the widespread adoption of nanotechnology in the aerospace sector.

As the field of nanotechnology advances, aerospace industries can look forward to more significant innovations, including faster and more fuel-efficient aircraft, enhanced space exploration capabilities, and increased safety and reliability of aerospace systems. Continued research and development in aerospace nanotechnology will play a pivotal role in shaping the future of flight and space exploration.

V. DISPLAY NANOTECHNOLOGY

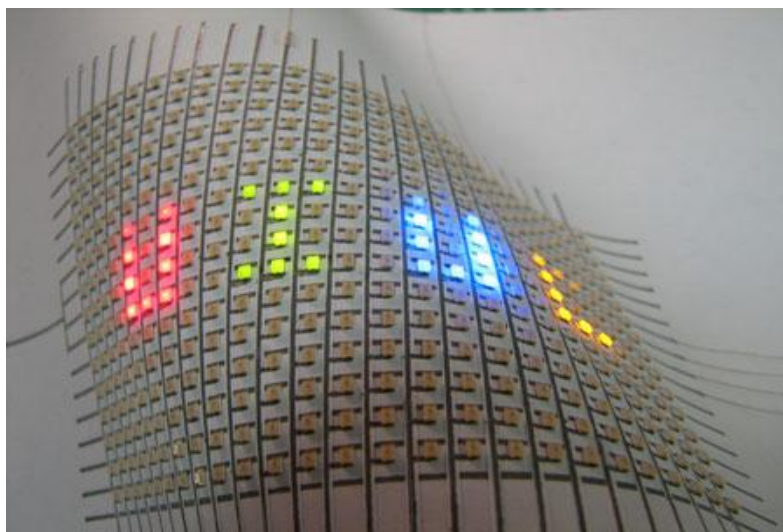

Display nanotechnology refers to the use of nanomaterials and nanoscale processes in the design and manufacturing of display technologies. It aims to enhance the performance, efficiency, and visual quality of displays used in various electronic devices, including smartphones, tablets, TVs, monitors, and wearables. By leveraging the unique properties of nanomaterials, display nanotechnology has led to significant advancements in screen technology, making screens thinner, brighter, and more energy-efficient.

Display technologies are fundamentally categorized into three main groups: organic LEDs, electronic paper, and other devices primarily designed for presenting static images. All of these categories crucially depend on the integration of nanomaterials and the utilization of nanofabrication processes.

1. Key Aspects and Applications of Display Nanotechnology:

- **Quantum Dots (QDs):** Quantum dots are semiconductor nanocrystals that emit light when excited by an external energy source, such as a backlight. QDs are employed in displays as color converters to enhance the color gamut, resulting in more vibrant and accurate colors. This technology is known as "Quantum Dot Enhancement Film" or "QLED" in some TVs.
- **Nanowires:** Nanowires, particularly transparent conducting nanowires like indium tin oxide (ITO) nanowires, are used in transparent electrodes for touchscreens. They offer better conductivity and mechanical flexibility, leading to more responsive and durable touch displays.
- **Nanoparticles for Light Management:** Nanoparticles are used in displays to improve light management, such as enhancing light extraction and diffusion, leading to better brightness, contrast, and viewing angles.
- **Nanocoatings for Anti-Reflective and Anti-Fingerprint Properties:** Nanocoatings are applied to display surfaces to reduce reflections and glare, leading to improved readability under various lighting conditions. These coatings also make displays more resistant to fingerprints and smudges.
- **Nanotechnology in OLEDs:** Organic Light Emitting Diodes (OLEDs) are display technologies that use organic materials to emit light. Nanotechnology plays a role in optimizing the efficiency and lifetime of OLEDs by improving charge transport and preventing device degradation.
- **Flexible and Foldable Displays:** Display nanotechnology contributes to the development of flexible and foldable displays using nanomaterials that can withstand repeated bending without performance degradation.

2. Advantages of Display Nanotechnology:

- **Enhanced Visual Quality:** Display nanotechnology improves color accuracy, brightness, and contrast, resulting in more lifelike and engaging visuals.

- **Energy Efficiency:** Nanomaterials in displays can lead to lower power consumption, increasing the energy efficiency of devices and extending battery life.
 - **Thinner and Lightweight Devices:** The use of nanomaterials allows for thinner and lighter displays, enabling sleeker and more portable electronic devices.
 - **Improved Readability:** Nanocoatings and light management technologies reduce reflections and glare, making displays easier to read in different lighting conditions.
- 3. Challenges and Future Prospects:** While display nanotechnology has brought about significant advancements in screen technology, there are still challenges to address. Manufacturing large-scale displays using nanomaterials can be complex and costly. Moreover, ensuring the stability and longevity of nanotechnology-based displays over extended usage remains an area of ongoing research.

Looking ahead, display nanotechnology holds the potential for further innovation in the field of visual displays. Advancements in materials science and fabrication techniques are expected to drive continuous improvements in display technology, offering consumers even more immersive, energy-efficient, and visually stunning electronic devices.

VI. MOLECULAR ELECTRONICS

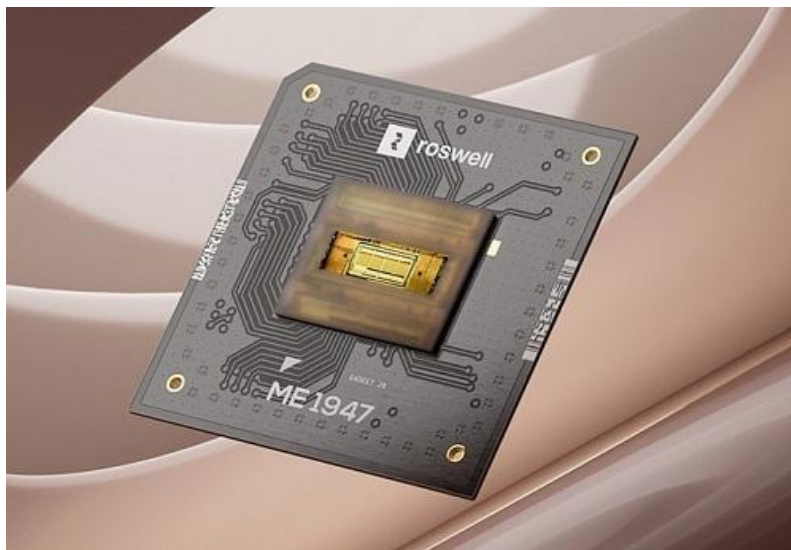

Molecular electronics is a branch of nanotechnology that focuses on the study and development of electronic components and devices at the molecular scale. Unlike traditional silicon-based electronics, molecular electronics aims to utilize individual molecules or molecular structures as the building blocks of electronic circuits. This field explores the use of molecules as functional units to perform various electronic functions, such as computation, data storage, and signal processing.

Recent advances in nanofabrication techniques have provided the opportunity to use single molecules, or a tiny assembly of them, as the main building blocks of an electronic

circuit. This, combined with the developed tools of molecular synthesis to engineer basic properties of molecules, has enabled the realization of novel functionalities beyond the scope of traditional solid state devices.

1. Key Concepts and Components of Molecular Electronics:

- **Molecular Wires:** Molecular wires are single molecules or chains of molecules that exhibit electrical conductivity. They can conduct charges and act as nanoscale interconnects between electronic components.
- **Molecular Switches:** Molecular switches are molecules that can change their conductive state (on/off) in response to external stimuli, such as voltage, light, or temperature. These switches are crucial for molecular logic circuits and memory devices.
- **Molecular Diodes:** Molecular diodes are non-linear electronic components that allow the flow of current in one direction, similar to traditional diodes used in semiconductor electronics.
- **Molecular Transistors:** Molecular transistors are the fundamental building blocks of molecular electronics. They function similarly to conventional transistors but use single molecules as the active semiconductor component.
- **Molecular Memories:** Molecular electronics aims to create memory devices based on molecules, offering the potential for extremely high-density data storage.

2. Advantages of Molecular Electronics:

- **Miniaturization:** Molecular electronics offers the potential for even smaller electronic components, enabling the development of ultra-compact and high-density devices.
- **Energy Efficiency:** The energy consumption of molecular electronics can be significantly lower than traditional electronics due to reduced resistance and power requirements at the molecular scale.
- **High-Speed Devices:** Molecular electronics has the potential to create devices with extremely fast switching speeds and processing capabilities.
- **Sustainability:** Molecular electronics can be constructed using organic and bio-inspired materials, offering potential eco-friendly and biodegradable electronic components.

3. Challenges and Current Status: Despite its promise, molecular electronics is still in the early stages of development, and several challenges need to be addressed:

- **Fabrication Techniques:** The precise placement of individual molecules on a surface to create functional circuits remains a significant challenge.

- **Stability and Reliability:** Ensuring the stability and long-term reliability of molecular electronic components is a crucial area of research.
 - **Integration with Traditional Electronics:** Integrating molecular electronics with conventional semiconductor technologies is complex due to differences in materials and manufacturing processes.
 - **Cost and Scalability:** The high cost and limited scalability of molecular electronics production hinder its practical implementation for large-scale commercial applications.
- 4. Current Research and Applications:** Molecular electronics is a highly interdisciplinary field involving chemistry, physics, materials science, and engineering. Researchers are actively exploring new materials, self-assembly techniques, and measurement methods to advance the development of molecular electronic devices.

While molecular electronics is still a nascent technology, researchers envision potential applications in future computing, ultra-dense data storage, and energy-efficient electronics. As research progresses and the challenges are overcome, molecular electronics could play a transformative role in shaping the future of electronic devices and computing technologies.

VII. QUANTUM COMPUTING

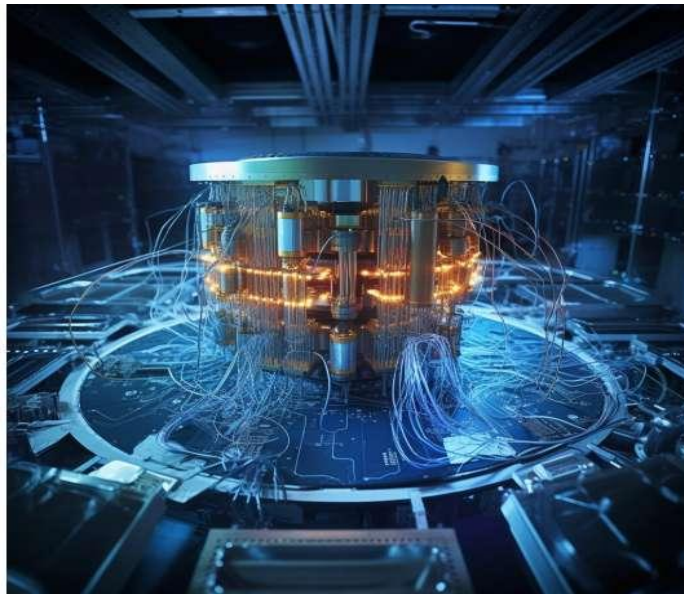

Quantum computing is a revolutionary field of computing that leverages the principles of quantum mechanics to perform complex calculations and solve problems that are beyond the capabilities of classical computers. Unlike classical computers that use bits to represent either 0 or 1, quantum computers use quantum bits or qubits, which can exist in multiple states simultaneously due to the phenomenon known as superposition. This unique property enables quantum computers to process vast amounts of information in parallel and tackle computationally intensive tasks with unparalleled efficiency.

The excitement in the field of quantum computing was triggered in 1994 by Peter Shor who showed how a quantum algorithm could exponentially speed up a classical computation. Such algorithms are implemented in a device that makes direct use of quantum mechanical phenomena such as entanglement and superposition. Since the physical laws that govern the behaviour of a system at the atomic scale are inherently quantum mechanical in nature, nanotechnology has emerged as the most appropriate tool to realize quantum computers.

1. Key Concepts of Quantum Computing:

- **Superposition:** Qubits can exist in a state of superposition, representing both 0 and 1 simultaneously. This allows quantum computers to perform many calculations at once, exponentially increasing their computational power.
- **Entanglement:** Quantum entanglement is a phenomenon where the states of multiple qubits become correlated, regardless of the physical distance between them. Entanglement enables quantum computers to perform complex operations and communications with exceptional efficiency.
- **Quantum Gates:** Quantum gates are the equivalent of classical logic gates in quantum computing. They manipulate qubits to perform quantum operations, such as superposition, entanglement, and phase shifts.
- **Quantum Algorithms:** Quantum computing relies on specialized quantum algorithms that exploit the unique properties of qubits to solve certain problems exponentially faster than classical algorithms. One example is Shor's algorithm, which can efficiently factor large numbers, threatening the security of classical encryption schemes.

2. Potential Applications of Quantum Computing:

- **Cryptography and Security:** Quantum computers have the potential to break commonly used cryptographic protocols, such as RSA and ECC. On the other hand, quantum cryptography offers secure communication methods based on the principles of quantum mechanics.
- **Optimization and Simulation:** Quantum computing can optimize complex systems and simulations, such as optimizing supply chains, financial portfolios, and drug discovery processes.
- **Machine Learning and AI:** Quantum algorithms could accelerate certain machine learning tasks and improve artificial intelligence algorithms.
- **Materials Science and Drug Design:** Quantum computing can simulate the behavior of molecules and materials, facilitating drug discovery and material design.

3. Challenges and Current Status: Quantum computing is still in its early stages of development, and several challenges need to be addressed:

- **Decoherence:** Qubits are sensitive to environmental noise, leading to decoherence, which can cause errors in calculations. Error correction and fault-tolerance are critical for building large-scale quantum computers.
- **Scalability:** Building large-scale quantum computers with many qubits and quantum gates is a major engineering challenge.
- **Hardware Limitations:** Current quantum computers have limited coherence times and are prone to errors, making them suitable for specific tasks but not yet fully competitive with classical computers.

4. Current Research and Progress: Despite the challenges, quantum computing has significant progress in recent years. Quantum computers with a few dozen qubits are already available from companies like IBM, Google, and Rigetti Computing. Quantum supremacy, the milestone where a quantum computer outperforms the most powerful classical supercomputer in a specific task, was achieved by Google in 2019. Research is ongoing in developing error-corrected qubits, novel quantum algorithms, and better quantum hardware.

As quantum computing continues to advance, it holds the promise of transforming various industries and solving complex problems that were once considered intractable with classical computing. However, it will likely be several years before practical and widespread applications of quantum computing become a reality.

VIII. SINGLE ELECTRON TRANSISTOR

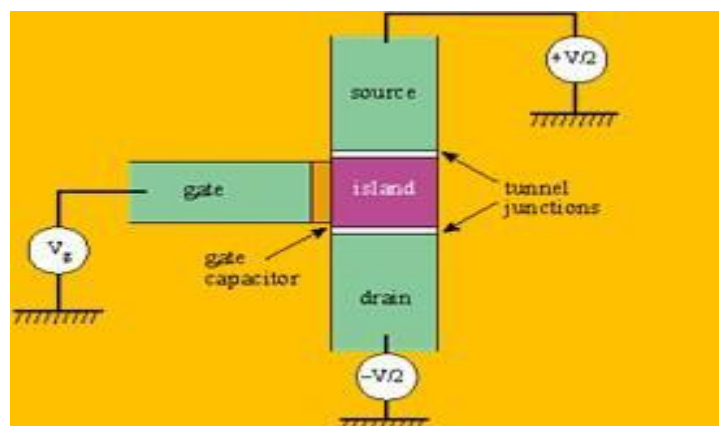

A Single Electron Transistor (SET) is a nanoscale electronic device that controls the flow of individual electrons, allowing for extremely sensitive and precise electronic manipulation. It operates by controlling the tunneling of single electrons through a small island or quantum dot, situated between two conducting electrodes.

In contrast to common transistors, where the switching action requires thousands of electrons, a single electron transistor needs only one electron to change from the insulating to

the conducting state. Such transistors can potentially deliver very high device density and power efficiency with remarkable operational speed. In order to implement single electron transistors, extremely small metallic islands with sub-100 nm dimensions have to be fabricated. These islands, which are referred to as quantum dots, can be fabricated by employing processes made available by the advances in nanotechnology.

Nanotechnology helps to create nanoscale transistors. These are quicker and more energy-efficient. Soon, the computer's whole memory may be stored on a single tiny chip.

1. Key Features of Single Electron Transistors:

- **Quantum Dot:** The heart of a Single Electron Transistor is the quantum dot or the small island. It is typically made of a semiconducting material and is isolated from the rest of the circuit. The size of the quantum dot determines the energy levels and the number of electrons it can hold.
 - **Source and Drain Electrodes:** These are the two conducting electrodes on either side of the quantum dot. They are responsible for supplying and receiving electrons to and from the quantum dot.
 - **Gate Electrode:** The gate electrode controls the number of electrons on the quantum dot by adjusting the electrostatic potential. Changing the gate voltage allows or prohibits the tunneling of single electrons through the quantum dot.
2. **Working Principle:** In a Single Electron Transistor, the quantum dot acts as a coulomb blockade device, meaning it can only allow the flow of electrons one by one due to the energy barrier between the quantum dot and the source/drain electrodes. When the gate voltage is low, the energy level of the quantum dot remains higher than that of the source and drain electrodes, preventing electrons from tunneling through.

As the gate voltage is raised, the energy level of the quantum dot aligns with that of the electrodes, enabling single-electron tunneling. This tunable tunneling effect makes SETs highly sensitive to changes in gate voltage, making them suitable for various applications.

3. Applications of Single Electron Transistors:

- **Single-Electron Devices:** SETs are used as fundamental building blocks for single-electron devices, such as single-electron memory cells and single-electron logic circuits.
- **Sensing and Metrology:** SETs can be employed as ultrasensitive electrometers and charge detectors, enabling the detection of extremely weak signals and small electrical charges.
- **Quantum Computation:** Single Electron Transistors have potential applications in quantum computing as qubits, the basic unit of quantum information processing.

- **Frequency Metrology:** SETs can be utilized in high-precision frequency metrology due to their ability to detect single-electron charge oscillations.
- 4. Challenges and Limitations:** While Single Electron Transistors have unique advantages, they also face some challenges:
- **Temperature Sensitivity:** SETs are highly sensitive to temperature changes, which can affect their performance and stability.
 - **Noise:** Noise sources, such as charge fluctuations and external electromagnetic interference, can impact the accuracy and reliability of SETs.
 - **Fabrication Complexity:** The fabrication of SETs with precise control over quantum dot characteristics can be challenging and complex.
 - **Despite these challenges,** Single Electron Transistors hold great promise for future nanoelectronics and quantum technologies. Ongoing research and advancements in nanofabrication techniques are expected to address current limitations and unlock even more innovative applications for SETs in various fields of science and technology.

IX. NANOCOMPOSITES

Nanocomposites are a class of materials composed of a combination of nanoparticles or nanofillers dispersed within a matrix material. These nanofillers are typically nanoparticles with at least one dimension in the nanometer range. The incorporation of nanoparticles into the matrix material imparts unique properties and functionalities, making nanocomposites highly versatile and suitable for various applications across multiple industries.

Nanocomposites like metal-organic framework (MOF) crystals, carbon fiber reinforced polymers (CFRP), and nanoceramics increasingly find use in automotive and aerospace industries. Innovations in metal and polymer matrix nanocomposites are making their manufacturing easier with techniques like 3D printing. Further, nano-reinforcement alters the microscopic properties of standard materials. This allows researchers to create nanocomposites with a higher surface-to-volume ratio as well as superior mechanical and optical characteristics. Startups leverage nanocomposites in various ways, including coatings, additives, catalysts, and structural components. Biotech startups are also developing polymer and organic nanocomposites for tissue engineering, regenerative medicine, drug delivery, and cellular therapies.

1. Key Features and Types of Nanocomposites:

- **Enhanced Mechanical Properties:** The addition of nanoparticles can significantly improve the mechanical properties of the nanocomposite, such as increased strength, stiffness, and toughness.
- **Improved Thermal Stability:** Nanocomposites exhibit enhanced thermal stability due to the high surface area and thermal conductivity of nanoparticles.

- **Enhanced Electrical Conductivity or Insulation:** Depending on the type of nanoparticles used, nanocomposites can display improved electrical conductivity or act as excellent electrical insulators.
- **Barrier Properties:** Nanocomposites can have superior barrier properties against gases and liquids, making them useful in packaging materials and coatings.
- **Optical Properties:** Nanoparticles can modify the optical properties of nanocomposites, leading to changes in transparency, light scattering, and absorption.

2. Types of Nanocomposites:

- **Polymer Nanocomposites:** Polymer matrices with nanoparticles dispersed within them. Examples include clay-polymer nanocomposites and carbon nanotube-polymer composites.
- **Metal Matrix Nanocomposites:** Metal matrices containing nanoparticles for improved strength and wear resistance.
- **Ceramic Nanocomposites:** Ceramic matrices with nanoparticles to enhance mechanical and thermal properties.
- **Carbon Nanotube Composites:** Composites where carbon nanotubes are used as the nanofillers to improve mechanical, thermal, and electrical properties.

3. Applications of Nanocomposites:

- **Automotive and Aerospace:** Nanocomposites are used in vehicle components to reduce weight while maintaining mechanical strength and improving fuel efficiency.
- **Packaging Materials:** Nanocomposite films and coatings enhance barrier properties, extending the shelf life of packaged products.
- **Electronics:** Nanocomposites are utilized in electronic devices to enhance thermal management and electrical performance.
- **Medical Devices:** Nanocomposites are used in medical implants and prosthetics for improved biocompatibility and mechanical strength.
- **Construction:** Nanocomposites find applications in construction materials for improved durability and thermal insulation.
- **Textiles:** Nanocomposite coatings provide fabrics with enhanced water repellency, antimicrobial properties, and UV resistance.
- **Energy Applications:** Nanocomposites are used in batteries, fuel cells, and solar cells for improved performance and efficiency.

- ## 4. Challenges and Future Directions:
- While nanocomposites offer significant benefits, challenges include maintaining the uniform dispersion of nanoparticles within the matrix, scalability, and cost-effectiveness of large-scale production. Further research is ongoing to optimize nanocomposite properties, develop novel nanofillers, and improve processing techniques.

In conclusion, nanocomposites are a promising class of materials with vast potential for diverse applications in various industries. As nanotechnology continues to advance, nanocomposites are expected to play an increasingly important role in addressing various engineering challenges and enhancing the performance of existing materials and products.

X. Carbon-Based Sensors:

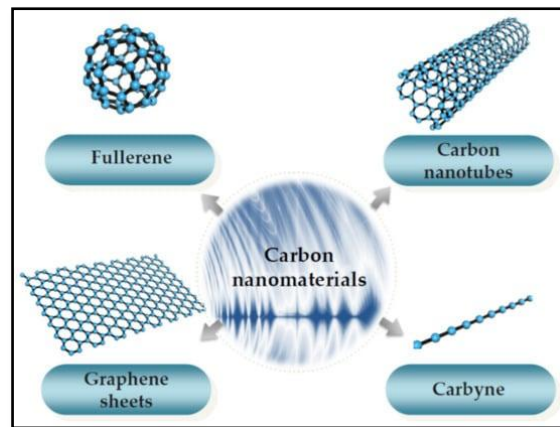

Carbon-based sensors refer to a category of sensing devices that utilize carbon-based materials as their primary sensing element. Carbon-based materials are attractive for sensor applications due to their unique properties, such as high surface area, chemical stability, electrical conductivity, and biocompatibility. These sensors find applications in various fields, including Nanotechnology finds applications in a diverse range of fields, including environmental monitoring, healthcare, industrial process control, and consumer electronics.

The semiconductor industry has been able to improve the performance of electronic systems for more than four decades by downscaling silicon-based devices but this approach will soon encounter its physical and technical limits. This fact, together with increasing requirements for performance, functionality, cost, and portability have been driven the microelectronics industry towards the nano world and the search for alternative materials to replace silicon. Carbon nano-materials such as one-dimensional (1D) carbon nano-tubes and two-dimensional (2D) graphene have emerged as promising options due to their superior electrical properties which allow for fabrication of faster and more power-efficient electronics. At the same time their high surface to volume ratio combined with their excellent mechanical properties has rendered them a robust and highly sensitive building block for nano-sensors.

Carbon-Based Nano-Sensors In addition to the exceptional electrical properties of graphene and carbon nano-tubes, their excellent thermal conductivity, high mechanical robustness, and very large surface to volume ratio make them superior materials for fabrication of electromechanical and electrochemical sensors with higher sensitivities, lower limits of detection, and faster response time. A good example is the carbon nano-tube based mass sensor that can detect changes in mass caused by a single gold atom adsorbing on its surface.

Startups are continuously developing new methods and improving conventional methods such as carbon-vapor deposition (CVD) to synthesize carbon nanomaterials. This is enabling the development of carbon nanostructures with higher mechanical strength, chemical stability, durability, and flexibility compared to conventional materials. Graphene, carbon dots, and carbon nanotubes (CNTs) are some carbon nanomaterials that find use in electronics, tissue engineering, and textiles. Single and multi-walled carbon nanotubes (SWCNTs and MWCNTs) provide low resistance conductivity and therefore serve as nanofillers to develop electronic structures. Startups also use carbon-based nano additives like graphene-integrated catalysts, nanodiamonds, and carbon nanofibers to develop reinforced materials.

1. Types of Carbon-Based Sensors:

- **Carbon Nanotube Sensors:** Carbon nanotubes (CNTs) are cylindrical carbon structures with exceptional electrical conductivity. CNT-based sensors can detect changes in electrical properties caused by interactions with target molecules, making them suitable for gas sensing, biosensing, and environmental monitoring.
- **Graphene Sensors:** Graphene is a single layer of carbon atoms arranged in a 2D lattice, known for its high electrical conductivity and large surface area. Graphene-based sensors are highly sensitive and can detect a wide range of analytes, including gases, biomolecules, and chemicals.
- **Carbon Nanofiber Sensors:** Carbon nanofibers are carbon-based materials with high aspect ratios and good electrical conductivity. They are used in sensors for strain, pressure, and gas sensing applications.
- **Carbon Black Sensors:** Carbon black is a fine powder of carbon particles with a large surface area. It is commonly used in gas sensors, such as carbon monoxide (CO) sensors.

2. Applications of Carbon-Based Sensors:

- **Gas Sensing:** Carbon-based sensors are widely used for gas detection, including monitoring air quality, detecting toxic gases, and industrial process control.
- **Biosensing:** Carbon-based sensors can be functionalized with biological molecules to detect specific biomarkers, enabling applications in medical diagnostics and healthcare.
- **Strain and Pressure Sensing:** Carbon-based sensors can measure mechanical deformation, strain, and pressure, finding applications in structural health monitoring and wearable devices.
- **Chemical Sensing:** Carbon-based sensors can detect a wide range of chemicals and analytes, making them useful in industrial and environmental monitoring.

- **Temperature Sensing:** Carbon-based sensors can be utilized for temperature measurement due to their electrical conductivity changes with temperature.

3. Advantages of Carbon-Based Sensors:

- **High Sensitivity:** Carbon-based materials exhibit high sensitivity to various analytes, enabling precise and accurate detection.
- **Fast Response Time:** Carbon-based sensors often have rapid response and recovery times, allowing real-time monitoring.
- **Miniaturization and Flexibility:** Carbon-based sensors can be fabricated into small, flexible, and lightweight devices, suitable for wearable and portable applications.
- **Low-Cost Production:** Carbon-based materials can be synthesized through cost-effective methods, making the production of carbon-based sensors more economically viable.

4. **Challenges and Future Directions:** While carbon-based sensors offer many advantages, challenges include selectivity (discriminating specific analytes from complex mixtures), stability, and reproducibility. Researchers are working to improve the performance and selectivity of carbon-based sensors through advanced materials engineering, surface functionalization, and integration with signal processing technologies.

In the future, carbon-based sensors are expected to play an increasingly important role in various emerging technologies, such as the Internet of Things (IoT), wearable devices, and personalized healthcare, contributing to advancements in monitoring and enhancing our understanding of the surrounding environment and biological systems.

XI. NANOSENSORS

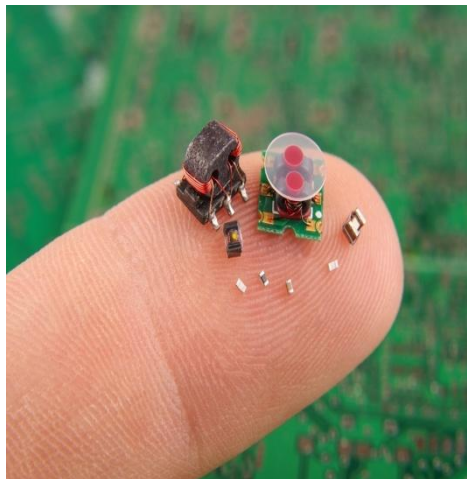

Nanosensors are a class of sensors that utilize nanotechnology to detect and measure changes in physical, chemical, or biological properties at the nanoscale level. These tiny devices have unique properties due to their nanosize and offer exceptional sensitivity, selectivity, and responsiveness, enabling the detection of even minute changes in the environment. Nanosensors have applications across various fields, including healthcare, environmental monitoring, food safety, and industrial process control.

Startups are creating nanometer-scale electrochemical and mechanical sensors for molecular-level detection and sensing. Nanolithography, molecular self-assembly, and bottom-up assembly are common techniques to produce these nanosensors. Nanoenhanced lab-on-a-chip solutions and nanoelectromechanical systems (NEMS) are advancing DNA analysis, proteomics, atomic force microscopy, and disease detection. Further, they find use in injectable biosensors and brain-computer interfaces for personalized treatments. Likewise, nanobiosensors in wearables provide critical health data for worker and public safety. Smart nanosensors are also enabling contamination detection, environmental measurements, remote sensing, and communication.

1. Key Features and Types of Nanosensors:

- **Nanoscale Size:** Nanosensors typically consist of nanomaterials or nanocomposites, which provide a large surface-to-volume ratio, enhancing sensitivity to analytes.
- **Surface Functionalization:** Nanosensors can be functionalized with specific molecules to improve selectivity and allow the detection of specific target substances.
- **Optical, Electrical, and Mechanical Properties:** Nanosensors can operate based on different principles, such as changes in optical properties (e.g., fluorescence), electrical conductivity, or mechanical responses.
- **Quantum Effects:** At the nanoscale, quantum effects can influence the behavior of nanosensors, leading to unique and improved sensing capabilities.

2. Types of Nanosensors:

- **Chemical Nanosensors:** These sensors detect changes in chemical properties, such as pH, concentration of gases, ions, or organic compounds.
- **Biological and Medical Nanosensors:** Nanosensors can be used in medical diagnostics to detect biomarkers for diseases or monitor drug delivery processes.
- **Environmental Nanosensors:** These sensors are employed in environmental monitoring to detect pollutants, toxins, and other environmental parameters.
- **Nanomechanical Sensors:** These sensors operate based on the mechanical responses of nanomaterials to changes in the environment, such as strain, pressure, or mass.

3. Applications of Nanosensors:

- **Healthcare and Medical Diagnostics:** Nanosensors are used for early detection of diseases, monitoring drug delivery, and analyzing biomarkers in bodily fluids.
- **Environmental Monitoring:** Nanosensors help in monitoring air and water quality, detecting pollutants, and assessing environmental hazards.
- **Food Safety:** Nanosensors are used in the food industry to detect contaminants and ensure the safety and quality of food products.
- **Industrial Process Control:** Nanosensors are employed in industrial settings to monitor process parameters, optimize efficiency, and detect potential hazards.
- **Security and Defense:** Nanosensors can be used for detecting hazardous materials, explosives, and chemical warfare agents.

4. Advantages of Nanosensors:

- **High Sensitivity:** Nanosensors can detect very low concentrations of analytes, enabling early detection and precise measurements.
- **Miniaturization:** Nanosensors are small and lightweight, making them suitable for integration into portable and wearable devices.
- **Real-time Monitoring:** Nanosensors provide real-time data, enabling immediate response to changes in the environment.
- **Selectivity:** By functionalizing the sensor surface, nanosensors can be highly selective, detecting specific target substances amidst complex mixtures.

5. Challenges and Future Directions: Nanosensor development faces challenges related to scalability, stability, and reproducibility. Ensuring the safe use and disposal of nanosensors is also an important consideration. Researchers are continuously working to address these challenges and explore novel nanomaterials and fabrication techniques to improve nanosensor performance.

As nanotechnology advances, nanosensors are expected to revolutionize various industries by enabling more efficient and accurate monitoring of our surroundings, leading to improved healthcare, environmental protection, and industrial processes. However, responsible development and deployment of nanosensors are crucial to ensure their safe and ethical integration into modern technologies.

XII. PRINTED ELECTRONICS

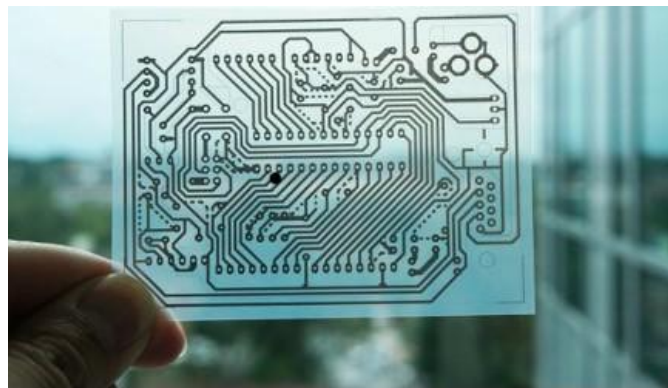

Printed electronics is an emerging technology that involves the printing of electronic components and circuits onto flexible substrates using various printing techniques. This innovative approach allows for the low-cost, high-volume production of electronic devices and systems, enabling the integration of electronics into a wide range of products and applications.

Nanotechnology is employed in the realm of printed electronics, encompassing RFID technology, smart cards, and intelligent packaging. Additionally, it contributes to the realization of immersive video games and the creation of flexible displays tailored for e-books.

1. Key Features and Components of Printed Electronics:

- **Printable Materials:** Conductive, semiconductive, and dielectric inks are used as printable materials. These inks are formulated to be compatible with printing techniques such as screen printing, inkjet printing, and roll-to-roll printing.
- **Flexible Substrates:** Printed electronics are typically produced on flexible substrates such as plastic, paper, or even fabric, enabling the creation of lightweight, bendable, and conformable electronic devices.
- **Organic Electronics:** Printed electronics often utilize organic materials, such as organic semiconductors and conductive polymers, to create transistors, light-emitting diodes (LEDs), and other electronic components.
- **Low-Temperature Processing:** Printed electronics can be manufactured at relatively low temperatures, making them compatible with flexible substrates and reducing energy consumption during production.

2. Applications of Printed Electronics:

- **Flexible Displays:** Printed electronics enable the creation of flexible, rollable, and foldable displays for wearable devices, e-paper, and smart packaging.
- **RFID Tags:** Radio Frequency Identification (RFID) tags and sensors can be printed on labels, enabling cost-effective and efficient tracking and monitoring in logistics and supply chain management.
- **Smart Packaging:** Printed electronics can be integrated into packaging to provide interactive features, such as temperature indicators, freshness sensors, and product authentication.
- **Wearable Electronics:** Printed electronics are ideal for creating lightweight and flexible electronic components in wearable devices, such as fitness trackers and smart clothing.
- **Energy Harvesting and Storage:** Printed electronics can be used to create energy harvesting devices and printed batteries for low-power applications.
- **Sensors and Internet of Things (IoT):** Printed sensors, including temperature, humidity, and gas sensors, can be integrated into IoT devices for environmental monitoring and smart home applications.

3. Advantages of Printed Electronics:

- **Low-Cost Production:** Printed electronics offer a cost-effective alternative to traditional semiconductor manufacturing, especially for large-area, low-performance devices.

- **Rapid Prototyping:** Printing techniques allow for rapid prototyping and fast iteration, accelerating the development of new electronic products.
 - **Lightweight and Flexible:** Printed electronics can be produced on flexible substrates, enabling the creation of lightweight, conformable devices that can be integrated into various form factors.
 - **Sustainability:** Printed electronics can potentially reduce material waste compared to conventional manufacturing processes.
- 4. Challenges and Future Directions:** Despite the promise of printed electronics, there are challenges to address:
- **Performance and Stability:** Printed electronics currently have lower performance and stability compared to traditional silicon-based electronics, limiting their use in high-performance applications.
 - **Ink Formulation and Compatibility:** Developing printable materials with desired properties and ensuring compatibility between different inks and printing techniques is essential.
 - **Scale-up and Manufacturing:** Scaling up printed electronics to mass production levels while maintaining consistency and reliability is a significant challenge.

As research and development continue, advances in printed electronics are expected to lead to improved performance, reliability, and versatility, expanding their applications and making them increasingly integrated into our daily lives.

XIII. TRANSISTORS ON THE NANOSCALE

Transistors on the nanoscale refer to electronic devices that have critical dimensions in the nanometer range. These nanoscale transistors are a result of advancements in nanotechnology and semiconductor fabrication techniques. The miniaturization of transistors to the nanoscale has enabled higher integration density, improved performance, and reduced power consumption in electronic devices, leading to the continued advancement of modern technology.

The application of nanotechnology facilitates the development of nanoscale transistors, which exhibit heightened speed, increased potency, and enhanced energy efficiency. In the near future, it's conceivable that an entire computer's memory could be housed on a single minuscule chip.

1. Key Types of Nanoscale Transistors:

- **FinFET Transistors:** FinFETs, short for Fin Field-Effect Transistors, are a type of 3D transistor structure that has a fin-like channel. FinFETs offer better control over the flow of current, reducing leakage and improving performance compared to traditional planar transistors.

- **Gate-All-Around (GAA) Transistors:** GAA transistors are another form of 3D transistors, where the channel is fully surrounded by the gate. GAA transistors provide even better control over the channel and offer excellent electrostatic integrity.
 - **Carbon Nanotube Transistors:** Carbon nanotube transistors use carbon nanotubes as the channel material. They have excellent electrical properties and are potential replacements for silicon-based transistors in the future.
 - **Graphene Transistors:** Graphene transistors utilize graphene as the core channel material. Graphene, comprising a lone layer of carbon atoms organized within a two-dimensional lattice, boasts exceptional electrical characteristics. However, the task of addressing challenges in bandgap engineering remains imperative for realizing its practical applications.
- 2. Challenges and Advancements:** As transistors continue to shrink to the nanoscale, several challenges arise:
- **Quantum Effects:** At the nanoscale, quantum effects become more pronounced, leading to issues like electron tunneling and variations in device performance.
 - **Heat Dissipation:** Nanoscale transistors generate more heat per unit area, making efficient heat dissipation critical to maintaining device reliability.
 - **Manufacturing Complexity:** Fabricating nanoscale transistors requires advanced lithography and etching techniques, increasing manufacturing complexity and cost.
 - Despite these challenges, researchers and engineers have made significant advancements in nanoscale transistor technology:
 - **Moore's Law:** Moore's Law, which predicts a doubling of transistor density approximately every two years, has driven the semiconductor industry to push the limits of nanoscale transistor fabrication.
 - **Advanced Materials:** The exploration of new materials, such as carbon nanotubes, graphene, and other 2D materials, has opened up new possibilities for nanoscale transistors.
 - **Quantum Computing:** Nanoscale transistors are a crucial component in the development of quantum computing, enabling the manipulation and control of qubits.
- 3. Applications of Nanoscale Transistors:** Nanoscale transistors have found applications in various electronic devices and technologies, including:
- **Microprocessors:** Nanoscale transistors enable the production of powerful microprocessors with higher performance and energy efficiency.
 - **Memory Devices:** Nanoscale transistors are used in memory devices like SRAM and DRAM, enabling higher storage density and faster access times.

- **Communications:** Nanoscale transistors are employed in communication devices, such as smartphones and networking equipment, for improved performance and power efficiency.
- **Quantum Computing:** Quantum computers rely on nanoscale transistors to manipulate qubits and perform quantum operations.

In summary, nanoscale transistors have revolutionized the electronics industry, driving the advancement of technology in various sectors. Continued research and innovation in nanotechnology will likely lead to even smaller and more efficient transistors, paving the way for future technological breakthroughs.

XIV. SMALLER AND ENHANCED HANDHELD DEVICES



Smaller and enhanced handheld devices refer to a trend in consumer electronics where portable gadgets, such as smartphones, tablets, and wearable devices, are continuously shrinking in size while simultaneously offering improved features, performance, and functionality. This trend is driven by advancements in technology, particularly in nanotechnology, microelectronics, and materials science. Smaller and enhanced handheld devices have become an integral part of modern life, offering convenience, connectivity, and versatility to users.

Nanotechnology integrated into electronics paves the way for swifter, more compact, and highly potent handheld devices. Additionally, it ushers in novel display technologies, encompassing products forged from highly conductive nanomaterials, advanced data storage solutions, quantum computing advancements, as well as printable and flexible electronics. Furthermore, nanotechnology facilitates the utilization of magnetic nanoparticles for data storage purposes.

1. Key Features and Advancements:

- **Miniaturization:** Handheld devices are becoming smaller and thinner, allowing for more portable and pocket-friendly gadgets.
- **Increased Processing Power:** Advancements in microelectronics and chip fabrication techniques have led to more powerful processors, enabling faster performance and multitasking capabilities.
- **High-Resolution Displays:** Handheld devices now boast high-resolution displays with vibrant colors and sharp visuals, enhancing the user experience.
- **Longer Battery Life:** Improved battery technologies, along with power-efficient processors and displays, have extended the battery life of handheld devices, reducing the need for frequent recharging.
- **Connectivity:** Smaller devices now offer enhanced connectivity options, such as 5G, Wi-Fi 6, Bluetooth, and NFC, enabling seamless data transfer and internet connectivity.
- **Sensors and Biometrics:** Handheld devices feature advanced sensors, including fingerprint scanners, facial recognition, and motion sensors, for improved security and user interaction.
- **Camera Capabilities:** Miniaturized devices now come with high-resolution cameras, optical image stabilization, and advanced imaging software for impressive photography and videography.
- **Integration of AI and Machine Learning:** AI and machine learning algorithms are integrated into handheld devices, enabling smarter voice assistants, improved camera features, and personalized user experiences.

2. Applications and Impact: Smaller and enhanced handheld devices have had a profound impact on various aspects of daily life and industries:

- **Communication and Connectivity:** Smartphones and other handheld devices enable real-time communication, social networking, and internet browsing, enhancing connectivity and information access.
- **Mobile Computing:** Enhanced processing power and multitasking capabilities allow users to perform a wide range of computing tasks on the go, from office work to entertainment.
- **Health and Fitness:** Wearable devices with health-tracking features help users monitor their physical activities, heart rate, sleep patterns, and overall health.
- **E-Commerce and Online Shopping:** Handheld devices have facilitated the growth of e-commerce, allowing users to shop and make transactions conveniently.

- **Education:** Enhanced handheld devices have transformed education, providing access to digital learning resources and enabling remote learning opportunities.
- **Navigation and Mapping:** Built-in GPS and mapping applications in handheld devices offer reliable navigation and location-based services.

3. Challenges and Future Trends: While smaller and enhanced handheld devices offer numerous benefits, some challenges include:

- **Battery Life:** As devices become more powerful, optimizing battery life remains crucial for a seamless user experience.
- **Data Security and Privacy:** With increased connectivity and personal data storage on devices, data security and privacy concerns are paramount.
- **Sustainability:** The constant upgrading and disposal of electronic devices raise concerns about electronic waste and the environmental impact.

Future trends in smaller and enhanced handheld devices include:

- **Foldable and Flexible Displays:** Devices with foldable and flexible displays offer a balance between screen size and portability.
- **Augmented Reality (AR) and Virtual Reality (VR):** Handheld devices will play a crucial role in the adoption of AR and VR technologies, providing immersive experiences to users.
- **Biometric Integration:** More secure and seamless biometric authentication methods, such as under-display fingerprint scanners and facial recognition, will become prevalent.
- **Internet of Things (IoT) Integration:** Handheld devices will increasingly serve as control centers for IoT devices, managing smart homes and connected appliances.

In conclusion, smaller and enhanced handheld devices continue to shape the way we interact with technology and each other. The ongoing miniaturization and advancements in features are set to drive further innovations, transforming how we live, work, and communicate in the digital age.

XV. COMPUTATIONAL NANOTECHNOLOGY

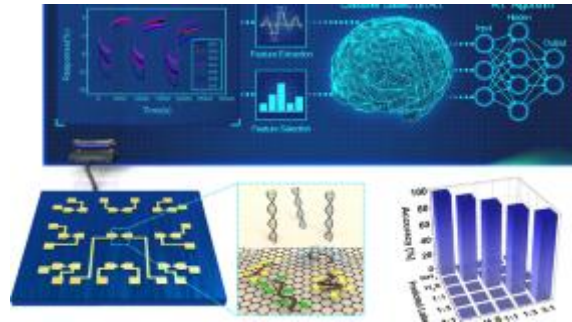

Computational nanotechnology is a branch of nanotechnology that employs computer simulations and computational methods to study and model nanoscale phenomena, materials, and devices. It plays a crucial role in advancing nanotechnology by providing insights into complex nanostructures and guiding experimental research. Computational techniques allow researchers to explore nanoscale systems in a virtual environment, predicting their behavior and properties, which is often challenging or impractical to achieve through experiments alone.

Computational nanotechnology reduces time and costs in the design, modeling, and manufacturing of nanomaterials and nanomachines. Startups are leveraging computational methods to optimize production as well as advance the circular economy. Material startups employ genetic algorithms, particle swarm optimization, and other techniques to create and analyze nanoparticle megalibraries. This speeds up the identification of nanostructures with desired properties.

1. Key Components and Techniques in Computational Nanotechnology:

- **Molecular Dynamics (MD):** Molecular dynamics simulations track the movement of atoms and molecules over time, providing valuable information about the structure, dynamics, and interactions at the atomic level.
- **Density Functional Theory (DFT):** DFT is a quantum mechanical method used to calculate electronic properties of materials. It is often applied to understand the electronic structure and properties of nanoscale materials and devices.
- **Monte Carlo Simulations:** Monte Carlo methods are used to model statistical behavior, such as thermal fluctuations and random processes, to study nanoscale systems.
- **Finite Element Analysis (FEA):** FEA is employed to simulate the behavior of nanoscale structures under mechanical, thermal, or electrical loads, helping to optimize design and functionality.
- **Quantum Monte Carlo (QMC):** QMC is a powerful method for simulating quantum systems, particularly useful for strongly correlated electron systems and materials.

2. Applications of Computational Nanotechnology:

- **Material Design and Characterization:** Computational nanotechnology helps predict the properties of nanomaterials, guiding the discovery and design of new materials with tailored properties.
- **Nanoelectronics and Devices:** Computational simulations aid in designing and optimizing nanoscale electronic devices, such as transistors, nanowires, and quantum dots.
- **Drug Design and Nanomedicine:** Computational modeling is used to study drug interactions with biological molecules and design nanoscale drug delivery systems for targeted therapies.
- **Nanocomposites and Nanomaterials:** Computational simulations provide insights into the behavior and performance of nanocomposites, enabling the design of materials with enhanced properties.
- **Nanofluidics and Nanoscale Fluid Dynamics:** Computational methods are applied to study fluid flow and transport phenomena in nanoscale channels, impacting areas like lab-on-a-chip devices and nanofluidic sensors.

3. Advantages of Computational Nanotechnology:

- **Cost and Time Efficiency:** Computational simulations can save time and resources compared to conducting extensive experimental studies.
- **Insights into Nanoscale Phenomena:** Computational tools provide detailed insights into nanoscale behavior, enabling researchers to understand complex phenomena.
- **Virtual Testing and Optimization:** Computational simulations allow for virtual testing and optimization of nanoscale systems before physical prototyping.
- **Prediction of Novel Materials and Devices:** Computational methods facilitate the discovery of new nanomaterials and the design of innovative nanodevices.

4. Challenges and Future Directions: Despite its benefits, computational nanotechnology faces challenges:

- **Complexity and Computation Time:** Some nanoscale phenomena involve a large number of particles and complex interactions, requiring significant computational resources and time.
- **Accuracy and Validity:** The accuracy of computational models relies on the underlying physical models and the quality of the input parameters.

Future directions in computational nanotechnology include:

- **Quantum Computing for Nanoscale Simulations:** The development of quantum computing could revolutionize computational methods for simulating quantum systems and materials.
 - **Machine Learning and AI Integration:** Machine learning algorithms can enhance computational models and accelerate simulations, leading to more efficient and accurate results.
5. **Multiscale Modeling:** Integrating different computational techniques to bridge different length and time scales will enable more comprehensive nanoscale simulations.

In summary, computational nanotechnology assumes a pivotal role in propelling our comprehension of nanoscale systems forward and expediting the evolution of nanotechnology. As computational methods advance further and access to high-performance computing resources persists, computational nanotechnology will persist in steering innovations across diverse domains, empowering the creation of pioneering nanomaterials and devices.

6. **Future Outlook:** Current computers are based on semiconductor logic gates which perform binary arithmetic and logical operations. However, trend of device miniaturization will reach its molecular-scale ultimate in the near future. Therefore the design and construction of molecular systems capable of performing complex logic functions is of great scientific interest now. Reduction of size is not the only advantage offered by molecular electronics .
7. **Semiconductor Nanodevices:** Semiconductor nanodevices are electronic components that harness the distinct attributes of semiconductor materials on the nanoscale. Operating with critical dimensions in the nanometer range, these devices showcase unique traits and functionalities distinct from their bulk equivalents. In numerous technological spheres, semiconductor nanodevices play a pivotal role, establishing the bedrock of contemporary electronics.

Advances in miniaturization are leading to the development of nanoscale semiconductor devices and nanorobotics. Startups utilize molecular nanotechnology (MNT) to manufacture devices and scientific instruments such as nanomanipulators and nanotransistors with high precision. Ultra-dense memory technologies, compact microprocessors, and chips in electronic circuitry enable high-performance computing in smaller form factors. Additionally, nanodevices support performance requirements in earth observation satellites, consumer electronics, electronic sensing, and autonomous vehicles. Industrial use cases of nanobots include remote monitoring and servicing in hazardous environments.

XVI. NANO-BASED TECHNOLOGY TO REPLACE SEMICONDUCTORS

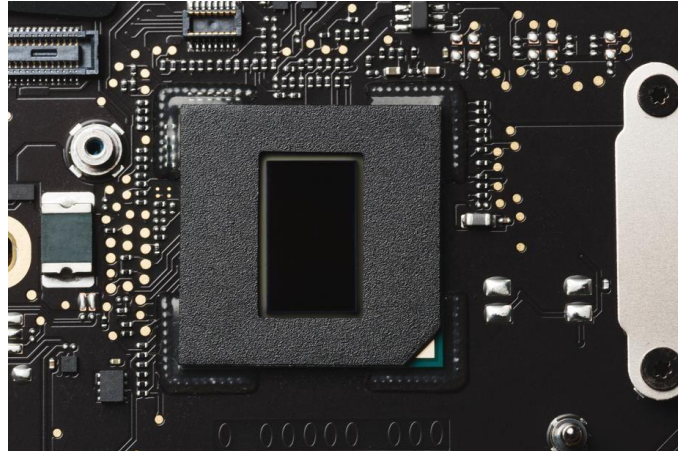

Nanotechnology was being explored as a means to enhance traditional semiconductor devices, rather than completely replace them.

Semiconductors have been the backbone of modern electronics for decades due to their ability to control the flow of electrons and facilitate the creation of transistors, which are fundamental building blocks in electronic circuits. While nanotechnology has led to advancements in semiconductor fabrication and miniaturization, replacing semiconductors entirely with nanotechnology-based devices is not yet a practical reality.

However, some specific nanomaterials, such as carbon nanotubes and graphene, have been researched as potential alternatives to conventional silicon transistors. These materials possess unique electrical properties that could lead to more efficient and faster electronic components.

- 1. Carbon nanotubes:** Carbon nanotubes (CNTs) are cylindrical nanostructures composed of carbon atoms arranged in a hexagonal lattice. They are one of the most intriguing and versatile nanomaterials discovered to date, with exceptional mechanical, electrical, thermal, and optical properties. Carbon nanotubes have garnered significant interest from researchers and industries due to their unique characteristics and potential applications in various fields. These are cylindrical structures made of carbon atoms and have remarkable electrical and mechanical properties. Researchers have been investigating their use as replacements for silicon transistors. Carbon nanotubes have the potential to create smaller, faster, and more energy-efficient devices.
- 2. Graphene:** Graphene is a two-dimensional material composed of a single layer of carbon atoms arranged in a hexagonal lattice. It is the basic building block of other carbon allotropes, such as graphite, carbon nanotubes, and fullerenes. Graphene's unique structure and exceptional properties have garnered significant interest from scientists and researchers across various disciplines, making it one of the most promising nanomaterials discovered to date. Graphene is a single layer of carbon atoms arranged in a 2D honeycomb lattice. It exhibits excellent electrical conductivity and has shown promise in various electronic applications. Graphene-based transistors might be suitable for future electronics due to their exceptional carrier mobility.

- 3. Other nanomaterials:** Apart from carbon-based nanomaterials, researchers have been exploring other novel nanomaterials and nanoscale devices, such as nanowires and quantum dots, to enhance electronic performance.

Despite these exciting developments, challenges remain in integrating nanoscale devices into large-scale semiconductor manufacturing processes. Theoretical advancements and proof-of-concept demonstrations have shown potential, but the technology is still in the research and development stage.

It's crucial to consult up-to-date sources and scientific journals for the latest advancements in nanotechnology and its potential applications in replacing or enhancing semiconductor technology. As technology progresses, new breakthroughs might occur, and the landscape could change significantly.

XVII. NANO-BASED TECHNOLOGY TO REPLACE BY RFID



RFID is a widely used technology for tracking and identifying objects using radio waves. It has found applications in various industries, including supply chain management, logistics, retail, and access control. nanotechnology can complement and enhance RFID technology, offering improvements in performance, sensitivity, and functionality

However, nanotechnology has the potential to enhance and improve RFID systems, making them more efficient and effective. Some ways nanotechnology can contribute to RFID technology include:

- 1. Smaller and More Efficient Tags:** Nanomaterials can be used to create smaller RFID tags with higher sensitivity and better performance. Nanoscale antennas and conductive materials can enable miniaturization and improve the overall efficiency of the RFID tags.
- 2. Sensing and Data Storage:** Nanoscale sensors could be integrated into RFID tags to enable additional functionalities, such as environmental monitoring or detecting specific conditions related to the tagged item. Furthermore, nanotechnology may play a role in increasing the data storage capacity of RFID tags.

- 3. Improved Read Range:** Nanotechnology can help enhance the read range of RFID systems by optimizing the properties of materials used in the tags and readers. This improvement would lead to better coverage and more robust tracking capabilities.
- 4. Energy Harvesting:** Nanotechnology can be employed to develop energy-harvesting mechanisms within RFID tags. This would enable the tags to generate power from their environment, reducing or eliminating the need for batteries and extending their lifespan.
- 5. Security and Authentication:** Nanotechnology could be used to implement advanced encryption and authentication features into RFID systems, making them more secure against potential attacks and unauthorized access.

While these are potential applications of nanotechnology in RFID, it's important to note that technologies evolve rapidly, and developments may have occurred beyond my last update. Therefore, I recommend checking more recent sources and academic publications for the latest advancements in nanotechnology and its impact on RFID systems.

XVIII. CONCLUSION

Nanotechnology, the science and engineering of manipulating matter at the nanoscale, has emerged as a transformative field with profound implications across numerous industries and scientific disciplines. Over the years, researchers and engineers have made remarkable strides in harnessing the unique properties of nanomaterials and nanodevices, leading to advancements that were once thought to be the realm of science fiction. As we conclude our exploration of nanotechnology, it is evident that this burgeoning field holds immense potential to shape the future of technology, medicine, energy, and beyond.

With the use of the nano-technology the power consumed by the electronic circuit gets reduced. Since the use of nanotechnology in electronic circuit the size and the total power consumption also get reduced and this emerging technology will produce the new solution to the circuit complexity and makes circuits much compact.

By taking advantage of quantum-level properties, Molecular Nanotechnology MNT allows for unprecedented control of the material world, at the nanoscale, providing the means by which systems and materials can be built with exacting specifications and characteristics.

The use of Nanotechnology is continuously transforming daily use products, making consumer goods plentiful, inexpensive and highly durable. The medicine will take a quantum leap forward, with the use of nanotechnology. Single molecule transistor technology has got scope in chemical and biological sensing. DNA-based logic gates that could carry out calculations inside the body have been constructed for the first time. Space travel and colonization will become safe and affordable with the advances that nanotechnology is bringing in aerospace materials. With continuous use of nanotechnology, the global life styles will change radically. The nanotechnology will have a drastic impact on the human behavior and society.

- 1. Nanotechnology's Pervasive Impact:** Nanotechnology's impact is felt across diverse sectors, revolutionizing fields such as electronics, medicine, energy, materials science, environmental remediation, and more. Its applications range from nanoelectronics, quantum computing, and advanced sensors to targeted drug delivery, regenerative medicine, and pollution mitigation. Nanotechnology's far-reaching impact arises from its capacity to manipulate materials and devices on the atomic and molecular tiers, ushering in fresh opportunities for innovation and exploration.
- 2. Advancements in Nanomaterials:** Advancements in nanomaterials have been at the core of nanotechnology's success. Graphene, carbon nanotubes, quantum dots, nanoparticles, and other nanoscale structures offer exceptional properties, such as high strength, electrical conductivity, and reactivity. The utilization of these nanomaterials has facilitated the creation of innovative devices, coatings, composites, and intelligent materials, culminating in noteworthy progress across a diverse spectrum of applications.
- 3. Energy and Environmental Applications:** Addressing global energy and environmental challenges, nanotechnology offers sustainable solutions. Nanomaterials in solar cells and energy storage devices enhance efficiency and enable renewable energy adoption. Nanocatalysts and nanosorbents improve pollutant removal and water treatment processes. Nanotechnology's role in energy conservation and environmental remediation underscores its potential to create a greener and more sustainable world.
- 4. Challenges and Ethical Considerations:** While nanotechnology holds great promise, it also presents challenges and ethical considerations. Ensuring the safe handling of nanomaterials, understanding potential health risks, and addressing environmental impacts are critical aspects that demand further investigation. Responsible research and development, along with robust regulatory frameworks, are essential to harnessing the full potential of nanotechnology while safeguarding human health and the environment.
- 5. Interdisciplinary Collaboration:** Nanotechnology thrives on interdisciplinary collaboration, bringing together experts from physics, chemistry, biology, engineering, and other fields. The convergence of diverse knowledge streams is essential for driving innovation and solving complex challenges. The cross-fertilization of ideas and expertise has facilitated groundbreaking discoveries and the seamless integration of nanotechnology into various industries.
- 6. Public Awareness and Education:** As nanotechnology continues to evolve, raising public awareness and promoting education about nanotechnology's benefits and risks are vital. Transparent communication about nanotechnology's applications, potential impact, and safety measures fosters informed decision-making and shapes responsible policies.

REFERENCES

- [1] A123 (2006). [<http://www.evworld.com/view.cfm?section=article&storyid=979>] and [<http://www.a123systems.com/html/home.html>] Appell D. (2002). Wired for success. *Nature* 419 (10 October): 553-555. Ball P. (2003). Nano lasers grown like snowflakes. *Nature materials*. 4 April 2003.
- [2] [<http://www.nature.com/materials/nanozone/news/030403/portal/030331-9.html>]. Bohr M.T. (2002). Nanotechnology goals and challenges for electronic applications. *IEEE Transactions on Nanotechnology* 1 (1): 56-62. Bottini M., Bruckner S., Nika K., Bottini N., Bellucci S., Magrini A., Bergamaschi A. and Mustelin T. (2006). Multi-wall carbon nanotubes induce T lymphocyte apoptosis. *Toxicological Letters* 160: 121-126. Braydich-Stolle L., Hussain S., Schlagger J.J. and Hofman M.C. (2005). In vitro cytotoxicity of nanoparticles in mammalian germline stem cells. *Toxicological Sciences* 88 (2): 412-419. Burgess D. (2006). ZnO nanowire LEDs have UV output. *Photonics Spectra*: January 2006: 135- 136. Carbon Nanotubes Monthly (2005). Energy storage and conversion based on the NanoSPRINT encyclopedia of carbon nanotubes. Number 4, December 2005.
- [3] [http://www.nanosprint.com/nanotubes/newsletter/monthly_1205/application.html]. Christen K. (2007). Antimicrobial nanomaterials meet increased regulatory scrutiny. *Environmental Science and Technology* online, January 3rd 2007.
- [4] [http://pubs.acs.org/subscribe/journals/esthag-w/2007/jan/policy/kc_epa.html]. Corso D., Crupi I., Ammendola G., Lombardo S. and Gerardi C. (2003). Programming options for nanocrystal MOS memories. *Materials Science and Engineering C* 23: 687-689. Cui D., Tian F., Ozkan C.S., Wang M. and Gao H. (2005). Effect of single wall carbon nanotubes on human HEK293 cells. *Toxicology Letters* 155: 73-85. Daewoo (2006). [<http://www.daewoo-electronics.de/eu/products/>]. Donaldson K., Stone V., Tran C.L., Kreyling W. and Borm P.J.A. (2004).
- [5] Nanotoxicology. *Occup. Environ. Med.* 61: 727-728. Dreher K.L. (2004). Health and environmental impact of nanotechnology: toxicological assessment of manufactured nanoparticles. *Toxicological Sciences* 77: 3-5. EC (2006). European Commission – Scientific Committee on Emerging and Newly Identified Health Risks (SCENIHR). Modified opinion (after public consultation) on the appropriateness of existing methodologies to assess the potential risks associated with engineered and adventitious products of nanotechnologies.
- [6] Adopted by the SCENIHR during the 10th plenary meeting of 10 March 2006 after public consultation. Eikos (2006). Eikos Invisicon carbon nanotube transparent conductive coatings win award from R&D magazine. [<http://www.eikos.com/rdmag.htm>]. Endo M., Hayashi T., Kim Y.A. and Muramatsu H. (2006). Development and application of carbon nanotubes. *Japanese Journal of Applied Physics* 45 (6A): 4883-4892. EuroAsia Semiconductor (2006). First quantum-dot display.
- [7] [<http://www.euroasiasemiconductor.com>]. European Commission (2005). Nano-dot materials shrink laser dimensions. [http://ec.europa.eu/research/industrial_technologies/articles/article_2469_en.html]. Fujitsu (2006). Quantum dot laser technology from Fujitsu Laboratories, QD laser, and University of Tokyo wins wall street journal technology innovation awards 2006 runner-up award for semiconductors. [<http://www.fujitsu.com/global/news/pr/archives/month/2006/20060911-02.html>].
- [8] Gargini P.A. (2004). Silicon nanoelectronics and beyond. *Journal of Nanoparticle Research* 6: 11-26. GRL-TN-09-2007 20 Greenpeace Environmental Trust (2003). Future technologies, today's choices. ISBN 1-903907-05-5. Grodzik M. and Sawosz E. (2006).
- [9] The influence of silver nanoparticles on chicken embryo development and bursa of Fabricius morphology. *Journal of Animal and Feed Sciences* 15 (Suppl 1): 111-114. Gröning P. (2005). Nanotechnology: an approach to mimic natural architectures and concepts. *Advanced Engineering Materials* 7 (5): 279-291. Hardman R. (2006).
- [10] A toxicologic review of quantum dots: toxicity depends on physiochemical and environmental factors. *Environmental Health Perspectives* 114 (2): 165-172. Hood E. (2004).
- [11] Nanotechnology: looking as we leap. *Environmental Health Perspectives* 112 (13): A741-A749. Hussain S.M., Hess K.L., Gearhart J.M., Geiss K.T. and Schlager J.J. (2005). In vitro toxicity of nanoparticles in BRL 3A rat liver cells. *Toxicology in Vitro* 19: 975-983. Hussain S.M., Javorina A.K., Schrand A.M., Duhart H.M., Ali S.F. and Schlager J.J. (2006).
- [12] The interaction of manganese nanoparticles with PC-12 cells induces dopamine depletion. *Toxicological Sciences* 92 (2): 445-463. IBM (2006). Totally tubular! IBM researchers put integrated circuit on nanotube. [http://www.ibm.com/news/us/en/2006/03/2006_03_24.html]. iNEMI (2005).
- [13] International Electronics Manufacturing Initiative. Pb-Free Nano-Solder Project. [http://www.nemi.org/cms/projects/ba/Pb-free_nano-solder.html]. iNEMI (2006).

- [14] [http://209.85.135.104/search?q=cache:O6mow_laTfgJ:thor.inemi.org/webdownload/projects/ba/Warm_Assembly/Mechanical_Assembly_SOW_Draft_V1-1.pdf+mechanically+adhesive+nano-hooks&hl=en&gl=uk&ct=clnk&cd=2]. Intel (2006). 65-nanometer technology.
- [15] [http://www.intel.com/technology/silicon/65nm_technology.htm]. Isakovic A., Markovic Z., Todorovic-Markovic B., Nikolic N., Vranjes-Djuric S., Mirkovic M., Dramicanin M., Harhaji L., Raicevic N., Nikolic Z. and Trajkovic V. (2006). Distinct cytotoxic mechanisms of pristine versus hydroxylated fullerene.
- [16] *Toxicological Sciences* 91 (1): 173-183. Jia G., Wang H., Yan L., Wang X., Pei R., Yan T., Zhao Y. and Guo X. (2005). Cytotoxicity of carbon nanomaterials: single-wall nanotube, multi-wall nanotube, and fullerene. *Environmental Science and Toxicology* 39 (5): 1378-1383. Jortner J. and Rao C.N.R. (2002). Nanostructured advanced materials. Perspectives and directions. *Pure Appl. Chem.* 74 (9): 1491-1506. Kunellos M. (2006). Intel researches nanotubes for chip designs.
- [17] [<http://news.zdnet.co.uk/emergingtech/0,1000000183,39284679,00.htm>]. Lam C-W., James J.T., McCluskey R. and Hunter R.L. (2004). Pulmonary toxicity of single-wall carbon nanotubes in mice 7 and 90 days after intratracheal instillation. *Toxicological Sciences* 77: 126-134. Lam C-W., James J.T., McCluskey R., Arepalli S. and Hunter R.L. (2006). A review of carbon nanotube toxicity and assessment of potential occupational and environmental health risks. *Critical Reviews in Toxicology* 36: 189-217. Liu Y., Tang S. and Banerjee S.K. (2006).
- [18] Tunnel oxide thickness dependence of activation energy for retention time in SiGe quantum dot flash memory. *Applied Physics Letters* 88, 213504. Maruccio G., Cingolani R. and Rinaldi R. (2004). Projecting the nanoworld: concepts, results and perspectives of molecular electronics. *J. Mater. Chem* 14: 542-554. Matsui I. (2005). Nanoparticles for electronic device applications: a brief review.
- [19] *Journal of Chemical Engineering of Japan* 38 (8): 535-546. GRL-TN-09-2007 21 Maynard A.D. (2006). Safe handling of nanotechnology. *Nature* 444 (16 November): 267-269. Maynard A.D. and Kuempel E.D. (2005). Airborne nanostructured particles and occupational health. *Journal of Nanoparticle Research* 7: 587-614. Monteiro-Riviere N.A., Nemanich R.J., Inman A.O., Wang Y.Y. and Riviere J.E. (2005). Multiwalled carbon nanotube interactions with human epidermal keratinocytes. *Toxicology Letters* 155: 377-384. Morones J.R., Elechiguerra J.L., Camacho A., Holt K., Kouri J.B., Ramirez J.T. and Yacaman M.J. (2005). The bactericidal effect of silver nanoparticles. *Nanotechnology* 16: 2346- 2353. Motorola (2005). Nanotechnology for communications.
- [20] [http://www.motorola.com/mot/doc/6/6445_MotDoc.pdf]. Nanofilm (2006). [<http://www.nanofilmtechnology.com/nanotechnology/index.htm>]. NanoHorizons (2006). Press release: NanoHorizons signs exclusive licensing agreement with Solarity for breakthrough solar cell technology [<http://www.nanohorizons.com/PR08012006.shtml>]. Nanotech Plc (2006). What is nanotechnology and nano-silver? [<http://www.jrnanotech.com>].
- [21] Nantero (2006a). Press release: Nantero announces routine use of nanotubes in production CMOS fabs . Carbon nanotube electronics era has begun. [http://www.nantero.com/pdf/Press_Release_11_06%20.pdf]. Nantero (2006b). NRAMTM. [<http://www.nantero.com/mission.html>]. Nel A., Xia T., Mädler L. and Li N. (2006). Toxic potential of materials at the nanolevel. *Science* 311 (3 February): 622-627. Norel (2005). OLED: the next generation FPD and lighting technology.
- [22] [<http://www.noreloptronics.com/technology.html>]. Oberdörster E. (2004). Manufactured nanomaterials (fullerenes, C60) induce oxidative stress in the brain of juvenile largemouth bass. *Environmental Health Perspectives* 112 (10): 1058- 1062. Oberdörster E., Zhu S., Blickey T.M., McClellan-Green P. and Haasch M.L. (2006). Ecotoxicology of carbon-based engineered nanoparticles: effects of fullerene (C60) on aquatic organisms. *Carbon* 44: 1112-1120. Oberdörster G., Maynard A., Donaldson K., Castranova V., Fitzpatrick J., Ausman K., Carter J., Karn B., Kreyling W., Lai D., Olin S., Monteiro-Riviere N., Warheit D. and Yang H. (2005b). Principles for characterizing the potential human health effects from exposure to nanomaterials: elements of a screening strategy. *Particle and Fibre Toxicology* 2:8 (6 October 2005). Oberdörster G., Oberdörster E. and Oberdörster J. (2005).
- [23] Nanotoxicology: an emerging discipline evolving from studies of ultrafine particles. *Environmental Health Perspectives* 113 (7): 823-839. Office of Technology Transfer and Enterprise Development (2006). Quantum dots for white LEDs. An emerging lighting system from the Rosenthal Group and Vanderbilt University. Confidential Executive Summary. September 2006.
- [24] [http://www.vanderbilt.edu/technology_transfer/siteadmin/tech/docs/SSL_Executive_Summary_final_FL_2.pdf]. Photonics Spectra (2006). Nanoelectronics materials and equipment market to grow. *Photonics Spectra* (January 2006): 96-97. Porter A.E., Muller K., Skepper J., Midgley P. and Welland M. (2006). Uptake of C60 by human monocyte macrophages, its localization and implications for toxicity: studied by high resolution electron microscopy and electron tomography. *Acta Biomaterialia* 2: 409-419. GRL-TN-09-2007 22 Rouse J.G., Yang J., Barron A.R. and Monteiro-Riviere N.A. (2006).

- Fullerene-based amino acid nanoparticles interactions with human epidermal keratinocytes. *Toxicology in Vitro* 20: 1313-1320. Royal Society (2004).
- [25] Nanoscience and nanotechnologies: opportunities and uncertainties. Samsung (2006). [<http://www.nanotec.org.uk/finalReport.htm>]. Service R.F. (2005). EPA ponders voluntary nanotechnology regulations. *Science* 309 (1 July): 36. Simonite T. (2006). Paint-on laser brings optical computing closer. *New Scientist.com* news service. 19 April 2006. [<http://www.newscientisttech.com/article.ns?id=dn9017&print=true>]. Toshiba (2005). Toshiba's new rechargeable lithium-ion battery recharges in only one minute. [http://www.toshiba.co.jp/about/press/2005_03/pr2901.htm].
- [26] Walters, A., Santillo, D., Labunska, I. & Brigden, K. (2006) Background documents on three key elements of the electronics manufacturing sector: semiconductors, printed wiring (circuit) boards and TFT-LCD screens. Greenpeace Research Laboratories Technical Note 08/2006; www.greenpeace.to/publications. Warheit D.B., Laurence B.R., Reed K.L., Roach D.H., Reynolds G.A.M. and Webb T.R. (2004). Comparative pulmonary toxicity assessment of single-wall carbon nanotubes in rats. *Toxicological Sciences* 77: 117-125. *Washington Post* (2006). EPA to regulate nanoproducts sold as germ-killing. [<http://www.washingtonpost.com/wpdyn/content/article/2006/11/22/AR2006112201979.html>].
- [27] Weiss P (2006). Quantum-dot leap. *Science News Online* 169 (22): 344. Whatmore R.W. (2006). Nanotechnology – what is it? Should we be worried? *Occupational Medicine – Oxford* 56 (5): 295-299. Woodrow Wilson International Centre for Scholars, Washington DC, (2006). Project on Emerging Nanotechnologies: a nanotechnology consumer products inventory. Published online at [<http://www.nanotechproject.org/consumerproducts>].