

CARBON NANOTUBES: SYNTHETIC METHODS, FUNCTIONALIZATION AND EMERGING APPLICATIONS

Abstract

Carbon nanotubes possess many remarkable and attractive properties in context to weight, strength, conductivity, sensitivity and surface area. This chapter will review the important synthetic aspects of carbon nanotube (CNT) chemistry starting from the old plasma-based methods. Synthesis of CNT utilizing electric arc discharge method will be discussed with or without catalyst. For the synthesis of highly pure and better quality single walled carbon nanotubes, the laser ablation method is economically high as it uses highly purified graphite rods and laser powers. Other important synthetic methods such as flame, chemical vapor deposition will also be discussed with emphasis on their peculiarities. The purification methods (chemical and physical) and characterization details will also be penned down in brief. Various aspects of covalent and non-covalent functionalization of the CNTs will also be elaborated. The applicability of the CNTs in the areas of electronics and energy will be summarized in detail along with the future prospects and the associated challenges.

Keywords: Characterization, functionalization, purification, sensing, supercapacitors, synthesis

Authors

Vishwas Chaudhri

Department of Chemistry
J. C. Bose University of Science and
Technology
YMCA, Faridabad, Haryana, India

Laxmi Devi

Department of Chemistry
Indira Gandhi University
Meerpur, Rewari, Haryana, India

Sidhant Yadav

Department of Chemistry
Indira Gandhi University
Meerpur, Rewari, Haryana, India

Anirban Das

Department of Chemistry
Biochemistry and Forensic Sciences
Amity School of Applied Sciences
Amity University Haryana, India

Rashmi Pundeer

Department of Chemistry
Indira Gandhi University
Meerpur, Rewari, Haryana, India

I. INTRODUCTION

Nature has blessed carbon as an abundant and renewable energy storage medium in the form of carbohydrates which is composed of carbon oxygen and hydrogen. Carbon-based materials are finding increasing applications in renewable energy production, energy conservation, water purification, biomedical uses, soil additives and gas separation, therefore, their investigation is an emerging topic in the context of sustainable material development.(Titirici et al., 2015) There were many forms of carbon known like graphite, diamond and amorphous carbon till 1980 when another form of carbon i.e. carbon nanotube (CNTs) was discovered in 1991 by S. Iijima. CNTs are carbon allotropes having a cylindrical rod like morphology with a high aspect ratio. CNT may be visualized as a seamless rolled tube of a 2D graphene sheet. The field of carbon nanotubes has become very significant because of many attractive properties such as high aspect ratio, enormous mechanical strength, good elasticity, better chemical consistency and high conductivity. (Anzar et al., 2020):(Rathinavel et al., 2021a)

“The chapter will present a detailed account on the synthetic methods for single, double, and multiple-walled CNTs (MWCNTs) including green sustainable synthetic approaches and their valuable applications in the areas of electronics, sensing (biosensing), optics, and drug delivery. CNTs prospects in gene therapy, cancer treatment, in industries will be summarized and the associated challenges will be discussed.”

II. SYNTHETIC DEVELOPMENTS FOR CARBON NANOTUBES

Many different methods have been developed for the synthesis of the CNTs possessing different morphology. (Baghel et al., 2022; Baghel & Kaushal, 2022; Bogdanova et al., 2023; Lin et al., 2023; Martínez-Iniesta et al., 2022; Saifuddin et al., 2013; Vincent et al., 2023; Zheng et al., n.d.)The synthetic methods make the use of energy in the form of arc discharge, laser or furnace to fragment the carbon source which undergo recombination to generate CNTs. Herein, we will describe the four main methods used for synthesizing CNTs namely plasma-based methods, chemical vapor deposition, flame synthesis, and vapor-phase synthesis.(Choudhary et al., 2014) The methods for the synthesis of CNTs are discussed starting from the traditional plasma based methods.

- 1. Plasma-Based Methods:** The Arc discharge as well as laser ablation methods are commonly known as plasma-based methods.
- 2. Arc Discharge Method:** Iijima, in 1991 reported the synthesis of CNTs via arc evaporation discharge method that is similar to traditional techniques used for the synthesis of fullerene.(Iijima, 1991) This method results in a high yield (>75%). The arc discharge approach uses high temperature (>1700) for the synthesis of CNTs and result in lesser structural defects in comparison with other methods. The carbon needles of, iron, or nickel that are also accumulated on cathode to serve as the catalyst.Both multi-walled carbon nanotubes (MWCNTs) and single-walled carbon nanotubes (SWCNTs) can be synthesized *via* the arc discharge method. Ando and Zhao reported that a carbon nanowire, and a fine innermost tube with a diameter smaller than 0.4nm can be synthesized *via* arc discharge process (H_2 ambient). The ambient gas role is crucial, and

pure H_2 gas is adequate for getting MWCNTs of high crystallinity. For synthesizing SWCNTs by this method, incorporation of catalytic particles in graphite anode is essential, and SWCNTs are realized in soot form, in the evaporation chamber. The Schematic diagram of an arc evaporation apparatus (vacuum chamber) for preparing CNTs is shown in **figure 1**. Two electrodes of graphite were vertically installed, with the distance between tips of the two rods being fixed in the range of 1-2 nm. An ambient gas was introduced after evacuating the chamber via a diffusion pump. On applying dc arc discharge between two graphite electrodes, the anode was depleted and the formation of fullerene takes place in the soot chamber. After that evaporated anodic carbon gets deposited on the cathode top which is named a cathode deposit. (Ando & Zhao, 2006)

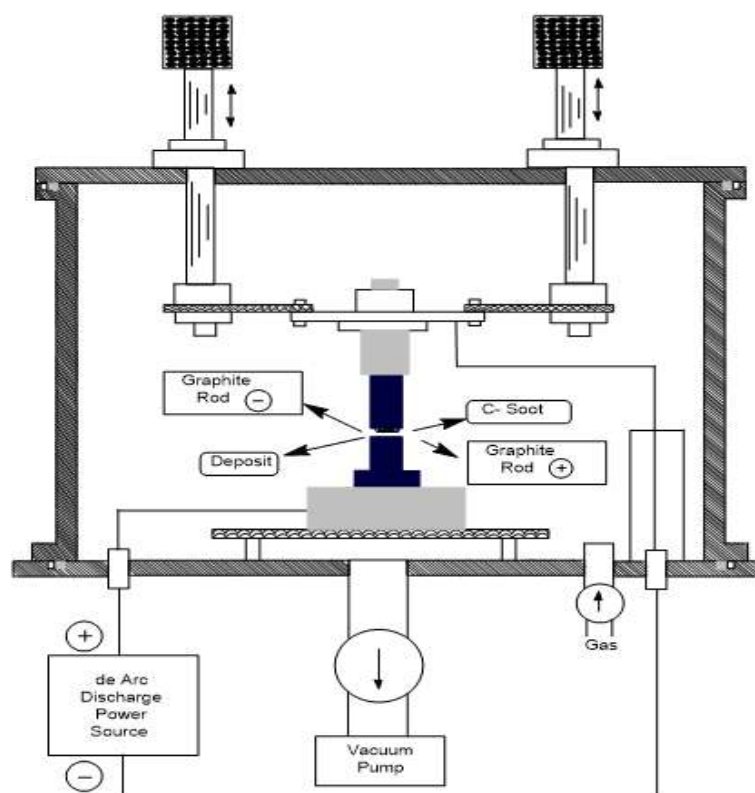

Figure 1: Arc evaporation apparatus for producing CNTs

- 3. Laser Ablation Method:** In the process of laser ablation, a graphite target is heated up to $1200^{\circ}C$ in an inert (Ar) atmosphere. Then carbon is vaporized from the corresponding target by using a beam of pulsed laser and collected on the cooled surface of copper. The target graphite also possesses little quantities of cobalt and nickel that are also vaporized and deposited on the surface of Cu and catalyzes the nucleation of CNTs. The laser ablation method yields relatively long and wide nanotubes. The tubes are usually formed in twisted or bundled ropes along with incredibly uniform diameter distribution. The growth of CNTs is considered to happen via scooter mechanism, where a single atom of catalyst scoots or travels around an open tube end, absorbing carbon (C) from Ar atmosphere and feeding this carbon within graphene sheet. After saturation of open end with the catalyst atoms, the growth of tubes is terminated, at that point, this separates from tube, and a fullerene cap is allowed to form. (Kelsall et al., 2005) The properties

such as structural and the chemical composition of target materials gets affected by this method. The SWCNTs produced in the laser ablation method have better quality as well as better purity. (Rathinavel et al., 2021b)

In 1996, Thess, *et al* produced fullerene SWCNTs via laser vaporization of a mixture of carbon (C)-nickel (Ni)-cobalt (Co) at temperature 1200°C, resulting in greater than 70 percent yield. In the production of two-dimensional SWCNTs crystalline ropes may be realized as a consequence of the collisions between the developing tubelets in gas phase, although they are adequately short for their alignment with van der Waals forces without being tangled. (Thess et al., 1996)

- 4. Chemical Vapor Deposition (CVD):** Nowadays, CVD is an attractive method for the production of CNTs. In this method, the thermal decomposition of the vapor of hydrocarbon is realized in presence of a catalyst. Hence, this method is also known as catalytic CVD and thermal CVD. The schematic diagram of the simplest form of CVD setup for the growth of CNT is shown in **Figure 2**

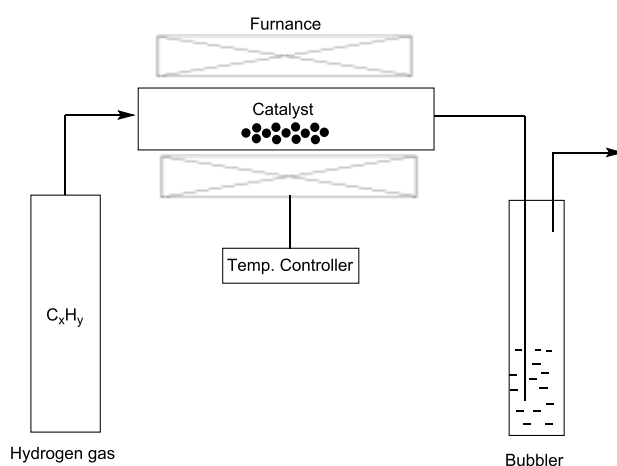

Figure 2: The Schematic diagram of the CVD experimental setup

In this process, the vapors of hydrocarbons are passed (usually for 15–60 min) through the tubular reactor, where catalyst material is available for decomposition of hydrocarbon at adequately high temperature (typically 600–1200°C). In the reactor, the CNTs grow on a catalyst and are then collected on cooling to room temperature (R.T.).

If a liquid hydrocarbon (alcohol, benzene, etc.) is to be utilized as CNT precursors, the liquid should be heated in a flask and then inert gas should be purged through it, which brings the vapor of hydrocarbon to the reaction zone. In the case of use of solid hydrocarbons, as the precursors of CNT, it can be placed directly into the zone of low-temperature in the reaction tube. In CVD, catalyst precursors can be utilized in solid, liquid, or gaseous form, and may either be fed from the outside or be properly placed inside the reactor. According to the most widely accepted general growth mechanism of CNT, when hydrocarbon vapor reaches metal nanoparticles, they decompose into hydrogen and carbon species; carbon dissolves within the metal, and hydrogen is released. The dissolved carbon gets precipitated out after attaining the limit of carbon

solubility at that particular temperature and crystallizes in a cylindrical structure bearing no dangling bonds, therefore being energetically stable. The formation of SWCNT or MWCNT is governed by the particle size of the catalyst. A few nanometers (nm) particle size favors the formation of SWCNT, whereas if the particle size is a few tens nm, MWCNT forms. The synthesis of CNTs is governed by many parameters like temperature, pressure, deposition time, gas-flow rate, reactor geometry, hydrocarbon, catalyst, etc. The most frequently used precursors for CNT are ethylene, methane, carbon monoxide, acetylene, benzene, and xylene. (Kumar & Ando, 2010) Dai *et al* had first synthesized SWCNTs from the disproportionation of the carbon monoxide (CO) in presence of Mo NPs at 1200 °C. (Dai *et al.*, 1996) In 2002, synthesis of highly pure SWCNTs were reported by Maruyama *et al* from the alcohol (ethanol) on Fe-Co-saturated zeolite support *via* a low-temperature technique. (Maruyama *et al.*, 2002) In 2004, Hata *et al.* has reported the water-assisted synthesis of pure SWCNTs on the substrates of silicon by utilizing ethylene CVD [9]. (Hata *et al.*, 2004) Jose Yacaman *et al.* obtained crystal clear helical MWCNTs from the acetylene at 700°C. (José- Yacamán *et al.*, 1993)

Metal particles of nanometer size are needed in the synthesis of CNTs to enable the decomposition of hydrocarbon at a much lower temperature as compared to spontaneous hydrocarbon decomposition temperature. Fe, Ni, Co are commonly used metals because of the high solubility and high diffusivity of carbon in them. Apart from Fe, Ni, Co transition metals, other metals like Au, Cu, Ag, Pd, Pt were also realized to catalyze several hydrocarbons for the growth of CNTs. Ferrocene, nickelocene, cobaltocene too are widely used CNT catalysts, since they release metal NPs *in-situ* for the effective decomposition of hydrocarbon. (Kumar & Ando, 2010)

- 5. Plasma Enhanced Chemical Vapor Deposition (PECVD):** PECVD has been reported to be superior to CVD, in controlling the growth mechanism of CNTs and reducing the temperature needed for synthesis of CNT. Recently this method has been studied for the production of vertically-aligned carbon nanotubes. PECVD is used for synthesis of field emitters, which are considered useful in flat panel displays. By highly energetic electrons, the precursor gets dissociated, consequently, the temperature of the substrate can be reduced substantially as compared to thermal CVD. (Awasthi *et al.*, 2005) Two basic requirements for PECVD are (i) catalyst NPs should be prepared in such a way that coagulation doesn't occur and catalytic function is maintained during PECVD (ii) utilization of the plasma should be regulated so as to prevent ion damage to either growing SWCNTs or to the catalyst NPs. The phenomenal advantage of PECVD is the synthesis of discrete vertically aligned carbon nanotubes (VA-CNTs) under an electric field that is normal to the substrate. This feature makes it extremely desirable for nanoelectronics device-fabrication like interconnects, field emission, and scanning nanoprobes devices due to the fabrication of VA-CNTs on the patterned substrates at somewhat reduced temperatures in comparison with thermal CVD.

The direct exposure of the substrates to energetic ions can be avoided if substrates were placed at a lesser distance from the master plasma region inside plasma chamber. The bombardment of ions destroys nanostructured zeolite if the substrates are exposed directly to plasma and just MWCNTs are synthesized in tip growth system from the rough surface of the zeolite. (Kato *et al.*, 2004) T. Nozaki *et al.* proposed the atmospheric pressure radio-frequency discharge (APRFD) and atmospheric pressure-PECVD (AP-

PECVD) for VA-SWCNTs. In APRFD, the substrates are exposed directly to cathodic sheath wherein substantial potential drop occurs. Because of the large collision frequency between particles, ion damage in atmospheric pressure conditions is inevitable. Both the large electric fields and small ion damage are used together in AP-PECVD for synthesizing utmost-purity VA-SWCNTs. The schematic diagram of the APRFD reactor for producing SWCNT is illustrated in **figure 3**. APRFD apparatus was built across two parallel metallic electrodes having diameters 4 cm separated by 5 mm. A 13.56 MHz radio-frequency power source was coupled with an upper electrode. Substrates were placed on the hot surface of the bottom electrode. After evacuating the chamber to 1.3 kPa, hydrogen and helium gases were brought from upper electrode that was equipped with a showerhead having a pinhole of 20×1 mm. The reacted gas leaves from the check valve fitted on top of chamber, leaving 108 kPa pressure on the inside of the chamber. The catalyst nanoparticles (NPs) were reduced in He/H₂ APRFD at temperature 400°C for 5 minutes. The temperature of the substrate at that time raised to 700°C within 15 minutes and methane (CH₄) was added for the deposition of CNTs. (Nozaki et al., 2007)

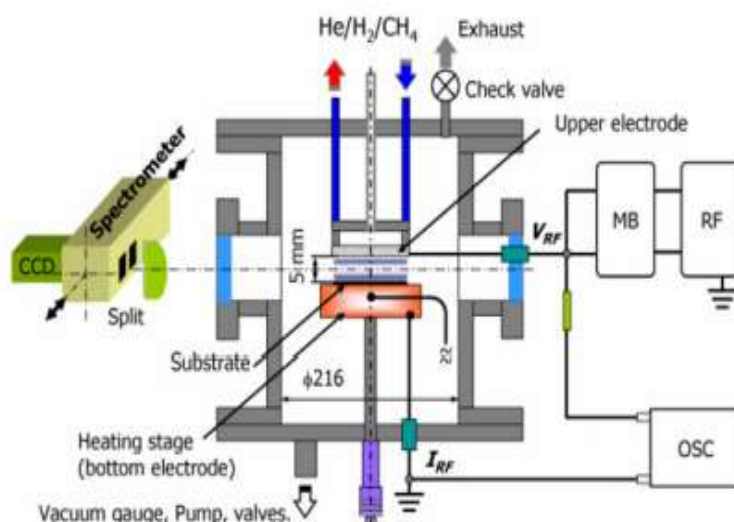

Figure 3: Measurement system and reactor of APRFD. Reprinted with permission from Nozaki, T., Ohnishi, K., Okazaki, K. & Kortshagen, U. Fabrication of vertically aligned single-walled carbon nanotubes in atmospheric pressure non-thermal plasma CVD. *Carbon N. Y.* 45, 364–374 (2007). Copyright (2007) Elsevier Ltd.

- 6. Flame Synthesis:** The flame synthesis process is auto-thermal that efficiently imparts optimal temperature for attaining desirable conditions for the synthesis of CNTs. An extraordinary combination of catalytic factors and chemicals is provided by hydrocarbon flames that are favorable for the initiation as well as the growth of CNTs. The gases CH₄, CO, C₂H₂, C₂H₄, C₂H₆, which exist in post-flame atmosphere form a diversified source of gaseous carbon. In the flames, chemical energy liberated in form of heat, reinforces carbon deposition endothermic reactions. The necessary reaction sites for solid carbon deposition are provided by the metal catalysts (aerosol or substrate). The geometry, as well as characteristics of catalysts, contribute crucially to the structural properties of CNTs. Flames are commercially utilized for solid carbon production like printing ink and carbon black. The ideal environment for CNTs growth on a huge commercial scale can be

provided by properly tuned flame conditions. Flame is a remarkable medium for CNTs synthesis as it provides both the chemical species and energy. In the flame, Hydrocarbon fuel such as methane, ethylene, and acetylene react with an oxidizer (O_2) to form unique products (in gas phase) that include water vapor, hydrogen, carbon dioxide, carbon monoxide, radicals, saturated hydrocarbons, and unsaturated hydrocarbons. The source of the solid carbon that is deposited on catalyst in the formation of carbon nanostructures is a mixture of gaseous precursors (carbon monoxide and hydrocarbons). The structure of SWCNTs and MWCNTs depends on the rate of carbon deposition and the size of the catalyst particle. In flame synthesis, the key parameters for CNTs growth are gas-phase chemistry of post flame, the type and structure of the catalyst, and temperature at the catalyst particle surface. (Gore & Sane, 2011)

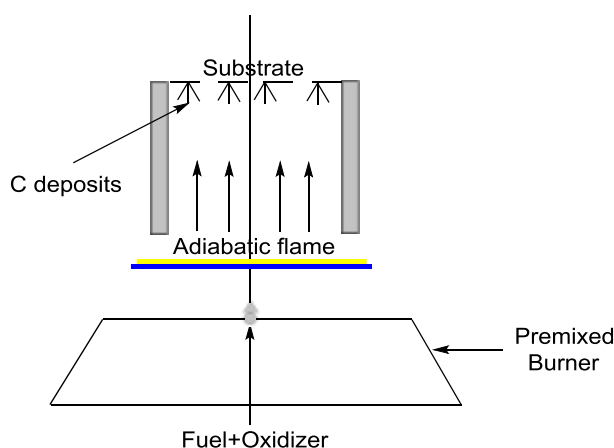

Figure 4: Schematic representation of hydrocarbon flames method for synthesis of CNTs

The flame consists of more intermediate radicals produced during acute gas-phase reactions (homogeneous reactions) than in CVD. The flame configuration is crucial for fluid dynamics establishment, mass and energy transfer, as well as flame chemistry. Flames are mainly classified as premixed, partially premixed, and diffusion or non-premixed. All the mentioned configurations of flame have been utilized for the growth of CNTs. In premixed flame, the fuel and oxidizer are mixed effectively before burning (for example in a Bunsen flame). In the co-flow jet burner, the diffusion flame is produced when fuel is provided from the inner tube, an oxidizer is introduced from the outer tube and the inverse diffusion flame is established when the oxidizer and fuel are inverted. In the experiments of flame synthesis, Ar and N_2 are used as diluents and laminar flames that are produced because of their uniform structure have been utilized for the synthesis of CNTs. Typically, metal catalysts Fe, Co, Ni, have been used. In the substrate method the substrate is coated with a layer of catalyst positioned at a suitable place in the inside of the flame. Because of the interaction between flame and substrate, the catalyst NPs are produced at the substrate. Stationary substrates due to the bigger size of catalyst NPs are usually used in MWCNT synthesis. Catalysts in vapor aerosol form can be introduced inside the flame. Metallocenes and transition-metal nitrates have been typically used in the process of flame synthesis. Because of catalyst vapor condensation, the catalyst particles having size around 5nm are produced that are appropriate for SWCNTs growth. An extensive study on the synthesis of MWCNT in the premixed flames was carried out by Vander Waal *et al.* (Gore & Sane, 2011) Carbon-containing

gaseous phase species are further investigated by Gopinath and Gore for carbon deposition during MWCNTs synthesis.(Gopinath & Gore, 2007)

Height *et al.* investigated the impact of the operating conditions on nanotubes structure and transitional requirements between CNT formation and soot formation. The SWCNTs growth mechanism has been discovered analogous to the mechanism of solid carbon forms such as soot. It is well known that precursors of soot are polyaromatic hydrocarbons that are created *via* the decomposition of acetylene. The earlier abundance of C-species can poison the catalyst particle and inhibit the earlier inception of CNT in the flame.(Height et al., 2004)

- 7. Vapor-Phase Synthesis:** The vapor phase growth method is a modified and advanced form of the CVD method. From the application point of view, low cost, high-yield, high-purity, and large-scale manufacturing are important, and consequently, this method has been investigated intensively. C.J. Lee *et al* reported the synthesis of highly pure CNTs at a large scale, utilizing the catalytic reaction of mixtures of C_2H_2 and $Fe(CO)_5$ at temperature $750-950^\circ C$. The carrier gas Ar is supplied at a higher flow rate (2000 to 3000 sccm) to get the large productivity of the CNTs employing a one furnace system in the absence of a water-cooling injector. The vapor phase growth system consists of a 200 mm heating zone and a furnace (horizontal quartz tube) with 20 mm inner diameter as illustrated in **Figure 5**. The synthesis of CNTs is done by supplying the source of catalyst ($Fe(CO)_5$), carrier gas (Ar), and the reaction gas C_2H_2 within a quartz tube. Liquid $Fe(CO)_5$ (kept at R.T. in bubbler) was injected into reactor by directly bubbling C_2H_2 gas or Ar gas with flow rates of 30 sccm, and 300 sccm respectively. Catalyst source and gases were introduced directly into furnace at $750-950^\circ C$ for about 30 minutes. After completion of the reaction, the furnace is cooled down to R.T. by flowing Ar gas at a flow rate of 500 sccm. SEM image of CNTs synthesized by direct bubbling of C_2H_2 at $950^\circ C$ is shown in **Figure 6**. The Argon (Ar) carrier gas and C_2H_2 gas were flowed at 2000 sccm and 30 sccm, respectively.(Lee et al., 2002)

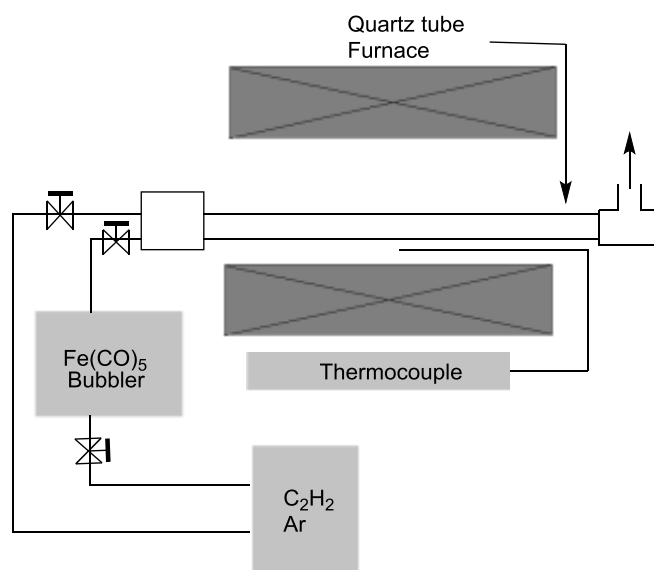

Figure 5: Schematic diagram for the vapor phase growth system.

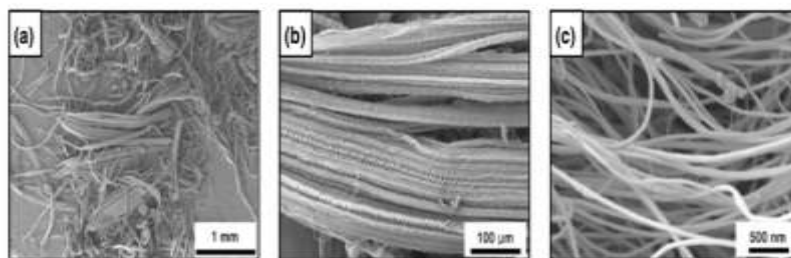
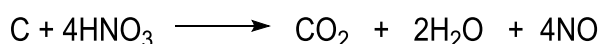

Figure 6: SEM image of the CNTs produced via direct bubbling of C₂H₂ (flow rate- 30 sccm). (a) SEM micrograph of CNTs (length is nearly 2000 μm). (b) Magnified micrograph of (a). (c) Magnified micrograph of (b) exhibiting average diameter (80-90 nm). Reprinted with permission from Lee, C. J., Lyu, S. C., Kim, H.-W., Park, C.-Y. & Yang, C.-W. Large-scale production of aligned carbon nanotubes by the vapor phase growth method. *Chem. Phys. Lett.* 359, 109–114 (2002). Copyright (2002) Elsevier Science B.V.

III. PURIFICATION AND CHARACTERIZATION

Purification of Carbon nanotubes is required after synthesis to remove the unwanted entities such as carbon nanoparticles, amorphous carbon, residual catalyst and other graphitic impurities. Mild purification methods are preferred to get the pure CNTs. Both chemical and physical purification techniques are applied for the removal of impurities.

- 1. Chemical Purification:** Chemical purification is mainly carried out by oxidation of the synthesized CNTs. A selective oxidation process is able to remove amorphous carbon and carbon particles more easily because of their higher oxidation response rate. The oxidative ability of amorphous carbon is high due to the presence of hanging bonds while in CNTs, pentagonal carbon-rings tips are more prone to oxidation than the hexagonal carbon-rings of the cylindrical tube. Oxidation of CNTs can be done under both wet and dry conditions. Under wet conditions, the oxidation is facilitated by concentrated acids or strong oxidants while dry oxidation can be performed by air, oxygen or other gases at controlled temperature.
- 2. Liquid Phase Oxidation:** offers the most homogeneous and simplified oxidations in CNT with high efficiency. Liquid phase oxidation is always accompanied with the surface modification of carbon nanotubes and oxygenated functional groups are introduced on the sidewall and ends of the nanotubes. Mineral acid is probably the most employed treatment, particularly for carbon impurity and metal particles. Removal of catalyst particles from the CNTs depends on the duration and temperature of reflux. Researchers have reported that if nitric acid is used for refluxing treatment for 30 minutes, the metal particles get dissolved without causing significant structural damages, though tips are opened without any defect. (Delpeux et al., 2005; Mohanapriya & Lakshminarayanan, 2007) It is also found that prolonged purification process by nitric acid causes reaction at defect sites thus unzipping the tube walls of CNTs which results in increase in interlayer spacing of the tube.



In addition to mineral acids, other liquid oxidizing agents such as hydrogen peroxide (H_2O_2) and potassium permanganate (KMnO_4) can also be used for carbon nanotubes' purification because of sufficiently high oxidation potential of metal cations. (Rasheed et al., 2007) Transmission electron microscopy (TEM) images of pure CNT's have indicated the removal of all aggregates of amorphous carbon and opening of tips.



However, it is relevant to mention that extra steps are required to extract the MnO_2 . Hydrogen peroxide can also be used for purification, as in this purification, water is formed and lower impurities are found in the purified product.

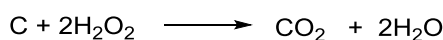

Oxidation of single walled carbon nanotubes by hydrogen peroxide using iron particles as catalyst resulted in the successful elimination of large quantities of amorphous carbon.

Alkalis have also been used for the purification of carbon nanotubes. Raymundo-Pinero and coworkers used sodium hydroxide and multiwalled carbon nanotubes in the 3:1 at 700 °C. (Raymundo-Pinero et al., 2005) As metallic sodium can intercalate only to disordered carbonaceous impurities, leaving the well-organized structure, therefore, it was found that nano tubular morphology was not affected and amorphous carbon, catalyst support and catalyst material particles were removed with the opening of the tubes.

Reports are available in literature showing the use of mixed oxidants for carbon nanotubes purification in order to get enhanced oxidative effect. Salernitano *et al* have compared the purification results on CNTs by using nitric acid and nitric acid-hydrochloric acid mixture in a ratio of 3:1. Synergy effect was found in case of HNO_3 -HCl oxidant, implying that HNO_3 dissolved the metal particles while HCl was responsible for eventual removal of the metal oxides. (Salernitano et al., 2007)

Piranha solution (4:1 v/v 96% H_2SO_4 /30% H_2O_2) has been used at high and low temperature for oxidative cutting of carbon nanotubes. (Ziegler et al., 2005) At high temperature, the oxidation solution attacked the existed defect sites and consumed the oxidized opening to cut the carbon nanotubes which bought about the etching of small-diameter CNTs while at low temperature, minimal carbon loss and slow etch rate was observed, resulting in the preservation of original diameter distribution. By using Piranha oxidant at low temperature, only the existed damage sites were attacked. The mixed acids H_2SO_4 - HNO_3 (4:1 v/v) were also used for the purification of CNTs. The mixture of oxidants gave a lot of broken SWCNTs which are opened. (Zhang et al., 2000)

Microwave digestion technique has been successfully used by some research groups for the purification of carbon nanotubes to eliminate amorphous carbon and the emergent embedded catalyst at reduced time period. The microwave method can also be applied just by using 20% H_2O_2 without acid. (Chen et al., 2005)

Gas phase oxidation can be considered milder and a more advantageous method over liquid phase oxidation and doesn't introduce sidewall impacts. The CNT can be adjusted in well alienated tight bundles without forming mats and clusters in case of acid oxidized SWCNTs. Air can be used for the thermal oxidation of CNTs resulting in the extraction of amorphous carbon and other carbon containing impurities. Air oxidation of carbon nanotubes is studied by varying the temperature from 480-750 degrees Celsius, and it was found that high temperature tends to open internal cavities or breaking of cylindrical walls. Carbon dioxide has also been used for removing amorphous carbon by converting it into CO₂ and subsequently to methane by hydrogen treatment. Wang and coworkers have discussed in their article the safer use of ammonia instead of hydrogen.(Y. Wang et al., 2006)

- 3. Physical Purification:** Several physical methods of purification, such as ultrasonication, filtration chromatography and surfactant solutions, are used for CNTs purification. During ultrasonication, sound energy is applied to CNTs in solvents such as dichloromethane or O-dichlorobenzene. Lu *et al* have found that bending and buckling defects are found at high concentration. Thinning of nanotubes is caused due to stripping of the external graphite layer and the structure damage would depend on the solvent.(Lu et al., 1996)The ultrasonication method is found to be effective for the functionalization of surface of multiwalled nanotubes.

Filtration by membranes of different pore diameters have been conducted by Abatamarco *et al.*(Abatamarco et al., 1999)High Performance Liquid Chromatography (HPLC) and Size Exclusion Chromatography (SEC) have also been used for the purification and disconnection of carbon nanotube bundles. It is found that CNTs have tendency to self-associate in microscale aggregates, therefore, surfactant solutions are crucial to obtain individual tubes. Sodium dodecyl sulfate (SDS) and Dodecyl-benzene sodium sulfonate (NaDDBS) are usually used to disperse CNTs' aggregates.

- 4. Characterization:** The most important techniques for the characterization of CNTs are electromagnetic spectroscopy (UV-visible, IR, photoluminescence), NMR, XRD, and light scattering techniques, namely Dynamic Light Scattering (DLS) and Raman spectroscopy. Electron microscopy techniques, Scanning Electron microscopy (SEM) and transmission electron microscope (TEM) are also applied for characterizing CNTs. SEM is used for the analysis of CNT morphology. Atomic Force Microscope (AFM) is also very useful in this regard.

CNTs possess some important traits of strength, conductivity, size and weight. It is one of the the strongest materials known due to the strong sp² bond along with seamless hexagonal network. The Young's modulus of CNT is 1 Tpa-1.8 Tpa which is responsible for many applications including probe tips of scanning microscopy. Application of CNT in aerospace as space elevator results from its mechanical properties and light weight. Electrical properties of CNTs are affected by scattering and defects in the inner wall. CNTs possess superior thermal conductivity and exhibit "ballistic conduction". Their thermal conductivity is dependent on the environment and temperature. They show superconductivity below 20 K due to strong in-plane carbon-carbon bonds. Their thermal conductivity is huge even in the case of mass examples. Optical properties of CNTs are important and related to their one-dimensional structure. Chemical response of carbon

nanotubes can be identified by the pi-orbital difference resulting from increased curvature as compared to graphene sheets. This causes difference in reactivity between the side-wall and end-cap of nanotubes; lesser the diameter more the reactivity.(Lordi & Yao, 2000)

IV. FUNCTIONALIZATION

Covalent functionalization can be carried out by introducing the functional groups on the side walls to afford amine functionalized, sulfhydryl functionalized or carboxylated carbon nanotubes. Though CNTs are potential candidates for biomedical applications, their use in vivo is restricted due to high aspect ratio and strong pi-pi interactions between the tubes. The assembling is responsible for water insolubility. Dispersibility of pristine CNTs can be enhanced by covalent functionalization of the side walls and the tips by reductive alkylation, oxidation by acids, diazonium salt addition and dipolar addition of azomethine ylides.(Zhou et al., 2019)Jain *et al* have functionalized the MWCNTs with strong mineral acids. Refluxing of pristine MWCNTs for a period of 4 hrs was found sufficient to obtain hydrophilic and biocompatible CNTs with minimum tissue accumulation and the effect of inflammation. All the experiments were conducted on mice. Pristine MWCNTs were found to impart more hepatotoxicity than the carboxylated CNTs. The toxicity of functionalized MWCNTs critically depended on the functionalization density, more the carboxyl groups lower the density. To get different degrees of functionalization, oxidation with H₂SO₄-HNO₃ (1:3) was carried out for the time period of 1-8 hrs. Mice were injected with Tc-99M-labelled carbon nanotubes through intravenous route to carry out the quantitative distribution studies. It was observed that well individualized multi walled CNTs of shorter lengths (<500 nm) and higher surface carboxyl density >3 μ mol/mg (degrees of oxidation) did not remain in the reticuloendothelial system (RES) organs and gets cleared out of the systemic circulation via renal route. CNTs with larger lengths are mainly excreted in faeces via the biliary pathway.(Jain et al., 2011)Surface carboxylation studies on MWCNT were carried out by Raymond group in 2013 and the resultant side wall functionalized CNTs were studied for bioactivity in the terms of inflammasome-activation and cell viability. Firstly, the raw multiwalled CNTs were purified by HCl to remove amorphous layer of carbon and metal impurities such as nickel because the impurities may affect the bioactivity. The purified MWCNTs were further functionalized by nitric acid. It was found that the so obtained COOH functionalized MWCNTs showed profound reduction in cytotoxicity and bioactivity. In case of raw or purified multiwalled CNTs large agglomerates are formed even after using lipid/protein dispersants and the occurrence of bioactivity is believed to be due to these agglomerated. However, as functionalized CNTs are well dispersed in water, the bioactivity is decreased. Thus, the bioactivity depends on the surface properties(Hamilton Jr et al., 2013)

Non covalent functionalization is able to preserve the intrinsic properties of carbon nanotubes while adding the new functionality. Non-covalent functionalization methods preserve conformation of the immobilized biomolecules whereas covalent functionalization's tend to affect the sp² structures of CNTs. Non-covalent functionalization can be achieved by pi-pi interactions, CH-pi interactions, electrostatic interactions between carbon nanotubes and biomolecules. SWCNTs have been non covalently functionalized with the hydrophobic moieties covalently attached to polyethyleneimines (PEIs) of different molecular weights through phospholipid moiety or directly attached hydrophobic alkyl moieties. The functionalized nanotubes possessed increased transfection efficiency than the underivatized

ones and proved to be efficient gene delivery vectors. The *in vivo* studies were carried out on mice and the largest expression was observed through polyethylene glycol linker. (Behnam et al., 2013) In the literature report by, non-covalently functionalized SWCNTs have been used in the form of DSPE-PEG-PEI/CNT(1,2-distearoyl-sn-glycero-3-phosphoethanolamine-N-[amino(polyethyleneglycol)-2000]- Polyethyleneimine /CNT for the effective delivery of small interfering RNA which is used to downregulate the gene expression. (Siu et al., 2016)

V. APPLICATIONS

The knowledge of the properties will assist to understand the wide applicability of CNTs in the fields of energy, sensing, nanomedicine and environment. CNTs can be used as fillers for different polymers to enhance the desired electrical, mechanical and thermal properties of polymers. Chemical, molecular and biological sensors composed of CNTs are of great importance and have wide scope. For capacitance-based sensors, CNTs are used as an electrode for high electric fields at the tips for the ionization of gases. CNT-based biosensors have better reproducibility and sensitivity and play significant role in cancer treatment, detection of pathogenic bacteria and as nano vehicles for drug delivery. Electrochemical biosensors can be modified with MWCNTs and gold nanoparticles (AuNPs) to show broad linear range and have low limit of detection. MWCNT based sensors have been developed to detect many analytes such as quercetin, heavy metals in vegetable samples, bilirubin in blood, nitrogenous bases, pyridoxine in pharmaceutical industries, cholesterol level, anti-cancer drug capecitabine (CPT), erlotinib HCl (ETHC), methdilazine (MDH), flufenamic acid, mefenamic acid and cetirizine (CTZ) in human urine. CNTs exhibit great antibacterial and antifungal potential. Piezoresistive sensors based on MWCNTs on different substrates such as polydimethyl siloxane (PDMS), thermoplastic urethane have been developed and they were found to show good sensitivity and remarkable stability. MWCNT based gas sensors have been developed for the detection of NO_x, methane, ammonia, Sulphur dioxide and chlorine. The role of CNT in developing high capacity-high power supercapacitor and low voltage-high temperature actuators is remarkable. For the preparation of cantilever of nanoelectromechanical systems (NEMS), CNTs are perfect to provide chemical inertness and high stiffness. Nanotube transistors and circuits with high performance can be made by the application of CNTs. SWCNTs offer promising technologies for hydrogen- storage due to their light mass. The current interest in CNT composites is growing as these are strongest materials and have superior thermal and electrical conductivities than silver and diamond.

VI. SENSORS

The scope of carbon nanotubes has been reported for use as the probe tips in applications like the atomic force microscopy. Covalently functionalized nanotubes have been applied as nanometer sized probes in the areas of biology as well as chemistry. (Wong et al., 1998) Amide-linked groups were synthesized by nanotube chemical modification involving the tip end coupling of amines and carboxyl groups. The application of the coupling reaction in the aqueous and non-aqueous chemistry has made it significant in the field of nanotube functionalization. These modified nanotubes have been used as the AFM tips to titrate acid-base and to evaluate binding forces of single protein–ligand pairs. The modified CNTs have also been used to image the patterned-samples according to the molecular interactions. Additionally, as carboxyl groups can be derivatized by a number of

well-known reactions, it is possible to prepare a range of functionalized nanotube tips to create molecular probes with varied applications.

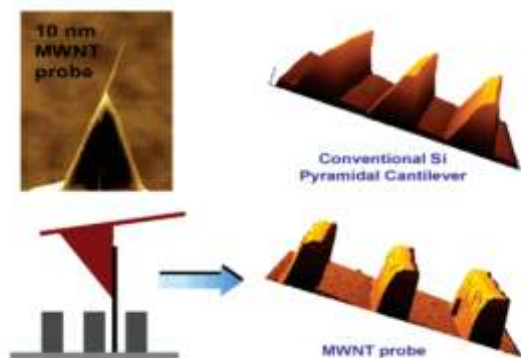

Figure 7: Comparison of the AFM depictions captured from the multiwalled CNT probe and the silicon probe. (Valcárcel et al., 2007) Reprinted with permission from Valcárcel, M., Cárdenas, S. & Simonet, B. M. Role of Carbon Nanotubes in Analytical Science. *Anal. Chem.* 79, 4788–4797 (2007). Copyright (2007) American Chemical Society.

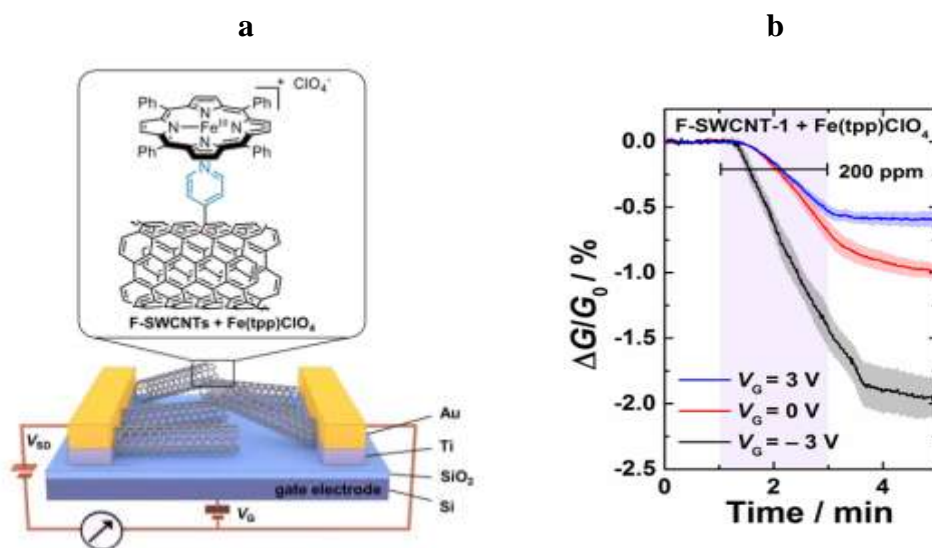

Figure 8: (a) Schematic illustration of the CO sensor encompassing iron porphyrin and SWCNTs (pyridyl-functionalized). (b) The Conductance curves of the sensor F-SWCNT-1 along with $\text{Fe}(\text{tpp})\text{ClO}_4$ towards exposure of 2 min at 200 ppm of CO at a gate voltage of +3, 0, -3 V. (Savagatrup et al., 2017) Reprinted with permission from Savagatrup, S. et al. Bio-Inspired Carbon Monoxide Sensors with Voltage-Activated Sensitivity. *Angew. Chemie* 129, 14254–14258 (2017). Copyright (2017) Wiley-VCH Verlag GmbH & Co. KGaA, Weinheim.

The miniaturized gas ionization sensors having carbon nanotubes have also been developed. Ionization microsensors with electrical breakdown of array of gases and gas mixtures at CNT tips have been developed by Modi. Due to the sharp tips of CNTs, high electric field is produced at relatively low voltages thus enabling the compact, battery

powered and the safe operation of these sensors. The sensors possess high selectivity and sensitivity and are not affected by the external changes of temperature, moisture or gas flow. These low-cost sensors can be useful for a number of applications like monitoring the environment-, gas detection for the counter-terrorism and sensing in the chemical processing plants. CNTs are also important as electrodes of capacitance-based sensors in order to generate high electric fields at their tips for the ionization of gases.(Modi et al., 2003)

Semiconducting SWCNTs coated with glucose oxidase (GOx) are used as versatile pH biosensors. For the immobilization of GOx, CVD or laser-ablated grown nanotubes are quite suitable. The controlled attachment of the redox enzyme GOx to the CNT sidewall is performed by using a linking molecule. Attachment of the enzyme to SWCNT results in the decrease in conductance which is the result of change in tube capacitance after immobilization of the enzyme. When glucose is added to the enzyme-coated-CNTs, the change in the conductance of the pH-sensor is observed indicating the capability of the sensor to measure enzymatic activity at single-nanotube level.(Besteman et al., 2003)

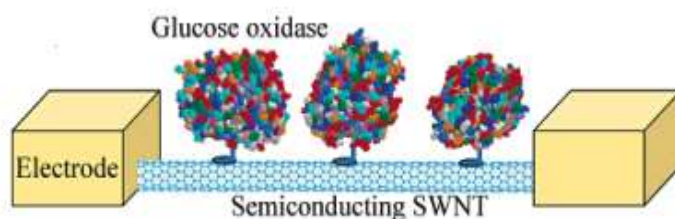

Figure 9: Electrodes connecting SWCNT with GOx. (Besteman et al., 2003) Reprinted with permission from Besteman, K., Lee, J.-O., Wiertz, F. G. M., Heering, H. A. & Dekker, C. Enzyme-coated carbon nanotubes as single-molecule biosensors. *Nano Lett.* 3, 727-730 (2003). Copyright (2003) American Chemical Society.

Applications of carbon nano tubes in cancer treatment, drug delivery system in peptide delivery, cellular uptake, nucleic acid delivery, and drug delivery have been explored. The functionalized CNT exhibit low toxicity and are not immunogenic, thus such systems hold great potential in the field of nanobiotechnology and nanomedicine. The electrochemical sensors with the CNT have been reported to exhibit the general application in the biomedical research.

The biosensors-based CNT arrays shown to be suitable for deoxyribonucleic or ribonucleic acids (DNA or RNA) analysis. Sensor nanotubes have been modified by oligonucleotides e.g. guanine for their application in biosystems.(Koehne et al., 2004) The various aspects of CNT in gas/vapor sensors for the environmental applications have been explored. Varghese *et al.* demonstrated capacitive sensing of the CO with the pristine CNTs, even though only at the concentrations of 100 per cent. Pristine CNTs are used in resonance frequency-based spotting of carbon monoxide; in these sensors, the adsorption of carbon monoxide was detected as change in resonance frequency of active layer. CNTs decorated with metal or metal oxide NPs has indicated to be most promising for the detection of H₂S as shown by DFT calculations, Zhang et al. suggested the potential of Au- and Pt decorated CNTs for sensing of both H₂S and SO₂.(Schroeder et al., 2018)

- **Aqueous Environmental Sensing:** The trace analytes spotting in liquid phase is crucial for the environmental monitoring, the water quality evaluation and detection of health problems. The wide surface area and the excellent chemical stability of the CNTs make them encouraging aqueous chemical sensors. PAA (poly-1-aminoanthracene)/SWCNT composites displayed the high electroconductivity and the thermal stability compared to other systems (PPy /SWCNT and the PANI (polyaniline)/ SWCNTs) and retained sensitivity to pH 2–12 over the 120 days.
- **CNT-Based Metal Ion Sensing:** Toxic metal ions in the water lead to environmental and health issues. Although some metals viz., iron, zinc, manganese, cobalt, and copper, are essential for normal functioning in living organisms at the low concentrations, but the concentration above certain limits is detrimental to health. For example, even minute amounts of some of the metal ions such as cadmium, lead, nickel, arsenic, chromium, cobalt and mercury are highly toxic. Due to the wide surface area, minute size, the ease of functionalization as well as excellent electrical conductivity, CNTs are employed as an electrode material in the identification of toxic metal ions. Further, CNTs are also a wonderful sorbent for various metal ions. Some of specialized reviews are also available for metal ion based sensing.
- **CNT-based sensors for food and agriculture applications:** There are a number of CNT-based sensors used in the food industry due to their low power consumption, small size, and their potential to identify complex analytes permitting the production of the economically feasible sensors that are the perfect for the tracking of product as well as management of the supply chain. CNT-based sensors incorporated into chip allowed the real-time information on state of food by smartphones or other connected devices for the use in smart packaging, food spoilage, fruit ripening, and pesticide detection.
- **Food QualityFruit Ripeness:** The presence of ethylene assessed by carbon nanotube-based sensors was demonstrated both computationally and experimentally. No sensitivity was observed by the pristine CNTs toward ethylene(C_2H_4) gas at R.T. and selector moieties are required for the activity. Leghrib et al. reported the detection of C_2H_4 at R.T. utilizing MWCNTs with SnO_2 NPs. Although the chemiresistors responded to as low as 3 ppm of ethylene, interference from NO_2 was reported. Esser et al. succeeded in developing the ethylene selective sensor by coordinating fluorinated tris(pyrazolyl)- borate copper(I) complex to the SWCNTs that was capable of forming air-stable complexes with the ethylene. The authors demonstrated sensor's selectivity and advantages by performing studies on wide variety of the fruit samples.
- **Taste and Smell:** Additionally, to scanning the fruit ripeness, CNT sensors are utilized in realizing the smell and taste of different foods. Such sensors are viz., electronic tongues and noses (e-tongues and e-noses) have been explored. There are a number of reviews available on metal oxide- and the polymer-based electronic noses, the bioelectronic noses, electronic noses for food, medical applications, and the computational analysis of electronic noses. CNT sensors are studied with olfactory receptors from humans, rodents, insects, and canines. In 2009, Park and co-workers first illustrated the usage of the human olfactory proteins for the detection of odorants.

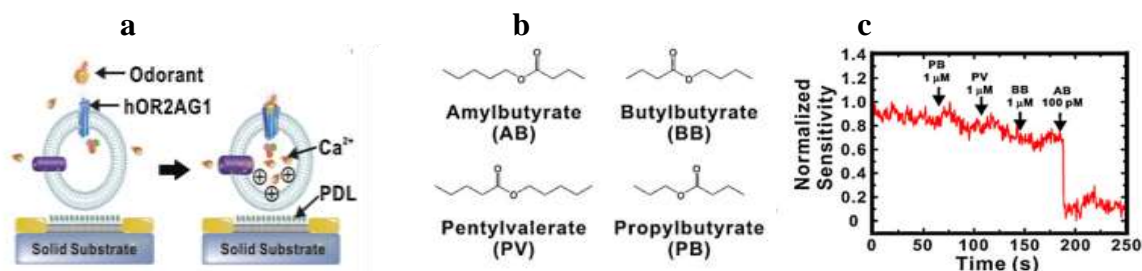

Figure- 10: (a) A probable mechanism for NBN devices response. hOR2AG1 protein trapped odorant after injecting the target odorant activated the pathways of signal in nanovesicles, and ultimately induced Ca²⁺ influx via channels of calcium ion. The enhancement of positive charges in nanovesicles provided a field effect on single-walled CNT-FETs and decreased their conductance. (b) The Chemical structures of distinct molecules of odorant that could be distinguished using hOR2AG1. (c) Graph illustrating the changes in conductance in the real-time after insertion of distinct odorant molecules. (Jin et al., 2012) Reprinted with permission from Jin, H. J. *et al.* Nanovesicle-based bioelectronic nose platform mimicking human olfactory signal transduction. *Biosens. Bioelectron.* 35, 335–341 (2012). Copyright (2012) Elsevier B.V.

- 1. Food Spoilage:** CNT-based Sensors have been reported to be incorporated inside of packaging to detect food spoilage. These sensors detect the volatile biomarkers indicative of the spoilage of food. The biomarkers comprise the ammonia and biogenic amines for the spoilage in fish and meat fish products, 1-octen-3-ol for grain fungal infections, and the hexanal for the spoilage in milk. Work on a considerable number of sensors for ammonia has also been established. (Schroeder et al., 2018)
- 2. Hydrogen Storage:** Hydrogen being plentiful element on the earth is present less than 1 per cent is present as H₂(g). It is present as hydrogen in water as well as bound to liquid or gaseous hydrocarbons. Grätzel reviewed use of sunlight for hydrogen production from water using photovoltaic cells and water electrolysis. (Grätzel, 2001) Hydrogen being lightweight, ample and its oxidation product (water) is ecofriendly, could serve as good synthetic fuel although there are safety issues in storing hydrogen. The search for innovative materials with high hydrogen storage capacity have been developed. The hydrogen gas is condensed to high density inside SWCNTs without adsorption within a standard mesoporous activated carbon as shown by temperature-programmed desorption spectroscopy. These can be used as storage material for fuel-cell electric vehicles. (Dillon et al., 1997) Formation of nanocomposites by copper oxide (II) CuO nanoplates with the support of titanium dioxide (TiO₂) nanosheets utilized for the applications in water-splitting in which CuO nanoplates form the 3D conductive structures by bisecting each other, and TiO₂ sheets positioned on CuO nanosheets without any aggregation. These types of composites have applications as the anode in Li-ion batteries (LiBs). (L. Wang et al., 2016)
- 3. Supercapacitors:** Electrochemical capacitors (supercapacitors) and ultracapacitors have gained the attention because of their longer life cycle, high capacity and potentially high power. Niu et al 1997 demonstrated the synthesis of a carbon nanotube electrode from catalytically grown carbon nanotubes with high surface area, lower resistivity and the

high stability which otherwise cannot be realized with activated carbon or carbon fiber. The individual cells in devices containing 38 wt% of H_2SO_4 as the electrolyte are shown to have very high specific capacitances viz., 102 and 49 F/g measured at 1 and 100 Hz, respectively. Each cell could reach 8000 W/Kg power densities. In CNTs, power density upto 20 KW/Kg with energy density is 7 Wh/Kg may be obtained.(Niu et al., 1997) The structure of nanotubes is very important for their utility in electrochemical storage devices. In most batteries, the graphitic carbon anodes are preferred over metallic Li electrodes in terms of safety and the cycle efficiency although use of the graphite leads to considerable reduction of energy density than metallic Li. In principle, the performance of these Li-nanotube systems can considerably improve the capacity of the Li-ion batteries by utilizing both the nanotube exteriors and the interiors. Li ions can enter the tubes through the topological defects with minimum nine-sided rings, or via the ends of open-ended nanotubes but is not allowed through sidewalls. Their motion is not the diffusion limited inside, provided the tubes are relatively short. The materials with better properties can be obtained for electrochemical storage using “damaging” nanotube ropes by either thermochemical or the mechanical methods.⁵¹(Meunier et al., 2002)

The Supercapacitors fill the gap of the conventional capacitors and batteries, in terms of the energy and power densities. They are an attractive choice for their portable energy storage application which makes them beneficial when the conventional capacitors and batteries are to be over-dimensioned due to the unfavorable power-to-energy ratio. The SWCNTs and MWCNTs are important due to their properties regarding electrochemical supercapacitor electrodes. Pan et al. reviewed the carbon nano tubes as supercapacitors.(Pan et al., 2010) The flexible symmetric paper supercapacitor based on $BaTiO_3$ /PVA/CNTs structure was proposed by Aval et al., 2018 revealing another type of flexible supercapacitor that can be applied to the soft electronic.(Aval et al., 2018)

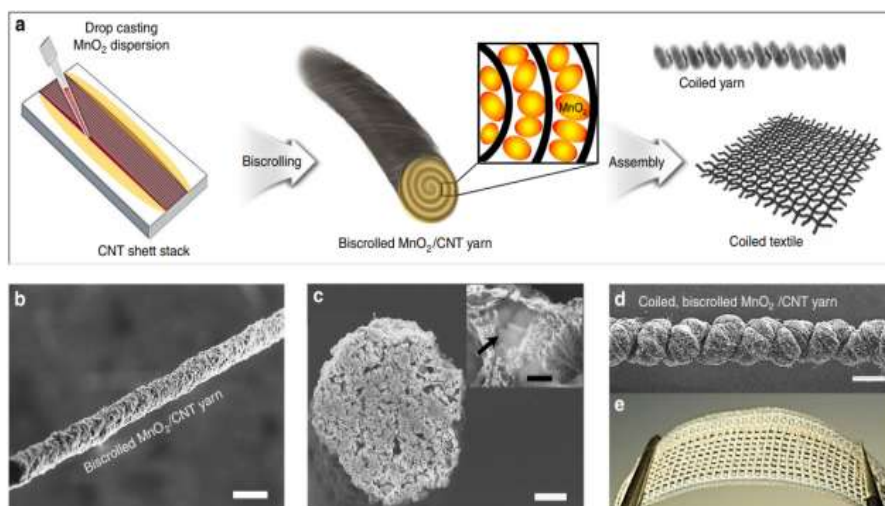

Figure 11: Schematic illustration of (a) Schematic description of MnO_2 -loaded bisrolled yarn electrode and bisrolled yarn-based coiled supercapacitor fabrication. (b,c) SEM morphology of bisrolled MnO_2 /CNT yarn electrode and its cross-section (d) SEM image of the 5-ply, bisrolled MnO_2 /CNT yarn coiled via twist insertion (e) Photograph of non-coiled bisrolled yarn electrodes knitted into a fabric.(Choi et al., 2016) (a) Reprinted with permission from Choi, C. *et al.* Improvement of system capacitance via weavable superelastic bisrolled yarn supercapacitors. *Nat. Commun.* 7, 13811 (2016). Copyright (2016) Springer Nature.

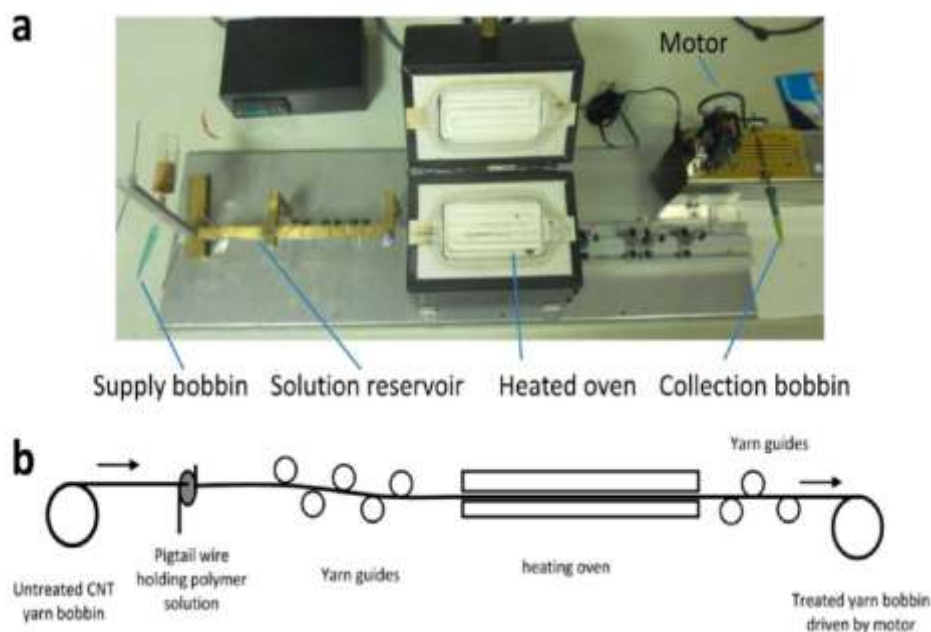

Figure 12: (a) Image, and (b) graphic of the continual dip-coating line utilized for the solution polyaniline nanowire and the gel PVA-H₃PO₄. (Su et al., 2014) Reprinted with permission from Su, F., Miao, M., Niu, H. & Wei, Z. Gamma-Irradiated Carbon Nanotube Yarn As Substrate for High-Performance Fiber Supercapacitors. *ACS Appl. Mater. Interfaces* 6, 2553–2560 (2014). Copyright (2014) American Chemical Society.

Supercapacitors (SCs) having high capacitance, long-term durability, and a high rate of charge-discharge is today's demand owing to the development of wearable devices. Especially, durable and flexible SCs are needed for utilization in wearable devices. The SCs offered high durability with greater than 99.9% capacitance retention after 50 000 bending cycles. It was also observed that the orientation angle of the CNT sheets w.r.t the current flow direction (θ) was critical for determining SCs performance. The SCs with CNT sheets oriented in the current flow direction ($\theta = 0^\circ$) revealed a higher scan rate and robustness in comparison with other CNT sheet orientations ($\theta = 45$ or 90°) due to the ease of access of charge carriers to electrodes of the entire CNT sheet. Well-designed durable and flexible CNT-SCs may drastically enhance the performance of forthcoming flexible devices. (Komatsubara et al., 2022) The fabrication of the high-performance, self-standing composite sp^2 -carbon supercapacitor electrodes using the single-walled carbon nanotubes (CNTs) as conductive binder was explored and it was observed that there was a reduction of series resistance in the film through the CNT conductive network and especially to the surface treatment of the stainless-steel current collector. (Rangom et al., 2015)

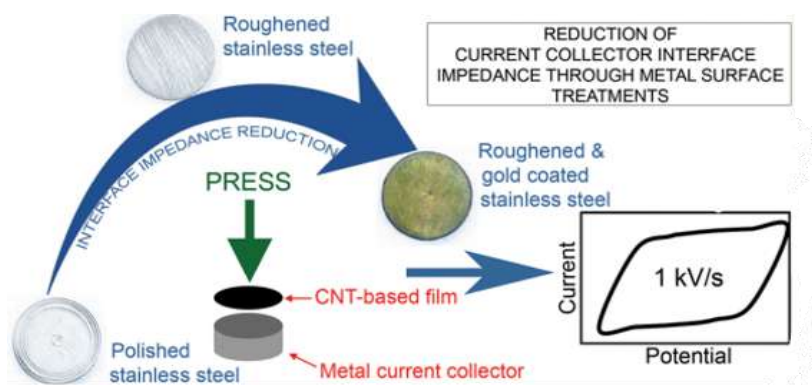

Figure- 13 : Metal surface treatment for interface impedance reduction.(Rangom et al., 2015)Reprinted with permission from Rangom, Y., Tang, X. (Shirley) & Nazar, L. F. Carbon Nanotube-Based Supercapacitors with Excellent ac Line Filtering and Rate Capability via Improved Interfacial Impedance. *ACS Nano* 9, 7248–7255 (2015) Copyright (2015) American Chemical Society.

- 4. Composites:** Due to the unique mechanical, thermal and electrical properties of CNTs including those of various types of CNT composites have been successfully fabricated. CNTs are very effective as conductive fillers for polymers. They are used for thermal management in composites due to their high thermal conductivity values. They are used as reinforcing phase in case of polymer matrices because of their high tensile strength (200 GPa), aspect ratios $\approx 10^3$ and ≈ 500 times more surface area/gram than typical C-fiber. They have been used as reinforcement for polymers.(Andrews & Weisenberger, 2004)

Gojny *et al* have studied the effect of different types of CNTs on mechanical properties of epoxy-based composites. The epoxy matrix system used for the study consists of modified DGEBA-based epoxy resin (L135i) containing amine hardner (H137i). Different CNTs, SWCNTs, DWCNs (purified and amino functionalized) and MWCNTs (purified and amino functionalized) were produced using the CVD method. The data was discussed as specific surface area (SSA), particle shape and chemical functionalization of surface. With large SSA of CNTs, dispersibility is found to be difficult. With amino groups, dispersibility is improved and CNT- suspension was stabilized. Fracture toughness is found to be increased due to the nanomechanical mechanisms in context to fibre-shape of carbon nanotubes particularly with amino-DWCNTs. Chemical functionalization of the surface of CNTs is an important factor for improving dispersibility and interfacial bonding. In case of amino-DWCNTs, the strength (+10%), stiffness (+15%) and fracture toughness (+43%) significantly improved.(Gojny et al., 2005) CNTs have been incorporated into various conjugated polymer matrix (PANI, PPY) for their applicability as supercapacitor electrodes. Sulfonated MWCNT-PANI composites were synthesized by oxidative polymerization in HClO_4 solution, water-soluble MWCNTs, in turn, were prepared by diazotization. The composites possessed improved electrochemical properties (max. 515 Fg^{-1} at 76.4wt% PANI) and high cycling stability (<10% capacity loss in 1000 cycles).(Zhu et al., 2011)Shawky *et al.* demonstrated the synthesis and characterization of a carbon nanotube/polymer nanocomposite membrane for water treatment. A polymer grafting process was used to prepare multi-walled carbon nanotube (MWCNT)/aromatic polyamide (PA)

nanocomposite membranes. The dispersion of MWCNTs in PA matrix was confirmed by SEM and AFM studies. In addition to the normal removal of sodium chloride by all the membranes tested, the high molecular weight humic acid was also removed by these membranes. The increase of elimination from 54 to 90% of humic acid using MWCNT composite membranes was observed when MWCNT loading increased from 0 to 10 mg/g.(Shawky et al., 2011)

Liu *et al* have synthesized low-protein adsorption surfaces and ultrafiltration antifouling membranes for protein separation. The amphiphilic and protein-resistant properties were inserted by the polymerization viz., sequential atom transfer radical polymerization in the synthesis of multiwalled carbon nanotubes functionalized with the poly(sulfone) (PSF) and the poly (sulfobetaine methacrylate) (PSBMA) (MWCNT-PSF/PSBMA). It was reported that 1 wt % MWCNT PSF/PSBMA addition to PSF films remarkably enhanced their protein-resistant properties, as the composite film reveals a 4.4 percent protein adsorption than poly(styrene) Petri dishes. The PSF/MWCNT-PSF/PSBMA composite has been applied to prepare antifouling ultrafiltration membranes for protein separation.(Liu et al., 2010) Later, in 2011, another phase inversion method was applied to synthesize multi-walled carbon nanotube/polyethersulfone (C/P) blend membranes in the treatment of fouling control water treatment by Celik *et al*. The results demonstrated that the foulant on bare PES membranes was 63 percent more than the C/P blended membrane for 2% MWCNTs contents.(Celik et al., 2011)

Studies conducted on membrane fouling resulting from protein adsorption showed that it could be minimized by importing the MWCNTs to blend membrane. The ultrafiltration membrane of varying compositions were synthesized using classical phase-inversion method with the blends of polysulfone (PSF) and the functionalized MWCNTs in DMF. The pure water flux of the blend membranes increased with the content of functionalized MWCNTs. There was an increment up to 0.19% in the pure water flux of the blend and then gradually decreased, surface hydrophilicity also increased along with the contents of functionalized MWCNTs., the average pore size and pore structure changed with content of functionalized MWCNTs up to 0.19%, and thereafter there is decrease of the average pore size.(Qiu et al., 2009)

VII. FUTURE PERSPECTIVES

CNT based research has tremendous potential and efforts are needed to make purified carbon nanotubes with less defects in cost-effective manner. The price of CNTs is a reflection of the prize of the carbon source. Therefore, finding new economical sources is of utmost need towards revolutionizing the advancements in this particular field. Search for economical and sustainable novel carbon sources, development of new techniques for synthesizing carbon nanotubes with advanced features will boost its application in the areas of therapy including gene therapy, drug delivery and also to innovate new devices.

REFERENCES

- [1] Abatemarco, T., Stickel, J., Belfort, J., Frank, B. P., Ajayan, P. M., & Belfort, G. (1999). Fractionation of multiwalled carbon nanotubes by cascade membrane microfiltration. *The Journal of Physical Chemistry B*, 103(18), 3534–3538.

- [2] Ando, Y., & Zhao, X. (2006). Synthesis of carbon nanotubes by arc-discharge method. *New Diamond and Frontier Carbon Technology*, 16(3), 123–138.
- [3] Andrews, R., & Weisenberger, M. C. (2004). Carbon nanotube polymer composites. *Current Opinion in Solid State and Materials Science*, 8(1), 31–37.
- [4] Anzar, N., Hasan, R., Tyagi, M., Yadav, N., & Narang, J. (2020). Carbon nanotube-A review on Synthesis, Properties and plethora of applications in the field of biomedical science. *Sensors International*, 1, 100003.
- [5] Aval, L. F., Ghoranneviss, M., & Pour, G. B. (2018). High-performance supercapacitors based on the carbon nanotubes, graphene and graphite nanoparticles electrodes. *Heliyon*, 4(11).
- [6] Awasthi, K., Srivastava, A., & Srivastava, O. N. (2005). Synthesis of carbon nanotubes. *Journal of Nanoscience and Nanotechnology*, 5(10), 1616–1636.
- [7] Baghel, P., & Kaushal, P. (2022). Rapid synthesis of carbon nanotubes from *Prosopis Juliflora* biochar using microwave irradiation. *Materials Science and Engineering: B*, 286, 115987.
- [8] Baghel, P., Sakhiya, A. K., & Kaushal, P. (2022). Ultrafast growth of carbon nanotubes using microwave irradiation: characterization and its potential applications. *Heliyon*.
- [9] Behnam, B., Shier, W. T., Nia, A. H., Abnous, K., & Ramezani, M. (2013). Non-covalent functionalization of single-walled carbon nanotubes with modified polyethyleneimines for efficient gene delivery. *International Journal of Pharmaceutics*, 454(1), 204–215.
- [10] Besteman, K., Lee, J.-O., Wiertz, F. G. M., Heering, H. A., & Dekker, C. (2003). Enzyme-coated carbon nanotubes as single-molecule biosensors. *Nano Letters*, 3(6), 727–730.
- [11] Bogdanova, A. R., Krasnikov, D. V., & Nasibulin, A. G. (2023). The role of sulfur in the CVD carbon nanotube synthesis. *Carbon*, 118051.
- [12] Celik, E., Park, H., Choi, H., & Choi, H. (2011). Carbon nanotube blended polyethersulfone membranes for fouling control in water treatment. *Water Research*, 45(1), 274–282.
- [13] Chen, C.-M., Chen, M., Peng, Y.-W., Lin, C.-H., Chang, L.-W., & Chen, C.-F. (2005). Microwave digestion and acidic treatment procedures for the purification of multi-walled carbon nanotubes. *Diamond and Related Materials*, 14(3–7), 798–803.
- [14] Choi, C., Kim, K. M., Kim, K. J., Lepró, X., Spinks, G. M., Baughman, R. H., & Kim, S. J. (2016). Improvement of system capacitance via weavable superelastic bistructured yarn supercapacitors. *Nature Communications*, 7(1), 13811.
- [15] Choudhary, N., Hwang, S., & Choi, W. (2014). Carbon nanomaterials: a review. *Handbook of Nanomaterials Properties*, 709–769.
- [16] Dai, H., Rinzler, A. G., Nikolaev, P., Thess, A., Colbert, D. T., & Smalley, R. E. (1996). Single-wall nanotubes produced by metal-catalyzed disproportionation of carbon monoxide. *Chemical Physics Letters*, 260(3–4), 471–475.
- [17] Delpeux, S., Szostak, K., Frackowiak, E., & Béguin, F. (2005). An efficient two-step process for producing opened multi-walled carbon nanotubes of high purity. *Chemical Physics Letters*, 404(4–6), 374–378.
- [18] Dillon, A., Jones, K. M., Bekkedahl, T. A., Kiang, C. H., Bethune, D. S., & Heben, M. J. (1997). Storage of hydrogen in single-walled carbon nanotubes. *Nature*, 386(6623), 377–379.
- [19] Gojny, F. H., Wichmann, M. H. G., Fiedler, B., & Schulte, K. (2005). Influence of different carbon nanotubes on the mechanical properties of epoxy matrix composites—a comparative study. *Composites Science and Technology*, 65(15–16), 2300–2313.
- [20] Gopinath, P., & Gore, J. (2007). Chemical kinetic considerations for postflame synthesis of carbon nanotubes in premixed flames using a support catalyst. *Combustion and Flame*, 151(3), 542–550.
- [21] Gore, J. P., & Sane, A. (2011). Flame synthesis of carbon nanotubes. *Carbon Nanotubes-Synthesis, Characterization, Applications*, 1, 16801.
- [22] Grätzel, M. (2001). Photoelectrochemical cells. *Nature*, 414(6861), 338–344.
- [23] Hamilton Jr, R. F., Xiang, C., Li, M., Ka, I., Yang, F., Ma, D., Porter, D. W., Wu, N., & Holian, A. (2013). Purification and sidewall functionalization of multiwalled carbon nanotubes and resulting bioactivity in two macrophage models. *Inhalation Toxicology*, 25(4), 199–210.
- [24] Hata, K., Futaba, D. N., Mizuno, K., Namai, T., Yumura, M., & Iijima, S. (2004). Water-assisted highly efficient synthesis of impurity-free single-walled carbon nanotubes. *Science*, 306(5700), 1362–1364.
- [25] Height, M. J., Howard, J. B., Tester, J. W., & Vander Sande, J. B. (2004). Flame synthesis of single-walled carbon nanotubes. *Carbon*, 42(11), 2295–2307.
- [26] Iijima, S. (1991). Helical microtubules of graphitic carbon. *Nature*, 354(6348), 56–58.

- [27] Jain, S., Thakare, V. S., Das, M., Godugu, C., Jain, A. K., Mathur, R., Chuttani, K., & Mishra, A. K. (2011). Toxicity of multiwalled carbon nanotubes with end defects critically depends on their functionalization density. *Chemical Research in Toxicology*, 24(11), 2028–2039.
- [28] Jin, H. J., Lee, S. H., Kim, T. H., Park, J., Song, H. S., Park, T. H., & Hong, S. (2012). Nanovesicle-based bioelectronic nose platform mimicking human olfactory signal transduction. *Biosensors and Bioelectronics*, 35(1), 335–341.
- [29] José- Yacamán, M., Miki- Yoshida, M., Rendon, L., & Santiesteban, J. G. (1993). Catalytic growth of carbon microtubules with fullerene structure. *Applied Physics Letters*, 62(2), 202–204.
- [30] Kato, T., Jeong, G.-H., Hirata, T., Hatakeyama, R., & Tohji, K. (2004). Freestanding individual single-walled carbon nanotube synthesis based on plasma sheath effects. *Japanese Journal of Applied Physics*, 43(10A), L1278.
- [31] Kelsall, R. W., Hamley, I. W., & Geoghegan, M. (2005). Effects of the nanometer length scale. *Nanoscale Science and Technology*. John Wiley & Sons, 19–32.
- [32] Koehne, J. E., Chen, H., Cassell, A. M., Ye, Q., Han, J., Meyyappan, M., & Li, J. (2004). Miniaturized multiplex label-free electronic chip for rapid nucleic acid analysis based on carbon nanotube nanoelectrode arrays. *Clinical Chemistry*, 50(10), 1886–1893.
- [33] Komatsubara, K., Suzuki, H., Inoue, H., Kishibuchi, M., Takahashi, S., Marui, T., Umezawa, S., Nakagawa, T., Nasu, K., & Maetani, M. (2022). Highly oriented carbon nanotube supercapacitors. *ACS Applied Nano Materials*, 5(1), 1521–1532.
- [34] Kumar, M., & Ando, Y. (2010). Chemical vapor deposition of carbon nanotubes: a review on growth mechanism and mass production. *Journal of Nanoscience and Nanotechnology*, 10(6), 3739–3758.
- [35] Lee, C. J., Lyu, S. C., Kim, H.-W., Park, C.-Y., & Yang, C.-W. (2002). Large-scale production of aligned carbon nanotubes by the vapor phase growth method. *Chemical Physics Letters*, 359(1–2), 109–114.
- [36] Lin, B., Chen, X., Chen, J., Chen, S., Lu, R., Liang, S., Cui, X., Chi, H., & Zou, L. (2023). Facile synthesis of homogeneously dispersed carbon nanotubes on TC4 alloy powder by in-situ CVD and its growth behavior. *Journal of Materials Research and Technology*, 24, 9928–9938.
- [37] Liu, Y.-L., Chang, Y., Chang, Y.-H., & Shih, Y.-J. (2010). Preparation of amphiphilic polymer-functionalized carbon nanotubes for low-protein-adsorption surfaces and protein-resistant membranes. *ACS Applied Materials & Interfaces*, 2(12), 3642–3647.
- [38] Lordi, V., & Yao, N. (2000). Molecular mechanics of binding in carbon-nanotube–polymer composites. *Journal of Materials Research*, 15(12), 2770–2779.
- [39] Lu, K., Lago, R., Chen, Y., Green, M., Harris, P., & Tsang, S. (1996). Mechanical damage of carbon nanotubes by ultrasound. *Carbon*, 34(6).
- [40] Martínez-Iniesta, A. D., Muñoz-Sandoval, E., Morán-Lázaro, J. P., Hayashi, T., Endo, M., Morelos-Gómez, A., & López-Urías, F. (2022). Phosphorus and nitrogen codoped entangled carbon nanotubes forming spongy materials: Synthesis and characterization. *Diamond and Related Materials*, 129, 109317.
- [41] Maruyama, S., Kojima, R., Miyauchi, Y., Chiashi, S., & Kohno, M. (2002). Low-temperature synthesis of high-purity single-walled carbon nanotubes from alcohol. *Chemical Physics Letters*, 360(3–4), 229–234.
- [42] Meunier, V., Kephart, J., Roland, C., & Bernholc, J. (2002). Ab initio investigations of lithium diffusion in carbon nanotube systems. *Physical Review Letters*, 88(7), 075506.
- [43] Modi, A., Koratkar, N., Lass, E., Wei, B., & Ajayan, P. M. (2003). Miniaturized gas ionization sensors using carbon nanotubes. *Nature*, 424(6945), 171–174.
- [44] Mohanapriya, S., & Lakshminarayanan, V. (2007). Simultaneous purification and spectrophotometric determination of nickel present in as-prepared single-walled carbon nanotubes (SWCNT). *Talanta*, 71(1), 493–497.
- [45] Niu, C., Sichel, E. K., Hoch, R., Moy, D., & Tennent, H. (1997). High power electrochemical capacitors based on carbon nanotube electrodes. *Applied Physics Letters*, 70(11), 1480–1482.
- [46] Nozaki, T., Ohnishi, K., Okazaki, K., & Kortshagen, U. (2007). Fabrication of vertically aligned single-walled carbon nanotubes in atmospheric pressure non-thermal plasma CVD. *Carbon*, 45(2), 364–374.
- [47] Pan, H., Li, J., & Feng, Y. (2010). Carbon nanotubes for supercapacitor. *Nanoscale Research Letters*, 5, 654–668.
- [48] Qiu, S., Wu, L., Pan, X., Zhang, L., Chen, H., & Gao, C. (2009). Preparation and properties of functionalized carbon nanotube/PSF blend ultrafiltration membranes. *Journal of Membrane Science*, 342(1–2), 165–172.
- [49] Rangom, Y., Tang, X., & Nazar, L. F. (2015). Carbon nanotube-based supercapacitors with excellent ac line filtering and rate capability via improved interfacial impedance. *ACS Nano*, 9(7), 7248–7255.

- [50] Rasheed, A., Howe, J. Y., Dadmun, M. D., & Britt, P. F. (2007). The efficiency of the oxidation of carbon nanofibers with various oxidizing agents. *Carbon*, 45(5), 1072–1080.
- [51] Rathinavel, S., Priyadharshini, K., & Panda, D. (2021a). A review on carbon nanotube: An overview of synthesis, properties, functionalization, characterization, and the application. *Materials Science and Engineering: B*, 268, 115095.
- [52] Rathinavel, S., Priyadharshini, K., & Panda, D. (2021b). A review on carbon nanotube: An overview of synthesis, properties, functionalization, characterization, and the application. *Materials Science and Engineering: B*, 268, 115095.
- [53] Raymundo-Pinero, E., Cacciaguerra, T., Simon, P., & Beguin, F. (2005). A single step process for the simultaneous purification and opening of multiwalled carbon nanotubes. *Chemical Physics Letters*, 412(1–3), 184–189.
- [54] Saifuddin, N., Raziah, A. Z., & Junizah, A. R. (2013). Carbon nanotubes: a review on structure and their interaction with proteins. *Journal of Chemistry*, 2013.
- [55] Salernitano, E., Giorgi, L., Makris, T. D., Giorgi, R., Lisi, N., Contini, V., & Falconieri, M. (2007). Purification of MWCNTs grown on a nanosized unsupported Fe-based powder catalyst. *Diamond and Related Materials*, 16(8), 1565–1570.
- [56] Savagatrup, S., Schroeder, V., He, X., Lin, S., He, M., Yassine, O., Salama, K. N., Zhang, X., & Swager, T. M. (2017). Bio- Inspired Carbon Monoxide Sensors with Voltage- Activated Sensitivity. *Angewandte Chemie*, 129(45), 14254–14258.
- [57] Schroeder, V., Savagatrup, S., He, M., Lin, S., & Swager, T. M. (2018). Carbon nanotube chemical sensors. *Chemical Reviews*, 119(1), 599–663.
- [58] Shawky, H. A., Chae, S.-R., Lin, S., & Wiesner, M. R. (2011). Synthesis and characterization of a carbon nanotube/polymer nanocomposite membrane for water treatment. *Desalination*, 272(1–3), 46–50.
- [59] Siu, K. S., Zhang, Y., Zheng, X., Koropatnick, J., & Min, W.-P. (2016). Non-covalently functionalized of single-walled carbon nanotubes by DSPE-PEG-PEI for SiRNA delivery. *SiRNA Delivery Methods: Methods and Protocols*, 151–163.
- [60] Su, F., Miao, M., Niu, H., & Wei, Z. (2014). Gamma-irradiated carbon nanotube yarn as substrate for high-performance fiber supercapacitors. *ACS Applied Materials & Interfaces*, 6(4), 2553–2560.
- [61] Thess, A., Lee, R., Nikolaev, P., Dai, H., Petit, P., Robert, J., Xu, C., Lee, Y. H., Kim, S. G., & Rinzler, A. G. (1996). Crystalline ropes of metallic carbon nanotubes. *Science*, 273(5274), 483–487.
- [62] Titirici, M.-M., White, R. J., Brun, N., Budarin, V. L., Su, D. S., del Monte, F., Clark, J. H., & MacLachlan, M. J. (2015). Sustainable carbon materials. *Chemical Society Reviews*, 44(1), 250–290.
- [63] Valcárcel, M., Cárdenas, S., & Simonet, B. M. (2007). Role of carbon nanotubes in analytical science. *Analytical Chemistry*, 79(13), 4788–4797.
- [64] Vincent, P., Panciera, F., Florea, I., Blanchard, N., Cojocar, C. S., Ezzedine, M., Taoum, H., Perisanu, S., De Laharpe, P., & Ayari, A. (2023). Observations of the synthesis of straight single wall carbon nanotubes directed by electric fields in an Environmental Transmission Electron Microscope. *Carbon*, 118272.
- [65] Wang, L., Zhang, X., Gao, H., Hu, J., Mao, J., Liang, C., Zhang, P., & Shao, G. (2016). 3D CuO network supported TiO₂ nanosheets with applications for energy storage and water splitting. *Science of Advanced Materials*, 8(6), 1256–1262.
- [66] Wang, Y., Gao, L., Sun, J., Liu, Y., Zheng, S., Kajiura, H., Li, Y., & Noda, K. (2006). An integrated route for purification, cutting and dispersion of single-walled carbon nanotubes. *Chemical Physics Letters*, 432(1–3), 205–208.
- [67] Wong, S. S., Joselevich, E., Woolley, A. T., Cheung, C. L., & Lieber, C. M. (1998). Covalently functionalized nanotubes as nanometre-sized probes in chemistry and biology. *Nature*, 394(6688), 52–55.
- [68] Zhang, Y., Shi, Z., Gu, Z., & Iijima, S. (2000). Structure modification of single-wall carbon nanotubes. *Carbon*, 38(15), 2055–2059.
- [69] Zheng, R., Li, S., Zhang, L., & Yang, Y. (n.d.). In-Situ Synthesis of High-Quality Carbon Nanotubes on Cu Powder by Constructing an Al₂O₃ Barrier Layer. Available at SSRN 4478330.
- [70] Zhou, Y., Fang, Y., & Ramasamy, R. P. (2019). Non-covalent functionalization of carbon nanotubes for electrochemical biosensor development. *Sensors*, 19(2), 392.
- [71] Zhu, Z., Wang, G., Sun, M., Li, X., & Li, C. (2011). Fabrication and electrochemical characterization of polyaniline nanorods modified with sulfonated carbon nanotubes for supercapacitor applications. *Electrochimica Acta*, 56(3), 1366–1372.
- [72] Ziegler, K. J., Gu, Z., Peng, H., Flor, E. L., Hauge, R. H., & Smalley, R. E. (2005). Controlled oxidative cutting of single-walled carbon nanotubes. *Journal of the American Chemical Society*, 127(5), 1541–1547.