

IDENTIFICATION OF DRUGS IN DIFFERENT PHARMACEUTICAL PREPARATIONS USING CHROMATOGRAPHIC TECHNIQUES

Abstract

Medicine advancement has resulted in a health-care revolution. These medications only work as intended if they are injected correctly and without foreign substances. To ensure that medicines work as intended, numerous chemical and instrumental procedures have been developed over time and are utilized in drug assessment. Since contaminants can occur in these drugs at various points during production, transit, and storage, administration of these drugs can be harmful, they must be identified and quantitated. In this context, analytical methods and tools are vital. This study underlines the value of analytical techniques and tools in establishing the qualities of the drugs. The study highlights various analytical methods that have been used in the analysis of pharmaceuticals, including Thin Layer Chromatography, High Performance Thin Layer Chromatography, High Performance Liquid Chromatography, Column Chromatography, Paper Chromatography, Gas Chromatography, and Ion-Exchange Chromatography.

Keywords: High Performance Thin Layer Chromatography (HPTLC), chromatographic separation technique; thin layer chromatography, High performance liquid chromatography, Paper chromatography, Column chromatography, Gas chromatography, Ion-exchange chromatography.

Authors

Juhi H. Rinke

Adv. V. R. Manohar Institute
Diploma in Pharmacy (Government Aided)
Wanadongri, Hingna M.S.

Swapnja B. Gunjarkar

Adv. V. R. Manohar Institute
Diploma in Pharmacy (Government Aided)
Wanadongri, Hingna M.S.

Shubham P. Bhute

Adv. V. R. Manohar Institute
Diploma in Pharmacy (Government Aided)
Wanadongri, Hingna M.S.

Chetana M. Waghale

Adv. V. R. Manohar Institute
Diploma in Pharmacy (Government Aided)
Wanadongri, Hingna M.S.

Ankit Kaikade

Adv. V. R. Manohar Institute
Diploma in Pharmacy (Government Aided)
Wanadongri, Hingna M.S.

Nikhil D. Amnerkar

Adv. V. R. Manohar Institute
Diploma in Pharmacy (Government Aided)
Wanadongri, Hingna M.S.

I. INTRODUCTION

Chromatography, also known as color writing, is a physical separation process that separates and clears compounds into distinct molecules whose distribution varies according to a variety of factors, including:

1. Solubility
2. Affinity (between polar molecules or non-polar molecules)
3. The mixed product is divided into two phases (stationary phase and mobile phase) that move at different speeds in the former directions. We will define the stationary phase (A. Wilkinson, 1997). As we all know, Russian botanist Michael Tswett found in 1901 that the chlorophyll pigment separates into various colors as it moves through the CaCO₃ column. As a result, he is regarded as the originator and father of chromatography. Archer John Porter Martin and Richard Laurence Millington were awarded the Nobel Prize in Chemistry in 1952 for their contributions to the development of different separation technologies such as separation (liquid-liquid chromatography) (S.S. Nielsen, 2010).

In a chromatographic separation the following three elements must be present: Phase:

- Sample
- Mobile
- Stationary phase (S. Aryal, 2021).

There are two different separation methods in chromatography. The first is polar stationary phase normal liquid chromatography (NPLC). The next method is reversed-phase liquid chromatography (RPLC), in which the stationary phase is non-polar and the mobile phase is polar. In contrast, the mobile phase is nonpolar. To get a proper chromatographic separation, we must select the proper stationary phase and mobile phase. The main purpose of chromatography is to distinguish between analytical methods that control the chemical composition and concentration of the sample and the original method that only separates the sample mixture without determining their concentration (K. Hostettmann, 2011).

II. CLASSIFICATION

Here are three ways we can classify and write the chromatographic process:

1. Based on the shape of the stationary phase. For example, column chromatography and planar chromatography.
2. Depending on the physical state of the stationary phase and mobile phase. For example, liquid chromatography and gas chromatography.
3. It depends on the interaction between the stationary phase and the mobile phase. Consider affinity chromatography, ion exchange chromatography, partition chromatography, adsorption chromatography, and mass separation chromatography as examples.

III. HIGH PERFORMANCE THIN LAYER CHROMATOGRAPHY (HPTLC)

1. **Introduction:** Thin-layer chromatography (TLC), with increasingly effective separation and detection limits, is called high-performance thin-layer chromatography (HPTLC), an

advanced and automated version of TLC. Other names are plate chromatography and high pressure thin layer chromatography/planar chromatography. The well-known and flexible HPTLC separation process has many advantages over other separation methods. The pore size and particle size of the adsorbent are the only differences between conventional TLC and HPTLC. This is a great analytical technique that equates to a lot of work. Depending on the type of adsorbent and solvent used on the plate, separation may occur due to adsorption, dispersion, or both. Coverage of all aspects of HPTLC fundamentals, including principles, concepts, and understanding; measurement, including implementation, optimization, usability, automation, and quality and quantity analysis; and applications including phytochemical analysis, biomedical analysis, phytoquantification, drug analysis, fingerprinting. analysis and hyphenated capabilities (HPTLC-MS, HPTLCFTIR and HPTLC scanning diode laser).

- 2. Principle:** Adsorption HPTLC is the separation principle of HPTLC, using similar technology and the same principle of TLC (adsorption chromatography). Capillary action causes penetration of heavy mobile phases. These particles move when they tend to interact with the adsorbent. Parts with a strong affinity for the stationary phase move slower. Elements that are less attracted to the stationary phase move faster. The product is separated in this way on the chromatography plate.

3. Steps involving in HPTLC



Figure 1: Instrument of High-Performance Thin Layer Chromatography

Selection of stationary phase: The type of mixture should be taken into account when selecting the stationary phase during mechanical design (K. Koll, E. Reich, 2003).

In HPTLC, smaller (10 * 10 or 10 * 20) faster (7-20 minutes) analytical plates are used. The distance is usually 6 cm. For commercial densitometry measurement, HPTLC plates are used due to their higher resolution, robust detection, and excellent in situ

measurements. Optimizing and choosing the mobile phase. The adsorbent substance utilized as the stationary phase and the physical and chemical properties of the analyte are the main determinants in the choice of mobile phase.

- 4. Sample Preparation and Application:** A proper solvent system is one that alters the baseline position of every component of the combination while adding nothing to the solvent front. Between R_f 0.15 and 0.85, the peaks of interest must be resolved. Eluent strength, which is associated with the polarity of the mobile phase components, is a factor that affects the elution power of the mobile phase. More nonpolar compounds elute more quickly (or spend less time in the stationary phase), while more polar compounds elute more slowly (or spend more time in the stationary phase).
- 5. Chromatogram Development:** Although the chromatogram development stage is very important stage in the HTLC process, less important ones are often forgotten. HPTLC plates are produced in a horizontal expansion chamber (also known as a double-groove chamber). In general, a saturated dual-chamber chamber equipped with filter paper provides the best reproducibility. The use of double bypass prevents preloading of solvent vapors and moisture. Fluorescence quenching caused by UV radiation (usually emitted at wavelengths between 200 and 400 nm) improves the detection of chemicals separated from the adsorbent layer. Fluorescence quenching is the popular name for this phenomenon.
- 6. Pre-Wash:** The main purpose of prewash is to remove contaminants such as water vapor and other contaminants before they are exposed to the environment. Laboratory environment. The most commonly used adsorbent is Silica 60F. The main disadvantage of this adsorbent is the presence of metal impurities. These metals can be removed using a 9:1 methanol/water ratio. This is the main benefit of pre-cleaning. Various pre-washing methods
 - Ascending method
 - Descending method
 - Continuous method
- 7. Plate Activation:** The HPTLC plate box is automatically opened without needing to be opened. Plates that have been kept for a long time or exposed to excessive moisture need to be strengthened. Before using the samples, the plates were placed in an oven at 110 to 120°C for 30 minutes.
- 8. Pre-Processing:** Also called room saturation. High R_f value results from unsaturated rooms.
- 9. Application of Sample:** Can be used
 - Capillaries
 - Microsyringes
 - Microdevices for sample application pipettes
 - Autosamplers

10. Steps after Chromatography

- Detection
 - Photo data
 - Optical density measurement
- **Detection:** First, the selection of drugs that do not absorb UV, such as Bambutol is not harmful, dicycloamine etc. and then placed on the plate in 0.1% iodine solution under UV light.
- **Optical Density Measurement:** Measure fluorescence, UV absorbance or visibility. Create a chromatogram containing dotted peaks.

IV. HPTLC APPLICATIONS

- Pharmaceutical sector - quality control, identification, purity testing, etc.
- Food inspection – quality control, additives, pesticides, safety measures, etc.
- Medical applications – Metabolism research, drug screening, safety evaluation, etc. cosmetics, natural products such as hydrocortisone and cinchona in lanolin ointment, botanical ingredients - glycosides in herbs, piperine in mint, etc.
- Fingerprint - Licorice, ginseng etc. Used to identify fingerprints.
- Analysis of drugs in blood. (Parihar S 2022)

V. HIGH PERFORMANCE LIQUID CHROMATOGRAPHY

When separation using High Performance Liquid Chromatography (HPLC), the product must be separated into two immiscible phases. (J.M. Miller, 2005). These two levels are fixed level and mobile level (Z. Dicer, 2003).

The chromatographic process can be done in three different ways: elution, front face and displacement. Elution involves injecting or depositing a sample into the starting of the chromatography system. Suppose the system has one column. If so, the distribution of particles between the stationary phase and the cell determines how they are separated from the column (Qi. Meiling, Peng Wang 2004).

Concentration distributions are generally Gaussian and symmetric. Peaks appear when small samples are used (JL. Rafferty, 2008).

Efficiency is best in this case, so the sample volume is kept as small as possible while the liquid chromatograph is running at high speed. < br> As separation begins, many interactions will occur; these are called separations. The following are groups of interaction mechanisms:

- Adsorption
- Partition
- Bonded phase
- Ion exchange
- Size exclusion

- Affinity

- 1. Principle:** HPLC is a separation procedure that includes injecting a tiny quantity of liquid sample into a tube containing a small particle (3 to 5 microns (m) in diameter, known as the stationary phase), and transporting the individual particles of the sample into the packed package. The pressure supplied by the pump pushes liquid (mobile phase) out of the tube (column). Packaging lines that separate these products require chemical and/or physical interactions between product molecules and the packaging material. A flow meter (meter) to detect this separation is placed at the exit of the tube (column). "HPLC" is the output of this device. Although the functions of LC and HPLC are similar in theory, the speed, efficiency, sensitivity and ease of use of HPLC are superior (JJ. Berg, 1987).
- 2. Types:** The phase utilized in the procedure determines the kind of HPLC employed. The following HPLC methods were used for analysis:
- 3. Normal Phase Chromatography:** This method, also known as Normal Phase HPLC (NP-HPLC), separates by polarity. Polar stationary phase and non-polar mobile phase are utilized in NP-HPLC. The polar stationary phase interacts with and stores polar analytes. The interaction of polar analytes with the polar stationary phase increases the elution duration, and increasing the polarity leads to greater adsorption.
- 4. Reverse Phase Chromatography:** Reverse Phase RP-HPLC (or RPC) uses an aqueous, neutral polar mobile phase and a non-polar stationary phase. RPC is based on the concept of hydrophobic interaction caused by the strength of polar eluents, less polar analytes and non-polar stationary phase. The contact area formed by interaction with the ligand in the eluent surrounding the nonpolar region of the analyte molecule influences the analyte's affinity to the stationary phase.
- 5. Size Exclusion Chromatography:** SEC, also known as gel permeation chromatography or gel filtration chromatography, is a chromatography technology that separates materials primarily by size. It also aids in the understanding of the quaternary and tertiary structures of proteins and amino acids. This approach may be used to calculate the molecular weight of polysaccharides. (S.L. Abidi, 1991).
- 6. Ion Exchange Chromatography:** Selection of solvent ions and charged sites in the stationary phase to drive ion exchange chromatography. Excludes similar ions. This chromatography technique is commonly utilized in protein ion exchange chromatography, ligand exchange chromatography, and high pH anion exchange chromatography of carbohydrates and oligosaccharides., and other water purification processes (Hearn M.1980).
- 7. Bio affinity Chromatography:** Interactions between ligands and proteins are used to separate them. Bio affinity matrices are made consisting of ligands that are covalently linked to a support that immobilizes proteins that interact with the ligands on the side.

VI. INSTRUMENTATION

- Pump
- Injector
- Column
- Detector
- Recorder or data system

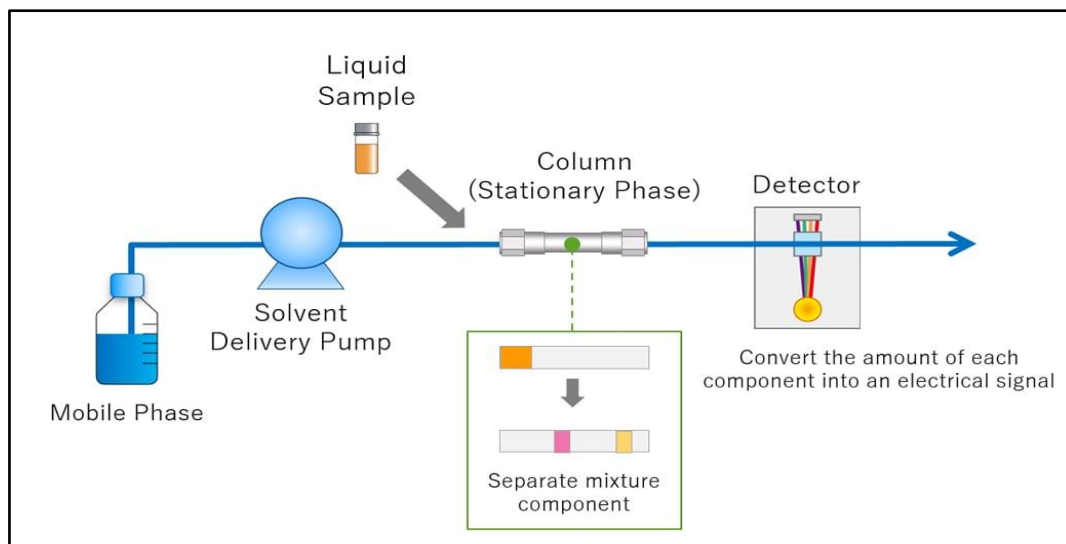

Figure 2: Instrumentation of High Performance Liquid Chromatography

- 1. Pump:** Compared to gravity flow chromatography, the pump increases the strength of the cell phase through the column. Even though the composition of the cells phases changes, the pump maintains stability and prevents respiration (MR. Euerby, 2003).
- 2. Syringe:** The syringe is used to inject the liquid. There are two types of syringes: automatic and manual.
- 3. Column:** The importance of the column should be explained as it is an important part of HPLC. The most widely used and widespread is silica (A. So, 2015).
- 4. Capture:** The HPLC analyzer continuously measures the eluent to give an electronic signal equal to each individual amount leaving the column (M. Dare, 2015).

The most commonly used equipment:

- Differential pressure detector
- Fluorescence detector
- Evaporative light scattering detector
- Conductivity detector

- 5. Data Recording:** After detection is completed, the detected signal is converted into an electrical signal, which is then emitted by the generator and recorded as a chromatogram

in the content file. The software is then used as a display format as a manual or automatic conversion model (N. Erk, 2003), (J. Lindholm, 2004).

HPLC development generally involves two main phases :< br>• Mobile phase
• Stationary phase.

6. Applications

- Analyze the composition and purification of compounds.
- Search for food and medicine.
- Detection of seized drugs
- Determination of the amount of drugs contained in new drugs.
- Pharmaceutical Applications
- Environmental Applications
- Forensic Medicine
- Clinical
- Immiscible phase separation in Food and Aroma Chromatography.

There is an equilibrium difference between two samples. One of the mobile phases is the mobile phase and the other is the stationary phase (L. Wang, 2007).

VII. COLUMN CHROMATOGRAPHY

- 1. Introduction:** Column chromatography is the most basic and commonly used separation and purification process. Column chromatography is a technique for separating and purifying liquids. In column chromatography, a stationary phase and a liquid mobile phase work together to adsorb and separate the product passing through it. Substances are adsorbed depending on their chemical makeup, and elution is dependent on the difference between the adsorbent's substances. varied stationary phases, such as silica, aluminum oxide, calcium phosphate, calcium carbonate, starch, and magnesium oxide, are employed individually in column chromatography, with varied solvent compositions depending on the kind of substance to be extracted. Separation of several drug classes in extracts necessitates careful optimization. A slurry (adsorbent) and a sufficient weight are put into a cylindrical glass tube whose bottom is sealed with glass wool or a porous disc in column chromatography. The silica-mixed sample is poured into the column and allowed to migrate with the solvent. Compounds are adsorbed in distinct locations and desorbed with suitable solvent polarity due to the change in polarity. The majority of adsorbing compounds will be towards the top, with the least adsorbing chemicals at the bottom. Elution is the process of desorbing chemicals and allowing them to flow through the column once the solvent reaches the head.
- 2. Principle:** The principle of column chromatography is adsorption. A component mixture is dissolved in the mobile phase and added to the column; the components then move in the sequence in which they were introduced. Components with lower adsorption and affinity to the stationary phase move quicker than components with higher adsorption and affinity. The process begins with removing fast motion, removing slow motion takes longer.

The classification depends on the polarity are as follows:

- **Normal Phase Chromatography (NPLC)**
- **Reversed-Phase Chromatography (RPLC)**

3. **Instrumentation:** The following are the components of a typical column chromatographic system employing a gas or liquid mobile phase:

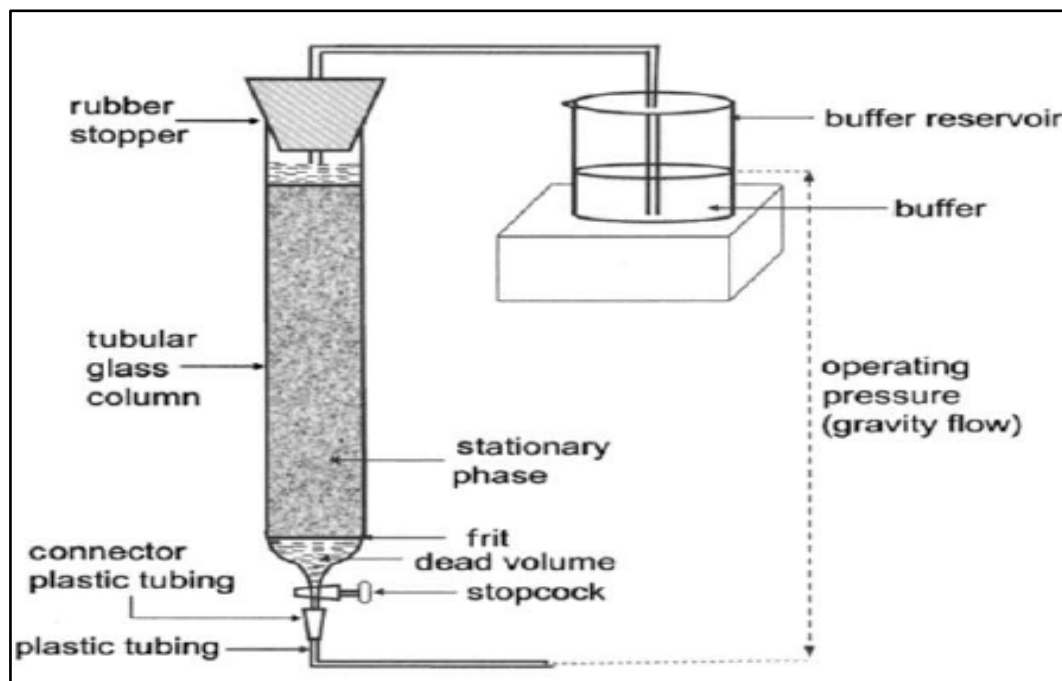

Figure 3: Instrumentation of Column Chromatography

4. **Stationary phase:** Select a suitable stationary phase for separation of analytes.
5. **Column:** The chromatographic column used for liquid chromatography is usually 25 to 50 cm long, 4 mm in diameter and made of stainless steel; Gas chromatograph made of glass or stainless steel. Both the stationary phase type and the microporous type where the stationary phase is coated directly on the inner wall of the receiving column.
6. **Mobile phase and DISTRIBUTION:** Choose to change the measurement model and enter in the constant flow rate column to add the mobile phase.
7. **Sampling System:** Send the sample to the top of the line in one go.
8. **Capture and Save:** To record continuous data for analytes as the eluent exits the column. Physical energy, such as visible or ultraviolet absorption or fluorescence, is often measured for detection purposes. The peak for each different measurement will appear in the list.

9. Fraction Collector: Used to collect individual analytes for further biochemical studies (K. Wilson, 2018).

10. Applications

- **Clinical Use:** For clinical use, use capillary tubes made of glass or copper with a diameter of 0.05-2 mm and a length of 1-20 m. The inside of the narrow tube acts as a support or adsorbent for the liquid phase. Methyl ketone/pyridine/dilute acetic acid (5:5:1) or butanone/acetic acid/water (3:1:6) can be used to separate amino acid C in a 300° strong glass capillary and Ammonia water. Researchers Vestergaard and Sayegh separated seven urinary steroids in 5 hours compared to 36 hours using column chromatography. They use Teflon tubes containing silicon or aluminum oxide. Optical detector for gradient elution analysis of steroids in chloroform and acetone.
- **Separation of Diastereomers:** Separation of diastereoisomers 7-chloro-azidebicyclo (4:1:0)-heptane was carried out on silica gel using pentane/diethyl ether as solvent. 3. Separation of tautomer mixture: Separation of tautomer mixture can be done at high temperature but not by gas chromatography. However, column chromatography can be used to separate them. P-Hydroxy-phenylpyruvate, indolepyruvate and their ketone and enol derivatives can be separated in the liquid phase. Use a weakly acidic medium for separation. The enol form is present in the eluate before the keto form.
- **Separation of Geometric Isomers:** separation of cis and trans isomers depending on the compound. Isomers with functional groups can easily access the adsorbent surface to form strong adsorption. Scientist Winterstein reported for the first time the chromatographic separation of cis and trans isomers of bixin and dimethyl crocetin. Later, Zechmeister used adsorbents such as calcium carbonate and alumina to separate the cis and trans isomers of carotenoids. Cis and trans isomers of carboxylic acids were distinguished from coal and silica.
- **Separation of Racemate:** For the first time, organic solvents were used to completely separate the lactose racemate.

VIII. PAPER CHROMATOGRAPHY

- 1. Introduction:** Synge and Martin discovered paper chromatography in 1943. Paper chromatography is a unique technology that makes use of a certain type of paper. It is a type of planar chromatography in which cellulose-based filter paper is employed as the stationary phase to separate items. The process is inexpensive and helps separate chemicals based on their different movements in the paper. This method requires only a small sample size for analysis (N. W. Eigsti, 1967).
- 2. Principle:** The main point behind paper chromatography is to split the difference between different substances or separate the liquid phase. It uses an aqueous solvent that is stored in the pores of the filter paper and acts as a stationary phase during movement through the filter paper (O. Coşkun, 2016). Separation occurs by capillary action in the paper pores due to the difference in the concentration of particles in the water mixture (stationary

solvent) and the mobile phase solvent. The principle of adsorption between solid phase and liquid phase can also be used to separate particles, where the stationary phase is the heavy liquid and the mobile phase is the material of the paper. Although classification is the primary method of paper chromatography, it is also used in other medical applications.

3. **Procedure:** The fundamental process for doing paper chromatography is described here:

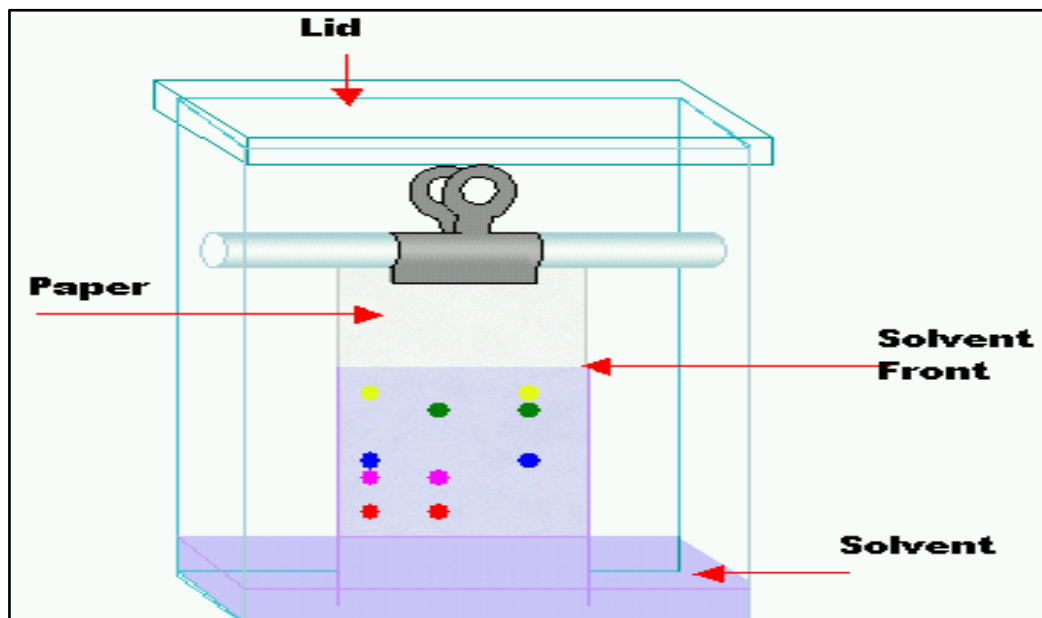

Figure 4: Instrumentation of Paper Chromatography

4. **Select the Appropriate Type of Development:** Difficulty of the solvent, type of paper used, nature of the sample, etc. Choose the type of development based on factors such as. Radial chromatography is often chosen for its ease of use and high resolution. Also, it takes less time to complete and achieve results.
5. **Choose the Right Filter Paper:** You can choose the right filter paper by looking at its quality and pore size. Whatmann No.1 filter paper is usually used as a thin layer.
6. **Prepare the Sample:** Prepare the sample by dissolving it to an appropriate weight. Usually used as the mobile phase, it must be inert to the material being analyzed.
7. **See the Sample on Paper:** The sample should be placed in the center of the paper using a capillary tube and placed in the correct position.
8. **Chromatogram Development:** Mobile phase is used to develop chromatogram on paper. As the mobile phase is drawn into the filter by capillary action, the components of the sample begin to move according to their affinity for the mobile phase.

9. Drying and Scientific Analysis of Paper: Dry the paper at room temperature and then with a dryer after seeing the chromatogram. These substances are chemically identified using antibodies (SK Pramod, 2017).

10. Application

- Paper chromatography is a useful method for determining the amount of material present in a sample using a mobile selective phase.
- This method requires a small setup, including small samples, and is still very effective (V. Jirgl, 1957).
- Paper chromatography is an effective method for separating free amino acids in human blood. (J. Awapara, 1949).
- It also provides a method for rapid separation and estimation of sugar; however, identification depends on the determination of their physical regularity and the formation of characteristic derivatives (L. Hough, 1950).
- In addition, combinations of phenylephrine hydrochloride, chlorpheniramine hydrochloride, and dextromethorphan hydrochloride are used in paper chromatography. (H. Schriftmann, 1961).
- Using two-sheet chromatography, this approach may also be utilized to separate a pair of components with identical RF values.
- Paper chromatography is also used in low-level applications such as the separation of cations including cadmium, zinc, mercury, beryllium, and calcium. (D. Clegg, 1950).
- This method also helps to identify accelerators and antioxidants in rubber and determine their quality (J. Zijp, 1956).
- Paper chromatography is mostly used in the study of various plants such as opium and quinine alkaloids (M. Rasul, 2011).
- Paper chromatography is also used to determine the rate of reaction constants. Therefore, it is an important component of synthetic materials (D. Peterson, 1950).

IX. GAS CHROMATOGRAPHY

1. Introduction: One of the best methods for the separation and analysis of petroleum products and impurities is gas chromatography. James and Martin invented the modern gas chromatograph in 1952. Since the early 1950s, this approach has been used to separate amino acids.. But today GC has many uses due to its speed and sensitivity. GC may be used to measure both qualitative and quantitative data. GC is capable of analyzing small samples. The sample is dissolved in a solvent and evaporated to separate analytes in gas chromatography. Stationary phase and mobile phase separate the model into two parts. The phase of the cell contains inert gases such as helium, nitrogen or other gases. A special type of chromatography is gas chromatography, which does not require mobile time to interact with the analyte. The stationary phase in gas-solid chromatography (GSC) is the adsorbent, whereas the stationary phase in gas-liquid chromatography (GLC) is the liquid on the inert support. Volatility and thermal stability are poor choices for chemicals to be analyzed in GC.

2. Principle: Gas-solid chromatography uses a stationary phase made of adsorbents to achieve separation by the adsorption process, while gas-liquid chromatography uses a

separate layer of non-volatile liquids along with solids. Support is provided by the separation and classification process. The most commonly used technique is gas chromatography. The sample must be separated before evaporation and then mixed with the gas flow. More soluble components in the sample move more slowly through the stationary phase, while less soluble components move faster. Therefore, the components are divided according to their distribution coefficients.

3. **Instrumentation:** In general, all chromatographs (GSC or GLC) are made up of six main components:

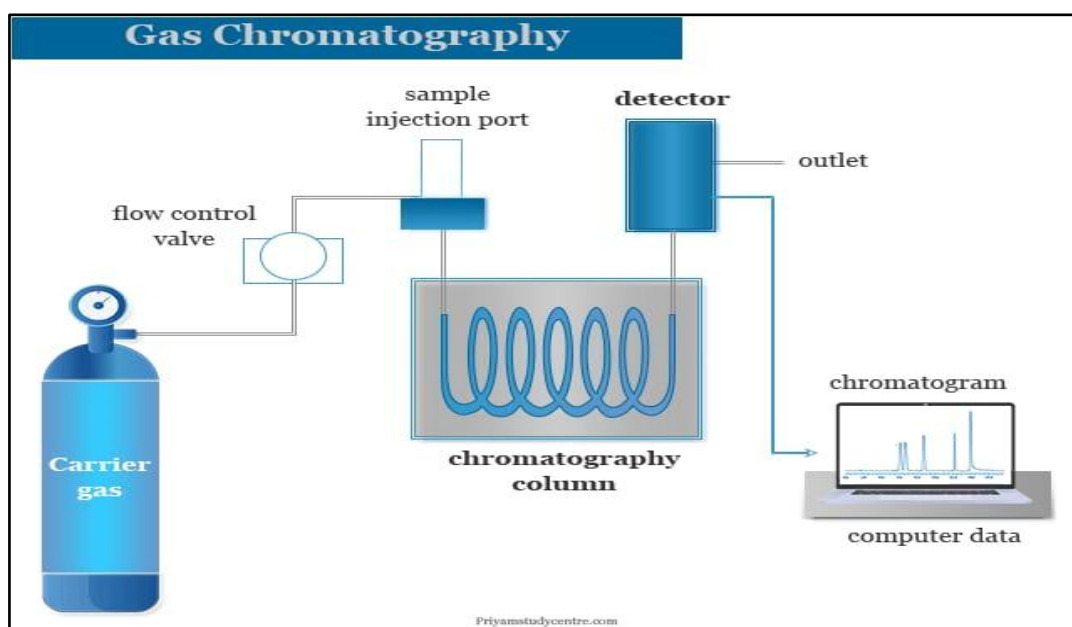

Figure 5: Instrumentation of Gas Chromatography

4. **Sample Injection:** A sample port is required to add samples to the top of the column. Use a calibrated microsyringe to inject an aliquot of sample into the evaporation chamber through the rubber septum. Sample splitters are used to introduce additional samples into the bin because most splits require only a small portion of the original sample. In commercial gas chromatographs, packed and capillary columns switch between split and unsplit injection. To transport the sample to the column, the evaporation chamber is heated to a temperature usually 50°C above the sample temperature.
5. **Carrier Gas:** Carrier gas is required for GC. It should be dry, inert and oxygen-free. Depending on the tool used and efficiency, helium, nitrogen, argon and hydrogen can be used as carbon monoxide. Carbon monoxide is removed by high pressure and sent to the meter quickly and continuously.
6. **Separation Columns:** Open tube, capillary and packed columns are used in gas chromatography. Wall-lined open pipe (WCOT) lines and support-covered open pipe (SCOT) lines are two types of capillary lines. A thin layer of stationary phase is applied to the WCOT column's walls. A thin coating of adsorbent material (such as diatomaceous earth, derived from the single-celled shells of marine plants) is initially deposited on the

wall of a SCOT column. The fixed liquid is then used to treat the adsorbent. Due to the larger capacity, the SCOT line may have a more stable phase than the WCOT line, but the overall performance of the WCOT line is still better. Coated fused silica open tubular lines are one of the most commonly used types of capillary lines.

- 7. Column Thermostat or Thermostat:** The purpose of the thermostat is to control the temperature of the side for efficient operation. There are two control methods for the oven: isothermal programming and temperature programming. During separation, the temperature of the column is kept constant in the isothermal procedure. The temperature of the column increases constantly or gradually as the separation advances in the temperature programmed technique.
- 8. Detector:** Mass spectrometer, flame ionization detector (FID), electron capture detector (ECD), thermal conductivity detector (TCD), atomic emission detector (AED), photoionization detector (PID), and chemiluminescence detection GC are the most common types of equipment. As the compounds separate and combine with the carrier gas, they are measured quantitatively by a detector at the bottom of the column.
- 9. Amplification and Recording Systems:** These are the last and most important GC tools. These are designed to detect signals sent by detectors. These use specialized electronic equipment to analyze and present the signal, displaying the various peaks of the sample in an easy-to-understand graphical representation. To disperse carbon monoxide at a constant pressure and flow rate, the GC is also equipped with a flow meter and indicator.

10. Application

- Identification of harmful substances in wastewater.
- Identification of drugs and their metabolites in blood and urine for medical and research purposes.
- Identification of vaccine products.
- Measurement of contaminants in drinking water and wastewater.
- Product inspection for quality control.
- Skin examination.
- RNA isolation.
- Astronomical and Geochemical Search (AG. Linde, 2012).

X. ION EXCHANGE CHROMATOGRAPHY

- 1. Introduction:** This can be done by separating any electronic products such as proteins, amino acids or small nucleotides using ion exchange chromatography. The injected solution is called the sample, and the separated solution is called the test solution. This method is used in water filtration, analysis and quality control. It offers more options due to the intensive use of mobile and station connections. Stationary products are called ion exchangers and can reversibly remove ions from a solution while replacing them with equivalent ions. Ion exchange chromatography is the most flexible of all methods and is a useful tool for separating ions that have comparable properties but are difficult to identify.

It helps in the separation of organic acids, amino acids, peptides and nucleotides and in finding complex mixtures of rare related individuals (M. Singh, 2003).

- 2. Principle:** It is based on the attraction of different substances. For example, consider proteins and amino acids, which can have a positive or negative valence and are used to separate compounds of these substances. Henderson Hesselbalch's equation shows that the value of these substances depends on the pKa and pH of the solution (GR. Chatwal, 2007).

In ion exchange chromatography, retention of analytes on the column is based on ionic contact. Ionic functional group R-X interacts with oppositely charged analyte ions and is present in the stationary phase.

For this reason, ion exchange chromatography is divided into two groups.

- Cation ion exchange chromatography.
- Anion ion exchange chromatography.

The anionic substance B⁻ and the cationic substance M⁺ form an ionic compound and can be maintained in a stable state.

Since stationary phases display negative functional groups, cation ion exchange chromatography collects positive cations.

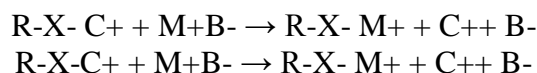

Using positive functional groups, anion exchange chromatography: collects: anions.

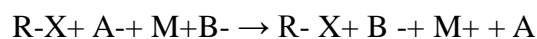

3. Instrumentation

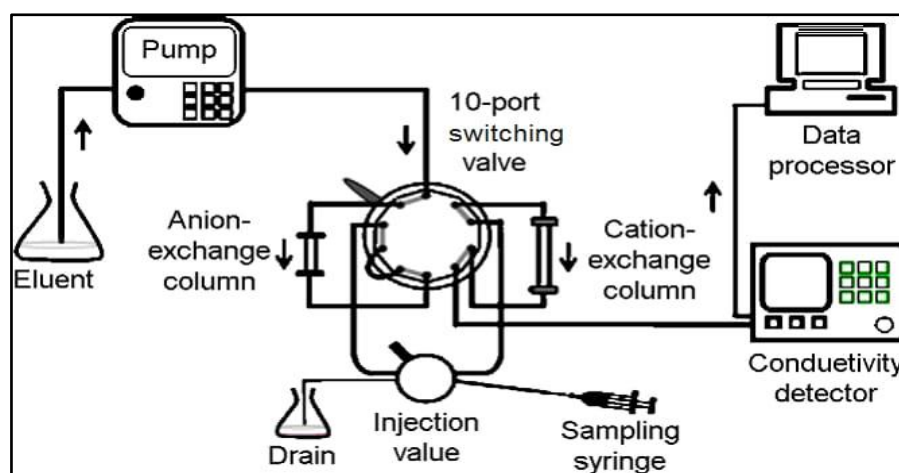

Figure 6: Instrumentation of Ion- Exchange Chromatography

- High pressure pump with pressure and flow meters to deliver the eluent.
- In order to insert the sample into the eluent stream and the column, an injector is employed.
- The sample mixture is separated into its constituents using a column.
- Capture is used to capture eluents from the chromatographic column measure analyte peaks
- Data used to write and edit chromatograms and data

4. **Chromatography Column:** Industrial chromatography columns are usually made of stainless steel or polymers resistant to acids and alkalis, while the test column is made of glass.

Separation coefficient has nothing to do with column performance and shape. A better separation can be achieved by widening the column, but not beyond a significant length. If the length of the line is too wide or too narrow, the balance of the fluid will not be achieved. Line sizes from 20:1 to 100:1 can be used for better performance.

5. **Packaging of the Column:** In this case, wet packaging of the column is used. In the column, the mobile phase is combined with the resin and equilibrated. Once the sample is dissolved in the mobile phase, it is deposited in the column.
6. **Application of the Sample:** Pack the solution to be tested and place it on the top of the column and then allow it to pass through the ion exchange bed. A syringe or pipette is used for this purpose.
7. **Mobile Phase:** Organic solvents are less effective as they are no longer used. Only acids, bases and buffers of various strengths are used as elution solvents.
8. **Development of Chromatograms and Elutions:** After introduction, chromatograms were developed using various mobile moments. Make the ionic strength the same in salt solution. The choice of resin for solvent ions determines which time to use.

There are two different elution methods:

- Isocratic elution
- Gradient Elution

9. **Regeneration of Ion Exchange Resin:** After separation, the ion exchange resin is unsuitable for subsequent separation because its exchange function is eliminated. However, ion exchange resin cannot be discarded due to its high cost. Therefore, reactivation and regeneration of the resin is very important. The performance of ion exchange resin through regeneration is comparable to the new product.

The term "regeneration" describes the exchange of cations or anions of a resin. As a result, the column must be filled with a strong acid, such as hydrochloric acid, in order to make cation exchange resin. To renew anion exchange resins, strong bases such as sodium hydroxide or potassium hydroxide are needed.

10. Application

- It removes monovalent and divalent ions such as sodium, potassium, calcium and magnesium from water.
- Softened water is obtained by removing various ions, also known as deionization. Ionic contaminants are removed from solution by purification.
- Separate cationic and anionic inorganic ions.
- Organic Isolates: Most organic compounds have strongly acidic or weak properties. Therefore, mixtures of compounds can be separated using ion exchange resins. Classes of isolable compounds include amino acids, proteins, antibiotics, vitamins, fatty acids, etc. is available. (J. Mendham, 2017).

REFERENCES

- [1] Jeanes, C. Wise, and R.-J. Dimler, "Improved techniques in paper chromatography of carbohydrates," *Analytical Chemistry*, vol. 23, no. 3, pp. 415-420. 1951.
- [2] Abidi, S.L. High-performance liquid chromatography of phosphatidic acids and related polar lipids. *J. Chromatogr.* 1991; 587: 193-203.
- [3] Anees A. Siddiqui; *Pharmaceutical Analysis*; volume-I; page. No: 216 – 236.
- [4] Aryal, S., HARINKHEDE, P., ΖΗΓΛΙΣ, Ν. Δ. Τ. Σ., PM, I. G., Singh, M., Bakhtawar, Singh, D. S. (2021, July 26). Chromatography- definition, principle, types, applications. Retrieved October 23, 2021, from <https://microbenotes.com/chromatography-principle-types-and-applications>.
- [5] Bergh JJ, Breytenbach JC. Stability-indicating high-performance liquid chromatographic analysis of trimethoprim in pharmaceuticals. *J Chromatogr.* 1987 Jan 30; 387:528-31. doi: 10.1016/s0021-9673(01)94565-0. PMID: 3558640
- [6] Chatwal GR, and Anand SK. *Instrumental Methods of Chemical Analysis*. Himalaya Publishing House Mumbai. 2007, 2.662-2.672
- [7] Chromatography, classification, principle of working and selected techniques. Retrieved October 23, 2021, from <https://www.scribd.com/document/178065088/Chromatography-ClassificationPrinciple-of-Working-and-Selected-Techniques>
- [8] Chromatography, K. (2018). Review Article: Chromatography Principle and Applications.
- [9] D. H. Peterson, and L. M. Reineke, "A paper chromatographic technique and its application to the study of new antibiotics," *Journal of the American Chemical Society*, vol. 72, no. 8, pp. 3598-3603. 1950
- [10] D. L. Clegg, "Paper chromatography," *Analytical Chemistry*, vol. 22, no. 1, pp. 48-59. 1950
- [11] Dare M, Jain R, Pandey A. Method validation for stability indicating method of related substance in active pharmaceutical ingredients dabigatran etexilate mesylate by reverse phase chromatography. *J Chromatogr A.* 2015;6(2); 263.
- [12] Dincer Z, Basan H, Goger NG. Quantitative determination of ambroxol in tablets by derivative UV spectrophotometric method and HPLC. *J Pharm Biomed Anal.* 2003; 31 (5):867-72.
- [13] Dr. A. V. Kasture, Dr. K. R. Mahadik, Dr. S. G. Wadodkar, Dr. H. N. More; *Pharmaceutical Analysis*; volume-II; page. No: 39 – 47.
- [14] Erk N. Rapid and sensitive HPLC method for the simultaneous determination of dorzolamide hydrochloride and timolol maleate in eye drops with diode-array and UV detection. *Pharmazie.* 2003 Jul; 58(7):491-493.
- [15] Euerby MR, Petersson P. Chromatographic classification and comparison of commercially available reversed-phase liquid chromatographic columns using principal component analysis. *J Chromatogr.* 2003; 994(1-2):13-36.
- [16] F. Kurzer, "An early application of paper chromatography," *Journal of Chemical Education*, vol. 55, no. 5, pp. 321, 1978/05/01. 1978.
- [17] G. Devala Rao; *A Text Book of Pharmaceutical Analysis*; volume-II; page. No: 54 – 57.
- [18] G. Zweig, and J. Sherma, "Paper Chromatography—Past, Present and Future," *Journal of Chromatographic Science*, vol. 11, no. 6, pp. 279-283. 1973.
- [19] Gurdeep R. Chatwal, Sham K. Anand; *Instrumental Methods of Chemical Analysis*; page. No: 2.662-2.672.

IDENTIFICATION OF DRUGS IN DIFFERENT PHARMACEUTICAL PREPARATIONS USING CHROMATOGRAPHIC TECHNIQUES

- [20] H. G. Cassidy, "Investigation of paper chromatography," *Analytical Chemistry*, vol. 24, no. 9, pp. 1415-1421.
- [21] H. Schriftman, and R. C. Shultz, "Application of paper chromatography and electrophoresis to the assay of pharmaceutical products," *Journal of pharmaceutical sciences*, vol. 50, no. 4, pp. 332-336. 1961.
- [22] Hearn M.T.W. Ion-pair chromatography on normal and reversed-phase systems. *Adv. Chromatography*. 1980; 18: 59–100.
- [23] Hostettmann, K., Marston, A., & Hostettmann, M. (2011). *Preparative Chromatography Techniques: Applications in natural product isolation*. Berlin: Springer.
- [24] [https://chem.libretexts.org/Textbook_Maps/Analytical_Chemistry/Supplemental_Modules\(AAnalytical_Chemistry\)/Instrumental_Analysis/Chromatography/Gas_Chromatograph](https://chem.libretexts.org/Textbook_Maps/Analytical_Chemistry/Supplemental_Modules(AAnalytical_Chemistry)/Instrumental_Analysis/Chromatography/Gas_Chromatograph).
- [25] <https://www.omicsonline.org/development-and-validation-of-a-gas-chromatographymass-spectrometry-method-for-the-determination-of-pcbs-in-transformer-oil-samplesapplication-on-real-samples-from-botswana-2157-7064.1000116.php?aid=3620>
- [26] <https://www.omicsonline.org/method-validation-for-the-trace-analysis-of-geosmin-and-2-methylisoborneol%20in-water-by-salt-free-purge-and-trap-sampling-gc-ms-using-theeclipse-4660-sample-concentrator-2157-7587.1000134.php?aid=749>
- [27] <https://www.sigmaaldrich.com/life-science/ascentis>
- [28] <https://www.slideshare.net/shaisejacob/column-chromato>
- [29] J. Awapara, "Application of paper chromatography to the estimation of some free amino acids in tissues of the rat," *Journal of Biological Chemistry*, vol. 178, pp. 113-116. 1949.
- [30] J. Mendham, R.C Denney, J.D Barnes, M. Thomas, B. Siva Sankar; *Text Book of Quantitative Chemical Analysis*, 6th edition; page. No: 213-222.
- [31] J. Sherma, *Modern thin-layer chromatography*, *Journal of AOAC International*, Vol.91, No.5, 2008, pp. 1142-1144.
- [32] J. Zijp, "Application of paper chromatography to the identification of accelerators and antioxidants: IV. Detection of antioxidants," *Recueil des Travaux Chimiques des Pays-Bas*, vol. 75, no. 10, pp. 1129-1136. 1956
- [33] K. Ferenczi-Fodor, Z. Végh, A. Nagy-Turák, B. Renger, and M. Zeller, Validation and quality assurance of planar chromatographic procedures in pharmaceutical analysis, *Journal of AOAC International*, Vol.84, No.4, 2001, pp. 1265-1276.
- [34] Koll K., Reich E., Blatter A., Veit M. Validation of standardized high-performance thin-layer chromatographic methods for quality control and stability testing of herbals. *J. AOAC Int.* 2003; 86: 909-915.
- [35] L. Hough, "Application of paper partition chromatography to the separation of the polyhydric alcohols," *Nature*, vol. 165, no. 4193, pp. 400-400. 1950.
- [36] Linde AG. *Gas Chromatography*. Archived from the original on 3 March 2012. Retrieved 11 March 2012.
- [37] Lindholm J. Development and Validation of HPLC Method for Analytical and Preparative Purpose, *Acta Universitatis Upsaliensis Uppsala* 2004; 13-14.
- [38] Luxminarayan L, Sharma N, Viswas A, Khinchi MP. A review on chromatography techniques. *Asian Journal of Pharmaceutical Research and Development*. 2017 Mar 1:1-08.
- [39] M. G. Rasul, "Extraction, Isolation and Characterization of Natural Products from Medicinal Plants," *International Journal of Basic Sciences and Applied Computing*, vol. 2, no. 6, pp. 1-6. 2011
- [40] McMurry, J. (2015). *Organic Chemistry with biological applications*. Stamford, CT: Gengage Learning.
- [41] McNaught, A. D., & Wilkinson, A. (1997). *Compendium of chemical terminology*. Blackwell Scientific.
- [42] Meiling Qi, Peng Wang, Ruihua Cong, Jianjun Yang. Simultaneous determination of roxithromycin and ambroxol hydrochloride in a new tablet formulation by liquid chromatography. *J Pharm Biomed Anal.* 2004; 35(5):1287-91.
- [43] Miller JM. *Chromatography concepts and contrasts*. 2nd Ed. New Jersey. 2005:35-182
- [44] Nielsen, S. S. (2010). *Food analysis*. New York: Springer.
- [45] O. Coskun, "Separation techniques: chromatography," *Northern clinics of Istanbul*, vol. 3, no. 2, pp. 156. 2016
- [46] P. A. Little, and J. A. Schleimer, "Application of Paper Chromatography to Oil Field Problems."
- [47] P. Parimoo; *Pharmaceutical Analysis*; page. No: 284 - 286.
- [48] Parihar S, Hooda S, Kakkar S, Bhan M. A Review on High Performance Thin Layer Chromatography Methods and Validation Parameters for Quantification of Andrographolide from *Andrographis paniculata* and Its Marketed Formulations. *Sch Acad J Pharm.* 2022 Jan; 1:27-36.
- [49] R. A. Day, A. L. Underwood; *Quantitative Analysis*; 6th edition; page. No: 535-543.

IDENTIFICATION OF DRUGS IN DIFFERENT PHARMACEUTICAL PREPARATIONS USING CHROMATOGRAPHIC TECHNIQUES

- [50] Rafferty JL, Siepmann JI Schure MR. Molecular-level comparison of alkylsilane and polar-embedded reversed-phase liquid chromatography systems. *Anal Chem.* 2008; 80(16):6214-221.
- [51] S. K. Pramod, and K. A. Navnath, "A BRIEF REVIEW ON ULTRA PERFORMANCE LIQUID CHROMATOGRAPHY." 2017.
- [52] Singh M, *Analytical Chemistry Instrumental Technique.* Dominent Publisher and Distributer Delhi. 2003, 40- 51.
- [53] The Nobel Prize in chemistry 1952. Retrieved October 23, 2021, from <https://www.nobelprize.org/prizes/chemistry/1952/summary/>
- [54] Turker AR. Separation, Preconcentration and speciation of metal ions using solid phase extraction. *Sep Purification Rev.* 2012;41(3);169-206
- [55] Tyagi A, Nitin Sharma, Mittal K, Mashru R, Bhardwaj T, Malik J. HPTLC-densitometric and RP-HPLC method development and validation for determination of salbutamol sulphate, bromhexine hydrochloride and etofylline in tablet dosage forms. *Pharmaceutica Analytica Acta.* 2015; 6(3):350.
- [56] V. Jirgl, "Paper chromatography of free amino acids in blood serum," *Clinical chemistry*, vol. 3, pp. 154-155. 1957.
- [57] W. Eigsti, "Paper Chromatography for Student Research," *The American Biology Teacher*, pp. 123-134. 1967.
- [58] Wang L, Jiang G, Cai Y, He B, Wang Y, Shen D. Cloud point extraction coupled with HPLC-UV for the determination of phthalate esters in environmental water samples. *J Environ Sci.* 2007;19(7); 874-78.
- [59] Wang LL, Wang JQ, Zheng ZX, Xiao P. Cloud point extraction combined with high-performance liquid chromatography for speciation of chromium (III) and chromium (VI) in environmental sediment samples. *J Hazard Mater.* 2010;177(1-3); 114-18.
- [60] Wang P, Zhao G, Tian J, Su X. High-performance liquid chromatography inductively coupled plasma mass spectrometry-based method for the determination of organic arsenic feed additives and speciation of anionic arsenics in animal feed. *J Agric Food Chem.* 2010;58(9);5263-5270
- [61] Wilson, K., Walker, J. (2018). *Principles and Techniques of Biochemistry and Molecular Biology* (8 Eds.). Cambridge University Press: New York.
- [62] Yasser M. Moustafa and Rania E. Morsi; *Ion Exchange Chromatography - An Overview.*