

IOT-ENABLED SMART MONITORING AND CLEANING TECHNIQUES FOR ENHANCEMENT OF SOLAR PANEL EFFICIENCY

Abstract

The rapid adoption of solar energy as a clean and sustainable power source has led to an increased deployment of solar panel installations worldwide. However, solar panels' efficiency is affected by various factors including dust accumulation, shading and malfunctioning cells. To address these challenges and optimize solar panel performance, this research focuses on the development of an IoT-enabled Smart Monitoring and Cleaning System. The proposed system integrates Internet of Things (IoT) technology with advanced monitoring sensors to continuously collect real-time data on the performance and health of solar panels. The system incorporates smart cleaning techniques. Traditional solar panel cleaning methods can be costly and time-consuming. Therefore, this research explores the integration of automated cleaning mechanisms such as robotic cleaners or self-cleaning coatings. These techniques can efficiently remove dust and debris, mitigating the adverse effects of soiling on solar panel efficiency. The benefits of the proposed IoT-enabled Smart Monitoring and Cleaning System are twofold: First, it optimizes solar panel efficiency, leading to increased energy generation and improved financial returns on investments. Second, it reduces the environmental impact by promoting the use of renewable energy and minimizing water consumption, as the automated cleaning methods do not rely on water-intensive processes.

Keywords: Solar Panel, IoT- Real Time Monitoring, Cleaning, Techniques, Efficiency, Maintenance, Performance Parameters.

Authors

Akriti Garg

Research Scholar
Department of Electrical Engineering,
MJP Rohilkhand University
Bareilly, Uttar Pradesh, India.
akritistudy@gmail.com

Atul Sarojwal

Assistant Professor
Department of Electrical Engineering
MJP Rohilkhand University
Bareilly, Uttar Pradesh, India.

I. INTRODUCTION

1. Solar Panel: Solar panels, often called "PV panels," are devices designed to convert sunlight, composed of energy particles known as "photons," into electrical power that can be harnessed for various applications. Apart from generating electricity for homes and businesses through solar power systems, solar panels have versatile uses, including providing energy for off-grid cabins, powering telecommunications gear, supporting remote sensing technologies, and serving numerous other functions. The efficiency varies between different panel types but generally ranges from 15% to 20% for most commercial panels [1]. Solar panels are usually mounted on rooftops, ground-mounted racks, or integrated into building facades. They require a location with ample sunlight exposure to maximize energy production. The cost of solar panels has been declining over the years, making solar energy more accessible to homeowners and businesses. Government incentives and tax credits in some regions can further reduce the upfront costs. Solar panels are generally low-maintenance. Regular cleaning and occasional inspection for damage or debris are recommended to ensure optimal performance [2].

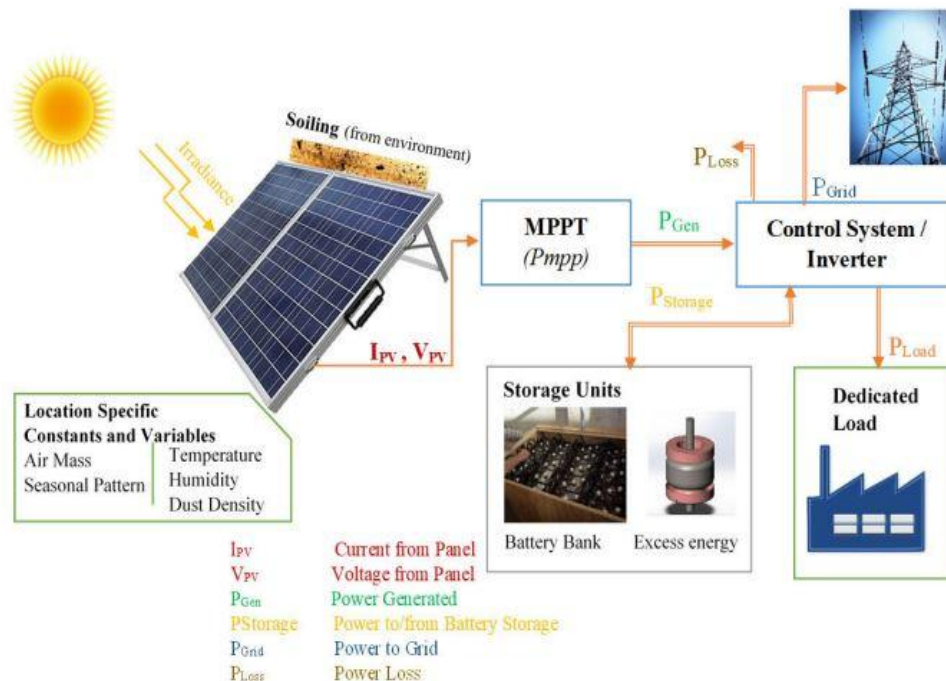

Figure1: Typical Solar PV System Block Diagram

2. Types of Solar Panel

- **Monocrystalline Photovoltaic Panels (Mono-PV):** Monocrystalline solar panels are commonly chosen for larger energy systems found in both commercial and residential structures. However, it's worth noting that these panels come in various sizes, making them suitable for smaller-scale installations as well. This means that monocrystalline panels can also be utilized in smaller energy setups.

Advantages

- Silicon is used in their construction, and it has a high purity rating, increasing their efficiency to 15% to 22%.
- Take up less room than thin-film and polycrystalline panels.
- Due to the steady and inert nature of silicon, monocrystalline panels can last up to 25 years.

Disadvantages

- Their cost is relatively high because of their complex design, and they may not be advisable for regions with cold climates as snowfall could potentially damage the solar cells and result in system malfunctions.
- Monocrystalline panels are rigid and lack flexibility, which can limit their applications in certain situations where flexible or curved solar panels are required.

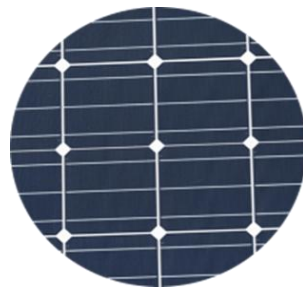

Figure 2: Single-crystalline Solar Panel

- **Polycrystalline Solar Panels (Poly-SI):** Polycrystalline solar panels are produced by fusing multiple pure silicon crystals together, but having a greater number of crystals doesn't always translate to superior performance. In fact, these panels tend to be less efficient compared to their monocrystalline counterparts. However, what makes them attractive is their versatility, as they come in various power capacities ranging from 5W to 250W and beyond. This makes them a suitable option for both small-scale and large-scale solar installations.

Advantages

- Because of the simpler manufacturing process, they are less expensive than monocrystalline.
- They are more environmentally friendly since they produce less waste during the melting process.

Disadvantages

- Because the silicon used to build them is less pure, they have poorer efficiency (13% to 17%)
- They require more space to produce the same amount of electricity as monocrystalline cells.

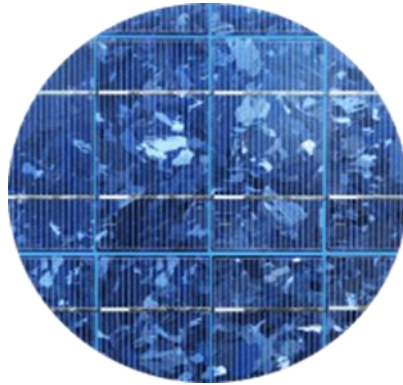

Figure 3: Polycrystalline Solar Panel

- **Recommended for Using in Transportation:** Thin-Film despite being portable and lightweight, thin-film PV cells that are not silicon-based are the least effective kind of solar panel. Use them only in installations where they won't need to generate a lot of power; their flexibility and portability are their two main advantages.

Advantages

- Easy and inexpensive to construct
- Perfect for solar-powered transportation applications, such as bus rooftop panels and cold-storage trucks.

Disadvantages

- Not ideal for rooftops due to their substantial space requirements in order to generate sufficient solar energy for power production.
- They are weaker and degrade more quickly than crystalline panels. For thin-film panel installations, there are only limited warranties available, which homeowners should take into account depending on how long they intend to live in their houses. 7% to 18% efficiency.



Figure 4: Thin Film Solar Panel

- **Amorphous silicon solar cell:** A-Si amorphous silicon solar cells, commonly found in pocket calculators, utilize a specific thin-film technology featuring three distinct layers. To provide a sense of their thinness, these cells measure just 1 micrometre, or one millionth of a meter, in thickness. While these cells are less efficient compared to

crystalline silicon solar cells, boasting an efficiency rate of only 7% versus the latter's 18%, their affordability sets them apart as a cost-effective option.

- **CdTe: Cadmium Telluride Solar Cell:** This particular photovoltaic technology relies on cadmium telluride, enabling the creation of cost-effective solar cells that offer a relatively short payback period, often less than a year. Among the various types of solar panels available, these stand out for their efficiency in water usage during production, making them an eco-friendly choice. CdTe solar cells are prized for their quick energy payback, resulting in a minimal carbon footprint. However, it's essential to acknowledge the drawback associated with cadmium telluride: it is toxic if ingested or inhaled. This toxicity remains a significant challenge to address, particularly in regions like Europe, where there is substantial hesitation about adopting this technology for solar panels.
- **HCVP and CVP Concentrated PV Cell:** Concentrated photovoltaic (CVP) cells generate electricity using the same principles as traditional solar systems. These advanced solar panels, known for their remarkable efficiency, can reach up to 41%. They derive their name from the specialized features that set them apart from other solar panel types, such as curved mirror surfaces, lenses, and sometimes even cooling systems. These elements work together to concentrate sunlight and enhance overall performance. Consequently, CVP cells have emerged as some of the most efficient solar panels available. However, it's important to note that CVP solar panels can only achieve their maximum effectiveness when they are oriented at the optimal angle towards the sun.

II. APPROACHES EMPLOYED TO ENHANCE SOLAR PANEL EFFICIENCY

1. **Hand-Cleaning Approach:** This method involves the hands-on cleaning of solar panels by a human operator who utilizes appropriate cleaning tools, as shown in Figure 5. The operator visually assesses the cleanliness of the panel's surface and continues cleaning until it meets the desired standards or until all dust and debris are removed. Solar power plants typically consist of multiple panels installed at heights ranging from 12 to 20 feet or even higher above the ground. This makes the cleaning process extremely time-consuming and challenging. It poses risks to both the required cleaning time and the safety of the personnel involved.

Manual cleaning of solar panels often involves the use of cleaning fluids like cleansers or gels, which can reduce surface transparency if not applied correctly. Additionally, photovoltaic (PV) panels are vulnerable to physical damage that cannot always be prevented during manual cleaning. To aid in the proper cleaning of solar panels, several useful tools can be employed. Specialized rotating brushes are commonly used to remove dirt and grime from the panel's surface. Simple cleaning tools, such as those used for car windshields, may also be effective in this process.



Figure 5: Manual Cleaning

- 2. Utilizing Vacuum Suction for Cleaning:** Hoover suction cleaners use an air pump to collect dust and particles from various surfaces like floors and windows. These cleaners are powered by an electric motor to create suction force. Interestingly, the wattage of the vacuum cleaner doesn't necessarily determine its effectiveness. Instead, the efficiency is measured in air watts, which represent how effectively the input power is converted into airflow. When using a hoover cleaner, it's important to note that it may not be able to clean corners completely, and you may need to manually address these areas, as shown in Figure 6. This requires the operator to move around physically during the cleaning process, making proper training essential. Over time, scratches and accumulated dust can reduce the cleaner's ability to absorb sunlight effectively, impacting its performance in solar energy absorption.



Figure 6: Vacuum Suction Cleaning

- 3. Cleaning with Automatic Wipers:** In an automatic wiper-based cleaning system, a rubber wiper and a water pot are utilized to spray a mixture of water and cleaning agents. This process resembles the way car windows are cleaned, and it requires an automatic mechanism to operate and complete the task. The mechanism is powered by a battery, as illustrated in Figure 7. This method operates in a manner similar to the previous one and is triggered automatically by the suitable control system.



Figure 7: Automatic Wiper Based Cleaning

- 4. Cleaning using Electrostatic Repulsion:** The innovative device eliminates dust from solar panels without requiring water or brushes by utilizing electrostatic repulsion. Here's how it works: An electrode positioned slightly above the solar panel imparts an electrical charge to the dust particles, initiating the device's operation. Subsequently, the dust particles are pushed away from the solar panel's surface due to the opposite charge applied to a thin, transparent conductive layer on the panel's glass surface. To automate this process, a basic electric motor and guide rails can be employed along the panel's perimeter. All that's needed is a straightforward metal bar to pass over the panel and generate an electric field that charges the dust particles as it moves. Researchers determined the appropriate voltage range to counteract gravitational and adhesive forces and effectively remove the dust.

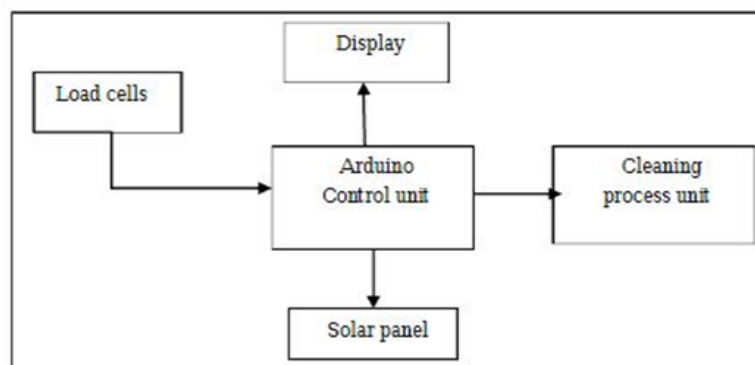

Figure 8: Electrostatic Repulsion

- 5. Drones with Mapping Cameras and Sensors:** Solar panels need to be cleaned, but doing so is challenging because they continuously gather dust, grime, and other debris and are frequently found on top of large buildings or in isolated locations. A drone-based setup is created as a result. It will include a quad copter that is contained in a weather proof docking station that is placed close to the disputed solar panels. Two doors on top of the station will slide open at regular intervals, and the drone will emerge from them on a motorised platform before the plane lifts off and flies up to the panel's figure9. The

drone will then line itself above each panel, spray it with cleaning fluid, then move on to the next one using tools such as Lid AR sensors and mapping cameras. The aeroplane will return to the docking station after the cleaning work is finished and be lowered into it [7]. A robotic system will then swap out its batteries if necessary and swap out its empty cleaning fluid tank with one that is full.



Figure 9: Drones with Mapping Cameras and Sensors

- 6. Internet of Things (IOT) Based: ARDUINO-** Internet based system to continuously Monitor the solar panel parameters to detect any faults in connections & circuit failures. It will then inform for it to timely get repaired. It transmits the power output to IOT system. To maximize the efficiency of solar power plants and ensure optimal power generation, continuous monitoring and maintenance are essential. This involves the proactive identification of issues such as damaged solar panels, loose electrical connections, and the accumulation of dust on panels, all of which can negatively impact solar energy output. The proposed solution for automated solar power monitoring leverages the Internet of Things (IoT) technology, allowing for remote and automatic monitoring of solar power systems via the internet. In this system, we employ an Arduino-based setup to monitor the performance of a 10-watt solar panel. This monitoring system operates continuously, providing real-time data on the solar panel's power output. This data is then transmitted to an IoT platform via the internet for analysis and further action, as illustrated in Figure 6.

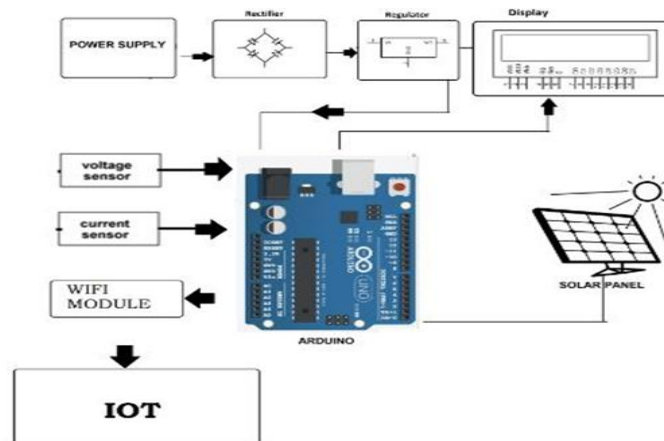

Figure 10: Arduino based System

7. **Robotics:** Thanks to advancements in robotics technology, companies such as Italy's Wash Panel have developed specialized automatic and semi-automatic robots designed for cleaning solar panels. These robots cater to a variety of settings, including carports, greenhouses, and shed roofs, by offering portable semi-automatic models. For larger installations in dusty environments requiring frequent cleaning, they also offer fixed roof robots.

8. **Nanoparticle coatings:** Researchers at India's Department of Science and Technology's International Advanced Research Centre for Powder Metallurgy and New Materials (ARCI) have developed an innovative solar panel coating designed to combat dirt and pollution-related efficiency loss. India's challenging environmental conditions, characterized by high temperatures, humidity, and severe pollution, can hinder the performance of photovoltaic (PV) panels. This novel technology relies on nanoparticles and is exceptionally transparent while effectively repelling dust. The coating allows for easy removal of dirt with water, all without compromising the panel's effectiveness. Marichin Technologies, an Indian company, is responsible for commercializing this breakthrough solution.

Table1: An Analysis of Various Solar Panel Cleaning Systems

Technology	Procedure for Cleaning	Cleaning Efficiency	Special Qualities	Drawbacks	Remarks	Ref
Cleaning Manually	Hand Washing	Eliminates various forms of dust, including oily residue and avian excrement.	Cleaning Assisted by Humans	(i) Manpower Is Needed (ii) Large Solar Farms Are Ineffective (iii) The solar panel's surface may be harmed.	Small Solar Home Systems	[10]
	Kit for Cleaning	Eliminates various forms of dust, including oily residues and bird excrement.	Additional shafts and a unique cleaner		Implementable Useful for large-scale rooftop solar plants with arbitrary array configurations	
	Misting Water	removes particles of dust	Water hose applied manually		Better suited for locations with lots of water	
	Rainwater	removes	Using		PV Site	

	Purification	particles of dust	Natural Cleaning		situated in Tropical regions	
Self-Cleaning Approach	translucent Nano film with a coating	cleaner than a natural method using rainwater	A thin film covering has no impact on a panel's effectiveness .	Low system reliability across a range of site conditions	Useful for installing remote sensor networks powered by PV	[11], [12]
Water Cleaning Robots	automatic sprinkler system	removes dust particles and bird droppings	Regular water rinses prevent accumulated filth from adhering.	Not appropriate in areas with a lack of water	Useful for rooftop solar power systems	[13]
Robotic System	Water Based Cleaning	Clean hard dirt and dust deposits	After cleaning, the smoothness of the panel surface is still present.	Sophisticated and complicated system, additional costing of water	Beneficial for expansive solar installations situated in areas abundant in water resources.	[14-17]
	Without Water Cleaning	Without using any water, remove both clean and difficult dirt	low cost of operating	limited to a specific module Configuration	Beneficial for expansive solar facilities operating under water scarcity conditions.	[18,9]
	Robotics with IoT Integration	Cleaning efficacy varies depending on the methodology utilised, which might include both water-based and waterless methods.	(i) Remotely tracking current plant conditions (ii) Needs no human involvement	Complex system, high initial investment, and requirement for a skilled and qualified supervisor	Suitable for remote big solar plants and semi-arid regions	[20, 19]

III. SOLAR PANEL CLEANING USING ARTIFICIAL INTELLIGENCE

Cleaning solar panels is a critical task to ensure their efficiency and maximize energy production [21]. Traditionally, manual cleaning or automated cleaning systems like water sprinklers or brushes have been used. However, artificial intelligence (AI) can revolutionize the way solar panels are cleaned by making the process more efficient and cost-effective.

Here's how AI can be utilized for solar panel cleaning:

- **Automated Drones:** Drones equipped with AI-powered image recognition can fly over solar panel arrays, identify dirty or shaded areas, and schedule cleaning based on real-time data. AI algorithms can also optimize the cleaning route to minimize energy loss during the cleaning process.
- **Computer Vision:** AI can be used to analyse images captured by cameras mounted on the ground or on drones. By recognizing dirty or faulty solar panels, the AI system can automatically trigger cleaning operations.
- **Weather Prediction and Scheduling:** AI algorithms can analyze weather forecasts and plan cleaning schedules during periods of low solar power generation or predict when panels are likely to get dirty, optimizing cleaning efforts.
- **Robotics and Automation:** AI-powered robotic systems can be designed to move autonomously on the solar panels' surface, using soft brushes or other cleaning mechanisms to remove dust and debris.
- **Machine Learning and Predictive Maintenance:** By applying machine learning to historical data, AI can predict when solar panels are likely to get dirty based on location, weather conditions, and other factors. This allows for proactive cleaning before performance degradation occurs.
- **Autonomous Cleaning Vehicles:** AI can be integrated into specialized vehicles that move along the rows of solar panels and use various cleaning techniques to keep them clean.
- **Drone Swarms:** Multiple drones equipped with AI can work collaboratively to cover large solar farms efficiently, identifying and cleaning panels as a team.
- **Energy Yield Optimization:** AI algorithms can analyze the impact of dirt and other environmental factors on energy generation. By continually monitoring and cleaning panels, AI can maximize the solar farm's overall output.

Benefits of using AI for solar panel cleaning

- **Increased Efficiency:** AI can optimize cleaning schedules and methods, reducing energy losses due to dirty panels.

- **Cost Savings:** Automated cleaning with AI can lower labor costs and improve the longevity of solar panels, leading to overall cost savings.
- **Real-Time Monitoring:** AI can continuously monitor the performance of solar panels and alert operators in case of faults or inefficiencies.
- **Environmental Impact:** By maximizing energy production, AI-powered cleaning contributes to reducing reliance on fossil fuels, thus having a positive impact on the environment.
- **Scalability:** AI can easily scale to handle large solar panel installations, making it ideal for utility-scale solar farms.

IV. SUGGESTED SCHEMATIC DIAGRAMS FOR IMPLEMENTING MACHINE LEARNING IN A PHOTOVOLTAIC (PV) CLEANING SYSTEM

Machine learning is well-equipped to tackle this particular problem because it can effectively adopt specific patterns and trends from the data it's trained on. It can then use this knowledge to make accurate predictions or classifications based on the similar patterns it has learned.

1. **Data Selection:** There are several factors that can impact the efficiency of a solar photovoltaic module. These factors include the density of dust, the temperature of the module (T_{pv}), the ambient temperature and humidity. Air mass and solar irradiance (G_{pv}), which measures the amount of solar energy received, are considered input parameters. On the other hand, the output parameters are array voltage (V_{pv}) and array current (I_{pv}). Including more of these parameters in a model can increase its accuracy, but it also makes the system more complex and costly. In the context of Middle Eastern countries, where varying levels of dust accumulation occur throughout the year, it has been observed that seasonal meteorological data play a crucial role in determining when and how cleaning interventions should be conducted.
2. **Data Processing:** Before creating a calibration model for decision-making, it's important to address any inaccuracies in the gathered data. There are various methods to process data, and the choice depends on your specific needs. One straightforward method is time series analysis, where each input parameter is treated individually, without considering relationships between them. On the other hand, simple feature engineering involves summarizing input data statistically by calculating measures like mean, mode, median, and variance. This approach groups data instances that share common features into one.

For more complex situations with a large number of parameters and a need for high accuracy, Principal Component Analysis (PCA) is a valuable tool. PCA helps identify the most significant patterns and relationships within the data. Furthermore, there are advanced data processing techniques beyond these options that can be effectively utilized for your specific data calibration needs.

3. **Model Selection:** Calibration modelling involves establishing a connection between various parameters, and one of the simplest approaches to achieve this is through logistic regression. However, there are more advanced machine learning techniques available, such as support vector machines, artificial neural networks, random forests, transfer

learning, and deep learning, which can be considered. The choice among these methods should be based on factors like the data quality, the specific parameters under consideration, and the level of accuracy required.

- 4. Evaluation of Performance:** After carefully assessing different combinations of machine learning models and data processing tools, we ultimately select the optimal combination based on several key factors, namely system accuracy, cost-effectiveness, energy efficiency, and computational speed. This selection process aligns closely with the specific requirements outlined for the solar photovoltaic system.

V. CONCLUSION

Solar panels have proven to be a highly viable and sustainable solution for generating clean and renewable energy. Solar panels harness energy from the sun, a virtually limitless and clean source of power. By converting sunlight into electricity, solar panels help reduce greenhouse gas emissions, air pollution and reliance on fossil fuels, reducing the effects of climate change in the process [24]. The automation of cleaning operations reduces the dependence on human intervention, minimizing the likelihood of errors and ensuring a reliable and consistent performance of the solar panels over time. The integration of IoT technology provides real-time monitoring capabilities, enabling the system to assess the cleanliness status of panels and determine the most appropriate cleaning schedules. Through data-driven analytics and sensor feedback, the cleaning process becomes highly adaptable to prevailing weather conditions. For instance, the system can intelligently avoid cleaning during rainy periods but prioritize cleaning after dusty days, maximizing the effectiveness of each cleaning cycle [25]. This increased reliability translates to greater confidence in the solar energy system's overall performance and a reduced need for manual maintenance, ultimately contributing to lower operational costs. As the world increasingly relies on renewable energy, particularly solar power, the implementation of IoT-driven automated cleaning systems becomes a pivotal move in enhancing the sustainability and effectiveness of energy generation. Through the fusion of optimization methods and the connectivity of the Internet of Things (IoT), the process of cleaning solar panels can be made more efficient, environmentally conscious, and dependable. This advancement reinforces solar energy's vital role in the global shift toward a cleaner and more sustainable future.

REFERENCES

- [1] S. A. Suleiman, H. H. Hussein, N. S. H. Nik Leh, and M. S. I. Razali, "Effects of Dust on the Performance of PV Panels," *Int. J. Mech. Aerospace, Ind. Mechatron. Manuf. Eng.*, vol. 5, no. 10, pp. 2028–2033, 2011.
- [2] D. Singh Rajput and K. Sudhakar, "Effect Of Dust On The Performance Of Solar PV Panel," *Int. J. ChemTech Res.*, vol. 5, no. 2, pp. 1083–1086, 2013.
- [3] Priyadharsini K. a, Dinesh Kumar J.R, Elegant method to improve the efficiency of remotely located solar panels using IoT, 2021.
- [4] T.K. Rana, Naomi Mallik, Bidipta Dutta "IOT Based string failure detection and monitoring system" on 2020 4th international conference on Electronics „Materials Engineering & Nano-Technology (IEMENTech).
- [5] G. Librandi, J. Narain, and H. Yu, "Autonomous Photovoltaic Panels Cleaning System," Brooklyn, NY, 2012.
- [6] <https://news.mit.edu/2022/solar-panels-dust-magnets-0311>.
- [7] <https://newatlas.com/drones/drone-solar-panel-cleaning/>.

- [8] <https://nevonprojects.com/iot-solar-power-monitoring-system/>.
- [9] https://www.researchgate.net/publication/271425355_Improvement_in_solar_panel_efficiency_using_solar_concentration_by_simple_mirrors_and_by_cooling.
- [10] M. K. Smith, C. C. Wamser, K. E. James, S. Moody, D. J. Sailor, and T. N. Rosenstiel, "Effects of natural and manual cleaning on photovoltaic output," *J. Sol. Energy Eng.*, vol. 135, no. 3, Aug. 2013.
- [11] J. Son, S. Kundu, L. K. Verma, M. Sakhuja, A. J. Danner, C. S. Bhatia and H. Yang, "A practical super-hydrophilic self cleaning and antireflective surface for outdoor photovoltaic applications," *Sol. Energy Mater. Sol. Cells*, vol. 98, pp. 46–51, Mar. 2012.
- [12] G. He, C. Zhou, and Z. Li, "Review of self-cleaning method for solar cell array," *Procedia Eng.*, vol. 16, pp. 640–645, 2011.
- [13] Heliotex. (Apr. 17, 2020). Automatic Solar Panel Celaning System [Online]. Available: <https://www.solarpanelcleaningsystems.com/>
- [14] Gekko Solar Robot. [Online]. Available: <https://serbot.ch/en/solar-panelscleaning/gekko-solar-robot>
- [15] Gekko Solar Farm Robot. [Online]. Available: <https://www.serbot.ch/en/solar-panels-cleaning/gekko-solar-farm-robot>
- [16] Greenbotic's Robotic Cleaning System. [Online]. Available: <https://www.greentechmedia.com/articles/read/sunpower-cleans-upsolar-with-acquisiton-of-greenbotics#gs.YzTxhJI>
- [17] M. Hardt, "HECTOR-heliostat cleaning team-oriented robot," in *Proc. Solar-PACES*, Granada, Spain, Sep. 2011, pp. 20–23.
- [18] Solar Brush. [Online]. Available: <https://www.aerialpower.com/solarbrush/>
- [19] (Apr. 15, 2020). Intellegent Cleaning Robots. Available: [Online]. Available: <https://bosonrobotics.com/en/products/robot>
- [20] N. Khadka, A. Bista, B. Adhikari, A. Shrestha, and D. Bista, "Smart solar photovoltaic panel cleaning system," *IOP Conf. Ser., Earth Environ. Sci.*, vol. 463, Apr. 2020, Art. no. 012121
- [21] S. M. Al-Dhaheri, L. A. Lamont, L. El-Chaar, and O. A. Al-Ameri, "Automated design for boosting offshore photovoltaic (PV) performance," in *Proc. IEEE PES*, 2010, pp. 1–6.
- [22] R. K. Jones, A. Baras, A. A. Saeeri, A. Al Qahtani, A. O. Al Amoudi, Y. Al Shaya, M. Alodan, and S. A. Al-Hsaien, "Optimized cleaning cost and schedule based on observed soiling conditions for photovoltaic plants in central saudi arabia," *IEEE J. Photovolt.*, vol. 6, no. 3, pp. 730–738, May 2016.
- [23] M. Muller, L. Micheli, and A. A. Martinez-Morales, "A method to extract soiling loss data from soiling stations with imperfect cleaning schedules," in *Proc. IEEE 44th Photovoltaic Specialist Conf. (PVSC)*, Jun. 2017, pp. 2881–2886.
- [24] Akriti Garg, Atul Sarojwal, Desh Deepak Sharma, "Iot Based Modern Techniques for Performance Enhancement Of Solar Photovoltaics" *International Conference on Sustainable Development in Engineering, Management & Medical Sciences-2023 (SDEMMS-2023)*
- [25] Ahmed Med YAHYA, Performance analysis of a 48kWp grid-connected photovoltaic plant in the Sahelian climate conditions of Nouakchott, Mauritania, 2021.