

# PERFORMANCE ANALYSIS OF A HYBRID SOLAR-WIND POWER GENERATION SYSTEM

## Abstract

To fulfill the demands of rising energy consumption, reduce environmental pollution, and generate socioeconomic advantages for sustainable development, renewable energy resources are now being implemented on a huge scale. Integration of renewable energy sources gives the country the ability to fulfill its emission objectives while also ensuring energy security, making significant cost savings, and reducing greenhouse gas emissions. Because of the intermittent nature of renewable energy's single source, continuous production is impossible without a hybrid renewable energy system. In order to produce electrical energy, this study focuses on the usage of wind turbines and solar photovoltaic generation. Utilizing the MPPT technique, the hybrid power system's performance is evaluated based on the output nature in order to maximize output power.

**Keywords:** Hybrid system, Maximum power point tracking, controller, De-risk, markets.

## Authors

### Jeyanthi M

Department of Electrical and Electronics Engineering,  
Velammal College of Engineering  
Technology, Madurai, Tamil Nadu, India.  
jeyanthi19@gmail.com

### R Narmatha Banu

Department of Electrical and Electronics Engineering,  
Velammal College of Engineering  
Technology, Madurai, Tamil Nadu, India.  
r.n.banu@vcet.ac.in

## I. INTRODUCTION

The utilization of renewable energy for the electricity generation has recently risen to the top of the research priority list. The attractiveness of renewable energy comes from its continual, simple availability and pollution-free nature. The far more potential form of renewable energy on the market is photovoltaic cell energy generation due to its cheap cost, ease of implementation, and portability. It collaborates with other renewable energy sources including auxiliary units (AU) and wind fuel cells to produce hybrid renewable energy sources. This is typically combined with a battery storage system, leading to the implementation of a hybrid renewable energy system, where more than two renewable energy sources were implemented, in order to have continuous power supply and efficiency improvement. When all the RES fail to provide electricity, an auxiliary unit was utilized as a backup generator. It may be a super capacitor or a diesel generator set [1]. India's annual solar energy is equivalent to more than 5000 trillion. This study examined the influence of the following variables on the final decision: batteries and wind turbines, the number of PV panels, the capacity of transferred power by the inverter, the height of the wind turbine tower, as well as angle of PV panels. This energy's low energy density and intermittent availability make it highly reliant for a variety of uses. Wind power is widely available, renewable, and clean. It can lower the emissions of greenhouse gases when used to replace fossil fuels. Utilizing wind energy at low to medium levels of permeability won't provide a problem during intermittent winds. A large-scale motor generator of a pumped storage power station's many fault types along with treatments served as useful examples for comparable fault prevention and diagnostics [2]. The improved crow search algorithm (ICSA) was implemented for designing a different combination of the stand-alone hybrid system such as Solar PV, wind power, and batteries to improve supply reliability over the horizon while reducing the NPC("Net Present Cost"). The batteries and wind turbines, number of PV panels, the angle of PV panels, the capacity of transferred power by inverter, and wind tower height were taken as the decision variables. [3]. The PV system may be used to generate reliable energy for consumption in conjunction with other renewable or non-renewable sources like wind and diesel respectively. Along with its many benefits, solar energy protection has certain disadvantages, including as the expense of system-wide maintenance, the effect of maintenance on the environment, and the rise in consumer awareness. We must be mindful of the fact that solving these issues paves the way for the globe to achieve the essential environmental protection [4]. The technical obstacles that must be overcome in order for inverter-based generation to dominate or be the sole source of power for power grids include voltage & frequency management, power system security assessment, power system stability resource predicting approaches for unit commitment, integration of behind-the-meter generators and loads into the grid, power system flexibility assessment, frequency and voltage support, and techniques for improving protection schemes [5]. The in-rush current for 3-phase mode of a hybrid solar wind production system integrated with a grid was examined using 2 distinct kinds of DPFC(Distributed Power Flow Controller) models, and it was shown that DPFC was more efficient (I.e., 20A) than DPFC with batteries (I.e., 15A) [6]. A reliable and continuous power supply for various load conditions was ensured from the hybrid power generation unit with MPPT controllers [7]. [8] Investigated were the collaborative actions of the hybrid system with an energy management technique on the basis of FLC("Fuzzy Logic Controller") under variations in renewable-based power protection. The development of an useful and consistent technique for the techno-economic sizing of such hybrid systems with experimentally validated models of the hybrid system's component parts that may be helpful for determining the feasibility of the stand-alone hybrid renewable

system. Analyzing several energy management strategies on the hybrid structure and comparing them with fuzzy logic controllers. In Article [9] 7 MPPT techniques have been used by considering the algorithm complexity, parameter's steady state settling time, PV array dependency, MPP tracking speed, efficiency, and handling of partial shading. The hybrid MPPT technique is extracting the maximum PV power with a less steady state. The hybrid (P&O-PSO) MPPT approach proved very accurate and highly efficient in extracting the most PV power with the least amount of steady state oscillations. The technical and optimization problems related to the operation, development, and scalability of hybrid power systems should get additional funding [10]. With high penetration of distributor-generating resources, the grid-connected photovoltaic system [GCPVS] caused accidental stress on the electrical grid. MPPT, inverters that supported services such as frequency regulation, energy storage, and reactive power management are units crucial for easing the problems due to the growing adoption of GCPVS [12]. In the article [11], topology for hybrid energy used multi-input KY boost converters to collect the most power possible. Homer ("Hybrid Optimization Model For Electric Renewable") programme used local real-time field data on solar radiation and wind speed to simulate as well as optimise the operation of the hybrid system. When compared to traditional power plants, the CO<sub>2</sub> and net present cost (NPC) emissions might be lowered by roughly 29.65 percent and 16 tonnes annually, respectively [12]. According to experimental findings from the test bench operation made up of a PV wind hybrid system, the major energy provider is a PV array (84 percent), and the secondary energy provider is a wind turbine (16 percent) [13]. By combining the contributions from all the sources. The aim of this article is to present the energy production data from the hybrid power system used for lighting purposes.

## II. SOLAR PHOTOVOLTAIC-WIND HYBRID SYSTEM

The solar photovoltaic hybrid system, which uses wind as a supplemental power source, is a significant kind of solar hybrid system. This solar and wind energy combination is very wonderful. Another benefit of combining wind and solar systems is that, often, solar energy peaks happen when the wind isn't too strong and wind peak operating hours happen when solar energy is either nonexistent or at least at its peak. As a result, the systems' capacity for generating electricity fluctuates naturally. Because neither wind nor solar energy is as abundant as is required, wind and solar power systems are not as effective when used separately as they are when combined. For generating consistency, solar wind hybrid systems may be a superior option. Additionally, they may be combined with an additional power source, such as a good to fold a guarantee that we are consistent with the generation that utilizes batteries for everything. [3] In all circumstances involving wind turbines and solar cell (PV) systems, maximum voltage control is often utilized to maximize power production. Power conversion systems often use MPPT units, which transmit many loads for automated conversion, filtering, and control.

- 1. Benefits of Hybrid System:** De-risk the overall generation profile of a renewable plant and this has a further effect of maximizing the utility of the interconnection. It Provides more consistent and dependable power production, supplies continuous loads, and unlocks new markets for renewable. Longer battery life- Charging via simultaneous sharing of power between solar and wind, sources keep the battery in peak charge condition, leading to a longer life.

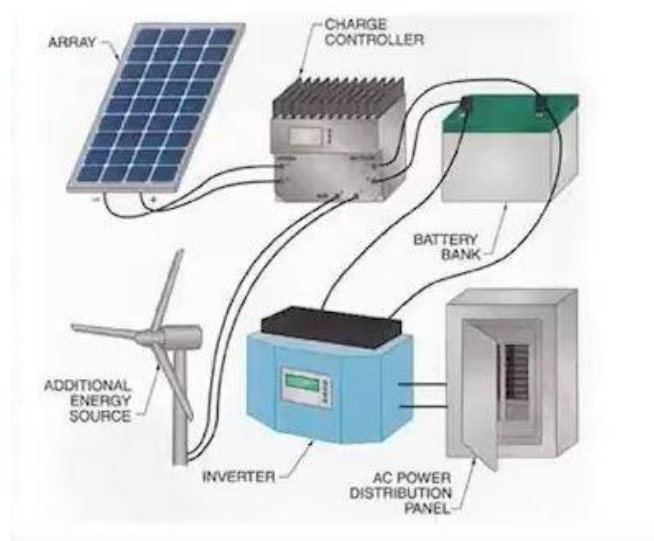

**Figure 1:** Model of Hybrid Power System

## 2. Block Diagram

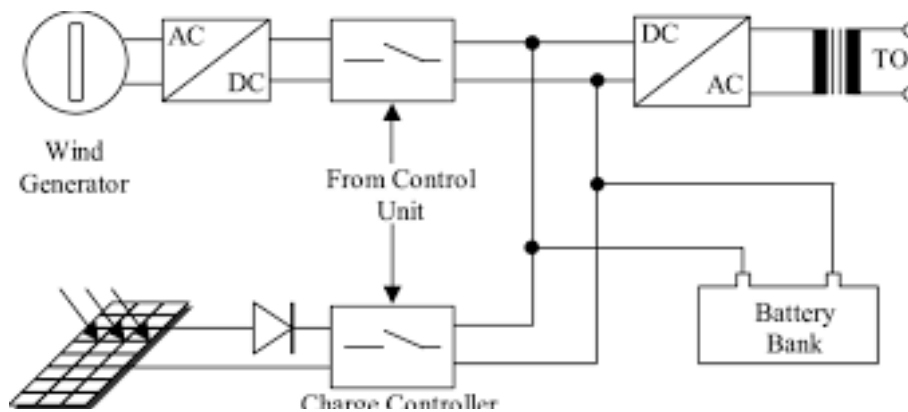

**Figure 2:** Block Diagram of Hybrid System.

## 3. Diagram Description

- Solar Panels:** The solar panel converts solar radiation into electrical energy. The PN junctions of these devices have similar properties to those of diodes, and they are constructed from semiconductors. When a photon is absorbed, the material's electron-proton system receives the energy from the photon, producing charge carriers at the junction. Charge carriers develop a potential gradient, accelerate in an electric field, and then circulate as currents across an external circuit at the junction area. A solar panel or array is made up of many modules linked electrically in a series-parallel configuration to provide the necessary current and voltage. Solar energy may be transformed into electrical energy via the use of solar panels, which can then be used to create electricity.
- Wind Turbine:** It is a device that uses the wind's motion to generate electricity by rotating its blades. There are 2 types of wind turbine: vertical as well as horizontal.

We use a horizontal-axis wind turbine in this setup. We need to store this power in a battery and then deliver it to the load since wind power is intermittent and does not supply continuous power. This is in order to get constant power.

- **Charge Controller:** As part of its function, the charge controller controls the active or inactive source, at the same time charges the battery, along with supplying power to the load. It is protected against overload, short circuits, and pole confusion, and has an automatic dump load function. It should also vary the power according to load demand. In order to meet load demand, both powers must be added. It should also take energy from a battery and supply it to the load when electricity is not being produced.
- **Battery Bank:** The size of the battery bank may be selected based on the required load [14] A charge controller MPPT (maximum PowerPoint tracking), which controls the battery's charge, is connected to the PV panel and wind turbine. The battery drives to the inverter, inverter goes to the AC distribution panel. The charge controller should control the battery's charging in a certain way while receiving variable input. the controller needs to look at 2 inputs to optimize battery charging.

**Table 1: Hybrid System Specifications**

| <b>Solar PV Module Used (250/260/265/270/275)/24VSOLAR PV MODULE At STC 1000W/m<sup>2</sup>, Temp=25°C</b> |                       |
|--|-----------------------|
| <b>Component Description</b>   | <b>Specifications</b> |
| Model  | HST60F265P            |
| Short circuit current I <sub>sc</sub>  | 9.5A                  |
| Open circuit voltage V <sub>oc</sub>   | 38.5V                 |
| V <sub>pm</sub>  | 30.88V                |
| I <sub>pm</sub>  | 9.01A                 |
| P <sub>max</sub>   | 278.49W               |
| Temperature(°C)  | 25.0                  |
| Dimension  | 1650*987*40 mm        |
| Irradiation (W/ m <sup>2</sup> )   | 1000                  |
| <b>Wind Parameters</b>   |                       |
| Rotor swept area   | 1.207-meter square    |
| Rotor diameter   | 1.24 meter            |
| Number of blades   | 3                     |
| Nominal power  | 177 watts             |
| Output voltage   | 10- 35VAC             |
| Axis type  | HAWT                  |
| Highest design wind speed  | 25 meters per second  |
| Wind direction adjustment mechanism  | Tail                  |
| Maximum power (20m/s)  | 524W                  |

### III. TENTATIVE OUTCOMES AND DISCUSSION

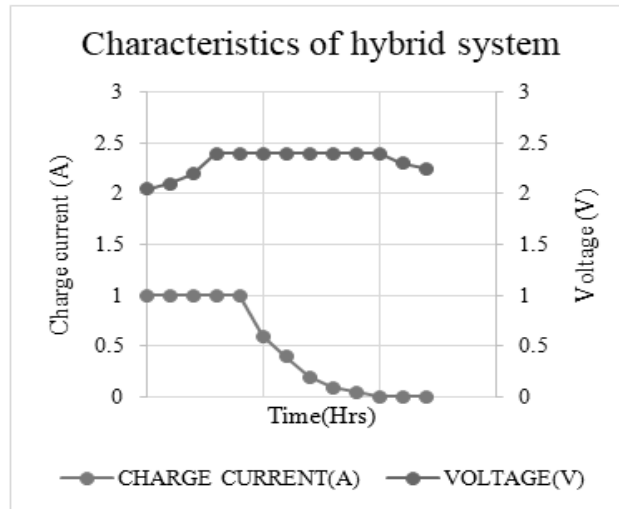

**Figure 3:** Characteristics of Hybrid System.

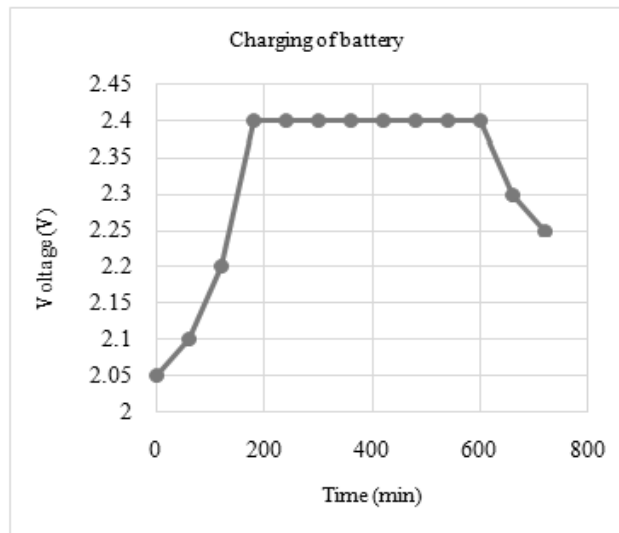

**Figure 4:** Battery Charging Concerning Time

This work examines how well a constructed hybrid solar wind power generation system performs. Figure 3 shows that the voltage rises at constant current to peak voltage when full charge is reached current level was off and at last, voltage is lowered to float charge level. Figure 4 shows that the battery terminal voltage increases with time, because of the continuous energy sources battery voltage increases over time.

### IV. CONCLUSION

The hybrid power generation unit based on the wind solar system was developed to overcome intermittency and uncertainty and make the power system more reliable, rechargeable and remarkable. The performance evaluation of the hybrid (solar-wind) power system under different load circumstances is presented in the paper. The hybrid system's

output power increases compared to the individual subsystems. Also found that the MPPT charger switching the battery charging from the maximum power from either source automatically was studied.

## REFERENCES

- [1] Pranita Rathod, Sanjoy Kumar Mishra, Sujit Kumar Bhuyan, Renewable energy generation system connected to microgrid and analysis of energy management: a critical review (IJPEDS), Vol.13, No.1, March 2022:470-479.
- [2] Aishwarya Pandey, Banu Pratap Singh, A review of Motor -Generator Pair System for Renewable Energy Systems, International Journal of Scientific Research and Engineering Trends Volume 8, Issue 1, Jan - Feb 2022, ISSN(Online): 2395-566X.
- [3] Sasan Moghaddam, Mehdi Bigdeli, Majid Moradlou, Pierluigi Siano, Designing of a standalone hybrid PV /wind /battery system using improved crow search algorithm considering reliability index, International Journal of Energy and Environmental Engineering (2019 )10:429- 449.
- [4] Andjela B Stanojevic, Application of photovoltaic technology in the use of solar energy, Ann Environ Sci Toxicoi 5(1):094-098.
- [5] Njabulo Mollo, Jason Brown, Tony Ahfock, Impact of intermittent renewable energy generation penetration on the power system networks – A review, Technology and Economics of Smart Grids and Sustainable Energy (2021)6:25. pg. 1-19.
- [6] Abilash Sen, Atanu Banerjee, Haricharan Nannam, A comparative analysis between two DPFC models in a grid connected Hybrid Solar-Wind Generation system, PESGRE45664.2020.9070373.
- [7] Intakhab Alam Laghari, M. Ali Tunio, Rameez Shaikh, Noman Khan, Development and Performance Analysis of Small Scale Prototype Model for Hybrid Power Generation (SSRG-IJEEE)-volume 7 issue 2-February 2020. pg.18-22.
- [8] O.Erdinc, O, Elma,M. Uzunoglu, U.S.Selamogullari, B.Vural, E.Ugur,A.R.Boynuegri, Experimental performance assessment of an online energy management strategy for varying renewable power production suppression, International Journal of Hydrogen Energy 37(2012)4737-4748.
- [9] C H Hussaian Basha, C. Rani, Performance Analysis of MPPT Techniques for Dynamic Irradiation Condition of Solar PV International Journal of fuzzy system 31<sup>st</sup> October 2020.
- [10] Kunle Babaremu,Nmesoma Olumba,Ikenna Chris-Okoro, Konyegwachie Chucwuma, Tien-Chien Jen, Oluseyi Oladijo and Esther Akinlabi, Overview of Solar -Wind Hybrid Products:Prominent Challenges and Possible Solutions, Energies 2022,15,6014.
- [11] Srishti Dehariya, Anil Kumar Kori, A Review Article of Control and Performance Evaluation of Fopid based Single-Stage Grid connected PV system,International Journal of Scientific Research and Engineering Trends; volume 8,issue 1, Jan-Feb 2022 ISSN (online):2395 -566X.
- [12] M.Pushpavalli, N.M Jothi Swaroopan, Performance analysis of hybrid photovoltaic/ wind energy system using K Y booster converter, International Journal of Power Electronics and Drive System, Vol.10, No.1, March 2019, pp 433 - 443.
- [13] R.Maouedj, A.Mammeri, M.D. Draou and B.Benyoucef, Performance evaluation of hybrid Photovoltaic-Wind power system, Energy Procedia 50 (2014) 797-807.
- [14] S.Gopalakrishnan,R. Sasikumar,Hybrid Power Generation Using-Vertical Axis Wind Turbine and Solar Panel, International Journal of Research in Engineering and Science (IJRES)ISSN (Online): 2320-9364, ISSN (Print): 2320-9356 www.ijres.org Volume 10 Issue 2 | 2022 | PP. 37-45