

# SMART SWITCHBOARD

## Abstract

In light of anthropogenic influence and its adverse effects on the global environment, there is a discernible transition towards a more ecologically sound and enduring energy framework across the globe. Within both individual and communal structures, there exists a compelling aspiration to curtail electricity consumption, mechanize appliances, and optimize the utilization of electric power within edifices. This undertaking introduces a comprehensive exposition and realization of a fortified intelligent residential switching system founded on wireless intercommunications and autonomous energy acquisition. The proposed fortified intelligent residential switching system seamlessly amalgamates building electricity access control, self-energy procurement and retention mechanisms for dynamic electronic components and circuitry, as well as wireless communication functionalities for intelligent switches and electrical outlets.

**Keywords:** Smart home; energy harvesting; sustainable energy system; wireless communication; home automation system

## Authors

### Alpa K. Oza

Assistant Professor  
Department of Information Technology  
SAL College of Engineering  
SAL Education  
Ahmedabad, Gujarat, India.  
oalpa12@gmail.com

### Maitri Patel

Associate Professor  
Department of Computer Sciences and Engineering  
Institute of Advanced Research  
Gujarat, India.  
maitru1487288@gmail.com

### Parita V Shah

Assistant Professor  
Department of Computer Engineering  
Vidush Somany Institute of Technology and Research  
Kadi Sarva Vishwavidyalaya  
Sarva Vidyalaya Kelavani Mandal  
Kadi, India.  
paritaponkiya@gmail.com

### Krupali Dave

Assistant Professor  
Department of Computer Engineering  
Vidush Somany Institute of Technology and Research  
Kadi Sarva Vishwavidyalaya  
Sarva Vidyalaya Kelavani Mandal  
Kadi, India.  
krupalidave1994@gmail.com

### Shwetal Sathavara

Assistant Professor  
Department of Computer Science Engineering  
Vidush Somany Institute of Technology and Research, Kadi Sarva Vishwavidyalaya  
Sarva Vidyalaya Kelavani Mandal  
Kadi, India.  
s4shwetal@gmail.com

## I. INTRODUCTION

In an era dominated by discussions about intelligent systems, a group of individuals conceived an idea to enhance living standards while embracing modern technology. They recognized the value of imbuing homes with human-like qualities. For instance, the inconvenience of forgetting to turn off lights, resulting in unnecessary expenses, prompted them to conceptualize a Home Automation System. This system encompasses the comprehensive control of household features like lighting, TV, AC, garage, and doors, aiming for a seamless integration of technology [1].

The concept of a Smart Switchboard emerged as a solution, allowing people to remotely manage their electronic devices from anywhere globally through mobile applications and internet connectivity. This entails connecting a module to a regular switchboard, facilitated by an Arduino chip that links the module to the internet [2]. This module establishes an internet connection and subsequently interfaces with the cloud, enabling the control of connected devices. These modules incorporate microcontrollers that facilitate the manipulation of electronic devices through applications, including setting schedules for activation and deactivation.

The primary objective of this proposal is to furnish users with distant access, convenience, heightened safety, and energy efficiency [3]. Remote access empowers users to govern their homes through devices like laptops, tablets, and smartphones. Leveraging home automation fosters a more comfortable and habitable living space. Whether it's programming the thermostat for preferred temperature settings, using smart speakers for post-work relaxation, or adjusting lighting based on the time of day, these functionalities offer convenience [4]. Automation can also be applied to initiate devices at specific times or regulate them remotely, streamlining daily routines. By automating tasks like locking doors and managing lights, individuals can allocate their focus elsewhere.

Incorporating intelligent fire detectors, carbon monoxide monitors, pressure sensors, and other security features adds an additional layer of protection to residences. Furthermore, home automation promotes prudent energy consumption. For instance, optimizing lighting duration or reducing temperatures in unoccupied rooms can yield energy savings [4].

Looking ahead, homes could integrate sensors like motion, light, and temperature sensors to trigger device actions based on prevailing conditions. Increased energy conservation could be achieved by activating devices only when the house is occupied and dimming unnecessary lights. Seamlessly merging this system with home security solutions offers enhanced control and safety. Scaling up, there's potential to extend this automation to larger settings like offices and factories [5]. Standardization becomes pivotal, enabling comprehensive smart homes that manage appliances, lighting, environment, energy, and security, while also allowing compatibility with other networks.

## II. LITERATURE REVIEW

**1. Utilizing Bluetooth Technology in Home Automation via Cell Phones:** The implementation of home automation systems using Bluetooth entails establishing a connection between household appliances and the Arduino BT board by means of relay-linked input and output ports. The programming of the Arduino BT board is grounded in

the interactive C language tailored for microcontrollers, with Bluetooth serving as the intermediary for connectivity [6]. A password protection mechanism is incorporated to ensure security, thereby confining access exclusively to authorized users. Wireless interaction between the Arduino BT board and mobile phones is initiated through Bluetooth pairing. This configuration employs a Python script adaptable to various Symbian OS environments, thus offering portability. To enable two-way communication, a specialized circuit is formulated and integrated to convey feedback from the mobile phone, thereby reflecting the operational status of the appliance [7].

- 2. Employing Zig Bee Technology for Cell Phone-Controlled Home Automation:** The organization and oversight of household appliances' functionality are accomplished by employing a Zigbee-based framework [8]. Device performance data is collected and stored by network coordinators. This procedure is enabled through a Wi-Fi network that employs a standard wireless ADSL modem router featuring four switch ports. The process of reconfiguration involves modifying the network's SSID and Wi-Fi security parameters. Security-related messages initially undergo processing via the virtual home algorithm. After being verified as secure, these messages are re-encrypted and then directed to the relevant network device within the domestic setting. Messages are disseminated to endpoints throughout the Zigbee network via the Zigbee controller. The virtual home algorithm is responsible for authenticating the security of all incoming messages. The adoption of Zigbee communication provides notable advantages in reducing system expenses and simplifying installation procedures, thus enhancing system affordability and facilitating minimally disruptive implementation [9].
- 3. Harnessing GSM Technology for Cell Phone-Controlled Home Automation:** The integration of cellular phones and GSM technology has elicited considerable interest in the exploration of GSM-based home automation. Within the domain of GSM communication, various approaches, including SMS-based, GPRS-based, and dual-tone multi-frequency (DTMF) based methods, have been thoroughly investigated. Within the envisioned system, the interaction between home sensors and devices is mediated through the home network, facilitated by both GSM technology and the Subscriber Identity Module (SIM). A transducer assumes a central role by converting mechanical actions into electrical signals, subsequently inputted into the microcontroller. Notably, the system's sensors translate physical properties like sound, temperature, and humidity into distinct parameters, specifically voltage levels. Through meticulous analysis, the microcontroller comprehends these signals and translates them into instructions that can be understood by the GSM module. The determination of the communication mode—whether it is SMS, GPRS, or DTMF—is contingent upon the specific command received by the GSM module [7].
- 4. Advanced Home Security:** While traditional security systems serve the primary purpose of safeguarding homeowners and their assets against potential intruders, a smart home security system extends its functionality to provide a multitude of additional advantages. Leveraging home automation technology, this system promptly alerts homeowners to any emerging issues, allowing for immediate investigation. Moreover, artificial intelligence algorithms continuously monitor the homeowner's routines and vital data, triggering alerts to emergency services as needed [10].

5. **Intelligent Fire Safety for Smart Homes:** In contrast to conventional fire alarms, a smart home security system provides a comprehensive level of protection. This advanced system not only detects indications of fire but also monitors carbon monoxide levels, offering a holistic safety approach. Its coverage extends to all corners of the residence. Should a fire outbreak occur, the smart home security system is designed to promptly notify the homeowner and alert emergency services. Moreover, through the integration of artificial intelligence, the system can precisely identify the fire's location and relay this crucial information to responding fire department personnel [11].
6. **Enhanced Access Control:** By integrating security codes, motion detectors, and cameras, a smart home security system gains insights essential for distinguishing among residents, authorized visitors, and potential intruders. Motion detectors initiate alerts, signaling the artificial intelligence program to assess the situation at hand. Through the incorporation of facial recognition algorithms and security codes, the security system effectively manages entry, granting access to residents while employing preconfigured criteria to limit entry for others [12].

In instances where the smart home security system identifies an unfamiliar individual, it can furnish homeowners with video footage of the visitor. Approved visitors can be granted remote access and entry clearance, while unwanted visitors can be disregarded. Additionally, unauthorized attempts to breach the premises trigger an automatic police notification [13].

7. **Cell Phone-Controlled Home Automation via Wi-Fi:** The fundamental components of the Wi-Fi enabled residential automation system consist of three primary modules: the server, the hardware interface module, and the software package. The system model's layout is delineated in the schematic representation. The interconnection between the server and the hardware interface module is facilitated by Wi-Fi technology, which is also employed to access the server's web-centric application. Functioning in tandem with an internet connection, the server enables remote user access through a compatible web browser to its web-based application interface. The contemporary residential automation software is bifurcated into server application software and Microcontroller (Arduino) firmware. Written in C language and accompanied by its integrated development environment (IDE), the Arduino software manages the acquisition of events from interconnected sensors, activates pre-programmed actuators, and communicates data to the server's database, concurrently upholding a historical record of activities. The envisioned residential automation system's server application software, contrived through the utilization of asp.net, manifests as a web-oriented application. This application is accessible within the internal network or externally via the internet, contingent on the possession of a real IP address by the server, compatible with web browsers that support asp.net. The server application software shoulders the comprehensive management of the residential automation system, encompassing configuration and establishment. It harnesses a database to uphold a repository of system constituents, opting for the utilization of XML files to archive system logs [14].
8. **RF Module for Home Automation:** The central aim of the Home Automation System is to establish an effective configuration for home automation using a remote control based on RF technology. As technological advancements continue, residences are progressively

adopting higher levels of intelligence. The contemporary inclination in housing is shifting from traditional wall-mounted switches to a centralized control structure, incorporating RF-controlled switches. The prevalent arrangement of disperse wall switches across the household poses challenges for individuals who are required to physically approach each switch in order to operate them. This inconvenience is especially pertinent for elderly individuals or those with restricted physical mobility.

The utilization of remote-based home automation presents an efficient solution through the application of RF technology. To accomplish this, an RF remote integrated with a microcontroller functions on the transmitting end, sending signals for ON/OFF commands to a corresponding receiver that communicates with interconnected devices. The action of toggling the designated switch on the remote's transmitting end harnesses wireless technology to facilitate the comprehensive activation and deactivation of loads [15].

- 9. Home Automation via a Cloud-Based Structure:** It revolves around the conception and implementation of a home gateway responsible for consolidating data originating from domestic devices. This data is subsequently transmitted to a data server situated in the cloud, where it finds storage on the Hadoop Distributed File System. This process is facilitated via MapReduce techniques, ultimately facilitating the execution of monitoring tasks for remote users. The realm of home automation is continuously advancing to encompass contemporary attributes that cater to the growing preferences of the populace.

This study unveils the formulation and realization of a home automation system that employs cloud computing as its underlying service. The existing system is structured around three pivotal components. The initial facet is the cloud server, responsible for overseeing and managing client and user data, device statuses, and information flow. The second module, the hardware interface, serves as the intermediary linking actuators and sensing devices to offer physical services. Concluding the trio is the Home Server, a hub encompassing hardware components and presenting the user interface. The central focus of this paper is on constructing web services through cloud technology, a crucial facet that ensures data security, storage, and accessibility. The current system showcases attributes of affordability, dependability, and convenience, providing a secure home automation solution for the entire household [16].

- 10. Home Automation with Wireless Sensors via Raspberry Pi and Smartphone:** The development of a Home Automation System has been realized by leveraging the capabilities of Raspberry Pi, guided by the principles and algorithms extracted from email communication. Raspberry Pi emerges as a robust, cost-effective, and potent platform ideally suited for the implementation of advanced smart home automation [17].

The approach of employing Raspberry Pi for home automation exhibits distinct advantages when compared to alternative methods. Take, for instance, the contrast with DTMF (Dual Tone Multi-Frequency) based home automation, where call charges pose a significant drawback. This particular issue is not a concern within the proposed methodology.

In the case of Home Automation via a web server, the need for designing a web server and the associated memory space requirements are eliminated through this

approach. This is because it utilizes the pre-existing web server service provided by Gmail. Furthermore, the system employs LEDs for indicating switching actions. The resulting system is both efficient and offers interactive flexibility [18].

### III. IMPLEMENTATION AND TESTING:

**1. Implementation:** Terminal devices like switches, lighting fixtures, fans, air conditioners, ovens, and similar appliances are imperative for the technology's utilization. Additionally, a module housing a microcontroller is essential, serving as a bridge to link with a manual switchboard, facilitating connectivity with Wi-Fi or a hotspot. The presence of a network infrastructure is equally crucial for the system's operation. To leverage mobile applications, internet access is requisite. Moreover, the Android operating system becomes mandatory for managing home appliances through mobile apps.

In cases where the user seeks to operate the switch offline, integration of an IR sensor becomes necessary, connecting it to the module. This enables offline operation, wherein a remote with a specific button emitting a light frequency detectable by the PCB module is utilized. The establishment of a cloud connection is also vital to bridge the application with the module containing ESP [19]. For authentication during login and to obtain switch statuses when the system operates offline, Firebase plays a pivotal role. It enables the retrieval of statuses once the system transitions back to online operation [20]. The proposed system's operational workflow is depicted in Figure 1.

#### Implementation Environment for the Proposed System is as Follows:

- **Front-End:** For crafting the user interface within the Android application, XML programming language is employed, primarily utilized for design endeavors. Additionally, a cloud connection is essential to establish a link between the circuit and the application.
- **Back-End:** In the application's backend, Java serves as the programming language of choice. Alongside these, the Arduino microcontroller is coded using the C language. Furthermore, the C programming language is employed to develop the code responsible for recognizing different frequency lights emitted by the remote. Android Studio and Arduino IDE are the designated platforms for writing this code.
- **Hardware:** Printed Circuit Board (PCB) finds application in circuit construction. The Arduino microcontroller selected for this project is the ESP 8266. The circuit components include transistors, resistors, and capacitors. Incorporation of an IR Sensor facilitates remote control of the module.

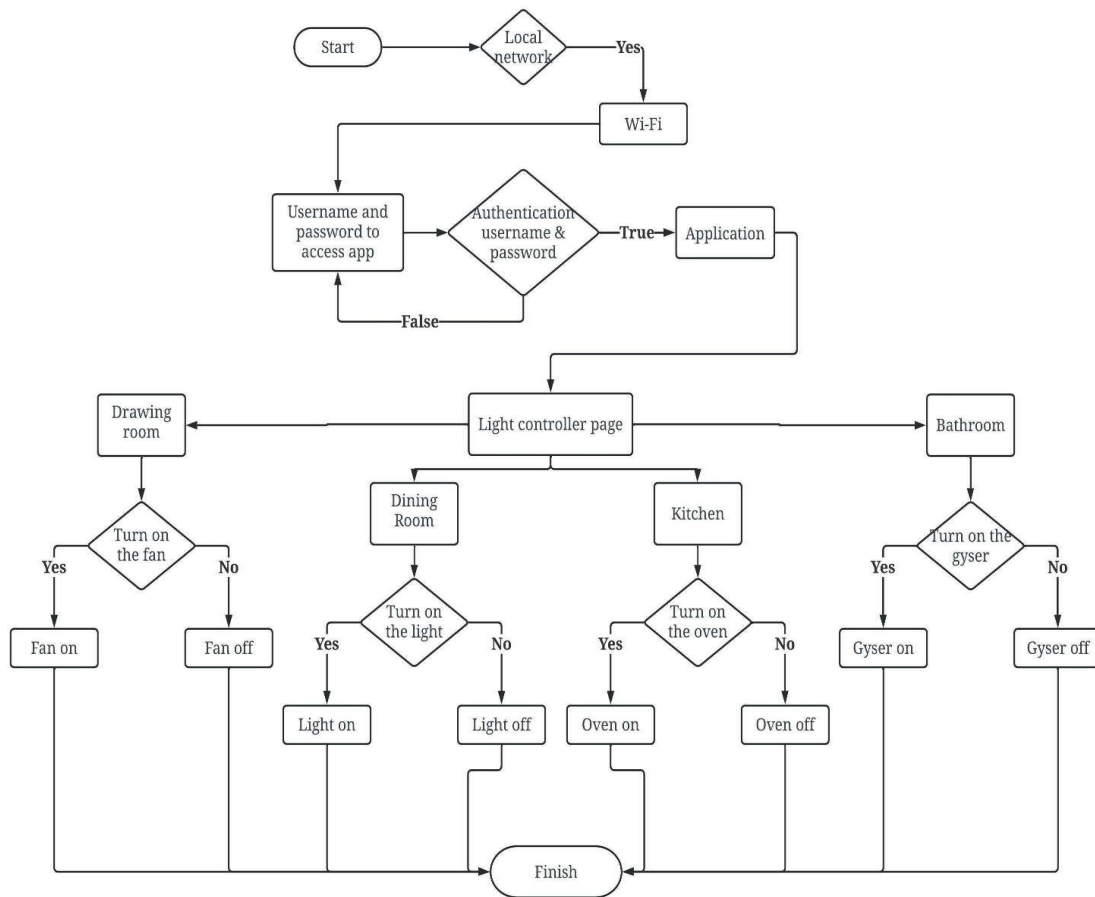

**Figure 1:** System Flow of Proposed Work

## 2. Testing Plan

- Application Testing and Analysis:** The Smart Switchboard system's application elements slated for testing encompass the MQTT server and the mobile application. The server testing process entails verifying the successful implementation of various server facets. This encompasses functions like establishing internet connections with other devices and ensuring robust data security during inter-device communication. Meanwhile, the mobile application's examination will be executed within Android Studio. This software development platform serves as the comprehensive framework for coding the entire Android application. Notably, the tool offers an advantageous feature: the capacity to simulate the application using an emulator on an Android device.
- Physical Testing and Analysis:** The hardware elements of the Smart Home system that warrant testing encompass both the sensors integrated into the devices within the Smart Home environment and the Raspberry Pi development boards employed for system implementation. The assessment will involve scrutinizing the connections between sensors and the board to verify the optimal performance of the interconnected devices. Furthermore, the backup power systems will undergo testing to validate their capacity for sustaining device operations during periods of power uncertainty.

- **Testing Strategy:** Testing the compatibility between sensors and protocols: Protocol testing ensures effective communication and interaction between servers and devices. The Wi-Fi IoT protocol is examined to ascertain its compatibility with devices, ensuring seamless operations.
- **Device Security Testing:** This testing is conducted at multiple susceptible junctures, encompassing device authentication, data gathering, data transmission, device software, and other aspects. This testing effectively safeguards against potential risks such as data breaches, cyber-attacks, and device malfunctions.
- **Product Variant Testing:** As a component of this process, testing is executed across diverse product generations encompassing multiple iterations of firmware and operating systems, such as Android. An array of hardware and software combinations is assessed, tailored to the specific usage and functionalities of each device.
- **Device Functionality Testing:** Both hardware and software undergo this form of testing to validate whether the device operates as intended.

Frequently, device virtualization and simulation are employed to reduce infrastructure expenses.

#### IV. RESULTS AND DISCUSSIONS

The ability to remotely control household appliances from anywhere in the world is a key advantage of the smart switchboard. This feature not only adds convenience but also significantly enhances accessibility, especially for individuals with physical disabilities. It empowers them to manage their homes independently and efficiently. The implementation environment for the proposed smart switchboard system plays a crucial role in its functionality and performance. The choice of programming languages and platforms for the front-end and back-end, as well as the hardware components used, has a direct impact on the system's capabilities.

In the front-end, the use of xml for crafting the user interface within the android application ensures a user-friendly design. Additionally, the integration of a cloud connection is vital for establishing a seamless link between the circuit and the application, enabling remote control. On the back-end, the choice of java for the application's programming language and c for coding the Arduino microcontroller showcases a well-rounded approach. Android studio and Arduino ide serve as robust development platforms for creating the necessary code. This comprehensive approach ensures that both the mobile application and the microcontroller operate efficiently.

The hardware components, including the esp. 8266 microcontrollers, printed circuit board (pcb), and ir sensor, are key elements in the system's hardware implementation. These components facilitate the remote control of household appliances and contribute to the system's overall functionality.

In terms of testing, a thorough plan is outlined, covering application testing and analysis, physical testing and analysis, compatibility testing, device security testing, product



variant testing, and device functionality testing. These testing strategies ensure that the smart switchboard system functions as intended, with an emphasis on security, compatibility, and performance. Additionally, the use of virtualization and simulation in device functionality testing demonstrates a cost-effective approach to validating system functionality.

Smart switchboards are an integral part of the larger smart home ecosystem. They seamlessly integrate with various technologies, including wireless communication, sensors, monitoring, and tracking systems. This integration allows for a holistic approach to home security and control, enhancing overall efficiency and safety. The implementation of smart switchboards supports the creation of cost-effective and adaptable smart homes. These systems enable homeowners to make real-time adjustments to environmental conditions, leading to energy conservation and error rectification. The result is not only increased convenience but also potential cost savings in the long run. The use of a singular identification and password simplifies the authentication process, reducing unnecessary steps and enhancing security. This ensures that only authorized users can control the smart switchboard and connected appliances, mitigating potential security risks.

Overall, the chosen implementation environment and testing plan contribute to the reliability and robustness of the smart switchboard system, making it a valuable addition to home automation and remote control of household appliances.



Figure 2: UI Design 1

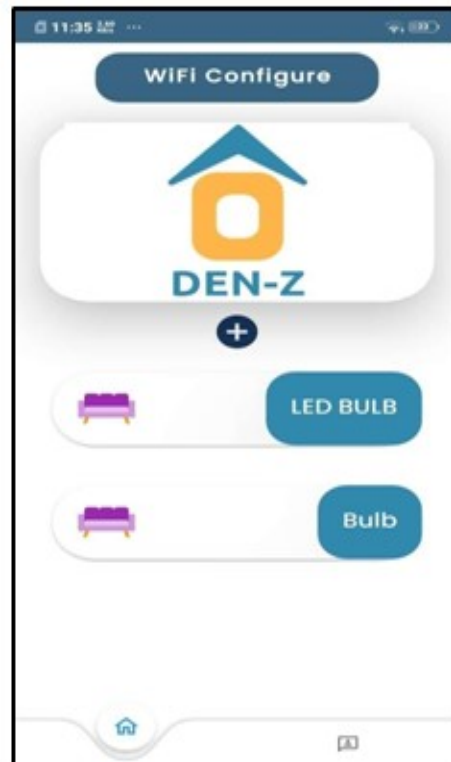

Figure 3: UI Design 2



Figure 4: UI Design 3

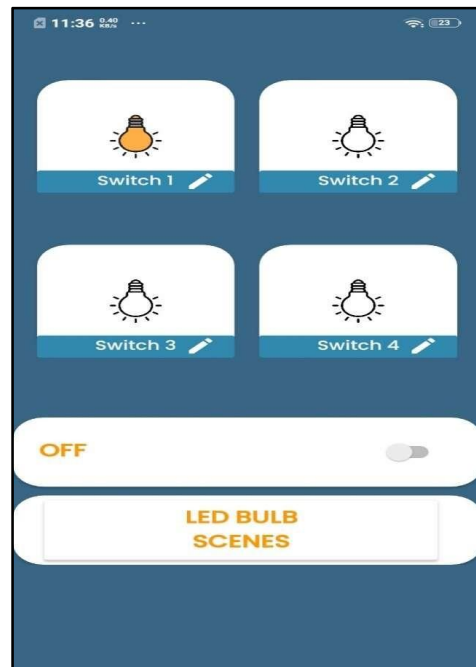

Figure 5: UI Design 4

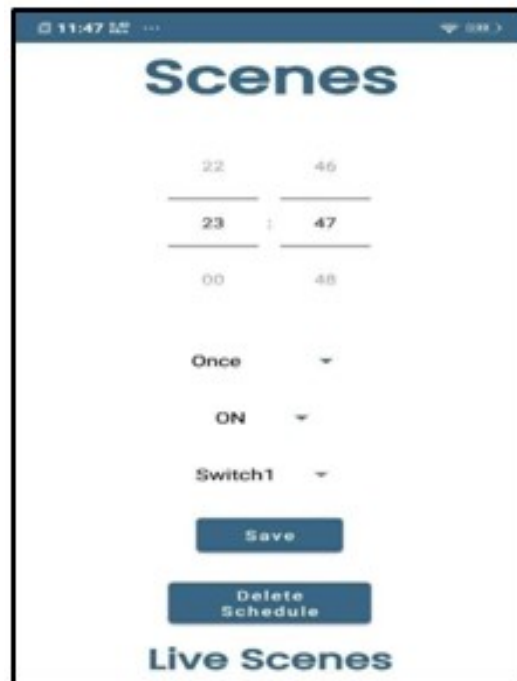

Figure 6: UI Design 5

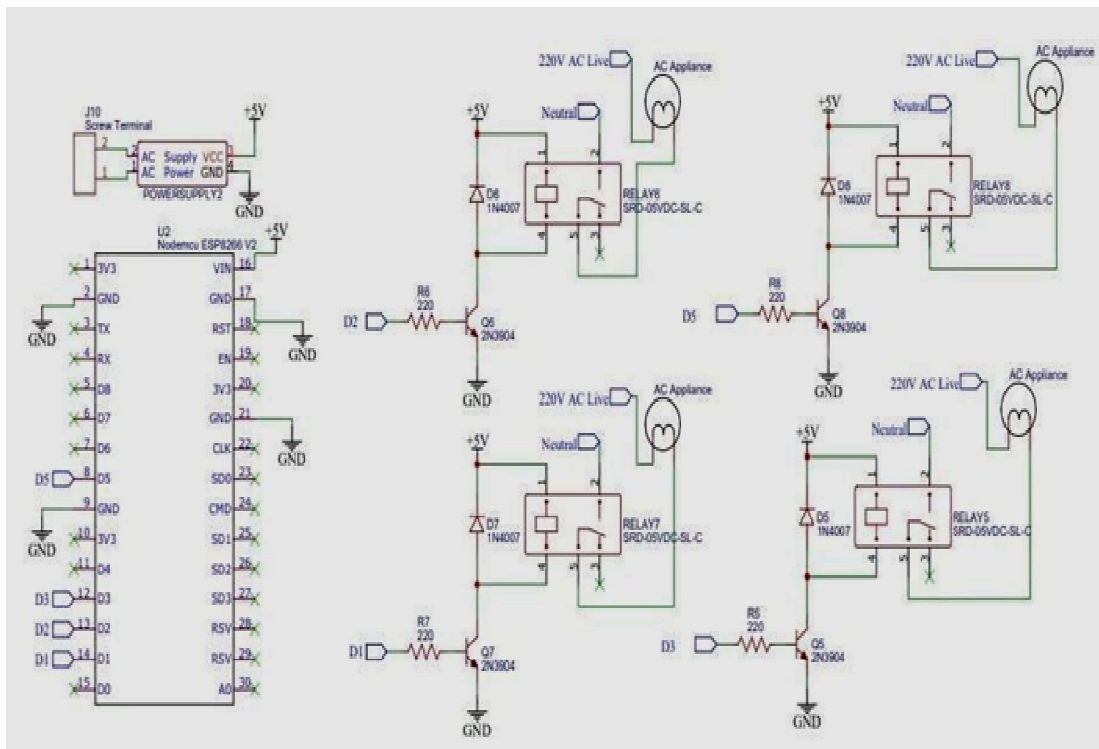

Figure 7: Circuit Diagram

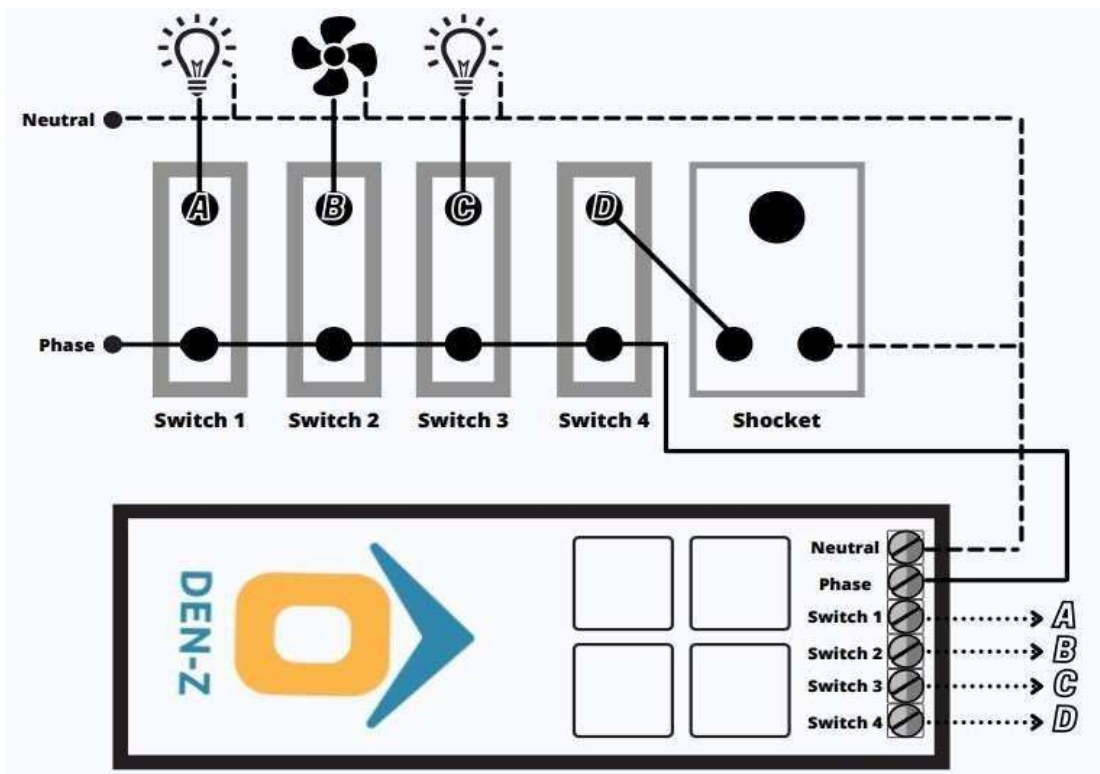
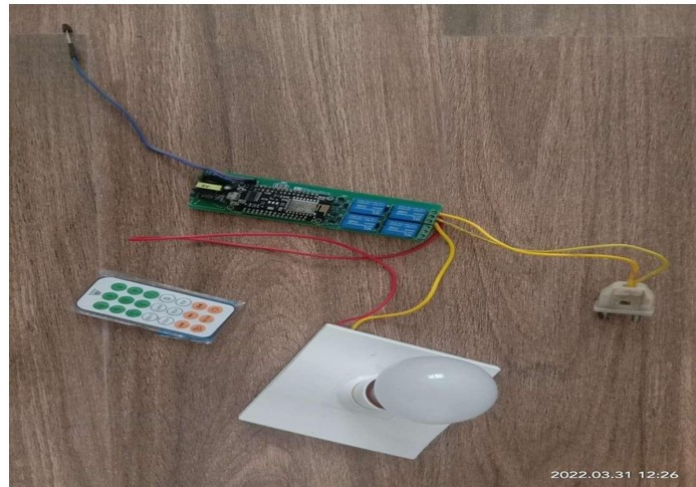

Figure 8: Connection Diagram



**Figure 9:** Working Model

## V. CONCLUSION

The smart switchboard forms an integral part of home automation, enabling the remote control of household appliances from any corner of the globe. It serves as a valuable tool for individuals with physical disabilities and those seeking a more luxurious lifestyle. Within a smart home ecosystem, wireless communication, sensors, monitoring, and tracking are interconnected. A smart home encompasses a comprehensive framework of diverse technologies and applications designed to offer easy home security and control.

Through the implementation of this system, the creation of cost-effective and adaptable smart homes becomes feasible, allowing adjustments to environmental conditions while conserving energy and rectifying errors. A singular identification, paired with a password, simplifies the authentication process, minimizing unnecessary steps. In the future, the application has the potential to be enriched with additional features. These may involve regulating light intensity via both the application and remote control, manipulating air conditioning temperature, and managing fan speed, among other capabilities.

## REFERENCES

- [1] Alam, Tanweer; Salem, Abdulrahman A.; Alsharif, Ahmad O.; Alhujaili, Abdulaziz M. (2020). Smart Home Automation Towards the Development of Smart Cities. TechRxiv. Preprint. <https://doi.org/10.36227/techrxiv.12657185.v1>
- [2] Kamble, Diksha. (2021). Smart Automation System for Controlling Appliances using Mobile Device. International Journal for Research in Applied Science and Engineering Technology. 9. 2873-2875. 10.22214/ijraset.2021.35589.
- [3] Machorro-Cano, I., Alor-Hernández, G., Paredes-Valverde, M. A., Rodríguez-Mazahua, L., Sánchez-Cervantes, J. L., & Olmedo-Aguirre, J. O. (2020). HEMS-IoT: A big data and machine learning-based smart home system for energy saving. *Energies*, 13(5), 1097. <https://www.xfinity.com/hub/smart-home/home-automation>
- [4] Palaniappan, S., Hariharan, N., Kesh, N. T., & Vidhyalakshimi, S. (2015). Home automation systems-A study. International Journal of Computer Applications, 116(11).
- [5] Piyare, R., & Tazil, M. (2011, June). Bluetooth based home automation system using cell phone. In 2011 IEEE 15th International Symposium on Consumer Electronics (ISCE) (pp. 192-195). IEEE.
- [6] Malik, N., & Bodwade, Y. (2017). Literature review on home automation system. *Ijarccc*, 6(3), 733-737.

- [8] Hwang, S., & Yu, D. (2012). Remote monitoring and controlling system based on ZigBee networks. *International Journal of Software Engineering and Its Applications*, 6(3), 35-42.
- [9] Selva Priya, B., & Geethamani, R. A Survey on Various Home Automation System and Security. *International Journal of Engineering Modern Trends in Engineering and Research (IJMTER)*.
- [10] Victoria Nicks (2009) "AI Enhances the Smart Home Security System" [http://artificialintelligence.suite101.com/article.cfm/ai\\_enhances\\_the\\_smart\\_home\\_security\\_system](http://artificialintelligence.suite101.com/article.cfm/ai_enhances_the_smart_home_security_system)
- [11] Robles, R. J., Kim, T. H., Cook, D., & Das, S. (2010). A review on security in smart home development. *International Journal of Advanced Science and Technology*, 15.
- [12] CISCO Press, "Internetworking Technologies Handbook", Chapter 51 - Security Technologies [http://users.freenet.am/~file/DownDB/CISCO\\_PDF/SecurityTechnologies\\_CISCO.pdf](http://users.freenet.am/~file/DownDB/CISCO_PDF/SecurityTechnologies_CISCO.pdf)
- [13] Shahbaz Zahr Reyhani and Mehregan Mahdavi "User Authentication Using Neural Network in Smart Home Networks", *International Journal of Smart Home*, Vol. 1, No. 2, July, 2007
- [14] Yadnya Adhiya, Shriya Ghuge, H.D Gadade "A survey on home automation system using IOT" *IJRITCC Volume\_5\_IssuesMarch\_17\_Volume\_5\_Issue\_3*
- [15] Kim Baraka, Marc Ghobril, Sami Malek, RouwaidaKanj, AymanKayssi "Low cost Arduino/Android-based Energy-Efficient Home Automation System with Smart Task Scheduling", 2013 Fifth International Conference on Computational Intelligence, Communication Systems and Networks.
- [16] YunCui, MyoungjinKim, YiGu, Jong-jinJung, and HankuLee, "Home Appliance Management System for Monitoring Digitized Devices Using Cloud Computing Technology in Ubiquitous Sensor Network Environment", Hindawi Publishing Corporation *International Journal of Distributed Sensor Networks* Volume 2014, Article ID 174097
- [17] HayetLamime and HafedhAbid," Remote control of a domestic equipment from an Android application based on Raspberry pi card", *IEEE transaction 15th international conference on Sciences and Techniques of Automatic control & computer engineering - STA'2014*, Hammamet, Tunisia, December 21-23, 2014.
- [18] Jan Gebhardt, Michael Massoth, Stefan Weber and TorstenWiens, "Ubiquitous Smart Home Controlling Raspberry Embedded System", *UBICOMM: The Eighth International Conference on Mobile Ubiquitous Computing, Systems, Services and Technologies*, 2014.
- [19] Pereira, R. I., Jucá, S. C., & Carvalho, P. C. (2019). IoT embedded systems network and sensors signal conditioning applied to decentralized photovoltaic plants. *Measurement*, 142, 195-212.
- [20] Singh, R. R., Yash, S. M., Shubham, S. C., Indragandhi, V., Vijayakumar, V., Saravanan, P., & Subramaniaswamy, V. (2020). IoT embedded cloud-based intelligent power quality monitoring system for industrial drive application. *Future Generation Computer Systems*, 112, 884-898.

