

# VOICE CONTROLLED SMART ROBOTIC VEHICALE (VCSR)

## Abstract

Vehicles are currently manually operated, and the driver is responsible for all functions. Every action, including starting and stopping, applying the brake, changing gears, accelerating, and changing direction, calls for human effort[1]. However, in this day and age, new technologies have been created that can be combined with traditional automobiles to create new smart vehicles. With the help of today's technology, these wonderful concepts are no longer just fantasies[1] but are becoming reality in every industry as our technology continues to grow and change dramatically on a daily basis. We can learn something new every day that facilitates our work, improves its correctness and efficiency, and raises our standard of living[2].

**Keywords:** gears, accelerating, traditional automobiles, smart vehicles, fantasies, dramatically

## Authors

### **Pothala Mutyalu Naidu**

Assistant Professor  
Department of CSE(AI&ML)  
Vignan Institute of Technology and Science  
Hyderabad, Telangana, India  
pмнаidu.vits@gmail.com

### **Divya Sai Leela Amrutha**

UG Scholar  
Department of CSE(AI&ML)  
Vignan Institute of Technology and Science  
Hyderabad, Telangana, India  
divya.sai.leela.amrutha.26@gmail.com

## I. INTRODUCTION

The concept is to build a smart robotic car that can be operated autonomously using voice commands from a smartphone. These kinds of gadgets are frequently referred to as Speech Controlled Automation Smart Systems (SCASS)[3]. There are numerous publications that demonstrate how a smart phone application can be used to communicate between vehicles. An excellent interface for remotely managing the vehicle is a smart phone app[3]. Many of its features can be useful for brand-new developments.

The primary goal is to create a voice-controlled smart robotic vehicle that can be driven forward, stopped, turned to the left or right, and moved at a certain pace. Using Embedded, the controlling programming is carried out in the Arduino IDE[3].

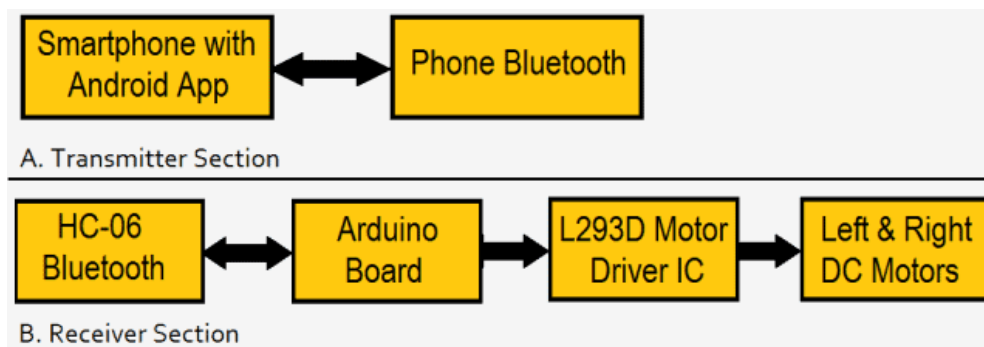

**Figure 1:** Block diagram for Voice controlled smart robotic Vehicle

## II. HARDWARE DESCRIPTION

1. **VCSRVR Circuit:** The VCSRVR gadget uses vocal commands to interact with objects nearby. Whether it's a smart house, speech-activated device, or voice-activated comfort equipment in a robotic vehicle, voice control[4] is being utilized more and more frequently in daily life. If voice control enters the production industry in several ways. There is still not enough reliability. The analysis of voice control of a collaborative smart robotic vehicle is the sole subject of this essay. This circuit focuses on the repeatability, accuracy, and dependability of voice commands in robot-human collaboration. For speech control of a collaborative smart robot, the research identifies the voice commands and best voice commands.

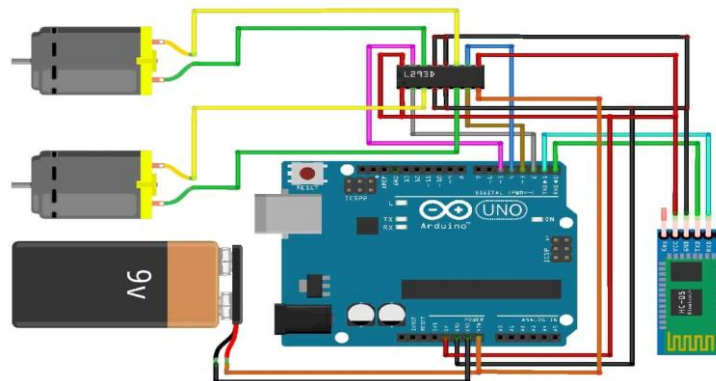

**Figure 2:** Circuit Diagram of Voice controlled smart robotic Vehicle

- 2. Microcontroller:** The device that uses VCSRVR a gadget that controls an entire system is called a microcontroller. Bluetooth chips and DC motors are connected to the microcontroller through wires. In The VCSRVR apparatus As input to the controller, the voice data are transmitted over Bluetooth from an Android smartphone. The robot vehicles' DC motors[4] are controlled in accordance with this. The smart robotic vehicle in the project (VCSRVR) can be controlled to travel in all four directions using a smartphone. By using an android application like BT Voice Control for Arduino, the robot can move (forward, back, left, right, and stop).

The device that uses VCSRVR The robotic vehicle receives commands from the micro controller (AT89S52) for control. The project (VCSRVR) includes a microcontroller, a voice recognition module, a DC motor, and

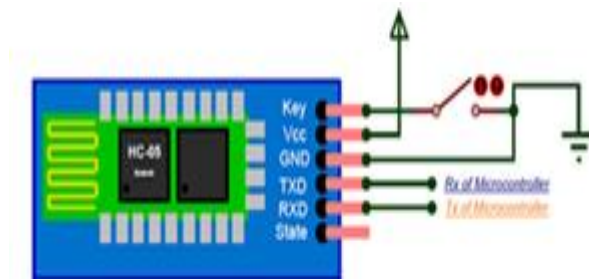

**Figure 3:** Micro controller of AT89s52

In this project (VCSRVR), AT89S52 C was used. The AT89S52 is an 8-bit CMOS microcontroller with 8000 bytes of in-system programmable Flash memory that has low power consumption and great performance.

The device is made using Atmel's high-density non-volatile remembrance technology and is compatible with the 80C51 ordinance instruction set and pin out standards used in the industry.

- 3. RPS:** A Regulated Power Supply (RPS)[5] is an integrated circuit that transforms uncontrolled (AC) Alternate Current into continuous (DC) Direct Current. It includes a rectifier that changes the supply from AC to DC. Its purpose is to deliver a constant voltage (or, less frequently, current) to a circuit or device. To be used, it must be operated within specific power supply parameters. Despite being alternating or unidirectional, the output from the RPS is essentially continuously DC (Direct Current).
- 4. Bluetooth Module:** The device that uses VCSRVR The Bluetooth TTL (Transistor Transistor Logic) modules[5] are designed for serial communication, while the Bluetooth modules are typically hardware units that offer a wireless product to operate with the PC (SPP - Serial Port Profile). Without using a serial cable to connect to our computer, it enables our intended device to send and receive TTL (Transistor Transistor Logic) data via Bluetooth protocols. The device that uses VCSRVR The firmware for the Master and Slave integrated Bluetooth serial modules in the Bluetooth HC-03 and HC-05 allows you to change the Master and Speed-Control mode at any time. Commercial grade items are HC-05, while industrial grade products are HC-03.



**Figure 4:** Bluetooth Module HC-05

- 5. Usbasp Driver:** The device that uses VCSR A USB in-circuit programmer for Atmel AVR controllers is called the USBasp. An ATmega8 and a few passive components are included. The VCSR device does not require a unique USB controller because the programmer uses a firmware-only USB driver.
- 6. Motors:** Virtually every mechanical motion that we can see around us is carried out by an electric motor, according to the VCSR gadget. Using electric machinery is a convenient way to convert energy. The VCSR device generates mechanical energy from electrical energy using motors. Hundreds of everyday devices that we use are accustomed to being powered by electric motors. There are numerous sizes of motors for the VCSR gadget. In the industry, very large motors that can handle loads of thousands of Horsepower are frequently used.



**Figure 4:** DC Motors

- 7. Wheels:** When a moment is applied by a torque or gravitational force, a wheel, which is a simple device, circles around a circular block of strong and hard material. When the wheel is positioned beneath a load-bearing platform, it may transfer enormous loads because it rotates on the horizontal axil.



**Figure 4:** Wheels

### III. SOFTWARE DESCRIPTION

The VCSR device uses the Arduino IDE software, also known as the Arduino Integrated Development Environment (IDE), which includes a text editor for creating, debugging, and compiling code as well as a message area, a text console, a toolbar with buttons for frequently used operations, and a number of menus. In order to talk with and

embed programs in devices, it links to Genuine hardware and Arduino. Sketches are programs created with the Arduino Software (IDE).

#### IV. IMPLEMENTATION

The Voice Controlled Smart Robotic Vehicle (VCSRVR) project makes it possible to drive robots using voice commands obtained from an Android application. The Bluetooth RF transmitter transforms the application's orders into digital signals for the robot's range (about 100 meters)[5]. The data is put into the microcontroller at the receiver end, where it is decoded by the receiver and used to operate the DC motors for the required tasks. The intelligent robot responds to commands after obtaining data and moves appropriately in the right direction depending on voice commands.

We created an Android application named SMART VOICE with the help of the app. The app has a Bluetooth connection feature as well as a display of Bluetooth settings. SMART VOICE SHOWS has developed an Android application. We used the app to create the SMART VOICE Android app[6]. You can use the app to connect through Bluetooth and perform operations using the Bluetooth settings on your phone.

The following is sample code:

```
if(!strcmp(msg,"front"))
void forward_Move () {
  motor1.setSpeed(155);
  motor1.run(FORWARD);
  motor2.setSpeed(155);
  motor2.run(FORWARD);
  motor3.setSpeed(155);
  motor3.run(FORWARD);
  motor4.setSpeed(155);
  motor4.run(FORWARD);
  delay(1500);
  motor1.run(RELEASE);
  motor2.run(RELEASE);
  motor3.run(RELEASE);
  motor4.run(RELEASE);
}

void backward_Move () {
  motor1.setSpeed(155);
  motor1.run(BACKWARD);
  motor2.setSpeed(155);
  motor2.run(BACKWARD);
  motor3.setSpeed(155);
  motor3.run(BACKWARD);
  motor4.setSpeed(155);
  motor4.run(BACKWARD);
  delay(1500);
  motor1.run(RELEASE);
```

```
motor2.run(RELEASE);  
motor3.run(RELEASE);  
motor4.run(RELEASE);  
}
```

## V. RESULTS

Our primary plan is to create some sort of menu-driven control for our robotic vehicle, with the menu being voice-driven. The following voice commands will be used to interact with the robot.

Robot that can accomplish the following basic tasks:

1. start
2. forward
3. back
4. right
5. left
6. stop (stops robot run)

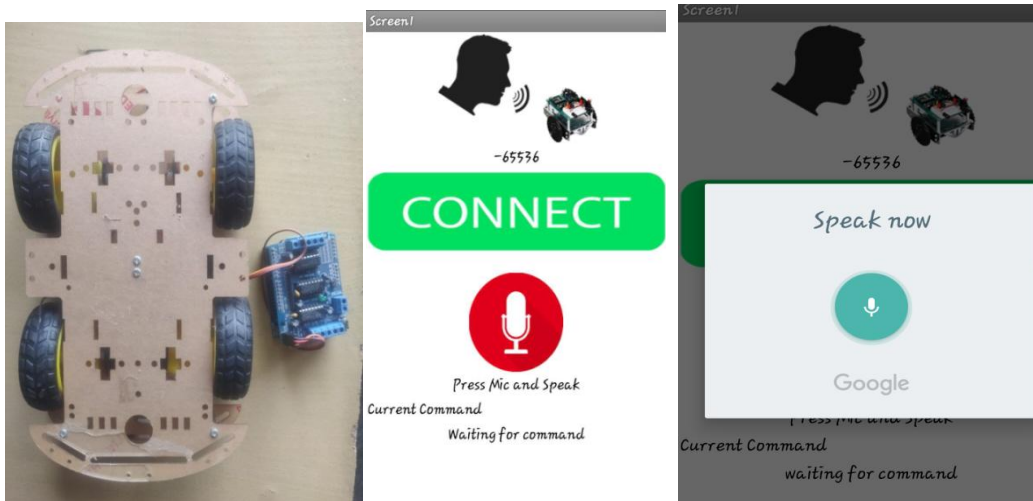

**Figure 6:** VCSR- CAR **Figure 7:** Mobile App of View1 **Figure 8:** Mobile App of View2

## VI. CONCLUSION AND FUTURE SCOPE

Such a robotic system is designed to assist people with motor disabilities in using mobile phones to manage various household items. The concept ought to be extended to Bluetooth device control. In the future, we will use a wireless channel that is encrypted and decrypted. Some of these software programmers can be created to operate home appliances, robotic devices, speech-to-text translation, robotic movements, and many other things. Future businesses, home auto industries, auto industries, and agriculture are all produced by intelligent robotic vehicles. to boost production by lowering worker efficiency, labor efficiency, and accuracy.

In future implement of our project as follows:

1. This discovery was used to a Bluetooth module for short range. Long-distance connectivity with the robot will be made possible by the use of long-range modules, additional connectivity devices, and new technologies.
2. Schedules for sleep and waking up can be integrated into this gadget for power optimization.
3. Robotic cars can use image processing technology to recognize colors and objects even when they are moving.
4. A thermal camera can be fitted to detect heat, cold temperatures, and weather forecasts emitted by bodies of water.
5. To integrate an automatic targeting system for tracking targets into intelligent robots.

## REFERENCES

- [1] M. Meghana et al,2020, Hand gesture recognition and voice controlled robot, Materials Today: Proceedings, 2214-7853.
- [2] Bhanu chandu, Kirupa Ganapathy,2020, Voice Controlled Human Assistance Robot, International Conference on Advanced Computing & Communication Systems (ICACCS), 978-1- 7281-5197-7/20.
- [3] Linda John et al,2020, Voice Control Human Assistance Robot, National Conference on Technical Advancements for Social Upliftment, Proceedings of the 2 nd VNC; VNC-2020;
- [4] T. Thivagar, A. Sriram,2020, Hand Gesture ,2020,Voice Controlled Smart Vehicle, International Journal of Modern Science and Technology, ISSN: 2456-0235.
- [5] Dyah Ayu Anggreini Tuasikal, Hanif Fakhurroja, Carmadi Machbub,2018, Voice Activation Using Speaker Recognition for Control
- [6] Rahul Kumar, Ushapreethi P, Pravin R. Kubade,Hrushikesh B. Kulkarni “Android Phone controlled Bluetooth Robot” International Research Journal of Engineering and Technology (IRJET) Volume: 03 Issue: 04 | Apr-2016