

CURRENT TENDS IN MICRO FORMING

Abstract

"In recent times, there have been significant strides in micro manufacturing technologies, playing a pivotal role across a spectrum of applications, from heavyweight industrial sectors such as automotive and aerospace to commonplace electronics components and medical apparatus. Amidst the array of micro manufacturing technologies, this chapter takes a closer look at micro forming technologies, given their manifold advantages over alternative methods. These benefits encompass minimal material wastage, exceptional mechanical properties, and their aptness for high-volume manufacturing. This chapter provides an outline of the principal research conducted in the domain of micro forming technologies, systematically categorized into four primary clusters: Applications, processes, tools, and equipment. Moreover, the difficulties linked with miniaturization within each of these core clusters are also investigated."

Keywords: Micro forming, micro presses.

Authors

Dr. Prof. Anand Dhruv
Professor and Head
Government Engineering College
Patan, At-Katpur, Gujarat, India.
dhruv_30@rediffmail.com

Kapil Banker
Assistant Professor
Department of Mechanical Engineering
Government Engineering College
Palanpur, Gujarat, India.
219999919024@gtu.edu.in

Manish Parmar
Research Scholar
Gujarat Technological University
Ahmedabad, Gujarat, India.

Sapna Solanki
Research Scholar
Gujarat Technological University
Ahmedabad, Gujarat, India.

I. IMPORTANCE OF MINIATURIZATION AND CONCEPT OF MICRO FORMING

In current era times, there has appeared a massive demand for micro-scale products spanning diverse realms of technology and manufacturing. These encompass MEMS, telecom sector, bio-technology, medicine, sensor industries, microelectronics. This upsurge is propelled by the overarching trend towards miniaturization and the escalating integration within an expanding array of applications. Consequently, a substantial market has arisen for mechanical components and metallic micro parts, necessitating large-scale production.

For instance, mobile phones have undergone successive reductions in size across generations, accompanied by the incorporation of added functionalities like unified controllers and music players. Notably, a wristwatch embedded with a micro camera has recently been unveiled, alongside a micro hard disk drive boasting a one-gigabyte size and dimensions comparable to an eggshell. (Figure 1) [Geiger et.al,2001].



Figure 1: Thin Hard Disc (IBM).

Conventionally, these intricate mechanical components have been crafted through machining techniques involving material removal processes. However, for specific applications, the utilization of metal forming processes stands out as the optimal choice for achieving miniaturization objectives. This preference stems from the inherent benefits of these processes, such as the capacity to yield net shapes or nearly net shapes, heightened productivity, reduced material wastage, superior mechanical properties, and precision. Furthermore, these methods exhibit exceptional accuracy, rendering them particularly suitable for scenarios necessitating large-scale production at economical costs. [Engel 2002; vollertsen,2004]. To achieve high-precision mass production on a microscopic scale, the evolution of micro forming technology has emerged as a pivotal advancement. This technology has garnered significance as a crucial method for manufacturing miniature-elements.

Micro forming is characterized as the process of fabricating various metal components through shaping, involving a minimum of 2 sizes within the sub-millimeter scale [Geiger 2001]. This encompasses a variety of exemplars, including pins, hooks, micro rivets, lead frames, plugs, micro cups, and assorted types of connecting elements.

II. APPLICATION OF MICRO FORMING

Over the past decade, the prevailing trajectory toward miniaturization has led to a growing requisition for diminutive metallic components. This has translated into a projected surge in revenue, escalating from 20 to 32 billion US dollars in recent centuries. [F. Vollersten et al., 2004] Prominent sectors such as medical, electronics, micro systems technology, and watch industries have all witnessed significant utilization. These industries have found crucial applications for micro-scale power-driven systems, exemplified by micro motors, micro-resonators, micro coils, micro gears, micro lead frames, and micro broadcast components. [Sawyer et al., 2004].

Additional illustrative instances of such components encompass IC-carrier pins, fasteners, micro screws, sockets, and assorted connecting elements achieved through extrusion technology. Moreover, connectors, contact springs, and lead frames, including their inner leads, are fashioned via blanking. The creation of micro cups entails micro deep drawing. Notably, progressive tools with up to 15 steps facilitate the production of items such as cups for electron guns in color television sets or shafts for mini engines. These stand as characteristic micro parts catering to diverse applications. are shown in Figure.2 [Geiger et.al, 2001].



Products made by micro-stamping (punching, bending, drawing)



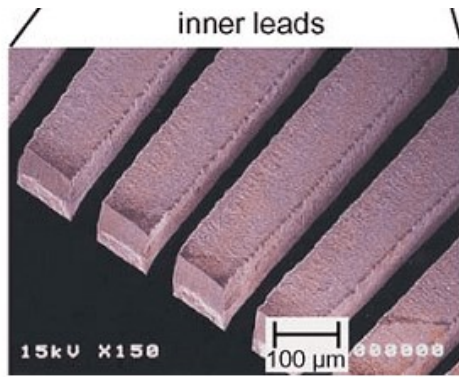

Figure 2: Leadframe (Shinko)

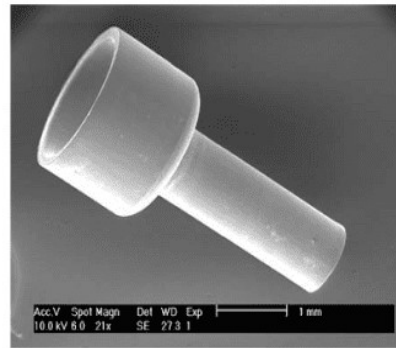

Figure 4: Shaft of a micro motor; material: SPCE steel [9]

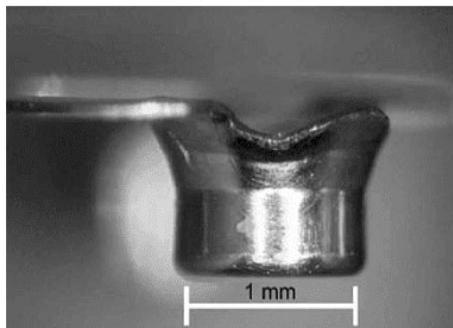

Figure 3: Cup for electron gun; material: molybdenum (Philips Components Sittard)

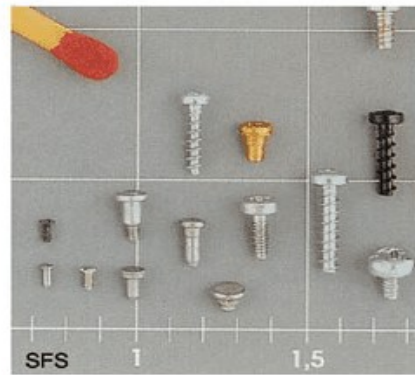

Figure 8: Micro screws (SFS)



Figure 2: Miniature Parts for Frequent Application Made by Micro Forming.

Nonetheless, the effective integration of micro forming into the commercial production of micro parts hinges on a comprehensive grasp of the multifaceted facets of

micro forming. Numerous micro-scale mechanisms of significance find appropriateness applications in these fields.

III. THE MICRO FORMING SYSTEM

To comprehend the challenges and complexities inherent in micro forming processes, and to devise effective solutions, the examination commences with a focus on the micro forming system. These categories encompass material, process, tools, and machinery and equipment. Figure 3 provides a visual representation of the variables that arise alongside the process of miniaturization, interlinked with the four designated groups. In addition to the challenges encountered in standard forming procedures, such as concerns regarding tool design, wear, and the suitable treatment of materials, micro forming introduces distinct issues intrinsically tied to the process of miniaturization. [Engel et al., 2002].

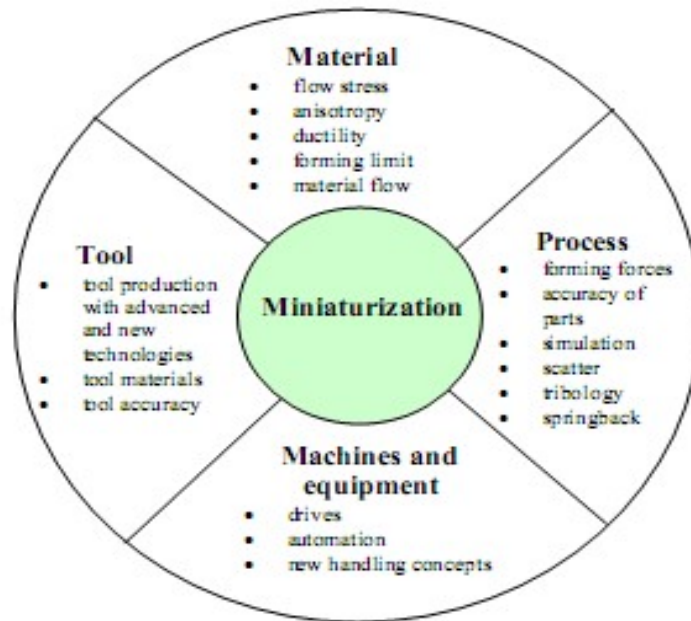

Figure 3: Variables that become Important with the Micro Parts [Engel et al, 2002]

Major issues in micro forming

Factors Influencing Material Behavior in Micro Forming

- 1. The General Size Effects:** A diverse array of materials, encompassing metals, nonmetals, and composites, has found application in micro forming. Examples include steel, titanium, copper, nickel, brass, aluminum, silicon, PZT (lead zirconate titanate), polycarbonate, and acrylonitrile butadiene styrene. [Bourell,2006]. Materials were tested, mostly brass, copper, stainless steel and aluminium having wide range of applications. Due to the inapplicability of traditional forming methods within the realm of micro forming, inquiries become imperative to quantify the size effects. Based on the similarity theory proposed by Geiger et al. (1997).

While this theory can potentially be applied to process scaling down and tooling design at the macro-scale, practical material tests and forming experiments reveal deviations in material responses that contravene the principles of similarity theory. The impact of miniaturization on flow stress has been examined through analogous tensile tests, upsetting tests, air bending experiments, and punching experiments. [Geiger et al., 1997]. Experimental findings have indicated a decline in flow stresses as miniaturization is intensified. This decrease in flow stress finds its rationale in the 'Surface Layer Model.' (Figure 4 (a)).

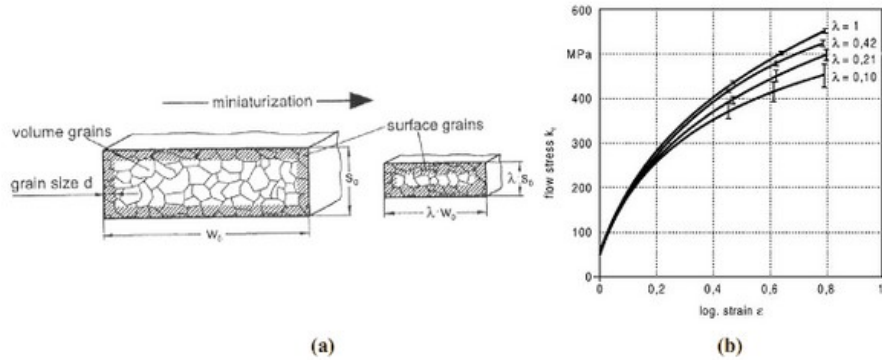
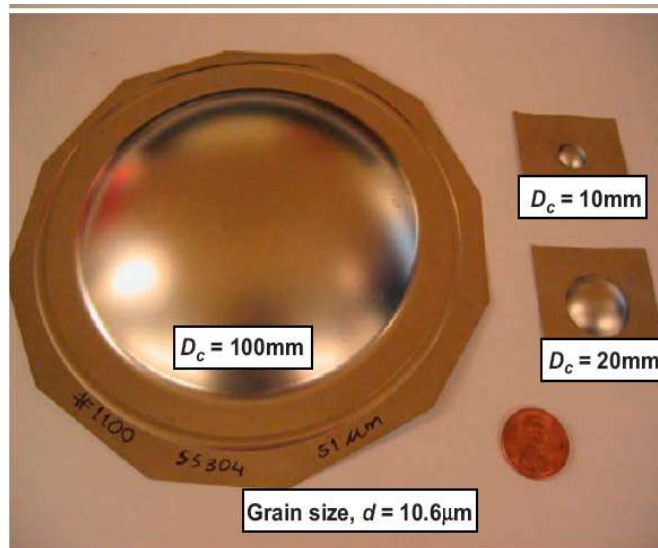
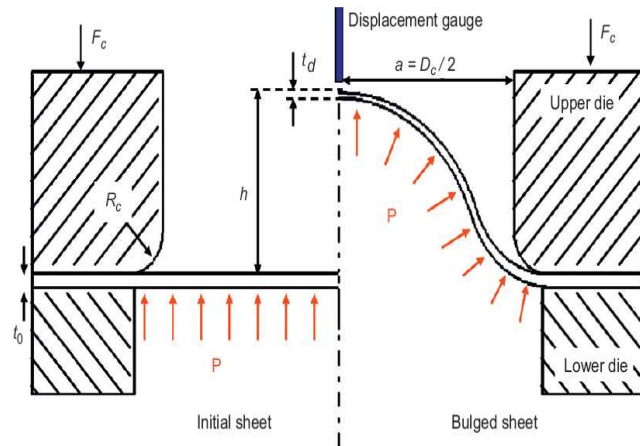

Figure 4: (a) Surface Model (B) Flow Stress Curve

The surface layer model is predicated on the observation that on small scales, materials can no longer be treated as uniform and continuous substances. This is particularly evident when the size of individual grains relative to the dimensions of the billet or blank is taken into account. In cases where micro-parts are involved, a significant proportion of grains make up the surface layer, as opposed to being entirely surrounded by other grains. This distinction arises due to the comparatively weaker constraints on the surface area, resulting in differing responses to the deformation forces.[Geiger et al., 1997]. Figure 4 (b) shows the decreasing flow stress with the increasing miniaturization. This phenomenon is likewise evident when investigating the size effect within the realm of sheet metal microforming. [Kals et al., 2000, Michel, 2003], and aluminum [Raulea,2001].

A hydraulic bulge test setup was developed by Mahabunphachai and Koç in 2008, A selection of the bulged samples is depicted in the accompanying figure. 5.



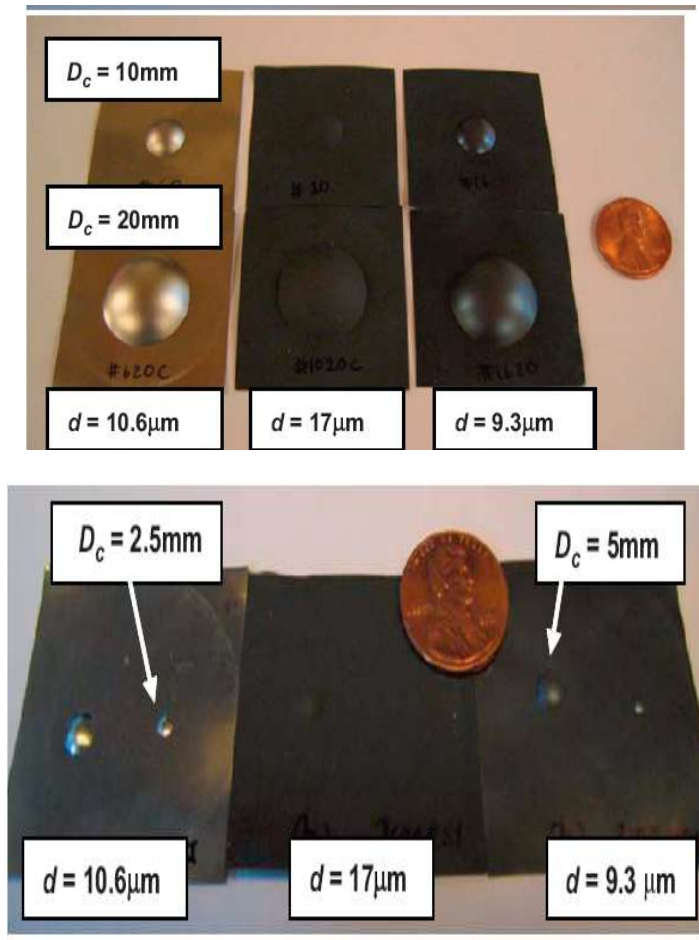

Figure 5: Hydraulic Bulge Test.(Mahabunphachai and Koç 2008)

The flow curve graphs presented in Figure 6 reveal a distinct influence stemming from the material's grain size. Notably, materials featuring larger grain sizes exhibit reduced strength—a trend that aligns with the principles of the H_p relationship. In the context of the impact of feature size, the flow curve graphs illustrate a reduction in the flow curve. Consequently, when endeavoring to shape smaller features or components, the material's response should exhibit enhanced strength.

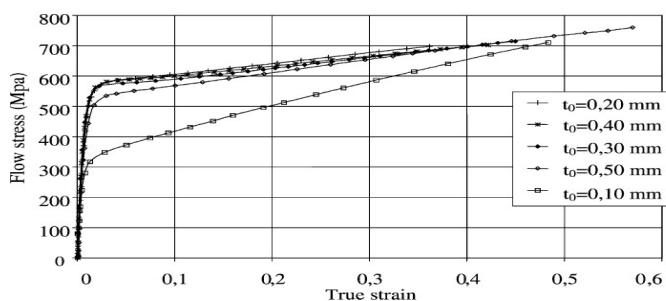

Figure 6: Flow Curves from Bulge Test on CuZn36 for Thicknesses from 0.1 to 0.5 mm

A series of bulge experiments was conducted on CuZn36 specimens, spanning various thicknesses ranging from 0.1 to 0.5 mm, (Michel and Picart in 2003). The transition in thickness from 0.5 to 0.1 mm induces alterations in the flow stress curves, as displayed in Figure 6.

- 2. Grain Size Effect:** The previously introduced "Surface Layer" model elucidates the decline in flow stress that accompanies the process of miniaturization or reduction in thickness within sheet microforming. This phenomenon is intricately connected to the proportion between grain size and sheet thickness. To investigate this effect, uniaxial tensile tests were conducted using sheets of varying thickness while maintaining a consistent grain size. [Raulea et al., 1999].

It has been revealing a consistent pattern: as miniaturization increases, both the yield strength and tensile strength exhibit a decrease. [Raulea et al., 1999]. A concise overview of the impact of N (t_0/d) on flow stress, derived from the findings documented in various sources, is depicted in Fig. 7

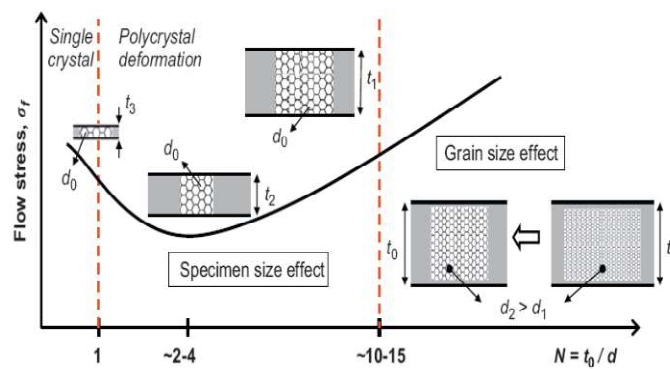

Figure 7: Grain VS. Specimen Size Effect on the Flow Stress as A Function of N

When dealing with situations involving a sparse population of grains across the thickness, distinct conditions of orientation and size within each individual grain manifest in the forming behavior. This arises because the behavior is no longer smoothed out by the presence of a large number of grains. Consequently, the scattering of results also experiences an escalation.

- 3. Effect of Friction:** Engel et al. (2002) Their investigation revealed that, under lubricated conditions with oil, the friction force intensifies with miniaturization, while in the absence of lubrication, it remains unaffected by size. Figure 8 illustrates the experimental setup, featuring a cylindrical specimen situated between a stationary and a moving punch of matching geometry. During testing, the upper punch descends, prompting the material to form two cups with distinct heights, denoted as h_u and h_l . When friction is entirely absent, both cups share identical heights. However, with increasing friction, the formation of the lower cup encounters greater hindrance. Consequently, the ratio h_u/h_l serves as a sensitive gauge for assessing friction. Notably, this ratio escalates with miniaturization. (Ghobrial, Lee et al. 1993).

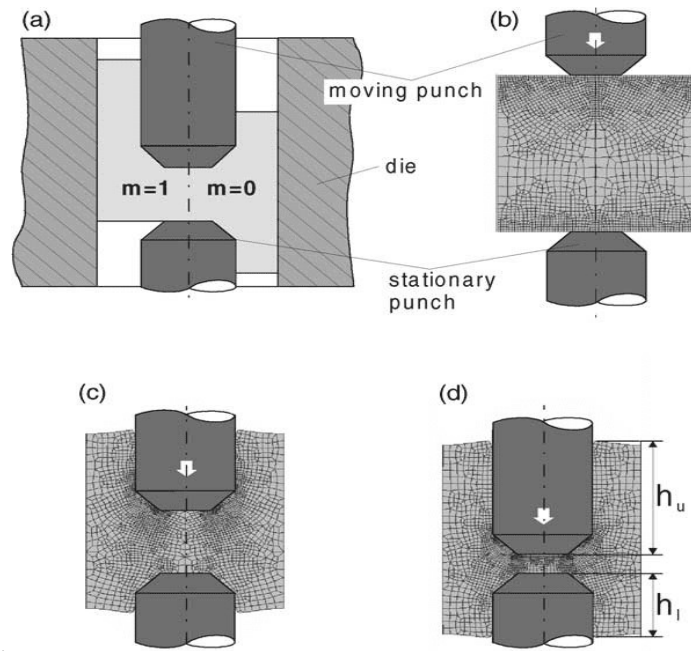

Figure 8: DCE Test: (a) Dependence of Cup Height on Friction; (b)–(d) FEM Calculation, Development of the Cups.

The frictional characteristics observed can be elucidated through the model of open and closed lubricant pockets, alternatively referred to as dynamic and static lubricant pockets (Sobis, Engel et al. 1992). When an applied forming load acts upon a lubricated workpiece surface, the asperities or "roughness peaks" begin to undergo plastic deformation. However, roughness valleys that are linked to the edge of the surface are unable to retain the lubricant and are termed "open lubricant pockets." As the normal pressure grows, the lubricant is extruded, resulting in an inability to uphold or transmit the forming load, as depicted in Figure 9.

Conversely, closed lubricant pockets lack a connection to the surface's edge. Lubricant becomes confined within these pockets and experiences pressurization during forming. This pressurized lubricant assists in transmitting the forming load, subsequently reducing the normal pressure exerted on the asperities. This reduction in pressure leads to diminished friction, as illustrated in Figure 9.

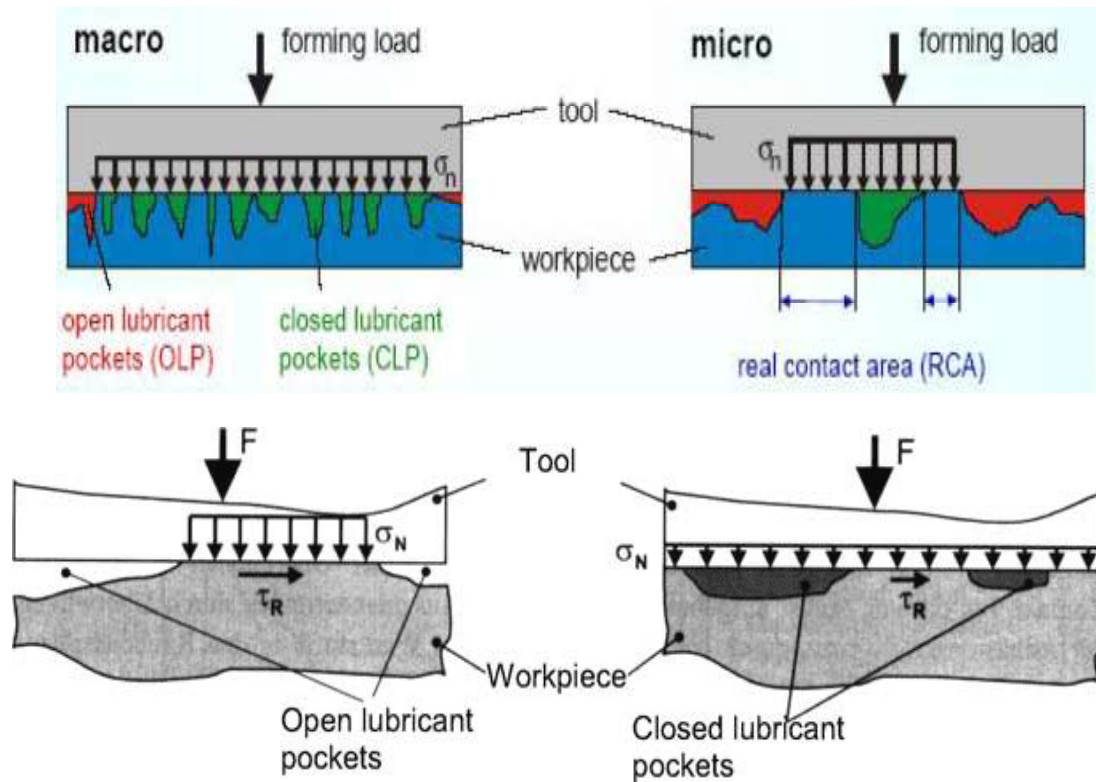

Figure 9: Open and Closed Lubricant Pockets.

In summary, the application of the model of open and closed lubricant pockets reveals that closed lubricant pockets result in reduced friction, in contrast to open lubricant pockets. When this model is extended to the previously described DCE test, a scaling effect on the ratio of open to closed lubricant pockets becomes evident, as illustrated in Figure 10. Notably, a consistent-width region (labeled as "x" in Figure .10) exists where open lubricant pockets exhibit effectiveness. As the specimen size is decreased, the proportion of open lubricant pockets escalates, concurrently leading to an increase in the friction factor. For instance, experiments involving specimens with a fixed diameter but varying height were performed, aligning with the model by demonstrating increased friction with reduced height. Further support for the model's accuracy is gleaned from experiments employing solid lubricants or even dry conditions instead of fluids. Under such circumstances, the mechanism posited by the model fails to take effect, consequently negating the occurrence of size effects.

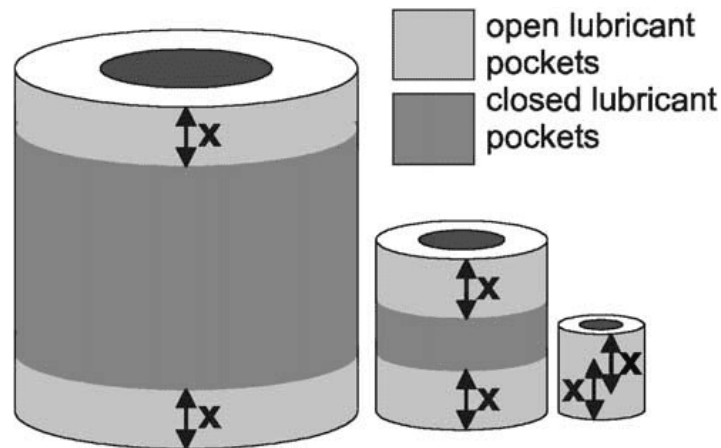

Figure 10: Effect of Miniaturization on Areas with Open and Closed Lubricant Pockets

Micro Forming Processes

1. Classification of Micro Forming Processes: Over the past 15 years, a series of significant investigations have been conducted in the field of micro forming. Many of these studies have been marked by empirical process design, aiming to address various technical challenges. (Messner, Engel et al. 1994) (Vollertsen, Hu et al. 2004)

- **Bulk Forming: Micro-bulk forming** boasts a diverse array of applications owing to its inherent advantages. The initial raw component can be readily manufactured through wire drawing, reducing diameters to the scale of tens of microns, followed by segmenting the wire into compact cylinders. Nevertheless, a notable challenge lies in the meticulous handling of these diminutive pieces within a defined timeframe and with the requisite precision.
- **Sheet-Metal Forming :** Extensive research has been dedicated to the exploration of micro-sheet-metal forming, encompassing both air bending and laser bending methodologies applied to metal sheets featuring thicknesses as low as 0.1 mm. • **Profile forming – Micro-profile** is still an unknown area in terms of research.

2. Micro Bulk forming Processes : Several metal forming processes have been effectively downsized, allowing for the systematic study of the implications of miniaturization. Bulk microforming methods, such as micro part extrusion and micro wire drawing, have received attention from researchers including Cao et al. (2004), Rosochowski et al. (2007), and Yasunori Saotome et al. (2001).

Cao et al. (2004) conducted a micro-scale extrusion experiment involving the extrusion of micro pins crafted from CuZn30 brass. These pins exhibited grain sizes of 32, 87, and 211 μm , along with diameters of 1.0 and 0.48 mm. An illustration of a deformed pin produced during extrusion, as well as the extrusion machine, is presented in Figure 9. The study revealed average maximum extrusion forces of 4.11 KN for the 32 μm samples, 3.67 KN for the 87 μm samples, and 3.64 KN for the 211 μm samples. Consistent with expectations, it was observed that smaller grain size billets necessitate higher ram forces, indicating that flow stress escalates as grain diminishes

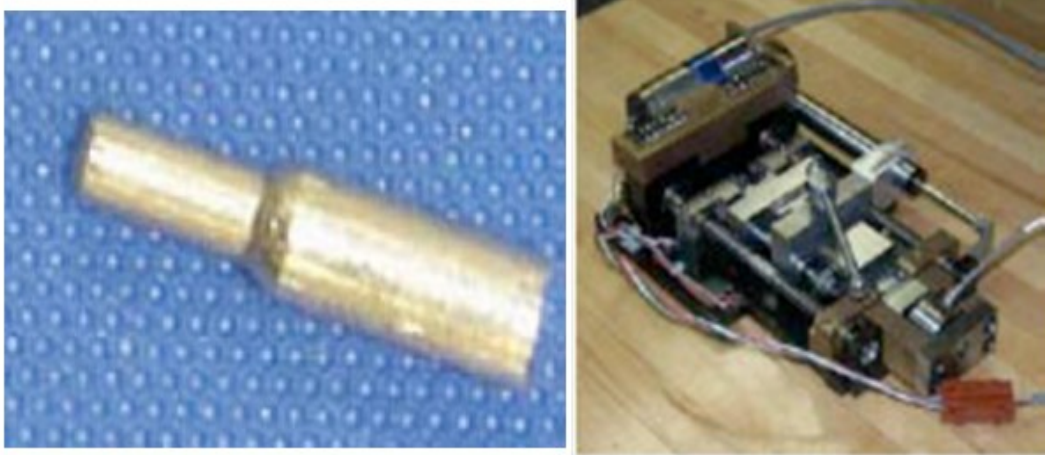

Figure 11: Extruded pin and Micro extrusion apparatus.

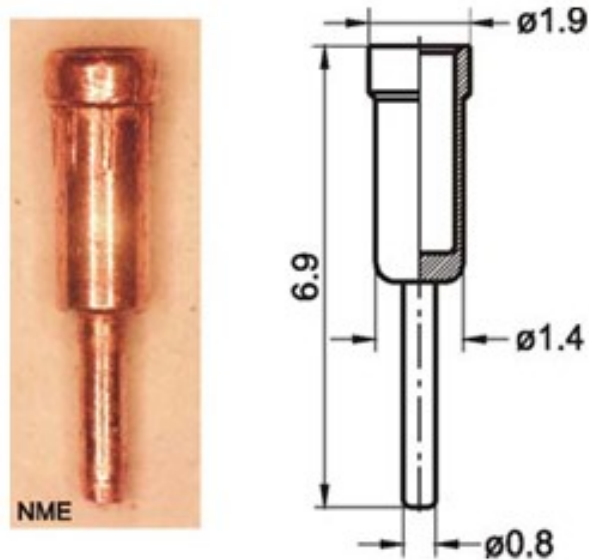

Figure 12: Extruded Copper Pin.

The most diminutive component recognized in industrial applications, crafted through a multi-stage forming process, is a copper pin that undergoes both forward rod and backward can extrusion. This pin features a shaft diameter measuring 0.8 mm and a wall thickness of 125 μm . (Figure 10)(Geiger, M.Kleiner et al. 2001).

Olejnik, Prez et al. conducted a comprehensive exploration of backward micro-extrusion utilizing commercial Al 1050. The tool set employed for micro extrusion, along with depictions of the billet (calibrated blank) and the resulting extruded cup with a wall thickness of 150 μm , are illustrated in Figure 11.(Olejnik, Presz et al. 2009)

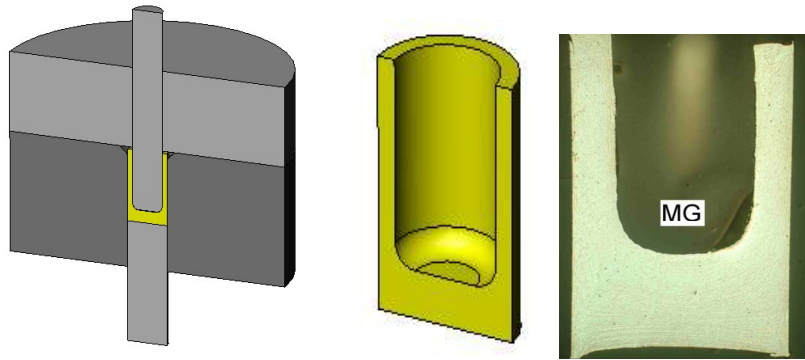

Figure 13: Tool Setup for Backward Micro-Extrusion together with the Billet and the Extruded cup.

A typical model machine (Figure 14) has been developed by Guana University, Japan [Yasunori saotome 2000] as well as Northwestern University, USA for micro extrusion process. Typical examples of extruded micro parts are shown in Figure 14 [Engel et al, 2002, Vollersten et al., 2004].

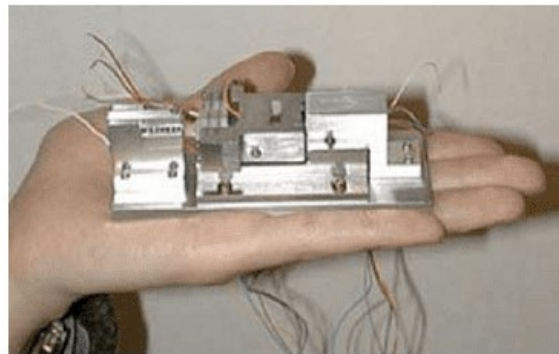

Figure 14: Micro Extrusion Machine.



Figure 15: Typical Examples of Micro Extruded Parts

Micro-gears serve as crucial actuating components extensively utilized within micro-electromechanical systems (MEMS) devices. The isothermal microforming process of micro gears was successfully executed employing a purpose-built microforming apparatus, as depicted in Figure 15. The micro gear's contour was exceptionally well-defined, and the components exhibited a surface free of burrs, as evidenced in Figure 10. The mean roughness (R_a) of the teeth's surface measured at 0.74×10^{-3} mm.

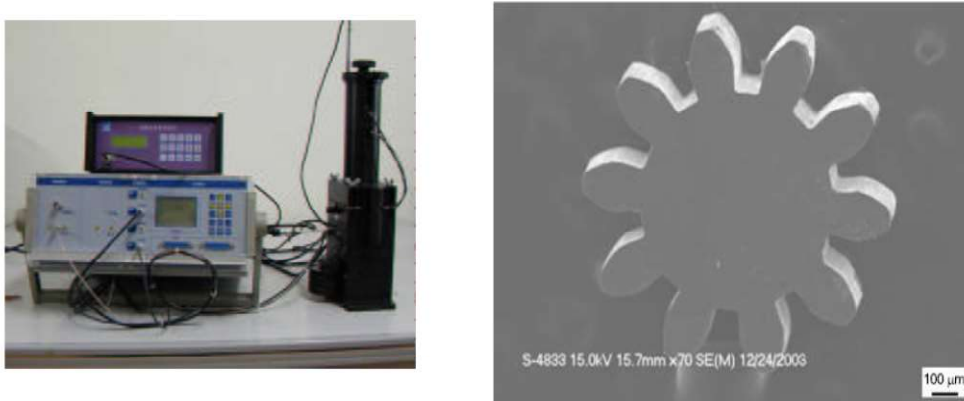

Figure 16: Photograph of the Micro Forming Apparatus and SEM Photograph of Micro Gear.

A groundbreaking hybrid process was introduced, merging the isothermal enclosed forging technique with two distinct piercing methods, to achieve the fabrication of micro-double gears (Debin, Jie et al. 2009). This hybrid forging method, in conjunction with central piercing, was subjected to extensive experimental investigations. Notably, the mini gear was successfully mass-produced using a specialized micro forming apparatus driven by piezoelectric (PZT) technology, as illustrated in Figure 18.

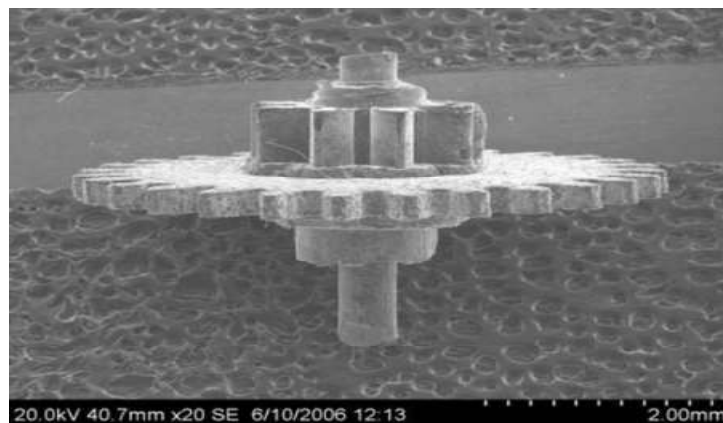

Figure 17: Formed Micro Double Gear

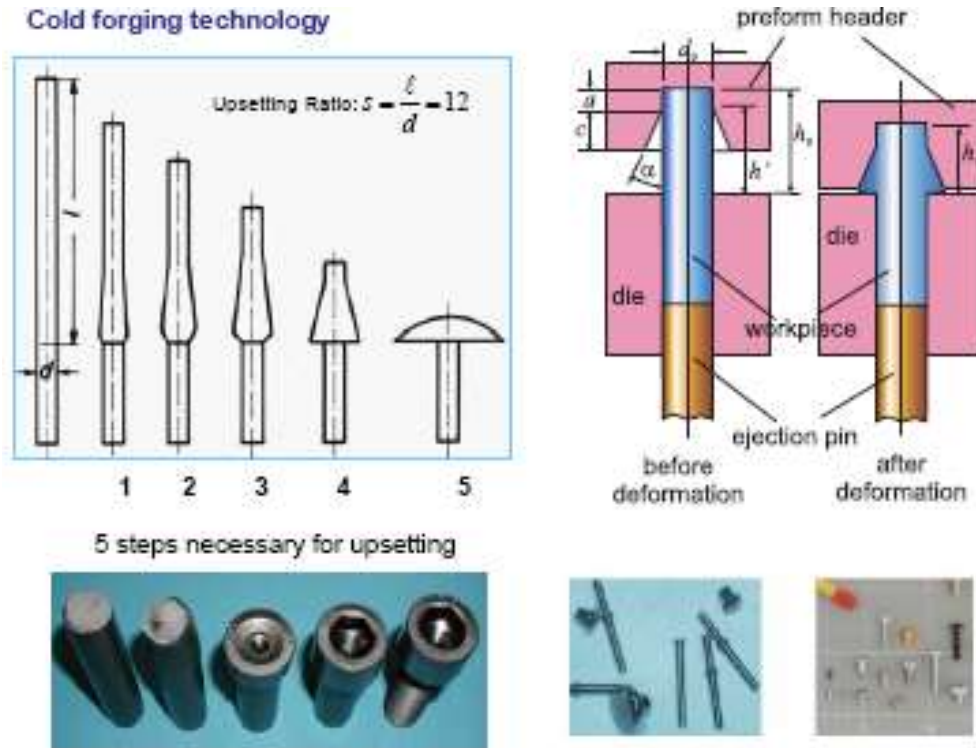

Figure 18: Products made by Cold Forging.

- 3. Micro Embossing:** Embossing technology is a commonly employed method for producing small components in microchips. This technique involves exerting high pressure through a punch onto a small material region directly on the surface, causing it to conform to the punch's shape.

The investigation into cold embossing utilizing silicon dies was conducted by Otto and Böhm [Otto, 2000; Böhm, 2001]. Otto's initial experiments utilized aluminum 99.5 as the material, embossed at room temperature with a straight channel feature. The outcome is displayed in Figure 18, showcasing the feasibility of molding structures smaller than the material's grain size without causing damage to the silicon die. Böhm's subsequent study of the cold embossing process centered on analyzing forming precision and die wear under various conditions, including different micro-geometries, applied loads, and workpiece materials. Two patterns of silicon die features were employed: complex and straight channel structures (Figure 20). The complex structure experiments employed aluminum, stainless steel, copper, and brass as blank materials. The outcomes demonstrated that complex structures could be formed with all four materials with exceptional precision (Figure 21).

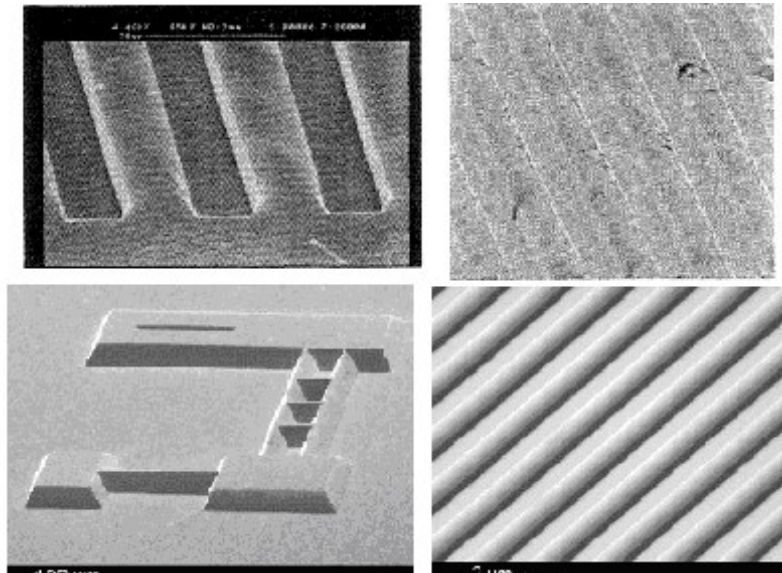

Figure 20: SEM images of Etched Side, and Embossed Gratings

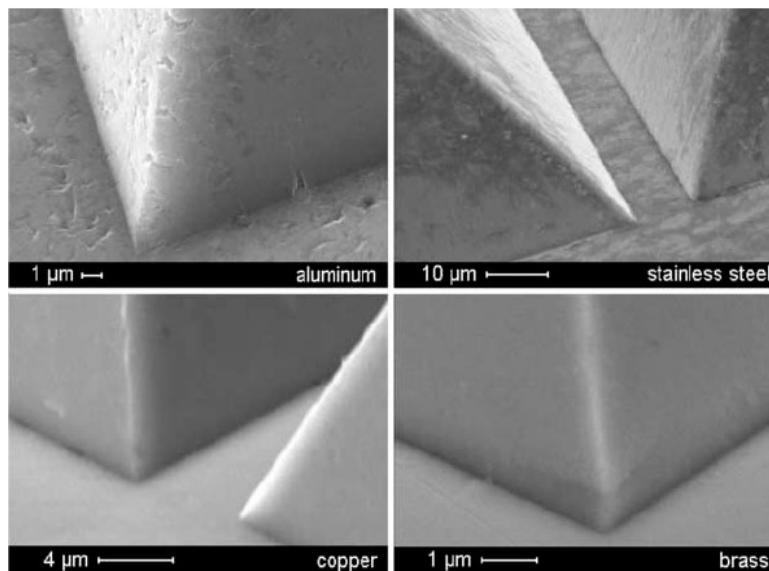

Figure 21: Detail of Complex Structure after Cold Embossing

- 4. Micro Hydroforming:** The University of Applied Sciences Cologne's Institute of Production has spearheaded the development of a pioneering hydroforming machine dedicated to the fabrication of miniature and micro-tubular components, as depicted in Figure 22. Hydroforming processes have gained significant traction in industry, primarily for producing lightweight automotive components. Nonetheless, mass production has been predominantly limited to parts with cross-sections exceeding approximately 20 mm in width. A notable gap existed in the realm of hydroforming tubular miniature and micro-components. To address this gap, a specialized machine system was devised for

forming miniature tubes, accommodating diameters as small as 0.8 mm and thicknesses as thin as 20 μm .



Figure 22: The Micro-Hydroforming Machine System.

Joo et al. conducted a comprehensive investigation into the micro-hydroforming process aimed at fabricating micro-features on thin metal sheets in 2004. The study achieved successful formation of micro-channels featuring widths of 10-20 μm and depths of 5-10 μm , employing AISI 304 stainless steel. These results were obtained using static pressures of up to 250 MPa, as depicted in Figure 20 (Joo, Oh et al. 2004).

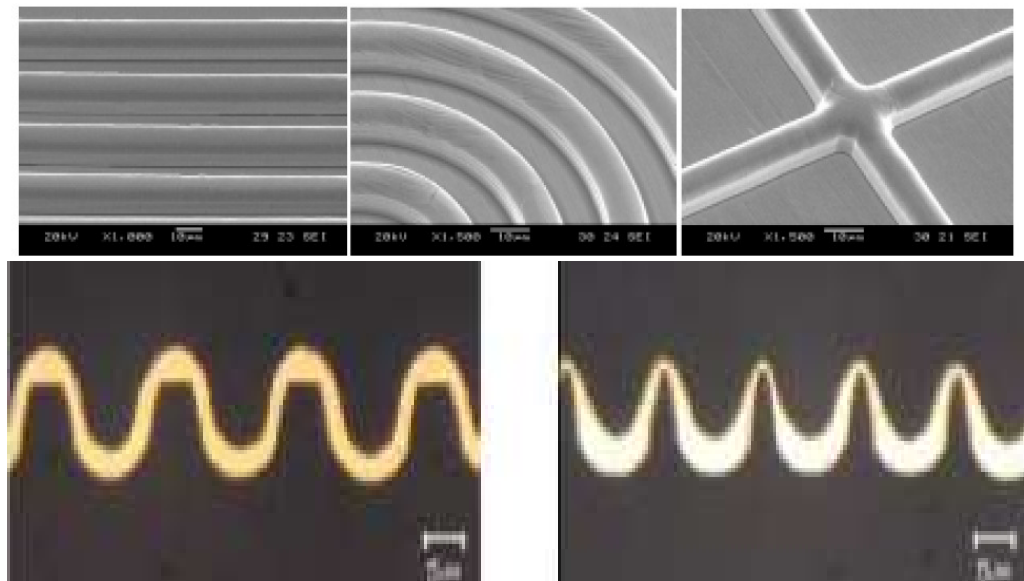

Figure 20: Hydroformed Micro-Channels on Ultra-Thin Copper foil

The outcomes of the experiments indicated that the copper sheet exhibited the capability to be entirely shaped into a concentric channel configuration. In contrast, the stainless-steel sheet exhibited limitations in being fully formed into any channel shapes. Moreover, an investigation into the impact of the inter-channel distance disclosed its influence on the distribution of wall thickness within the copper foil. Notably, results highlighted a pronounced thinning effect, reaching up to approximately 75%, in instances where a narrower inter-channel distance of 1 μm was employed, as compared to cases with wider channel spacing.

Several metal forming processes have been scaled down and investigated to understand the effects of miniaturization. Among these processes, bulk microforming techniques such as micro part extrusion and micro wire drawing have been explored by researchers including Cao et al. (2004), Rosochowski et al. (2007), and Yasunori Saotome et al. (2001). Cao et al. (2004) conducted a micro-scale extrusion experiment involving the extrusion of micro pins with diameters of 1.2 and 4.8 mm. Their study highlighted the observation that smaller grain size in the billet led to a higher ram force requirement, indicating an increase in flow stress with decreasing grain size. The development of a standard model machine (Figure 21) for micro extrusion was achieved by Guana University, Japan [Yasunori Saotome 2000], as well as Northwestern University, USA. These machines have significantly contributed to the advancement of micro extrusion processes. Notably, the output of these processes is exemplified by the micro parts showcased in Figure 24 [Engel et al, 2002, Vollersten et al., 2004].

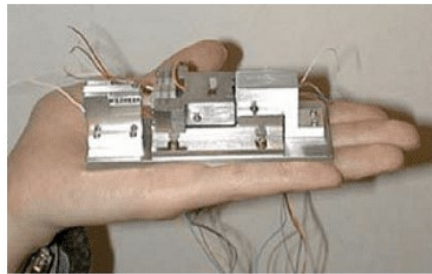

Figure 23: Micro Extrusion Machine.



Figure 24: Typical Examples of Micro Parts.

Micro deep drawing and other sheet metal forming processes like punching and bending have also been studied. As the present research work deals with forming of miniaturized sheet metal parts, further discussion is focused on micro sheet metal forming processes.

5. Micro Deep Drawing: Conventional deep drawing stands as a pivotal cold-working sheet metal forming process, instrumental in transforming a flat sheet into a cup-shaped or box-shaped component with notable speed. This process involves the use of a punch to press the blank into the die cavity, as illustrated in Figure 25. The term "deep drawing" denotes that the depth of the resultant cup exceeds half its diameter. To curtail the occurrence of sheet wrinkling during the drawing into the die cavity, sufficient blank holding force is imperative [Dieter, 1998]. The application of the deep drawing process is widespread and encompasses the production of cup-shaped parts featuring considerable depth, housings, and intricate components.

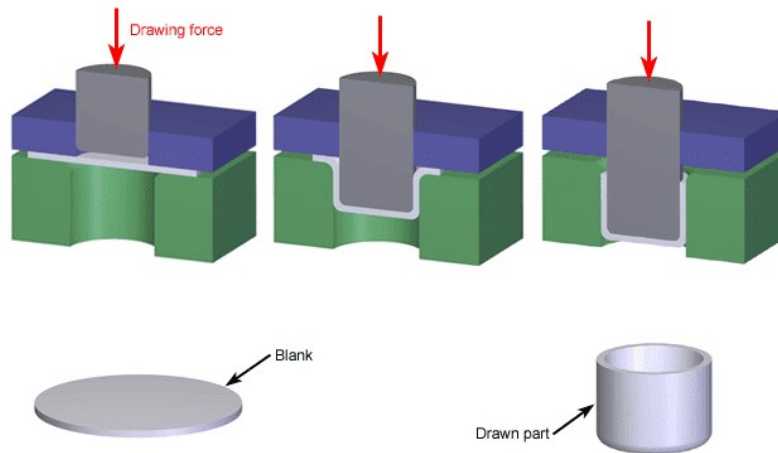

Figure 25: Deep Drawing

The micro deep drawing process entails the miniaturization of the conventional deep drawing process. This approach has spurred investigations into the consequences of miniaturization in deep drawing. Saotome et al. (2001) delved into the realm of micro deep drawing involving exceedingly thin sheets with thicknesses below 0.2 mm. They emphasized the significance of the punch diameter to thickness ratio (D_p/t), a parameter ranging from 10 to 100. Notably, their findings revealed that an elevation in the D_p/t ratio led to a reduction in the limiting drawing ratio (LDR). For D_p/t ratios exceeding 40, an observable trend emerged where increased D_p/t values prompted higher demands for blank holder pressure. Furthermore, the influence of die radius on drawability was noted for D_p/t ratios below 15, demonstrating that a decrease in die radius to thickness ratio necessitated augmented blank holder pressure.

Furthermore, a micro-hole punching machine was developed by Byung et al. (2005) to meet the exacting process accuracy requirements for 25 μm -sized holes. Each of these investigations yielded insights into the scale effect brought about by miniaturization.

IV. MACHINES FOR MICRO FORMING

Challenges associated with miniaturization extend to the realm of machinery and equipment. As components become smaller, the need for appropriately sized machines or presses becomes paramount in facilitating micro forming operations. The inherent small size of formed components necessitates correspondingly diminutive forming equipment and tooling. The micro metal forming manufacturing system represents a quintessential ultra-precision forming press capable of producing an array of micro-scale products from thin metal foils. This precision apparatus encompasses sizes ranging from several microns to millimeters, offering a precision level spanning from sub-microns to micrometers. The micro press system embodies a precision forming solution characterized by a desktop-sized platform, capable of executing diverse processes including micro-extrusion, micro-hole punching, micro deep drawing, and micro bending. A comparative analysis of the distinctive features of conventional and micro presses is detailed in the table [reference to the table 1.

Table 1: Characteristic Comparison of Conventional and Micro Press Process

	Conventional Press	Micro Press
Equipment size	Meter scale	cm scale
Forming component size	cm – m	μm - mm
Forming component precision	μm scale	nm - μm
Productivity	High	High
Shape	3D	3D
Material type	Metal, polymer, Glass etc.	Metal, polymer, Glass etc.
Capacity	1-1000 MN	Up to 5000 N
Type of drive system	Hydraulic, Mechanical, Pneumatic	Linear motor, piezo-electric, servo

Researchers at several institutes developed micro forming press systems for different kinds of sheet metal forming applications. The most important features of these micro forming presses are summarized in Table 2. A standard micro press accompanied by a data acquisition system is depicted in Figure 26.

Table 2: Developed Micro Forming Presses Summery.

Developed at	Dimensions	Specification	Precision	Drive Mechanism	Process/ Operation
Korea institute of industrial technology (KITECH), Korea [Hye-Jin Lee et.al 2008]	260*340*655 mm	5000N load capacity, Max. speed 400mm/min	resolution of 0.1 μ m	servo motor	Punching of foil
Habin institute of technology, China [Chunju et.al., 2006]	200*200*350 mm	NA	Displacement 0.1 mm	piezoelectric	Coining of micro gears
Warsaw university of technology, Poland [W prez et al.,2006]	NA	NA	NA	piezoelectric	Pressing followed by backward extrusion
Centre for micro technology, University of Strathclyde,UK. [Qin y et.al 2007, Y Qin et.al 2008, UPM Ltd.]	600*600*600 mm	1000 strokes per minute, 5.3KN maximum force.	Accuracy 5 μ m, resolution 0.1N for load and 0.1 μ m displacement	Direct drive linear motor (28 Kw)	Punching, blanking and bending.
Technical University,Darmstadt, Germany [P Gorch]		20KN maximum force. 1200 SPM		Linear motor	



Assembly of Tools and Trying out

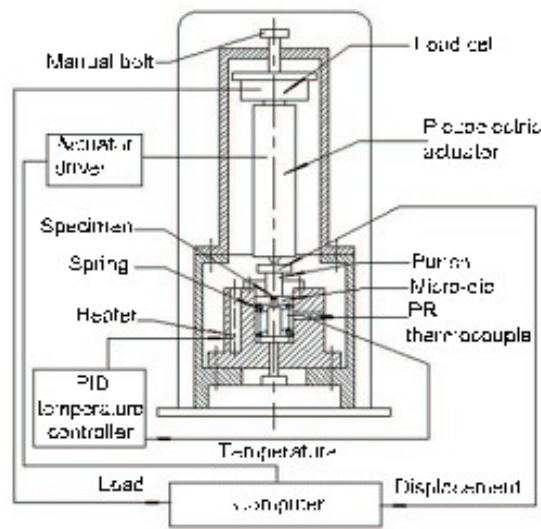

1 Schematic diagram of the microforming apparatus

Punching for producing of gears

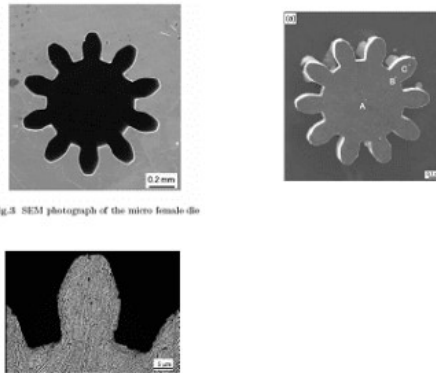

Fig.3 SEM photograph of the micro female die

Figure 26: Micro Forming Press and Micro Gear.

Micro-manufacturing necessitates the utilization of micro-handling systems, a practice that involves the precise manipulation of small components. Notably, clearances between machine parts, which might be negligible for conventional forming processes, can substantially impede the accuracy of the final products in micro-manufacturing scenarios [Geiger, 2001]. It's worth noting that due to the minute gripping surfaces and the low part weight relative to adhesion forces, micro parts don't readily separate from grippers autonomously, thus necessitating tailored solutions for effective handling and manipulation. [Sanchez-Salmeron et al., 2005].

V. TOOLS FOR MICRO FORMING

As previously highlighted, researchers have adopted miniaturized tools featuring diameters spanning from 50 μm to 10 mm for applications in micro sheet metal forming. However, the fabrication of such tools to attain the requisite precision through conventional manufacturing processes poses significant challenges.

In response to these challenges, innovative manufacturing methods have emerged to surmount the obstacles. Engel et al. (2002) and Hanada et al. (2003) provided a comprehensive survey of techniques employed for the fabrication of micro-dies. One notable method discussed is electric discharge machining (EDM), where tungsten wire as fine as 30 μm is employed to cut steel and WC with a remarkable tolerance of 2 μm . Another notable technique employed to manufacture highly accurate tooling is grinding, yielding impressive outcomes such as a 60 μm diameter punch with a precision of 1.5 μm and a micro extrusion die cavity of 0.2 mm. [Geiger et al.,1996].

VI. SUMMARY

The literature survey provided earlier underscores the significance of micro forming processes and the extensive endeavors directed towards advancing equipment, specifically machines and micro presses, for micro forming applications. The examination also encompasses a comprehensive exploration of various facets of micro forming processes. This review aptly elucidates the difficulties encountered in manufacturing micro parts through this technique, considering factors like material flow behavior, the paramount need for high precision, and the intricate nature of designing and constructing micro presses and tooling.

These challenges collectively create a promising avenue for ongoing and future research within the realm of micro forming technology. The potential for further investigations in this field is evident, as addressing these challenges necessitates the development of novel methodologies and strategies, thereby opening up new avenues for exploration and advancement.

REFERENCES

- [1] B. Eichenhüller, U. Engel and S. Geißdörfer,2008, “Process parameter interaction in microforming”, *International Journal Material Forming*,1,451- 454.
- [2] Bourella, 2006, work shop on micro manufacturing
- [3] Brad Kinsey and Richard Onyanacha,2007, “Microforming: Fundamental Studies and Path Forward”, *Micromanufacturing 2007 Conference*, March 14-15, 2007, Hoffman Estates, Illinois.
- [4] BYUNG, -. Y. J., RHIM, S.-H. & OH, S.-L. ,2005, “Micro-hole fabrication by mechanical punching process”. *Journal of Materials Processing Technology*, 170, 593.
- [5] Chunju Wang, Debin Shan, Bin Guo,Jian Zhou and Lining,2007, “ Key Problems in Microforming Processes of Microparts” *Journal of Material Science Technology*, Vol.23 No.2, 283-287.
- [6] Dieter,G.E, 1988, “Mechanical metallurgy”. McGraw-hill book publication, SI metric edition,
- [7] Engel, U. and Eckstein, R.,2002, “Micro forming – from basic research to its realization”, *J. Mater. Proc. Technol.*, 125/126 (2002), 35-44.
- [8] F. Vollertsen, H. Schulze Niehoff, Z. Hu, 2006, “State of the art in micro forming”, *International Journal of Machine Tools & Manufacture*, 46,1172–1179.
- [9] F. Vollertsen, *Laserstrahlumformen – Lasergestutzte Formgebung: Verfahren Mechanism, Modellierung*. Meisenbach Verlag,1996.
- [10] Geiger, M., Kleiner, M., Eckstein, R., Fiesler, N.,Engel, U., 2001, “ Micro forming”, *CIRP Keynote paper, Annals of the CIRP*, 50/2: 445-462
- [11] Ghobrial, M. I., J. Y. Lee, et al. (1993). "Factors Affecting the Double Cup Extrusion Test for Evaluation of Friction in Cold and Warm Forging." *CIRP Annals - Manufacturing Technology* 42(1): 347-351.
- [12] Groche P, Schneider R,2004, “Method for the optimization of forming presses for the manufacturing of micro parts”. *Ann CIRP* 53:281–284. doi:10.1016/S0007-8506(07)60698-2
- [13] H. Justinger, G. Hirt,2009, “Estimation of grain size and grain orientation influence in micro forming processes by Taylor factor considerations”, *Journal of materials processing technology* ,209, 2111–2121.
- [14] Hye-Jin Lee, Nak-Kyu Lee, Geun-An Lee, Hyoung-Wook Lee, Seogou Choi,Eun-Duk Chu, Taejoo Kim and Junhee Shin,2008, “Research on the Modulating of the Desktop Micro Forming System to Micro

- Factory”, International Conference on Smart Manufacturing Application, April. 9-11, 2008 in KINTEX, Gyeonggi-do, Korea, 196-199.
- [15] Kals T A, R. Eckstein, 2000, “Miniaturization in sheet metal working”, *Journal of Materials Processing Technology*, 103 (2000), p. 95-101
- [16] K. Manabea, T. Shimizua, H. Koyamab, M. Yanga, K. Itoc, 2008, “Validation of FE simulation based on surface roughness model in micro-deep drawing”, *Journal of materials processing technology*, 204, 89–93.
- [17] Keeler, S.P., 1971 “Understanding sheet metal formability”, *Sheet metal industry* 357-364
- [18] Mahabunphachai, S. and M. Koç (2008). "Investigation of size effects on material behavior of thin sheet metals using hydraulic bulge testing at micro/meso-scales." *International Journal of Machine Tools and Manufacture*, **48**(9) p 1014-1029.
- [19] M. Geiger, R. Eckstein, U. Engel, 2001, “Study of micro sheet metal working processes”, *Production Engineering*, Vol. VIII/1 (2001), p. 55-
- [20] M. Geiger, F. Vollertsen, R. Kals – “Fundamentals on the manufacturing of sheet metal microparts”, *Annals of the CIRP*, Vol. 45/1 (1996), p. 277-282
- [21] M. Geiger, A. Messner, U. Engel – “Production of microparts – size effects in bulk metal forming, similarity theory”, *Production Engineering*, Vol. IV/1 (1997), p. 55-58
- [22] Michel, J. F. and P. Picart (2003). "Size effects on the constitutive behaviour for brass in sheet metal forming." *Journal of Materials Processing Technology* **141**(3)p 439-446.
- [23] Yi Qin & Colin Harrison & Andrew Brockett & Yanling Ma, 2009, “Finite-element and experimental analysis of dynamic behaviours of a micro-stamping tool system” *International Journal Advance Manufacturing Technology*”
- [24] P. Groche (2), R. Schneider, “Method for the Optimization of Forming Presses for the Manufacturing of Micro Parts”, Institute for Production Engineering and Forming Machines, Technische Universität Darmstadt, Darmstadt, Germany.
- [25] Qin, Y., Harrison, C.R., Ma, Y., Brockett, A. Juster, N., Uriarte, L. Cuevas, A. and Eguia, J. ,2007, “Process and machine system development for the forming of miniature/micro sheet metal products”, In: 7th Euspen International Conference, May 2007, Bremen, Germany.
- [26] QIN. Y., 2006, “MicroForming - Machine and tool development needs and perspectives”, *Journal of Materials Processing Technology*, 177, 8-18.
- [27] Ravi Kumar, D., 2002, “Formability Analysis of Extra Deep Drawing Steel”, *Journal of Material Processing Technology*, 130-131, 31-41.
- [28] Rosochowski A., PRESZ, W., OLEJNIK, L. & RICHERT, M., 2007, “Micro-extrusion of ultra-fine-grained aluminium”. *International Journal of Advance Manufacturing Technology*, 33, 137-146.
- [29] Raulea, L.E. Govaert, F.P.T. Baaijens, 1999, “Grain a specimen size effects in processing metal sheets”, *Advanced Technology of Plasticity*, Vol. II, Proceedings of the 6th ICTP, September 19-24, Forming of Microparts II, 939-944
- [30] Raulea, A.M. Goijaerts, L.E. Govaert, F.P.T. Baaijens ,2001, “Size effects in the processing of thin metal sheets”, *Journal of Materials Processing Technology*, 115, 44-48
- [31] Sawyer, M.J. Kaufman, J.C. Ziegert, J. Bardt ,2004, “Precision molding of metallic micro-components”, Service and Manufacturing Grantees and Research Conference/SMU – Dallas, Texas, NSF Design
- [32] S. Tanaka, T. Nakamura, K. Hayakawa, Miniature incremental forming of millimetre-sized thin shell structures, Proceedings of the 7th ICTP, vol. 1, October 28–31, 2002, pp. 403–408.
- [33] S.W. Baek, S.I. Oh, S.H. Rhiml , 2006, “Lubrication for Micro Forming of Ultra-Thin Metal Foil” , *CIRP Annals - Manufacturing Technology*, Volume 55, Issue 1, 295-298.
- [34] Sachdeva, A.K., 1990, “Development of an Aluminum Sheet Alloy with Improved Formability”, *Metall. Trans. A*, 21, 165-175.
- [35] Schuler, 1998, “Metal Forming Handbook”, Springer, New York.
- [36] Sing, W. M., Rao, K. P., 1993 “Prediction of sheet-metal formability using tensile-test results”, *Journal of Materials Processing Technology*, 37, 37-51,
- [37] Sobis, T., U. Engel, et al. (1992). "A theoretical study on wear simulation in metal forming processes." *Journal of Materials Processing Technology* **34**(1-4): 233-240.
- [38] Swaminathan, K., Padmanabhan K.A., 1991, “Some Investigation on the Forming Behaviour of an Indigenous Extra-deep Drawing Low Carbon Steel- Part-1: Experimental Results”, *Trans. Indian Inst. Met.*, 44, 231-247.
- [39] Vollertsen, F., Hu, Z., Niehoff, H., and Theiler, C., 2004, “State of the Art in Micro Forming and Investigations into Micro Deep Drawing” *Journal of Materials Processing Technology*, 151, 70-79.

- [40] W. Presz, B. Andersen, and T. Wanheim, 2007, "Piezoelectric driven Micro-press for microforming", *Journal of Achievements in Materials and Manufacturing Engineering*, Volume 18, issue 1-2, 411-414
- [41] Wang, Z., Wang X., 2001, "A New Technology to Improve the \bar{r} -Value of Interstitial-Free (IF) Steel Sheet", *Journal of Materials Processing Technology*, 113, 659-661.
- [42] Y. Qin, Y. and Ma, Y. and Harrison, C.R. and Brockett, A. and Zhou, M. and Zhao, J., 2008, "Development of a new machine system for the forming of micro-sheet-products". In: 11th ESAFORM 2008 Conference on Material Forming, 23-25 April 2008, Lyon, France.
- [43] Y. Saotome, H. Iwazaki, 2000, "Superplastic extrusion of microgear shaft of 10 μm in module", *Microsystem Technologies*, 6, 126-129
- [44] Y. Saotome, H. Iwazaki, 2001, "Superplastic backward microextrusion of microparts for micro-electro-mechanical systems", *Journal of Materials Processing Technology*, 119, 307-311.
- [45] Y. Saotome, K. Yasuda, H. Kaga, 2001, "Microdeep drawability of very thin sheet steels", *Journal of Materials Processing Technology*, 113, 641-647
- [46] Y. Saotome, T. Okamoto, 2001, "An in-situ incremental microforming system for three-dimensional shell structures of foil materials", *Journal of Materials Processing Technology*, 113, 636-640
- [47] Y. Saotome, Y. Noguchi, T. Zhang, A. Inoue, 2004, "Characteristic behavior of Pt-based metallic glass under rapid heating and its application to micro forming", *Materials Science and Engineering A*, 375-377 (2004), 389-39
- [48] Chunju WANG y, D. S., Bin GUO, Jian ZHOU and Lining SUN (2007). "Key Problems in Microforming Processes of Microparts." *Journal of Material Science Technology* 23(2): 283-288.
- [49] Debin, S., X. Jie, et al. (2009). "Hybrid forging processes of micro-double gear using micro-forming technology." *The International Journal of Advanced Manufacturing Technology* 44(3): 238-243.
- [50] Geiger, M. Kleiner, et al. (2001). "Microforming." *CIRP Annals - Manufacturing Technology* 50(2): 445-462.
- [51] Ghobrial, M. I., J. Y. Lee, et al. (1993). "Factors Affecting the Double Cup Extrusion Test for Evaluation of Friction in Cold and Warm Forging." *CIRP Annals - Manufacturing Technology* 42(1): 347-351.
- [52] Joo, B. Y., S. I. Oh, et al. (2004). "Forming of Micro Channels with Ultra Thin Metal Foils." *CIRP Annals - Manufacturing Technology* 53(1): 243-246.
- [53] Mahabunphachai, S. and M. Koç (2008). "Investigation of size effects on material behavior of thin sheet metals using hydraulic bulge testing at micro/meso-scales." *International Journal of Machine Tools and Manufacture* 48(9): 1014-1029.
- [54] Messner, A., U. Engel, et al. (1994). "Size effect in the FE-simulation of micro-forming processes." *Journal of Materials Processing Technology* 45(1-4): 371-376.
- [55] Michel, J. F. and P. Picart (2003). "Size effects on the constitutive behaviour for brass in sheet metal forming." *Journal of Materials Processing Technology* 141(3): 439-446.
- [56] Olejnik, L., W. Presz, et al. (2009). "Backward extrusion using micro-blanked aluminium sheet." *International Journal of Material Forming* 2(0): 617-620.
- [57] Sobis, T., U. Engel, et al. (1992). "A theoretical study on wear simulation in metal forming processes." *Journal of Materials Processing Technology* 34(1-4): 233-240.
- [58] Vollertsen, F., Z. Hu, et al. (2004). "State of the art in micro forming and investigations into micro deep drawing." *Journal of Materials Processing Technology* 151(1-3): 70-79.