

AN INSIGHT OF METAL OXIDE-BASED PHOSPHORMATERIALS AND THEIR APPLICATIONS

Abstract

Phosphor is a general term used for mainly such inorganic materials which have capability to exhibit luminescent properties by emitting the absorbed light in visible region mostly. When a radiation either present in electromagnetic spectrum or a beam of electrons as well as photons is imparted on the powdered surface of phosphors material, there is emission of light mainly in visible region, which further corresponds to various characteristic colours exhibiting phosphors. We can also assume phosphors materials to be working on the principle of same as that of transducer because of the phenomenon of conversion of one form of energy into another while emanating the light in mainly visible region.

On the basis of usage of different source radiation for the excitation of phosphors materials, they can be classified into various categories such as photoluminescence, cathodoluminescence, electroluminescence, triboluminescence, X-ray luminescence, and chemo luminescence. In recent decades, there have been immense research on the metal oxide doped phosphors due to significant increased stability and comparatively very smooth synthetization process having great practical applicability in various fields. Further the principle of luminescence, which is, mainly based on excitation of valence electrons present in d and f orbitals of valence shell of metal oxide doped phosphors, will be discussed in details in this chapter. There are various characterization techniques that are used for the investigation and analysis of metal-

Authors

Supriya Sehrawat

Department of Physics
Deen Bandhu Chhotu Ram University of
Science and Technology
Murthal, Haryana, India.

Surender Duhan

Department of Physics
Deen Bandhu Chhotu Ram University of
Science and Technology
Murthal, Haryana, India.
E-mail: surender6561@gmail.com

Priya

Department of Physics
Deen Bandhu Chhotu Ram University of
Science and Technology
Murthal, Haryana, India.

oxide based phosphors such as Thermogravimetric/Differential Thermal Analysis (TG/DTA), Fourier Transform Infra-red (FTIR), X-Ray Diffraction (XRD), Scanning Electron Microscopy (SEM), Transmission Electron Microscopy, Photoluminescence spectroscopy along with Phonon Side Band Analysis, and Colorimetry, UV-Vis-NIR spectroscopy, Raman spectroscopy, X-ray Photoelectron spectroscopy and z-scan technique, are briefly discussed in the chapter. Finally, this chapter accounts briefly the various practical applications of metal oxide-based phosphors as light emitting diodes, LEDs, fluorescent lamps, cathode ray tubes, safety indicators, plasma displays etc.

Keywords: Luminescence; Phosphors; Characterization, Applications

I. INTRODUCTION OF PHOSPHOR MATERIAL

The word phosphor also means luminescent material, i.e., a material which can convert the captured energy to visible energy, without undergoing incandescence. A luminescent material i.e., phosphor materials are basically a type of transducer because they emit light by conversion of one type of energy to other type [1]. They are mainly be made of crystals or non-crystals. They are made of host lattice and one or more guest which are also known as activators, with different concentration mole percent. Guest and host lattice compliments each other for the luminescence characteristics of a phosphor. Phosphors are usually in the size range from micrometre to nanometre.

Over the few decades, light emitting technology has evolved very rapidly and is a growing research field. As the size of particle changes, the emitted colors by them also vary. The nano sized phosphors have characteristic features, like the band gap is enlarged with reduction of particle size and superior quantum efficiency for luminescence.

Depending on the methods of excitation, luminescence have following categories: photoluminescence (excited by electromagnetic radiations, e.g. in fluorescent lamps), cathodeoluminescence (by electron beams, e.g., in cathode ray tubes), electroluminescence (by electric field, e.g., in television screens, computer monitors etc.), triboluminescence (by mechanical energies, e.g., grinding), X-ray luminescence (by X-rays), and chemo luminescence (by chemical energies). Light release from any phosphorous matter is classified to as either fluorescence or phosphorescence [2]. Emitting of light when a matter is excited by incident radiation is known as fluorescence and phosphorescence is the kind of luminescence observed after the light source have been removed.

II. CLASSIFICATION OF LUMINESCENCE

From the perspective of the excitation energy and on the basis of usage of different source radiation for the excitation of phosphors materials, luminescence can be classified into different categories.

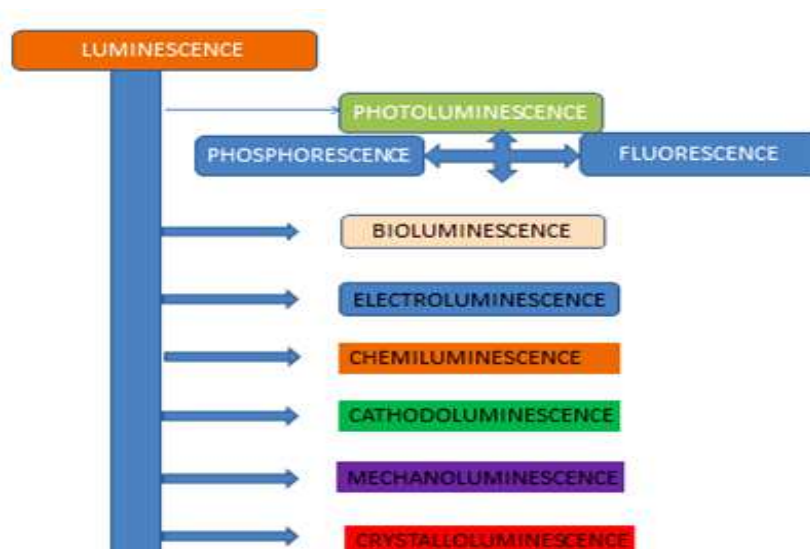

Figure.1: Categories of phosphors material

- 1. Photoluminescence:** Emission of light generated by moving electron due to the influence of em radiation to energetically excited levels by the absorbing photons that may occur by phosphorescence or fluorescence[3].

On the basis of emission, we can classify photoluminescence as:

- **Fluorescence:** Fluorescence is a process in which there is emission of light by any particle by absorption of light / other em radiation. There are tons of applications of fluorescence such as, as chemicals sensors, fluorescent dyes, biological detectors and fluorescent lamps.
 - **Phosphorescence:** In mechanism of phosphorescence there is emission of light continuously even though the source of excitation has been withdrawn.
- 2. Electroluminescence:** It is a kind of optoelectronic process wherein light is produced by the matter by passage of electric current. It is a due to the radiative recombination of electrons & holes in the substance, generally a semi-conductor[4].
 - 3. Mechanoluminescence:** Due to the mechanical action on a substance the mechanoluminescence is produced which can be further classified into following ways.
 - **Triboluminescence:** Emission of light due by a solid because of mechanical actions like colliding, scraping, crashing or grinding, the phenomenon is called as triboluminescence.
 - **Crystalloluminescence:** Luminescence infrequently generated in process of crystallization. It is also a kind of chemiluminescence as the energy is generated basically from the inter atomic bonding.
 - **Fractoluminescence:** Rupturing of bonds of crystal results in emission of light, known as fractoluminescence.
 - **Piezo luminescence:** Emitting of light by a solid when pressure is exerted on it.
 - 4. Chemiluminescence:** chemiluminescence is the process of generation of em in form of light using the energy that is released from chemical reactions.
 - 5. Bioluminescence:** Living organisms also produce luminescence. These molecules that are generating light are excited through a chemical reaction so, bioluminescence is related with chemical luminescence. There are organisms like fireflies that produce luciferin and luciferase chemicals. Luciferin pigment generates light by the reacting with oxygen whereas luciferase acts as a catalyst to fasten the process.
 - 6. Radio luminescence:** Materials when subjected to ionizing radiations (α , β or γ rays) there is production of luminescence.. The emission of light by a substance resulting from the pounding with these ionizing radiation is known as radio-luminescence. Pierre and Marie Curie were first to report radio luminescence.
 - 7. Thermoluminescence:** Emission of light by any mineral when subjected to heat is thermoluminescence. Thermoluminescence is a useful tool for finding the age of archeological artifacts.

- 8. Cathodoluminescence:** light generation due to action of incident electron beam on a luminescent matter, for example “phosphor”[5]. From a long time cathodoluminescence has been used for constructing displays like flat screen displays like LCD’s, classical cathode ray tube.

III. PHOSPHOR SYNTHESIS TECHNIQUES AND METHODS

Oxide phosphors synthesis can be done by various routes such as sol-gel techniques, hydrothermal precipitation, solid state reactions and solution combustion synthesis [6,7]. The refractory nature of oxide precursors allows the solid reactions to be done at elevated temperatures, like 1500°C.

In multi elemental composition incomplete reaction take place which results in unwanted precursor in resulting product. In this method we need to include some heating and grinding steps to get small sized phosphors. In hydroxide or sol gel methods, dilute solution of metal salts were reacted, condensed to give an amorphous crystalline matter. The upper hand of listed methods is that we get the mixed powder (atomically) and incomplete reaction is ignored. The particles synthesized are heated so that it crystallizes into the required phase and to have grain size more than 0.3 μm. Hydrothermal technique gives us well crystallized powders as it is a high pressure and low temperature technique. The obtained powders should be subjected to elevated temperature to get the superior luminous efficiency. From past few years we are relying on combustion synthesis for phosphor synthesis. Various synthesis techniques are applied for synthesis of rare-earth doped oxide -nanophosphors. An explained description of synthesis procedures is given below.

- 1. Solution combustion synthesis technique:** Solution combustion is a stimulating process, in which exothermic reaction takes place without any assistance in any aqueous media propagates. This process permits the synthesis of various nanomaterials which includes alloys, sulphides, oxides and metals. In solution combustion method, beginning materials are usually in the form of nitrates and citric acid/urea act as an organic fuel[8]. The beginning material and urea is then dissolved in purified water and clear solution is obtained. By heating on magnetic stirrer, extra water is removed and quick ignition happens. At first solution dehydrates resulting in release of gaseous products. When spontaneous combustion happens the solution burns and releases heat. The solution liberates CO₂ and NO₂ gas products and forms like a burning solid as the combustion completes. When the cooling is completed, the fluffed mass crushed with the help of a mortar and pestle till dry, thin powder is achieved. The obtained powdered phosphors are occasionally annealed at various temperature for the sake of good crystallinity.

2. Wet Chemical method:

It can be grouped in 3 types: -

- Gelation route
- Sol gel route
- Polymerizable complex route

The mixing of reactants by hydrolysis and condensation, then heating at elevated temperature begins the reaction. Mass production can be obtained by sol gel

synthesis and the synthesized products also offers high luminescence intensity because of high crystallinity obtained by annealing at high temperature. The nanocrystals obtained from sol gel synthesis have large sized particle distribution and irregular morphology of particles & insolubility against water is obtained and this shows the demerits of this method.

- 3. Hydrothermal method:** To produce nanoparticle, a chemical method is used that can react between positive and negative charge ions that separate out from solvent under elevated temperature and pressure hydrothermal technique is used. The hydrothermal synthesis of Y_2O_3 nanoparticles given as:-

The beginning material i.e. all nitrate precursor is taken 1mmol and added to 30 ml of ultrapure water and then adding NH_4OH for pH value to reach at 14. The resulting mixture is put into a 60 mL of stainless Teflon lined autoclave and permitted to react at $130^\circ C$ for 13 h. Now it is allowed to cool down at normal temp. The product is now washed with ultrapure water to wash out remaining organic compounds then centrifuged to obtain nanoparticles. Now the obtained nanoparticles in powder form is dried in oven[9].

- 4. Thermal decomposition method:** A traditional technique used to prepare inorganic nanocrystals made by disintegration of organic precursors in organic solvent at elevated boiling point. The synthesis of $NaREF_4$ ($RE \frac{1}{4} Pr$ to Lu, Y) Nanoparticles by $Na(CF_3COO)$ and $RE(CF_3COO)_3$ as precursors. 1-octadecene with elevated boiling point act as the non-coordinating solvent to give a elevated temperature atmosphere. Oleic acid and oleyl amine with good coordinate capabilities used as the coordinating solvent, which supports in capping the surface of the nanoparticles to stop cluster formation. This results in good quality of oxide phosphor materials.

IV. CHARACTERISATION TECHNIQUES USED FOR PHOSPHOR MATERIALS

Phosphors are characterized by investigating its luminescence properties, particle size, colour coordinate values and morphology. Particle size and morphology were demonstrated by X ray diffraction (XRD) studies. Scanning e- microscopy (SEM) and tunnelling e- microscopy techniques are also beneficial for finding size and morphology of the particles of phosphors.

The synthesized phosphors can be characterized by following available techniques.

- Fourier Transform Infrared (FT-IR) analysis.
- Luminescence spectroscopy.
- Determining the color coordinates (Tristimulus calorimetrys)
- X ray diffraction(XRD) studies.
- Scanning e- microscopy(SEM).
- Transmission e- microscopy(TEM).

- 1. Fourier Transform Infrared Spectroscopy:** Infrared spectroscopy is used for analysing the vibrational motions of molecules. In short it is described that, the diverse movements between various atomic groups make the molecule to absorb dissimilar quantities of energy. The study of these transitions provide information for the types of atoms that are

bonded or grouped in an unidentified compound, which in result gives indication concerning the molecular structure. In FTIR spectroscopy, IR radiation In FTIR spectroscopy, IR radiation go through a compound. A few of these radiations are absorbed by the compound and few of these are transmitted in atmosphere. The spectrum results in the molecular fingerprint by corresponding to molecular absorption and its emission.

Two distinctive molecular structures generate different infrared spectrum. This is the cause of importance of infrared spectroscopy for a lot of kinds of analysis. Also, IR gives a very faster method of recognizing chemicals structures. In instrumentation of IR spectroscopy, EM radiation with frequency between 4000 and 400 cm^{-1} (wavenumbers) is apprehended with spectroscopy. Absorption of energy in this region occurs from alterations in the vibrational energy of the molecules. Absorption in this region which gives large amount of information about finding the structure and verify the compounds due to the fact that these radiations are soak up by bonds within the atoms of compounds. Chemical bonds in variable environments will soak different intensities and frequencies. Consequently, Infrared spectroscopy includes all details of absorption and analysis of spectrum. The absorptions frequencies of Infrared radiation (—peaks|| or —signals||) can be contrast direct to bonds within the compound. Each interatomic bond can vibrate.

- 2. Instrumentation:** The FTIR spectra of different samples were obtained by the use of a Nicolet 5700 infrared spectrometer at temperature of 25degrees in the wavelength region of 4000-400 cm^{-1} The radiations produced by source of radiation, a small ceramic rod, consisted of silicon carbide or Nernst filament are parted into two beams, one of which passes through the sample and other functions as reference beam. The reference and sample beams are then transferred alternatively into a monochromator at small intervals with the help of rotating mirror. In the monochromator the emergent beams are filtered out into individual wavelength with the help of a single prism which is transparent to infrared radiation. The pulsating single beam coming through the exit slit is a narrow band made of only very few frequencies. After this dispersion, the beams are focused alternatively at each and every wavelength within the spectral range. The spectrum measures the difference in intensities of the reference and sample beams within wavelength range is put down on a special graph paper.
- 3. Photoluminescence (PL) Spectroscopy:** Photoluminescence (PL) is the technique by which light energy is absorbed by the material and some of it is emitted in the visible or near visible region. The excitation source can be IR, visible, UV or X-rays. Photoluminescence is basically classified into fluorescence and phosphorescence. If emission happen in microseconds or even hours after excitation is vanished, it is called Phosphorescence. Photons are absorbed when more than or equal to threshold wavelength light is incident which results in electronic transition. When excitation relax, electron reach to ground state in two possible ways i.e., radiatively/ non radiatively. If relaxation happens radiatively, the emitted light is termed PL (photoluminescence).The emitted light yield a good amount of information about photo excited material. The photoluminescence spectrum gives the transition energies, which can be used to obtain electronic energy levels. A Spectro fluorophotometer is an instrument used to record the photoluminescence spectra of the materials. Excitation and emission are the two types of photoluminescence spectra. In excitation spectrum, the wavelength of the exciting light is changed in

intervals and the intensity of emitted light at a fixed emission wavelength is obtained with respect to excitation wavelength. The position of excited states determined by excitation spectrum only. The spectral distribution is given by emission spectrum. For emission spectrum, the sample is excited and emission intensity is measured w.r.t wavelength. Phonon side band analysis can be done from the excitation spectrum while the colorimetric studies is performed using the emission spectrum.

- 4. X ray Photoelectron Spectroscopy:** More commonly named as e- spectroscopy used for chemical analysis is a quantitative spectroscopic tool that helps in finding the empirical formula, composition of elements, electronic state and chemical state of the constituents. X ray Photoelectron spectra are measured by illuminating a material with a beam of X-rays and computing kinetic energy at same time and no. of e^- that get away from 1-20nm of the material being studied. Ultra-high vacuum conditions are required for XPS.. In this spectroscopy we plot a graph between the number of electrons obtained on the Y axis to the binding energy of these detected electrons plotted along X axis.
- 5. UV-Vis Spectroscopy:** Quantitative and qualitative determination of molecular species for optical absorption near infrared region is done under this technique. An absorption spectrum gives information about the sample under study which includes the wavelength of electromagnetic radiation that is absorbed by the sample. If the radiation with enough frequency or energy is absorbed, then the electronic transition take place from one energy level to other within the atom.

The energy associated with the outer shells in electronic transitions is generally lying either in visible or ultraviolet regions. The excitation of valence electrons is determined by the energy absorbed in these regions. The wavelength of radiation required for the transition is given by the absorption peaks. Absorption spectra gives the position of higher energy levels and the band gap of semiconductors and be determined.

- 6. Raman Spectroscopy:** Raman spectroscopy is a method used to study low frequency modes in a system such as vibrational, rotational and others. Inelastic scattering of monochromatic light is the concept behind this spectroscopy. The energy pf laser photons increase or decrease due to the interaction with molecular vibrations, phonons or any excitation in the arrangement. The vibrational modes can be determined by change in energy. This scattering is a novel non-destructive technique for structural characterization of some kinds of materials. The active Raman modes position depend on lattice vibration of the sample. This effect is more accurate in reduced size materials. Raman scattering has been measured in studying various types of nanostructures, and interpreted in terms of anharmonic processes, which leads to a better understanding.
- 7. X Ray Diffraction (XRD):** XRD is a tool useful for recognizing the crystal structure of a compound, wherein the crystalline atom diffracts X ray beam in different directions. The 3-D picture of how dense the electrons are, can be found by finding the angles and intensities of the diffracted beams. Elsewhere it also tells that the crystalline structure to the particular thermodynamical circumstances in which a material has been produced, also consequently gives significant information. Particularly the powder diffraction technique permits the definite recognition of crystal material and the diverse phases in a compound.

The structure determination of materials demonstrates numerous distinctive complexities. Frequently the chemical composition is relatively inconsistent, needing a discrete variation in dispersion power of the dissimilar elements for recognition of crystal structure. Two or more atoms or ions can reside in the same sites of a crystal. It often directs to dissimilar degrees of short and long range ordering, which frequently involves the subsistence of very weak intensities, making X-ray crystal study on materials is o demanding on prepared materials.

We are assuming the electrons of atoms as the scattering centres which diffracts the X ray. Bragg's equation illustrates wherein direction, at a fixed value theta and d, at which there is constructive interference of spread waves.

- 8. Scanning Electron Microscopy (SEM):** Scanning Electron Microscopy (SEM), can produce magnificent physical and structural information. When an energetic electrons beam strikes the surface of the specimen, an abundance of signals is emitted from the solid specimen as a result of electron beam matter interaction. The signals coming from the interaction of electron and sample provide us details about sample's structure and orientation. Usually data is collected through a specific area of sample and 2-D image is produced which demonstrates spatial variations. In SEM, electrons which are accelerated have considerable quantity of kinetic energy, owing to electron sample interactions a variety of signals generated.

SEM SET UP

Electrons is wasted in this technique. Subsequent to the interactions of electrons with sample, the incoming electrons are delayed in the given sample. The signals contain secondary electrons which produces SEM images, backscattered electrons (BSE), diffracted backscattered electrons which are useful to establish the structure of crystal and minerals orientation direction , photons which are characteristic X-rays and are obtained for elemental study and X rays, visible light, and heat. Secondary electrons shows the morphology as well as topography of samples and backscattered electrons are used to determine the different composition in multiphase samples.

Requirements for SEM instruments

- Magnetic and electric fields free space .
- Power Supply
- Cooling system
- Vacuum System
- Vibration-free floor

SEMs at least have one detector and also can have more than one detectors. The speciality of an instrument depends on which detectors it have. The electron current density produced by the SEM represent the spatial resolution of SEM image. The example of advancement of resolution of SEM is the development of field mission gun Crewe in 1968.

- 9. Transmission Electron Microscopy (TEM):** A technique that includes high energy of electron beam produced from an electron gun which falls on the specimen which is transparent to the electrons and contains details about the inner structure of the sample.

The transmitted e^- beam goes to imaging system and the image is magnified by various EM lenses till it strikes the fluorescent screen, /photographic plate / light sensitive plate. When the image hits the phosphor image screen, light is obtained, enabling us to view the image. The image areas that are dark tells us denser or thicker areas of the matter from where less electrons were transmitted. From where more electrons were transmitted gives light area of the image. TEM permits individual crystallite imaging and description of shape and size of particles in sample.

High magnification imaging with lattice contrast finds the General Introduction of individual crystallite morphology. A bright image is obtained if the selected beam is transmitted and dark field image when selected beam is diffracted.

10. HRTEM (High Resolution Transmission Electron Microscopy): Permits the imaging of the crystallographic structure of a sample at an atomic scale. In selected area electron diffraction (SAED), a very small area is taken from the transmission image and its diffraction pattern is obtained on the screen. The region for the diffraction patterns can be as small as 1mm. The diffraction pattern is the arrangement of various spots or a series of rings that gives us the value of d in the crystals[10]. Every compound has its own d values which are different from each other, so the identity can be confirmed by HRTEM analysis.

V. APPLICATIONS OF METAL OXIDE-BASED PHOSPHORS

Because of various features, metal oxide-based phosphors are frequently used in the manufacturing of solar water heaters, solid-state lasers, white light emitting diodes (LEDs), fluorescence immunoassays, plasma display units, cathode ray tubes (CRTs)

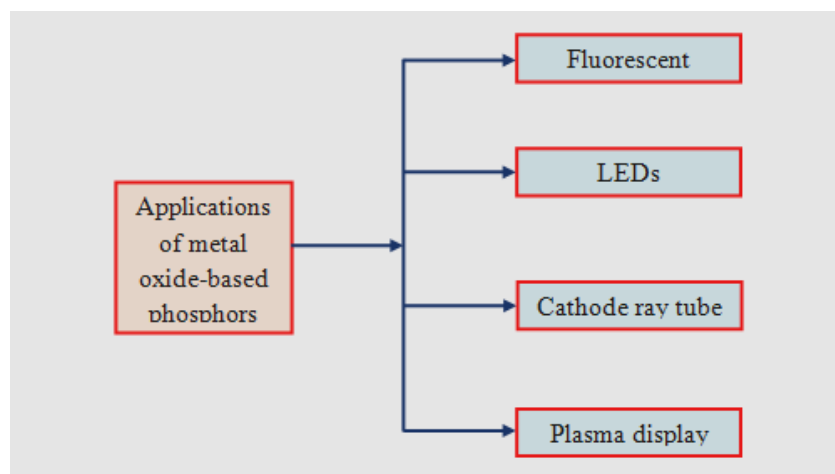

Figure 2: Applications of metal oxide-based phosphors

1. Fluorescent Lamp: The fluorescent lamp (or tube), is a low-pressure mercury-vapor gas-discharge lamp which emits visible light via fluorescence phenomenon. The electric charge in the gas drives (or excite) mercury vapor, which creates short-wave UV light and leads to the coating of phosphor to shine inside the lamp, as a result, the lamp glows. Fluorescent lamps transfer electrical energy more significantly and effectively than incandescent bulbs. The lighting sector is the largest importer of phosphor materials and

the largest producer of phosphor-related products. The phosphor coating method used in the production of such lamps has also improved. Fluorescent lamps seem to be the most prominent light sources that utilize phosphors, as we all know. Phosphors of various types are created for distinct purposes, with oxide phosphors being extensively used due to their better properties like high thermal stability and luminescence efficiency[11]. Almost all feasible phosphors used in three-band fluorescent lamps are oxides (or oxyacid salts) that can be commonly produced at 254 nm UV light by low-pressure mercury vapor discharge. Because of the excellent emission efficiency, physical and chemical durability, simple oxides mixed with aluminate phosphors are commonly employed in three-band fluorescent lamps. Yttrium oxides are generally used with Europium (Eu), Cerium (Ce) and Terbium (Tb) i.e. $Y_2O_3: Eu^{3+}$ and (Ce, Tb) $MgAl_{11}O_{19}$ phosphors emit green color, while $BaMgAl_{10}O_{17}: Eu^{2+}$ emits blue color.

- 2. Construction & working:** Regardless of the numerous varieties developed, the principles for the creation of the fluorescent lamp remains similar (Fig. 3). The lamps are primarily made of a glass tube, with a phosphor coating on the inner wall and electrodes soldered at opposite ends of the glass tube. The term "electrode" corresponds towards both negative (cathode) and positive (anode) terminals for the fluorescent lamp's electric discharge. The electrode at either end functions as the anode and cathode alternately because fluorescent lamps are typically powered by alternating current (AC) sources. The electrodes are made up of either doubly- or triply-coiled tungsten filament that has been coated with an electron enrich substance like barium (Ba)-calcium (Ca)-strontium (Sr) oxide or any metal oxides. During one AC waveform cycle, the discharged current flows from one electrode's electron-emitting tungsten wire to another, while in the next waveform cycle, the discharged current flows oppositely.

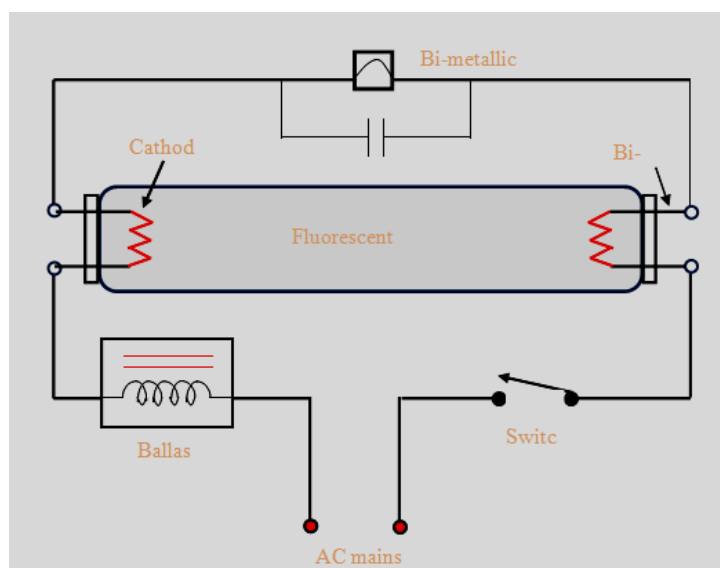

Figure 3: Construction of the fluorescent lamps.

A very small amount of mercury with a small amount of rare gas like argon, are also inserted inside the tube. After sealing the anode and cathode, the air inside tube has been removed and both mercury as well as rare gas are inserted inside the tube. The rare gas normally has a pressure between 0.2-0.7 kPa (or 1.5-5.2 Torr). The fluorescent

coating on the inside of the lamp is made up of various mixtures of rare earth and metallic phosphor salts. To enhance thermionic emission, cathode and anode of the lamp are commonly composed of coiled tungsten and coated with a combination of strontium, barium and calcium oxides. When input power is turned on, full voltage is applied to the bulb and also the starting via the ballast. But, then no discharge happens there, thus no lumen produced from the lamp. The luminous discharge in this starter is generated 1st at those higher voltages. This is because the electrode gap in a starting neon bulb of the starter is substantially lesser in comparison with the fluorescent lamp. The positive phase of the discharges forms partly ionized plasma that after arc discharges have occurred in the tube. A strong electric field is created whenever a sufficient voltage is provided across the electrodes. A homogeneous electric field of roughly 1 V/cm is created between cathode and anode in the positive column of the discharge during normal operating conditions of the fluorescent lamp, and electrons inside the plasma are pushed towards the anode direction. The kinetic energy (K.E) of the electrons gradually increases throughout this acceleration. Because the ions inside this plasma have a significantly larger mass than that of electrons, the accelerations of ions are lesser than electrons. As a result, the ions move very slowly, and hence input electric energy is primarily transferred to the K.E of electrons. The electrons interact with other particles during this acceleration, forming plasma with the creation of other types of energy.

The performance (or conversion efficiency) of the fluorescent lamp, which converts electricity into visible light, should be as much as possible. Fluorescent lighting devices have a luminous efficiency between 55–110 lumens/watt, that is many times greater than the incandescent bulbs with equivalent light intensity. The efficiency of fluorescent lamps is influenced by several factors, one of them is the phosphors utilized. Through a particular energy conversion procedure in the plasma, the input electric energy given to the lamp is primarily transformed into UV-radiation (wavelength, 185 and 254 nm). The phosphor(s) placed on the interior wall of the glass tube converts this UV light into optical radiation. Fluorescent lamps have recently reduced their size. The electron density, ions, mercury atom, and rare gas inside the plasma are all related to the dimension of these lamps. Because energy conversion processes vary based on these densities, the lamp dimensions, particularly the tube diameter, become a critical consideration while constructing the fluorescent lamps. Fluorescent bulbs are available in a variety of designs and sizes. CFLs (compact fluorescent lamps) are becoming increasingly popular. The supplementary electronics are often included in the base of CFLs, enabling such devices to fit into a standard light bulb socket.

- 3. Advantages:** Fluorescent lamps have following advantages over ordinary bulbs or incandescent lamps:
- In comparison to incandescent lights, fluorescent lamps convert more of the supplied power to visible light.
 - When used for multiple hours, a fluorescent light will often survive 10 to 20 times longer than an analogous incandescent lamp.
 - Present tube is much more diffuse and significantly larger light source in comparison with an incandescent lamp.
 - Fluorescent lamps produce around 1/5 of the heat produced by comparable incandescent lamps.

- 4. Disadvantages:** Fluorescent lamps also have some disadvantages are mentioned below:
- Frequent lamp switching (>3 hours) reduces lamp lifespan.
 - The UV light is emitted in small amounts by fluorescent lamps. In photosensitive people, UV from CFLs may intensify symptoms.
 - Approximately 10% of the lamp's input electric energy is lost in magnetic ballasts.
 - Fluorescent lamps work best when kept at room temperature. The efficacy of such lamps reduces when the temperature rises or falls. Conventional lamps may not turn on in temperatures below freezing.
- 5. Light Emitting Diodes (LEDs):** Baird and Pitman at Texas Instruments invented the first practical semiconductor-based LEDs in 1961. Because the material (InGaP) employed had a bandgap of 1.37 eV, such devices radiated in the near-infrared region. Holonyak and colleagues produced the first visible LED a year afterward, they created a device that emits red light using a new composition, i.e. GaAsP. Using more advanced technology and additional materials like AlGaAs contributed to the growth of conventional LED, which is mostly used in indicator lights, from that time forward. Hitherto, several types of LEDs were developed and a brief classification of them are described below:
- **White and Colored LEDs:** The mixture of numerous pure colors, in general, produces white light. Combining blue with yellow or orange light sources is the easiest process to create a light source having a white color[12].As one increases mixing of the number of primary colors, for example, Red-Green-Blue (RGB) LED instantaneously allows for substantially better CRI values and thus achieved a white light source having high-quality. Color stability, as well as high color rendering, are advantages of white LEDs produced using UV LEDs and red, green, and blue-emitting phosphors[13]. The phosphors, which produced white LEDs are generally based on various white light-generating sources, such as sulphides, oxides, and nitrides [14]. Colored LEDs are made of two main materials: (1) AlGaInP is used for orange, yellow and red color; (2) In GaN is used for blue & green color.
 - **Phosphor-Converted LEDs:** As previously stated, white light could be created by mixing the light of various color LEDs. Individual RGB LEDs offer excellent efficiency and flexibility, user-controlled color, but expensive circuits are required since the proportions of distinct RGB light is chosen with caution because the LED output (color & intensity) changes with current flow, device aging, and temperature. It is also challenging to achieve homogeneous optical mixing of light. Displays with a wide color range are possible due to the high saturation of the fundamental LED colors. Because normal LCD backlights are based on fluorescent lamps, resulting in a limited color range, this can be used to enhance the LCD color range [15].The color point of phosphor-converted LEDs (pcLEDs) significantly depends on phosphor layer type, packaging density and thickness. Owing to the increase in excitation density, the applied phosphor(s) must exhibit strong blue light absorption as well as good photochemical stability, for example, for 1Watt In GaN LED (30 W-cm²): chip area equals to 1 mm² and efficiency equals to 30%). In fluorescent lamps, the magnitude of aforesaid value is over three orders greater than the excitation density accomplished by phosphors, and it has numerous implications for the physical as well as properties of relevant phosphors. As a result, phosphors LED are triggered by ions with a high quantum efficiency.

The hosting substrate needs to be chemically as well as thermally stable to sustain the LED lifetime greater than 10 thousand hours. Furthermore, a faster decay time of the phosphor prevent saturation at higher driving rates, as this would shift or changes the result, for example: a blue-shift, in the LED spectrum as driving circumstances to change. LED converter substances are hence triggered by ions that rely on permitted 4f-5d transitions like Eu^{2+} and Ce^{3+} , that are doped into stiff host lattices. The white LED industry is currently led by pcLEDs, which are composed of InGaN (420 to 480 nm) covered with a Ce^{3+} -triggered phosphor generated from the mineral grossular ($\text{Ca}_3\text{Al}_2\text{Si}_3\text{O}_{12}$) crystallizing in the garnet configuration. The Ca_2 is replaced by Y_3 and Si_4 by Al_3 to form $\text{Y}_3\text{Al}_5\text{O}_{12}$, which is simply doped by Ce^{3+} and other trivalent rare-earth ions like Gd^{3+} or Tb^{3+} . The most often used phosphor is (Y, Gd) $3\text{Al}_5\text{O}_{12}:\text{Ce}$ (YAG:Ce), in which the effective color temperature of the light output by a pcLED is determined by the optical thickness of the phosphor layer. As the layer thickness increases, the colour transforms from bluish (cool) white to yellowish (warm) white. [16]

6. **New Oxide Phosphor for White LEDs:** $\text{Y}_3\text{Al}_5\text{O}_{12}:\text{Ce}^{3+}$ (YAG:Ce³⁺) Many patents refer towards this phosphor for usage as a color converter along with blue color excitation LEDs. It produces yellow light, and, when mixed with extra blue light, produces a white light that is passable. The peak of the YAG:Ce³⁺ excitation spectrum is around 470 nm. The $\text{Ca}_2\text{NaMg}_2\text{V}_3\text{O}_{12}:\text{Eu}^{3+}$ phosphor is said to be capable for converting a UV LED's emission into highly bright white light. This white light has also high color rendering index. [17-21]
7. **Cathode Ray Tube (CRT):** Phosphors, which are frequently used for CRT screens, are powdered materials with sizes ranging from a few μm to around 10 μm . The information gained from numerous powder coating methods used in the paint & printing industries was essential to develop the optimum method for the phosphor. However, the desired method is required to acquire tougher requirements in order to manufacture worthy phosphor screens, as discussed below. In general, the process of making CRTs begins with the phosphor coating method and is followed by other distinct procedures, like baking and evacuation, to produce the finished tubes. The emitted color and screen efficiency must be controlled while spots, as well as other irregularities caused by impurities present throughout the tube-making procedures, must be avoided. Following extended electron beam bombardment, the resulting goods must also sustain a high degree of performance across their lifetime.
 - **Monochrome Screen:** They can be found in black-and-white television tubes, monochrome monitor, oscilloscope, and distinct projection tubes (red, green and blue) used in color television. In this context, monochromatic refers to one color that spans the full tube screen. To get the desired color, multiple phosphors are frequently blended.
 - **Multilayer Screen:** This category involves radar tubes and penetration tube screens. Depending on tube requirement, phosphors of various emission colors are coated layer by layer, with/without an insulating film between surrounding layers.
 - **Mosaic Screen:** Such screens are designed for color monitor tubes and color television, and they are quite promising in terms of technology. Phosphors of

various emission colors (blue, red and green) are coated in thin two-dimensional patterns of faceplate glass. For examples, mosaic screens composed of aforesaid colors are of type types: (a) dot and (b) stripe configuration.

8. Display Units: Displays are critical information-age gadgets that serve as the ultimate interaction between information sources like laptops, the internet, or television as well as the human visual system. Many other display technologies have been invented since the invention of the "Braun tube" more than a century ago. For a long time, the "Braun tube," also recognized as the CRT, was the most widely used display technology. We are currently in a transition era toward flat panel displays, with CRTs being increasingly replaced by newer technologies, including liquid crystal displays (LCDs) and plasma display panels (PDPs). Frequently speaking, the PDPs are the most promising technology for screen sizes bigger than 40 inches.. PDPs rely on luminous materials as an emissive display technology, which implies that many performance requirements, like brightness, color gamut, efficiency, and lifespan, are dictated by these functional materials. Attention must be given to the present phosphor materials in use, as well as their major issue areas. Because of their simplicity of production and durability, phosphors based on oxide matrices are appealing host materials for the development of improved phosphors. For several decades, researchers in the field of display have been interested in the luminescence of materials doped with rare-earth ions. Display advancements like LCDs, thin-film electro-luminescent (TFEL), field emission displays (FEDs) and PDPs devices have always been accompanied by advancements in the phosphor utilized. Significant efforts have been done to identify novel host materials and high-performance activators for phosphor applications.

- **Working Principle for PDPs:** Plasma discharge displays have been well recognized since the early ninetens . In essence, all plasma displays utilized a basic neon light discharge. A closed glass container is packed with rare gas and neon combinations (for example, 10% Xe and 90% Ne), and a plasma is created by delivering enough high voltage across cathode and anode. In PDPs, both AC and DC discharges were employed. Initially, the neon light discharge's orange or red light was employed directly for monochrome display applications.
- **Flat Panel Display:** Rare-earth stimulated oxide phosphors are used in flat panel displays that are high-energy photo luminescent. Aforesaid phosphors are made up of a host, with high insulation here fluorescence produced by the $3d \rightarrow 3d$, $5d \rightarrow 4f$ or a $4f \rightarrow 4f$ transitions in rare-earth ions or transitions in transition metals. Fabrication of complicated host compositions such as Y_2SiO_5 , $Y_3Al_5O_{12}$, Y_2O_3 , and $BaMgAl_{10}O_{27}$, as well as regulated concentrations of activators (Cr³⁺, Mn²⁺, Ce³⁺, Eu²⁺, Eu³⁺, Tb³⁺, Tm³⁺), is still a goal that needs to be accomplished. For high luminous efficiency and resolution in modern flat panel display innovations, the following properties are required: high purity, homogenous compositionally, single-phase, tiny and uniform particle size powders. Phosphors are the visible region -light-producing components of fully colored flat panel displays [22]. Small particle size powders which are thermally stable, have high luminescence efficiency, are resistant to radiation are essential for use in the growing full color, flat panel display technology. The requirements of these advanced technologies have resulted in a desire for novel materials and production procedures to increase phosphor performance.

Oxide phosphors were recognized as be the optimum choice for field emission display (FED) and PDPs systems. A FED works with lower energy (3 to 10 keV) and greater current density beams falling on the surface of phosphors than a CRT. This necessitates the usage of more luminous efficiency and high thermal stability of materials. Luminous efficiency is expressed as the ratio of output energy with the input energy. In PDPs, very energetic photons (145nm, 8.0 eV) are struck on the phosphor particle, causing a decrease in luminous efficiency over time due to radiation damage generated in the material.

VI. CONCLUSION

Our intention in writing this chapter on metal oxide phosphors and their properties was to give readers a sense of the fundamentals, the breadth, and the diversity of this research topic. We have made an effort to highlight the primary research areas now being pursued as well as the most crucial issues, particularly those that still require significant developments or breakthroughs. We believe it is crucial to emphasise that the study of inorganic materials for display units is a truly interdisciplinary field that calls for proficiency and inventive research in a variety of fields of study, including luminescence and optical spectroscopy, inorganic chemistry, solid state physics, and materials science. We have highlighted recent findings in particular and given a snapshot of the significance of in-depth local structural and dynamical examinations of phosphors like Y_2SiO_5 , $Y_3Al_5O_{12}$, Y_2O_3 , etc. Although YAG and other metal oxide-based host lattices are still regarded as very promising materials, it should be mentioned that numerous other classes of phosphors have been produced and are currently receiving more attention.

REFERENCES

- [1] Zhuang, W., Hu, Y., Liu, R., & Zhong, J. (2017). Oxide Phosphors. In *Phosphors, Up Conversion Nano Particles, Quantum Dots and Their Applications* (pp. 247-264). Springer, Berlin, Heidelberg.
- [2] Kumar, V., Tiwari, S. P., Ntwaeaborwa, O. M., & Swart, H. C. (2020). Luminescence properties of rare-earth doped oxide materials. In *Spectroscopy of Lanthanide Doped Oxide Materials* (pp. 345-364). Woodhead Publishing.
- [3] Kumari, S., & Sahare, P. D. (2013). Photoluminescence Study of Laser Grade POPOP Dye Incorporated into MCM-41. *Advanced Porous Materials*, 1(1), 114-121.
- [4] Kang, T., Park, J., Park, B., Lim, J., Kang, H., Jeong, H., & Kim, J. (2020, August). P213: Late News Poster: Electroluminescence of Oxide Phosphor in Metal Oxide Semiconductor Structure. In *SID Symposium Digest of Technical Papers* (Vol. 51, No. 1, pp. 1787-1789).
- [5] Oh, S. I., Lee, H. S., Kim, K. B., & Kang, J. G. (2010). Protective Metal Oxide Coatings on Zinc-sulfide-based Phosphors and their Cathodoluminescence Properties. *Bulletin of the Korean Chemical Society*, 31(12), 3723-3729.
- [6] Chander, H. (2006, October). A review on synthesis of nanophosphors—future luminescent materials. In *Proceedings of ASID* (Vol. 6, pp. 8-12).
- [7] Rani, G., & Sahare, P. D. (2011, December). Synthesis and Luminescent Properties of Li-doped ZnS Nanostructures by Chemical Precipitation Method. In *AIP Conference Proceedings* (Vol. 1393, No. 1, pp. 253-254). American Institute of Physics.
- [8] McKittrick, J., Shea, L. E., Bacalski, C. F., & Bosze, E. J. (1999). The influence of processing parameters on luminescent oxides produced by combustion synthesis. *Displays*, 19(4), 169-172.
- [9] Wang, H., Qian, C., Yi, Z., Rao, L., Liu, H., & Zeng, S. (2013). Hydrothermal synthesis and tunable multicolor upconversion emission of cubic phase Y_2O_3 nanoparticles. *Advances in Condensed Matter Physics*, 2013.
- [10] Wei Zhang, Xianghua Zeng, Hongfei Liu, Junfeng Lu. (2013) Synthesis and investigation of blue and green emissions of ZnS ceramics. *Journal of Luminescence* 134, 498-503.

- [11] Li, Y., Qi, S., Li, P., & Wang, Z. (2017). Research progress of Mn doped phosphors. *RSC advances*, 7(61), 38318-38334.
- [12] Zhang SS, Zhuang WD, He T, Liu YH, Liu RH, Gao WG, Hu YS, Long Z (2010) Study onco-precipitation synthesized Y₃Al₅O₁₂:Ce yellow phosphor for white LED. *J Rare Earths*28:713
- [13] . Fasol, G.; Nakamura, S. *The Blue Laser Diode: GaN Based Blue Light Emitters and Lasers*; Springer: Berlin, Germany, 1997.
- [14] Pimputkar, S.; Speck, J.S.; DenBaars, S.P.; Nakamura, S. Prospects for LED lighting. *Nat. Photonics* 2009, 3, 180–182.
- [15] Cesaria, M., & Di Bartolo, B. (2019). Nanophosphors-based white light sources. *Nanomaterials*, 9(7), 1048.
- [16] Ye, S.; Xiao, F.; Pan, Y.X.; Ma, Y.Y.; Zhang, Q.Y. Phosphors in phosphor-converted white light-emitting diodes:Recent advances in materials, techniques and properties. *Mater. Sci. Eng.* 2010, 71, 1–34.
- [17] Zhang SS, Zhuang WD, Zhao CL, Hu YS, He HQ, Huang XW (2004) Study on (Y, Gd)₃(Al,Ga)₅O₁₂:Ce³⁺ phosphor. *J Rare Earths* 22:118
- [18] Zhang SS, Zhuang WD, Zhao CL, He HQ, Huang XW (2002) Influence of flux on propertiesof Y₃Al₅O₁₂:Ce phosphor. *J Chin Rare Earths Soc* 20:605
- [19] Zhang SS, Zhuang WD, He T, Liu YH, Liu RH, Gao WG, Hu YS, Long Z (2010) Study onco-precipitation synthesized Y₃Al₅O₁₂:Ce yellow phosphor for white LED. *J Rare Earths*28:713
- [20] . Gao WG, Hu YS, Zhuang WD, Zhang SS, Liu YH, He HQ (2009) A Novel Method for thesynthesis of YAG:Ce phosphor. *J Rare Earths* 27:886
- [21] Hou YK, Huang XW, Liu YH, Zhuang WD, Long Z, Hu YS (2008) Synthesis of rare earthoxide precursors and study on its effect on YAG:Ce phosphor. *J Chin Rare Earths Soc* 26:609
- [22] Yu ZJ, Huang XW, Zhuang WD, Cui XZ, Li HW (2005) Crystal structure transformation and luminescent behavior of the red phosphor for plasma display panels. *J Alloys Compd* 390:220