

INTERNET TECHNOLOGIES AND SECURITY ISSUES

Abstract

A new paradigm known as Internet technologies has transformed the old way of life into a high-tech lifestyle. These changes are made possible by IT and include smart homes, smart cities, energy conservation, pollution reduction, smart industries, and smart transportation. Many important research projects and investigations have been carried out in an effort to advance technology using various technologies. To fully realise the promise of IT, there are still many obstacles and problems that must be resolved. These difficulties and problems must be taken into account from a variety of IT perspectives, including applications, difficulties, enabling technologies, social and environmental implications, etc. The main goal of this chapter is to give a full discussion from both a technological and societal perspective. The chapter goes through several difficulties and significant problems with Internet technologies, architecture, and significant application domains. The main goal of this chapter is to outline information technology, including prospects for Internet use to gain competitive advantages and how they might facilitate the secure transit of information.

Keywords: Internet Technologies, transmission medium, wireless technologies, standard protocols, security keys.

Author

Madhavi Sadu

Assistant Professor

Information Technology Department

RCERT, Chandrapur, India

ssmadhavi09@gmail.com

I. BACKGROUND OF INTERNET

- 1. Internet:** The Internet technology is an all-over world-wide connection of interconnected PC organizations that utilization the defined Internet Protocols (TCP/IP) to connect billions of clients all over the world. An organization has millions of clients such as private, public intellectual, business, and other government organizations. Since there are presently a huge number of PCs engaged with the Internet, it has become a significant method for correspondence and considers clients to cooperate with little respect to particular distance or area. Related with the Internet is a bunch of innovations going from network conventions to programs that have been created to help Internet tasks. This Chapter gives a depiction of the premise of these Internet innovations and how these can be utilized by companies to work on their tasks.
- 2. WWW:** The World Wide Web, curtailed as WWW and generally called as the Web, is an arrangement of interlinked hypertext records got to by means of the Internet. With an internet browser, one can see pages that might contain text, pictures, recordings, and other mixed media and explore between them by means of hyperlinks.
- 3. Development of web:** Between the summers of 1991 and 1994, the heap on the main Web server ("info.cern.ch") rose consistently by an element of 10 consistently. In 1992 scholarly world, and in 1993 industry, was paying heed. Internet Consortium is framed in September 1994, with a base at MIT is the USA, INRIA in France, and presently likewise at Keio University in Japan. With the sensational surge of rich material of various sorts onto the Web during the 1990s, the initial segment of the fantasy is to a great extent understood, albeit still not very many individuals practically speaking approach natural hypertext creation devices. The subsequent part presently can't seem to occur, however there are signs and plans which make us certain. The incredible requirement for data about data, to assist us with ordering, sort, pay for own data is driving the plan of dialects for the web intended for handling by machines, instead of individuals. The snare of intelligible report is being converged with a trap of machine-justifiable information. The capability of the combination of people and machines cooperating and imparting through the web could be huge.
- 4. WEB servers:** Ooverview and peruse pages on the Web, all you want is an internet browser. To distribute pages on the Web, you really want a web server. A web server is the program that sudden spikes in demand for a PC and is liable for answering to internet browser demands for records. You really want a web server to distribute records on the Web. At the point when you utilize a program to demand a page on a site, that program makes a web association with a server utilizing the HTTP protocol. The program then, at that point, organizes the data it got from the server. Server acknowledges the association, sends the items in the mentioned records and afterward closes.
- 5. WEB browsers:** A web browser is the program you use to see pages and explore the World Wide Web. A wide cluster of internet browsers is accessible for pretty much every stage you can envision. Microsoft Internet Explorer, for instance, is incorporated with

Windows and Safari is incorporated with Mac OS X. Mozilla Firefox, Netscape Navigator, and Opera are accessible free of charge.

6. **What the browser does:** The centre motivation behind an internet browser is to interface with web servers, demand records, and afterward appropriately organization and show those reports. Internet browsers can likewise show records on your neighbourhoods PC, download documents that are not intended to be shown. Each site page is a record written in a language called the Hypertext Markup Language (HTML) that incorporates the text of the page, a portrayal of its design, and connections to different reports, pictures, or different media.
7. **Protocols:** In computing, a protocol is a bunch of rules which is utilized by PCs to speak with one another across an organization. A convention is a show or standard that controls or empowers the association, correspondence, and information move between computing endpoints.
8. **Internet protocol suite:** The arrangement of Internet Protocol Suite interchanges conventions, utilized for the Internet and other comparable organizations. It is normally called TCP/IP named from two of the main conventions in it: The Transmission Control Protocol (TCP) and the Internet Protocol (IP), which were the initial two systems administration protocols characterized in this norm.
9. **Building web sites:** It's smart to initially ponder and plan your site. Like that, you'll provide yourself guidance and you'll have to revamp less later.
To design your site:
 - Sort out why you're making this site. What is it that you need to convey?
 - Ponder your crowd. How might you fit your substance to interest this crowd? For instance, would it be a good idea for you to add bunches of illustrations or is it more critical that your page download rapidly?
 - What number of pages will you want? What kind of construction could you like it to have? Do you maintain that guests should go through your site in a specific bearing, or would you like to make it simple for them to investigate toward any path?
 - Sketch out your site on paper.

II. ISO Model (TCP/IP)

There are n quantities of clients who use PC organization and are situated over the world. Along these lines, to guarantee, public and overall information correspondence, frameworks should be created which are viable to speak with one another. ISO has fostered this. ISO represents international association of Standardization. This is known as a model for Open System Interconnection (OSI) and is regularly known as OSI model. The ISO-OSI model is a seven- stages architecture. It is designed by seven stages or levels in a total inter - connected framework.

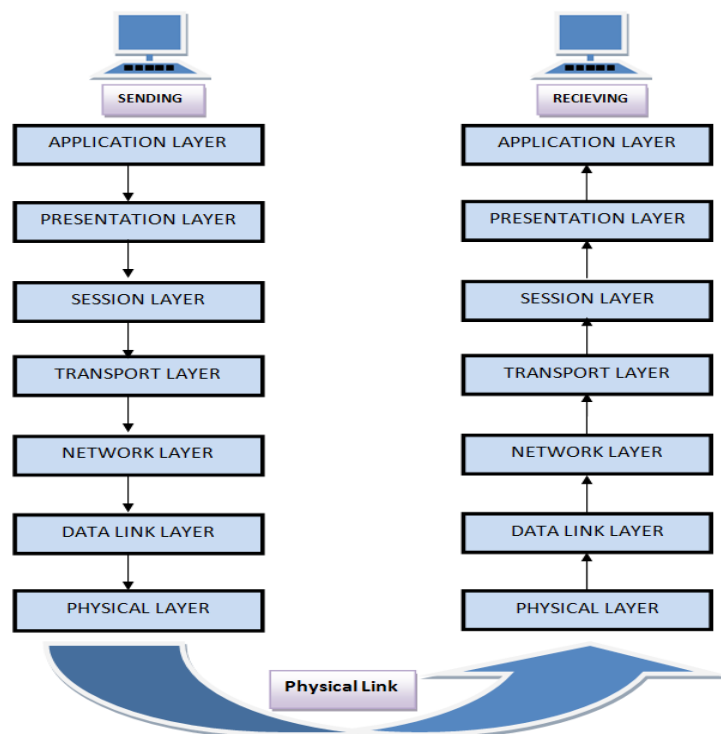

1. **Physical layer:** It is obligated for sending pieces beginning with one PC then onto the following. This layer isn't stressed over the significance of the pieces and deals with the real relationship with the association and with transmission and social occasion of signs. It characterizes Physical subtleties addressed as 0 or a 1.

Physical layer functions

- **Portrayal of bits:** Information or data sets in this stage comprises of string of pieces. The pieces ought to be encoded to signals for transferring data bits. It defines the kind of encoding i.e., 0's and 1's is changed to flag.
- **Data rate:** In this layer characterizes the pace of transmission is the quantity of pieces each second.
- **Synchronization:** It manages and act as a transmitter and recipient. The source and collector are synch at bit level.
- **Interface:** The first layer characterizes the transmission of bits through interface among gadgets and transmission channel.
- **Line configuration:** The layer associates gadgets with: Point to Point arrangement and Multiple - point design.
- **Topologies:** It should be associated utilizing the accompanying Topologies: Star, Mesh, Bus and Ring.
- **Transmission modes:** It characterizes the heading of conversion between two gadgets: Simplex, Half and Full Duplex.

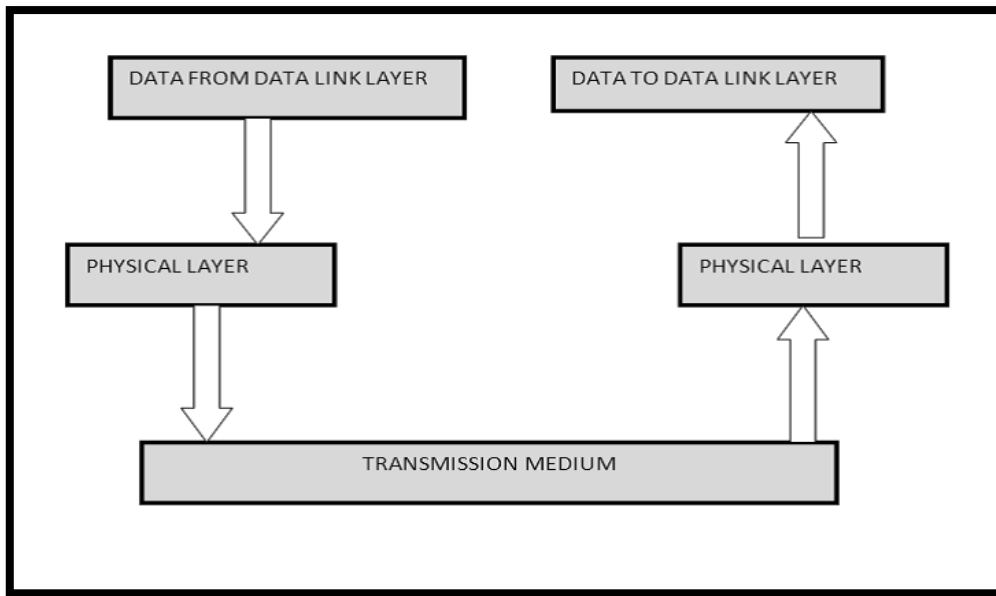

2. **Data link layer:** This layer is the significant strong centre to centre point transport of data. It structures outlines from the packs that are gotten from network layer and gives it to genuine layer. It moreover synchronizes the data which is to be sent over the information. Botch controlling is handily wrapped up. The encoded information is then passed to certified layer.

Error acknowledgment pieces are utilized by the information interface layer. It also rethinks the blunders. Dynamic messages are assembled into outlines. Then, at that point, the design accepts that the affirmations will be gotten after the transmission. Sending message is dependable.

Functions of data link layer

- **Framing:** Outlines are the floods of pieces got from the organization layer into reasonable information units. This division of stream of pieces is finished by Data Link Layer.
- **Physical addressing:** The Data Link layer adds a header to the edge to characterize actual location of the shipper or recipient of the casing, in the event that the casings are conveyed to various frameworks on the organization.
- **Flow control:** Stream control instrument to avoid a speedy progress from running a drowsy beneficiary by buffering the extra piece is given by stream control. This thwarts gridlock at the gatherer side.
- **Error control:** It is achieved by adding a beginning stage close to the completion of the edge. Duplication of housings are furthermore hindered by using this framework. It adds instrument to prevent duplication of housings.
- **Access control:** Rules of this layer sort out which of the contraptions has control over the association at some irregular time, when no less than two devices are related with a comparative association.

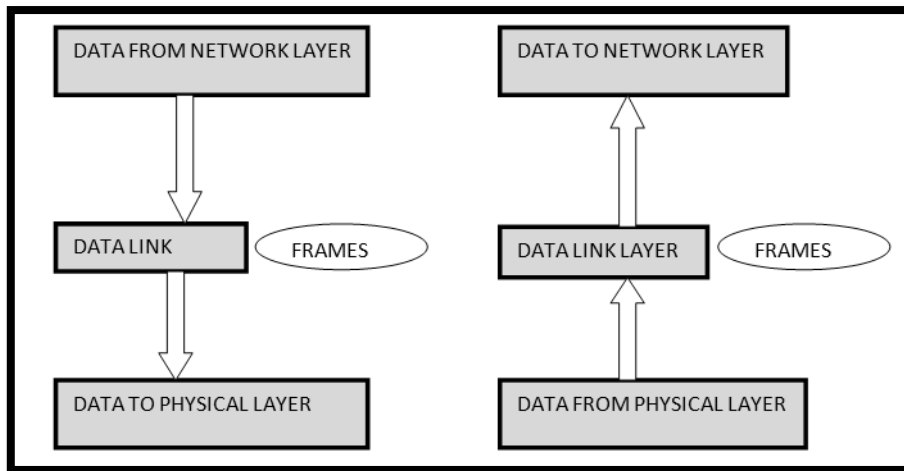

- 3. Network layer:** The fundamental sign of this layer is to give groups from source to valid across various affiliations (affiliations). In the event that two PCs (structure) are connected on a near relationship there is no need for an affiliation layer. It courses the sign through various channels to the far edge and goes likely as an affiliation regulator.

It furthermore disconnects the dynamic messages into groups and to accumulate moving toward bundles into messages for additional raised levels.

Network layer functions

- It makes an understanding of shrewd association address into real area. Stressed over circuit, message or package trading.
- Switches and entrances work in the association layer. Framework is given by Organization Layer to controlling the packages to convincing goal.
- Affiliation organizations are given including network layer stream control, network layer bumble control and group course of action control.
- Breaks greater packs into little packages.

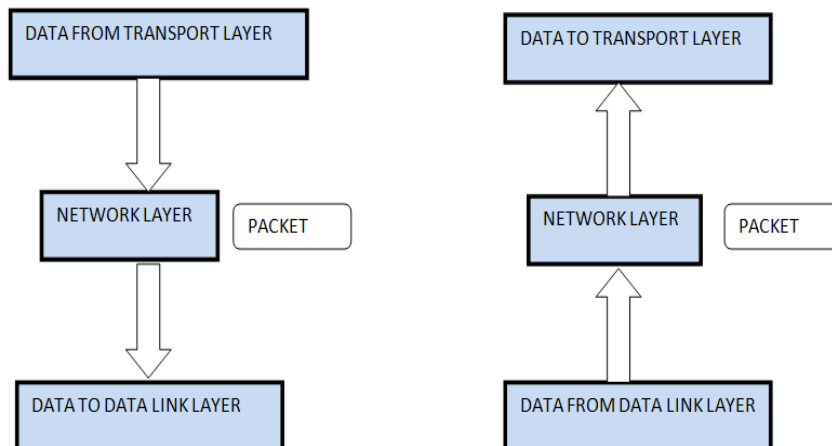

- 4. Transport layer:** The central sign of transport layer is to give the whole message from source to objective. Transport layer guarantees entire message seems awesome and all together, guaranteeing both screw up control and stream control at the source to real even out. It picks expecting information transmission ought to be on comparable way or single

way Transport layer breaks the message (information) into little units so they are overseen considerably more productively by the affiliation layer and guarantees that message shows up all together by checking mix-up and stream control.

Transport layer functions

- **Administration Point Tending to:** Transport Layer header coordinates association point address which is port region. This layer receives the message to the right cycle on the PC not a tiny smidgen like Association Layer, which gets each pack to the right PC.
- **Division and reassembling:** A message is secluded into sections; each part contains gathering number, which empowers this layer in reassembling the message. Message is reassembled exactly subsequent to showing up in the objective and replaces packs which were lost in transmission.
- **Association control:** It integrates 2 sorts:
 - Connectionless Transport Layer: Each piece is considered as a free pack and passed on to the vehicle layer at the goal machine.
 - Connection Oriented Transport Layer: Prior to conveying packages, affiliation is made with transport layer at the goal machine.
- **Flow control:** In this layer, stream control is performed beginning to end.
- **Error control:** Mistake Control is performed beginning to end in this layer to ensure that the complete message appears at the getting transport layer with close to no screw up. Botch Remedy is done through retransmission.

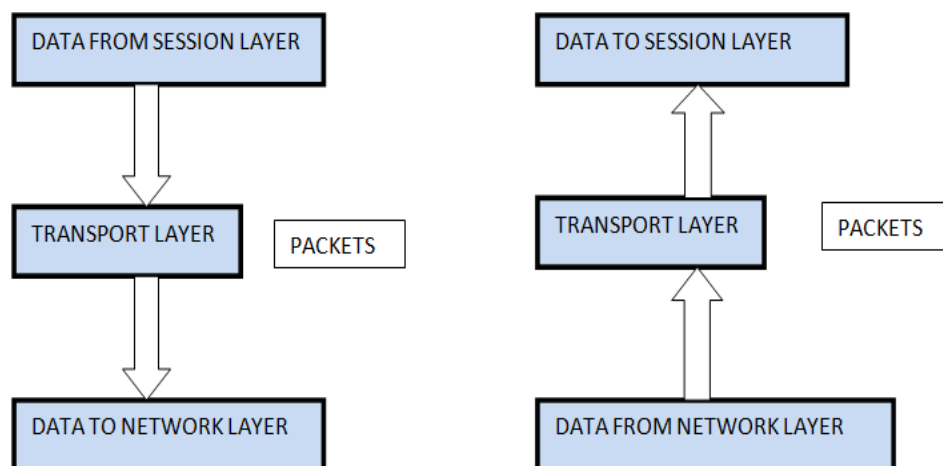

5. **Session layer - OSI model:** Its fundamental point is to lay out, stay aware of and synchronize the association between conveying structures. Meeting layer regulates and synchronize the discussion between two novel applications. Move of information starting with one objective then onto the accompanying get-together layer surges of information are checked and are resynchronized fittingly, so the terminations of the messages are not cut imprudently and information misfortune is kept away from.

Session layer functions

- **Dialog Control:** This layer permits two frameworks to begin correspondence with one another in half-duplex or full-duplex.
- **Synchronization:** This layer permits a cycle to add relegated spots which are considered as synchronization focuses into stream of information. Model: If a design is sending a report of 800 pages, adding doled out spots after each 50 pages is proposed. This guarantees that 50-page unit is really gotten and seen. This is valuable at the hour of crash like a disaster occurs at page number 110; there is persuading clarification need to retransmit 1 to100 pages.

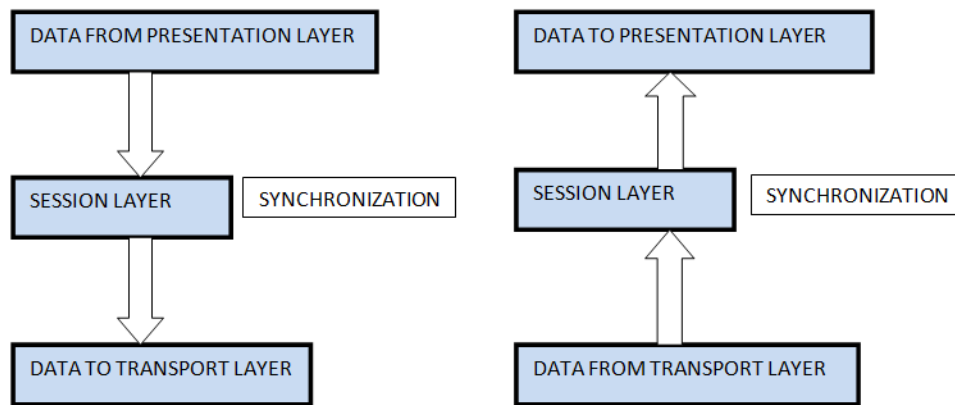

6. **Presentation layer:** The principal objective of this layer is to deal with the sentence plan and semantics of the data traded between two passing on structures. Show layer takes care that the information is sent so the recipient will figure out the data (information) and will truly have to utilize the information. Tongues (sentence structure) can be different of the two giving frameworks. Under this condition show layer anticipates a part interpreter.

Presentation layer functions

- **Translation:** Preceding being sent, data as characters and numbers ought to be changed to bit streams. The show layer is liable for interoperability between encoding frameworks as various PCs utilize different encoding techniques. It disentangles information between the blueprints the affiliation requires and the course of action the PC.
- **Encryption:** It finishes encryption at the transmitter and interpreting at the beneficiary.
- **Compression:** It finishes data strain to reduce the exchange speed of the data to be imparted. The fundamental occupation of Information pressure is to lessen the number of pieces to be Otransmitted. It is critical in sending blended media, for instance, sound, video, message, etc

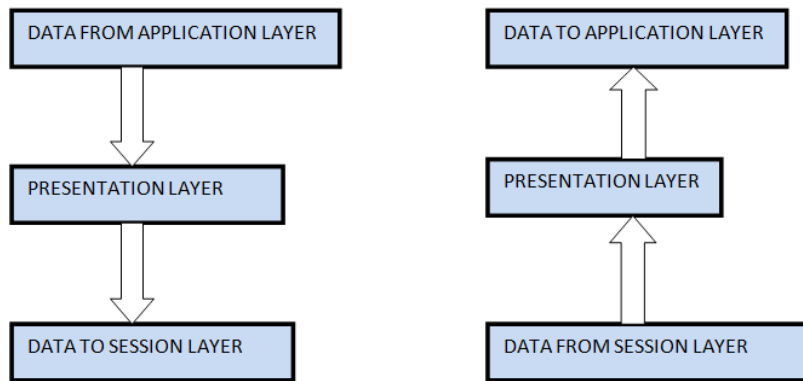

7. Application layer: It is the first layer of OSI Model. Control of data (information) in various ways is done in this layer which engages client or programming to acquire permission to the association. A couple of organizations given by this layer integrates: Email, moving of records, coursing the results to client, library organizations, network resource, etc.

Application layer functions:

- **Mail Services:** This layer gives the reason to Email sending and amassing.
- **Network virtual terminal:** t allows a client to sign on to a remote host. The application makes programming replicating of a terminal at the remote host. Client's PC banter with the item terminal which in this manner chats with the host as well as the opposite way around.

Then the remote host acknowledges it is talking with one of its own terminals and grants client to sign on.

- **Index services:** This layer gives induction to overall information about various organizations.
- **Document transfer, access and management (FTAM):** It is a standard part to will records and regulates it. Clients can will records in a distant PC and direct it. They can moreover recuperate records from a far-off PC.

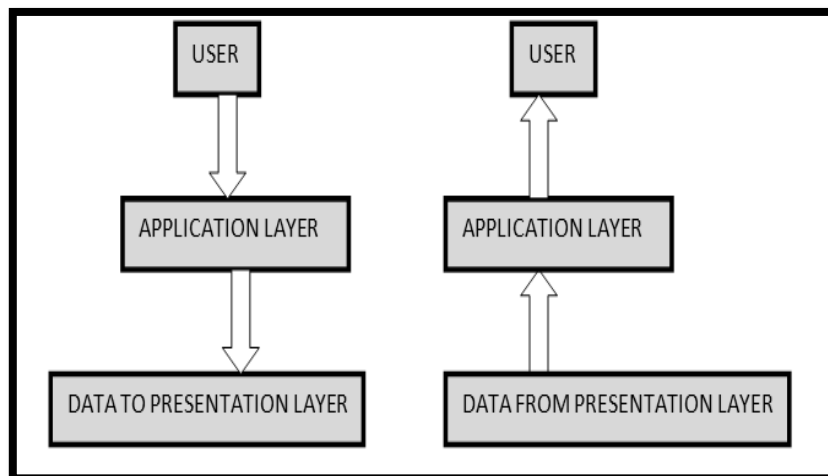

8. Feature of OSI model:

- Extremely huge picture perspective on correspondence over network is sensible through this OSI model.
- We see how hardware and programming coordinate.
- We can see new advancements as they are made.
- Researching is more direct by free associations.
- Can be used to contemplate crucial valuable associations on different associations.

9. **Transmission mediums:** Information is addressed through computers and other gadgets using signals. Signals are sent as electromagnetic energy through one gadget to the next. Electromagnetic signs send from vacuum or other transmission mediums to go between each other (from source to beneficiary).

Through Transmission medium we can send our data beginning with one spot then onto the following. The essential layer (genuine layer) of Correspondence Organizations OSI layers model is dedicated through the transmission media.

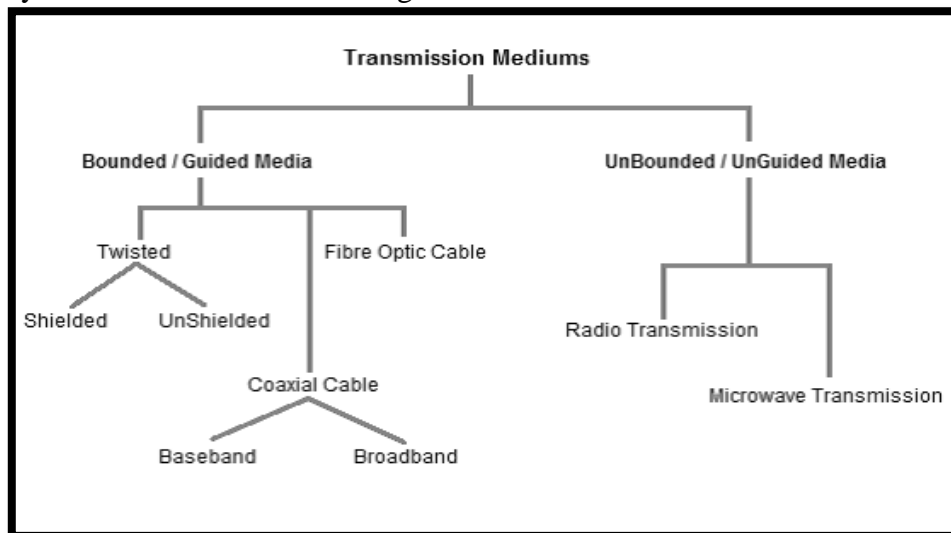

III. WANS

WAN is a media correspondences association organization to a huge geographical distance. Wide locale networks are typically settled with rented telecom circuits.

Business, direction and government parts utilize wide locale relationship to give information among staff, understudies, clients, purchasers, and providers from different land districts. Basically, this strategy for telecom gives a business to genuinely do its ordinary limit paying little notification to locale.

Related expressions for different kinds of organizations are PANs, LAN, CAN, or MAN are normally giving range to a room, one-building, grounds or other metropolitan region individually.

WANs are utilized to relate LANs and various types of associations with other, so clients and PCs in a one region can speak with clients and PCs in various regions. Such countless WANs are worked for one unambiguous affiliation and are private.

1. WAN Technologies

- **Internet Applications:** Web Applications can be portrayed as the kind of utilizations that utilization the web for working effectively, or at least, by involving the web for bringing, sharing and showing the data from the individual server frameworks. It tends to be gotten to just with the assistance of the web office, and it can't be practical without the web. These applications can be named electronic gadgets based, computerized advanced innovation, modern web, cell phones based, shrewd locally established, brilliant frameworks, savvy city, and other significant applications.
- **Services of Internet Application**
 - The web has numerous couples of significant applications like electronic mail administrations, web perusing, distributed systems administration. The utilization of email expands on account of its few highlights like connections, messages, information use.
 - The connection element, for example, word reports, succeed sheets, and graphical media is conceivable on account of Multipurpose Internet Mail Extensions, yet the outcome is traffic volume brought about via mail is aligned with regards to information parcels in the organization.
 - Electronic mail administrations turned into an imperative piece of individual and expert specialized technique, and now is the ideal time and cost consuming. The information is sent and gotten safely by encryption. The cost of tickets for transport and game are gotten via the post office.
 - The internet browser is a basic utilization of the web and is profoundly business overwhelmed by Microsoft and exceptionally impacted by WWW - World Wide Web ,Top Application of Internet [8].

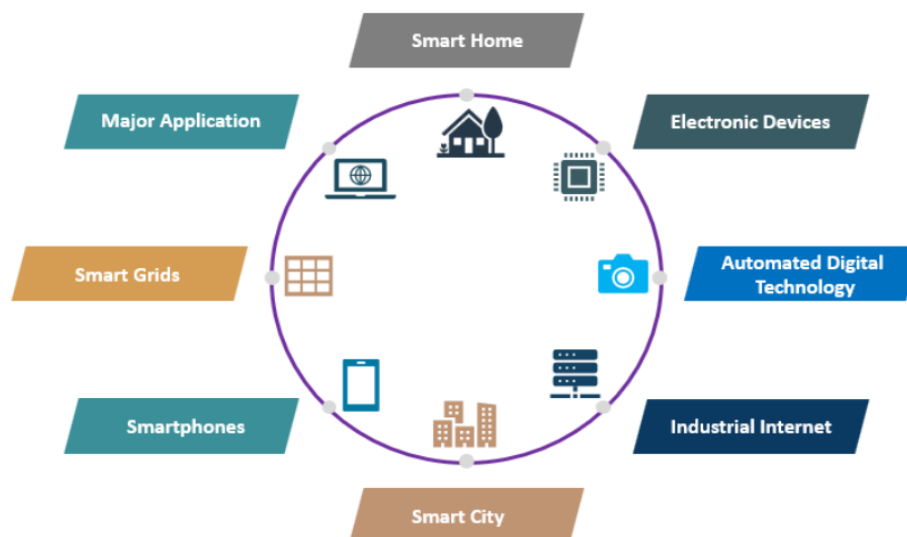

- **Smart Home:** Smart Home has turned into the developmental stepping stool in private and creating as normal as cell phones. It is an exceptional component of

Google and presently sent in numerous areas to make life helpful and easy to use. The shrewd home is intended to save time, cash and energy.

- **Electronic Devices:** Electronic gadgets like wearables are introduced with various sensors and programming, which assemble information and data of the client where information is handled to give required information about the client. The gadgets primarily used to screen wellness, diversion, and wellbeing. They for the most part work on super low power and accessible in little sizes.
- **Automated digital technology:** The robotized computerized innovation has focused on the streamlining of vehicles and their inside capabilities. the mechanized vehicle is planned with unique highlights that give a safe place to travellers with installed sensors and web foundation. Well known organizations like Tesla, Apple, BMW, Google is yet to on board their upheaval in the vehicle business by introducing amazing elements.
- **Industrial internet:** The modern web is putting resources into modern designing with Artificial knowledge and information investigation to assemble splendid machines. The significant moto is to construct shrewd machines that are exact and viable with a human. It holds immense potential with great quality and dependability. The applications are sent for following the product to be passed on, constant data as for retails and supplies that increase the adequacy of the business' stock organization and proficiency.
- **Smart city:** A wise city is another critical execution of the web, which is used for splendid surveillance, water scattering, modified transportation, environment noticing. People are leaned to pollution, rash supplies and absence of sources, and the foundation of traffic sensors tends to capricious traffic stream, and the application is made to report the metropolitan structures. Occupants can prepare to dissect essential breakdowns in meter and can pay all due respects to the power structure through power load up applications or destinations, and they can moreover find open spaces for vehicle leaving really in sensor systems.
- **Smartphones:** Cell phones are likewise used for retailers and clients to remain related for their arrangements, even out of the store. They have utilizing Beacon innovation to assist business with peopling to offer brilliant support to the client. They can follow the items and upgrade the store dashboard and convey premium request before the planned date, even in blocked rush hour gridlock regions.
- **Smart grids:** The thought applied in savvy networks is to assemble information in a robotized method for breaking down the property of power. Buyers to work on the productivity and financial matters of utilization. Brilliant matrices can without much of a stretch recognize the blackout and lack rapidly and fix them presently.
- **Major application:** Another huge usage of the web is in clinical consideration as it is shrewd clinical structures acquainted with break down and fix the disorder at an earlier stage. Numerous man-made intelligence computations are used in picture dealing with and request to perceive the undeveloped organism's peculiarities before

birth. The fundamental point applied in the clinical field is to give a better life to all by wearing associated gadgets. The assembled clinical information of patients made the treatment simpler, and a checking gadget is introduced to follow the sugar and circulatory strain.

- **Standard protocols:** Standard conventions are concurred and acknowledged by the entire figuring industry. Standard conventions are not merchant explicit. Standard conventions are in many cases created by cooperative exertion of specialists from various associations. Instances of standard conventions are IP, TCP, UDP and so on.
2. **TCP/IP:** TCP/IP is the most usually utilized network convention overall and all hubs associated with the Internet use it. TCP/IP comprises of the 3 fundamental conventions TCP (Transmission Control Protocol), UDP (User Data Protocol) and IP (Internet Protocol). UDP is a less significant convention utilizing the lower-level Protocol IP too. Computer Networks" by Andrew Tanenbaum [5].

- **Establishing TCP Connections**

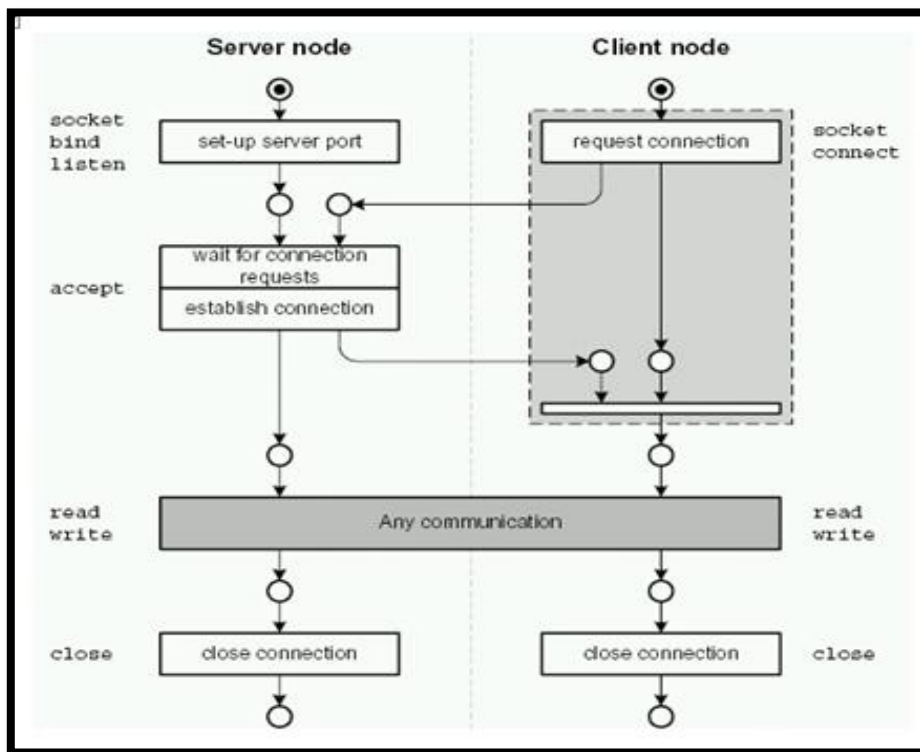

Figure 1: Establishing and finishing a TCP connection.

A TCP association must be laid out between two hubs: A client hub sending an association demand and a server hub hanging tight for such association demands. In the wake of getting an association demand, the server will answer and lay out the association. Then the two hubs can send and get information through the association, contingent upon the application convention. At the point when gotten done, any hub (yet generally the client) can close the association. This conduct is displayed in figure 5.1. Here you additionally see the working framework calls used to control the attachments.

- **Security issues:** A security issue is any outright gamble or weakness in your framework that programmers can use to cause harm to frameworks or information. This remembers weaknesses for the servers and programming interfacing your business to clients, as well as your business cycles and individuals. Despite the fact that Internet prompted many advantages, it likewise represents a more prominent potential for security dangers. The following are various normal Internet security issues [12].

Hacker: alludes to an individual who can acquire unapproved admittance to (break into) a PC or an organization to carry out violations.

A few things a gifted programmer can do to your PC:

- Seize your usernames and passwords;
- Get sufficiently close to the individual data (Mastercard numbers, financial balance, Social Insurance Number, and so on.);
- Take, change, exploit, sell, or annihilate information;
- Harm or cut down the framework;
- Keep the framework prisoner to gather emancipate;

Malware: Malware (short for noxious programming) - a product that is intended to harm, upset, or contaminate PCs.

- Malware is a solitary term that alludes to every one of the various kinds of dangers to your PC security like infection, Trojan pony, worm, spyware, and so forth.
- Malware can acquire unapproved admittance to a PC and ceaselessly run behind the scenes without the proprietor's information.

Computer virus: Computer virus - a particular kind of malware that is intended to reproduce (duplicate) and spread starting with one PC then onto the next.

- An infection can make a duplicate of itself again and again.
- An infection can spread starting with one PC then onto the next through email connections, removable capacity gadgets, organizations (Internet informing administrations, download contaminated documents ...), and so forth.
- An infection can harm your PC by tainting framework documents, sending spam, taking information and individual data from your PC, obliterating information, erasing everything on your hard drive, and so forth.

- **Trojan horse:** Trojan horse (or Trojan) - a sort of malware that looks innocuous however can hurt a PC framework.

- A Trojan deceives clients of its actual plan.
- A Trojan might profess to dispose of your PC infections however rather present infections onto your PC.
- A Trojan can appear as blameless looking email connections, downloads, and so on.

- **Worm:** Worm - it is like an infection (a sub-class of an infection). It is intended to rapidly self-recreate and spread duplicates of itself starting with one PC then onto the next.
 - The vital distinction between a worm and an infection is that a worm requires no human activity to repeat while an infection does. An infection possibly spreads when a client opens an impacted document while a worm spreads without the utilization of a host record.
 - **Phishing:** Phishing - a trickster utilizes misleading messages or sites and attempts to get important individual data (i.e., username, secret word, account number, and so on.).
Phishing is a typical internet-based trick utilized by digital hoodlums.
A trickster might utilize a misleading email or site seeming to address a real firm.
- **Spyware:** A product that covertly screens (sees) client's internet-based conduct and gets delicate data about an individual or association without the client's information.
 - A spyware can record a client's Web perusing propensities, email messages, keystrokes on internet-based promotions, individual data, and so on, and forward it to an outsider.
 - Sponsors can utilize spyware to target explicit ads as you would prefer.
 - Criminal associations can utilize spyware to gather monetary data (banking accounts, Visa data, secret phrase, and so on.).

3. Symmetric and Asymmetric Key

Cryptography Terms

- **Encryption:** It is the most normal approach to getting information using cryptography. Information that has been locked this way is encoded.
- **Decryption:** The most common way of opening the encoded data utilizing cryptographic procedures.
- **Key:** A secret like a mystery key used to encode and interpret information. There are such keys used in cryptography.
- **Steganography:** It is really the examination of concealing data from individuals who could sneak around on you. The distinction among steganography and encryption is that the potential snoops can no doubt not uncover there's any advantaged data in any case.

Symmetric encryption

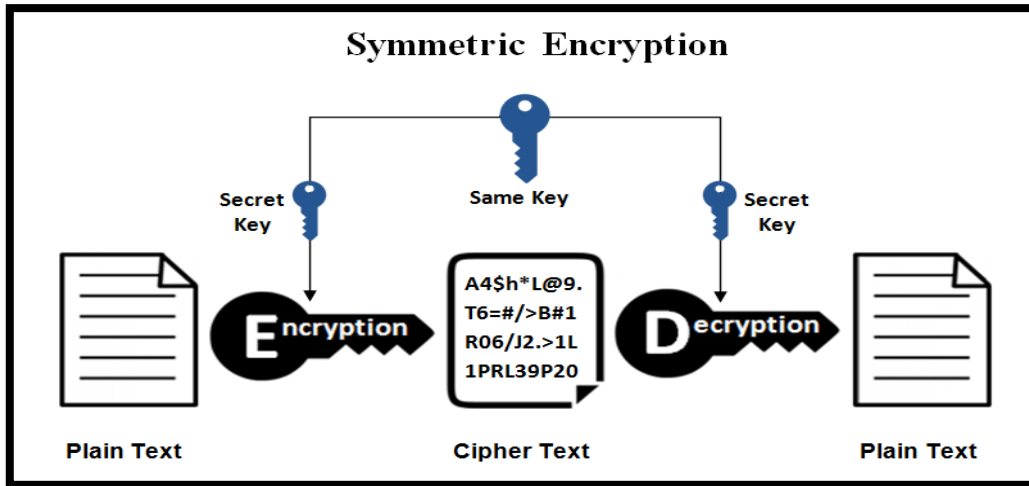

This is the most un-complex kind of encryption that coordinates essentially a solitary secret key to encode and decipher information. Symmetric encryption is an old and most prominent methodology. It uses a secret key that can either be a number, a word or a line of eccentric letters. It is a blended in with the plain message of a message to change the substance pondering a specific objective. The transporter and the recipient should fathom the secret key that is used to scramble and unscramble the messages overall.

Blowfish, AES, RC4, DES, RC5, and RC6 are events of symmetric encryption.

The most generally utilized symmetric calculation is AES-128, AES-192, and AES-256[12].

The important damage of the symmetric key encryption is that all social occasions included need to exchange the key used to scramble the data before they can disentangle it.

Asymmetric encryption: Asymmetric encryption is all things considered called public key cryptography, which is a for the most part new structure, meandered from symmetric encryption.

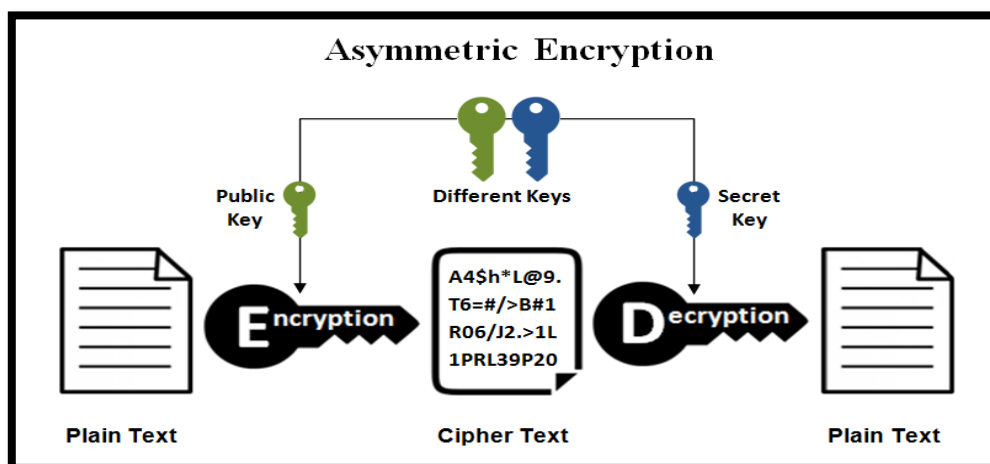

Unequal encryption uses two keys to encode a plain text. Secret keys are exchanged over the Internet or an immense connection. It ensures that toxic individuals don't manhandle the keys. It is critical to see that anyone with a secret key can unscramble the message and to this end disproportionate encryption uses two related keys to aiding security. A public key is made obviously open to any person who ought to send you a message. The resulting secret key is let it be so you can know.

A message that is encoded using a public key should be unscrambled using a secret key, while likewise, a message mixed using a gathered key can be decoded using a public key. Security of the public key isn't required considering how it is vivaciously open and can be disregarded the web. Upside down key has a clearly better power in ensuring the security of information sent during correspondence.

Awry encryption is for the most part utilized in everyday correspondence channels, particularly over the Internet. Well known unbalanced key encryption calculation incorporates EIGamal, RSA, DSA, Elliptic bend procedures, PKCS.

- **Asymmetric encryption in digital certificates:** To utilize unbalanced encryption, there should be a method for managing finding open keys. One normal strategy is remembering modernized affirmations for a client-server model of correspondence. An assertion is a store of data that perceives a client and a server. It contains data, for example, an alliance's name, the association that gave the assertion, the clients' email address and nation, and client's public key.

Right when a server and a client require a safeguarded encoded correspondence, they send a requesting over the relationship to the going with party, which sends back a copy of the declaration. The other party's public key can be isolated from the check. A statement could also at any point be used to surprisingly see the holder.

SSL/TLS utilizes both lopsided and symmetric encryption, immediately take a gander at carefully marked SSL testaments gave by confided in certificate authorities (CAs).

1. Encryption/Decryption

Encryption: Encryption is the procedure by which data is changed over into secret code that conceals the data's certifiable importance. The examination of encoding and unscrambling data is called cryptography [14].

In managing, decoded data is overall called plaintext, and encoded data is called ciphertext. The recipes used to encode and unravel messages are called encryption appraisals, or codes.

To convince, a code facilitates a variable as a piece of the evaluation. The variable, which is known as a key, makes a code's outcome extraordinary. Definitively when an encoded message is gotten by an unapproved substance, the interloper needs to figure which figure the source used to scramble the message, as well as what keys were used as elements. The time and weight of evaluating this information makes encryption such an essential security gadget.

Encryption has been a longstanding way for sensitive information to be gotten. In light of everything, it was used by militaries and law-making bodies. In present day times, encryption is used to defend data set aside on laptops and limit contraptions, as well as data on the way over networks.

- **Important of encryption:** Encryption expects a huge part in getting different kinds of data innovation (IT) assets.
It gives the accompanying:
 - Secrecy encodes the message's substance.
 - Verification confirms the beginning of a message.
 - Uprightness demonstrates the items in a message have not been changed since it was sent.
 - Nonrepudiation keeps shippers from denying they sent the encoded message.
- **Uses of encryption:** Encryption is typically used to defend data on the way and data extremely still. Each time someone uses an ATM or buys something on the web with a mobile phone, encryption is used to defend the information being given off. Associations are continuously relying upon encryption to protect applications and sensitive information from reputational hurt when there is a data break.

There are three critical parts to any encryption system: the data, the encryption engine and the key organization. In PC encryption, all of the three sections are taking off in a comparative spot: on the PC.

In application models, in any case, the three sections commonly take off in discrete spots to reduce the open door that put down some a reasonable compromise of any single part could achieve put down some a reasonable compromise of the entire system.

- **Encryption working steps:** Close to the beginning of the encryption connection, the transporter ought to finish up what code will best veil the meaning of the message and what variable to use as a key to make the encoded message exceptional. The most by and large used sorts of codes fall into two classes: symmetric and Asymmetric.

Symmetric codes, correspondingly recommended as mystery key encryption, utilize a solitary key. The key is once in a while suggested as a commonplace mystery considering the way that the carrier or figuring structure doing the encryption should give the mystery key to all parts supported to decipher the message. Symmetric key encryption is overall a ton quicker than diverged encryption. The most all around utilized symmetric key code is the Undeniable level Encryption Standard (AES), which was supposed to protect government-depicted data.

Asymmetric ciphers, by and large called public key encryption, utilize two exceptional - - yet truly related - - keys. This sort of cryptography consistently utilizes steadfast numbers to make keys since figuring giant insoluble numbers and destroy the encryption is computationally awkward.

Encryption operation

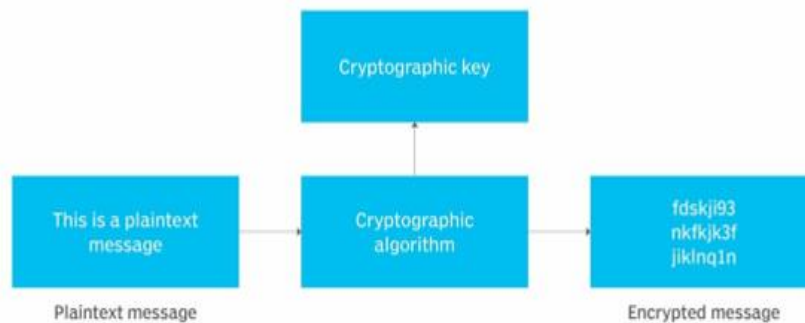

The Rivest-Shamir-Adleman (RSA) encryption calculation is at this point the most all around utilized public key assessment. With RSA, people generally speaking or the confidential key can be utilized to scramble a message; whichever key isn't utilized for encryption changes into the deciphering key.

Today, numerous cryptographic cycles utilize a symmetric calculation to scramble information and a lopsided calculation to trade the mystery key safely.

- **The merits of encryption:** The essential job of encryption is to shield the grouping of cutting-edge data set aside on PC systems or sent over the web or some other PC association.

Despite security, the gathering of encryption is commonly determined by the need to meet consistence rules. Different affiliations and standards bodies either recommend or require fragile data to be mixed to prevent unapproved pariahs or peril performers from getting to the data. For example, the Instalment Card Industry Information Security Standard (PCI DSS) anticipates that vendors should scramble clients' portion card data when it is both taken care of extremely still and sent across open associations.

- **The demerits of encryption:** While encryption is intended to hold unapproved substances back from having the option to comprehend the information they have gained, in certain circumstances, encryption can hold the information's proprietor back from having the option to get to the information too.

Key organization is one of the best hardships of building an endeavor encryption system in light of the fact that the keys to unscramble the code text should dwell some spot in the environment, and aggressors much of the time have an exceptionally shrewd considered where to look.

Decryption: A contrary course of encryption is known as Decoding. It is a procedure of changing Code Text into Plain Text. Cryptography needs the unscrambling technique at the authority side to get the principal message from non-understandable message (Cipher Text) [15].

Decoding work by utilizing the contrary change calculation used to encode the data. A similar key is expected to return the scrambled information to its underlying state.

In decoding, the framework removes and change the jumbled data and change it to texts and pictures that are essentially fathomable by the peruser as well as by the framework. Decoding can be achieved physically or consequently. It can likewise be carried out with a bunch of keys or passwords.

Information can be encoded to make it complex for somebody to take the information. A few organizations likewise encode data for general insurance of organization data and proprietary innovations.

Assuming that this information expected to be perceptible, it can require unscrambling. In the event that an unscrambling password or key isn't open, extraordinary programming can be expected to decode the data utilizing calculations to break the unscrambling and make the information lucid.

There are different types of decryptions are given by :

- **Symmetric decryption:** In symmetric encryption, a similar numerical condition both encodes and unscrambles the data. The accompanying model, a basic letter replacement figure, including $A=B$, $B=C$, and so on.

It is even since it can without much of a stretch converse the interaction to unscramble the message. In the event that it can communicate something specific utilizing a symmetric encryption strategy, the beneficiaries ought to likewise have the way to unscramble the document.

- **Asymmetric decryption:** Asymmetric decryption techniques otherwise called public-key unscrambling. It can utilize a framework including a bunch of associated keys. In this framework, anything encoded with one vital required the other key to unscramble, and so forth.

At the point when it can encode a message utilizing somebody's public key, it can comprehend that main a beneficiary having the relating private key can understand it.

- **Hashing:** Hashing is a type of encryption that need a specific one-way encryption key. In the event that it can hash a given volume of data, it will make a novel result string to that information, however remaking the data from the result string is unimaginable. It can re-encode the first data and contrast it with the outcome string to actually look at it.

This can act as a sort of blunder remedy in encoding. Hashing a message and supporting that worth to the reporters gives that they can hash the actual message and look at the qualities. However long the two result strings match, beneficiaries comprehend the message is full and unaltered.

- **Digital signature:** The utilization of marks is indistinguishable from our regular routines. How not, marks have different significant capabilities for us all, for example, to demonstrate character, keep up with the respectability of a letter or report, or to make rectifications to a letter/record as verification of the endorsement of the change [16].

Then, alongside the improvement of innovation, marks likewise experience advancement and change. The change of this mark comes as a computerized signature. In any case, not all advanced marks have a similar defensive power. What are the distinctions? How would you pick the right kind of computerized signature? Digisign computerized marks have a significant level security framework, but on the other hand are exceptionally down to earth and simple to utilize. Digisign can be utilized whenever and anyplace no matter what your contraption on account of a coordinated stage. Digital signature is of 3 types: Based on the techniques it uses, 3 types of digital signatures are recognized

- **Simple:** A straightforward computerized mark is an advanced mark in its least complex structure since it isn't safeguarded by any encryption strategy. The most well-known model is a wet mark examined by an electronic gadget and afterward embedded into a record. One more illustration of a straightforward computerized mark is the email signature that we frequently add toward the finish of the email, and check the agreements confine the product establishment process.

This straightforward advanced signature has different inconveniences. This mark isn't scrambled so it can't show the underwriter's personality or changes that happen in the report after the archive is agreed upon. Furthermore, basic computerized signature classes are exceptionally simple to copy or phony. Both as far as security and legitimacy, the utilization of computerized marks in this sort isn't suggested.

- **Basic:** Computerized essential marks don't have a lot of contrast contrasted with straightforward computerized marks. The benefits of essential computerized marks from basic advanced marks are just their capacity to show changes that happen after the report is agreed upon. Nonetheless, this mark actually can't ensure the security of your personality since it can't allude to a checked character. In spite of the fact that utilizing the lopsided cryptography technique, essential advanced signature specialist co-ops don't ideally check the client's personality. The marking system is additionally not through 2-factor verification. Accordingly, reports endorsed with computerized marks of this class actually don't have lawful power and legitimate outcomes.
- **Advanced & qualified:** Computerized signature Advanced and Qualified is the most secure advanced signature and has lawful strength comparable to a wet mark on paper. Progressed and qualified advanced level marks are made with lopsided cryptography innovation and public key framework. Very much like a computerized signature in a fundamental class, progressed and qualified advanced level marks are additionally ready to show when, where, and what gadgets to use during the report marking process. Everything changes that happen after the archive is marked can likewise be handily known.

What compels this advanced mark specialist organization more unique is the method involved with checking the personality of the client they are applying. As a matter of fact, high level and qualified computerized signature specialist organizations are expected to force a 2-factor verification before the report can be endorsed by the client. The validation technique utilized likewise changes: from sending one-time passwords through SMS, to biometric checking on cell phones. It is this broad

confirmation and validation process that makes records endorsed with advanced marks this class as of now has an electronic authentication that is interestingly appended to the character of the signatory.

- **Authentication:** Validation is the most common way of confirming the character of a client or data. Client validation is the most common way of checking the personality of a client when that client signs in to a PC system [17].

- **Intranet and extranet**

- **Intranet:** An intranet is a mysterious affiliation that is held inside an endeavor. By and large normal intranet for a business connection includes many interlinked LAN and utilize any WAN improvement for network. The fundamental motivation driving an intranet is to parted affiliation data and selecting assets between delegates. Intranet is a confidential Internetwork, which is commonly made and remained mindful of by a grouped connection. The substance accessible inside Intranet are ordinary exclusively for individuals from that alliance

(Normally representatives of an organization) [18].

- **Extranet:** An extranet should be visible as a part of an association's intranet that is loosened up to clients outside the association like suppliers, merchants, accessories, clients, or other colleagues.

Extranet is typical for standard customary business works out. For instance, submitting buy sales to enlisted sellers, charging and mentioning, segments related resolves, joint endeavor related works out, thing freebees for adornments, limited cost records for associates, and so on.

2. **Consistency, completeness and compactness:** Because of the battles and deals responsiveness of firewall rules, coordinating a firewall clearly as a social gathering of rules encounters these three issues: the consistency issue, the satisfaction issue, and the conservativeness issue. Then, we make sense of these three issues through a key firewall model showed in Figure 1. This firewall lives on a portion change that interfaces a classified relationship to the outside Web. The part switch has two spots of composed exertion: interface 0, which relates the change to the outside Web, and alliance point 1, which relates the change to the gathered association. In this model, we expect that each pack has the going with five fields.

| name | meaning |
|------|-------------------------|
| I | Interface |
| S | Source IP address |
| D | Destination IP address |
| N | Destination Port Number |
| P | Protocol Type |

A firewall Online regularly incorporates hundreds or thousands of rules. Here for facilitate, this firewall model basically has four guidelines. However this firewall don't is near anything, it tends to all of the going with three issues.

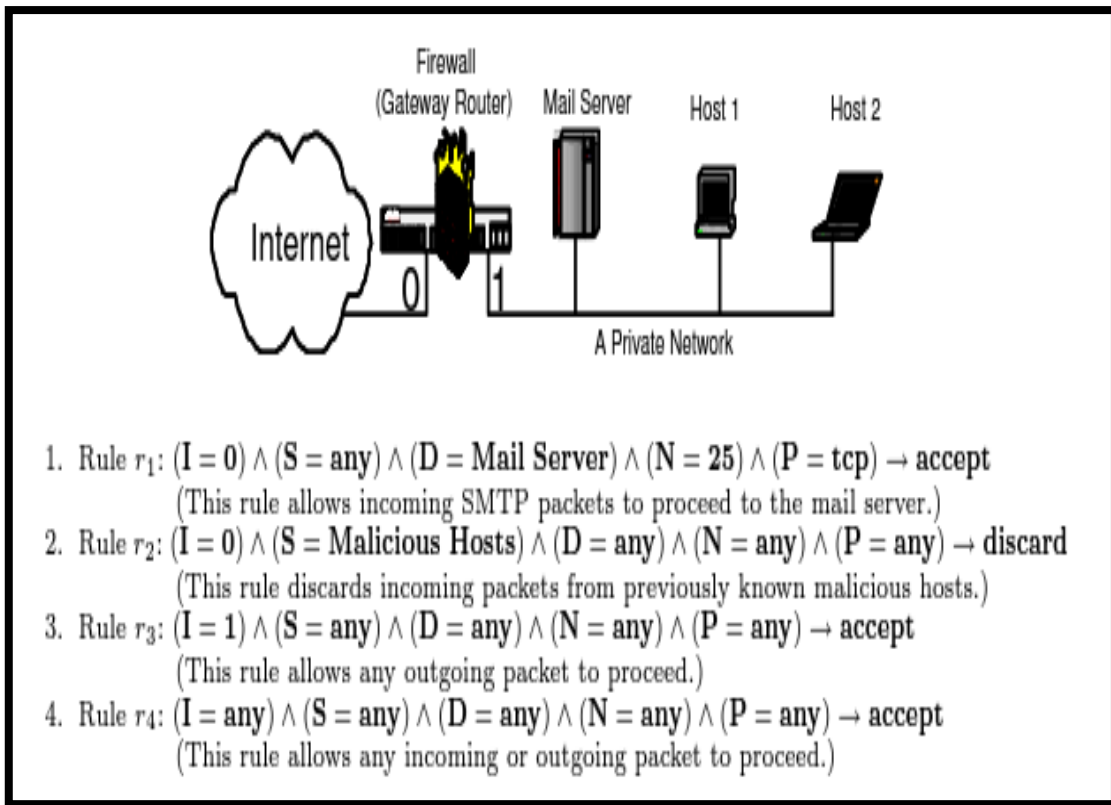

Figure 2: A Firewall Example

Consistency Problem: It is challenging to accurately arrange the guidelines in a firewall. This trouble for the most part comes from clashes among rules. Since rules frequently struggle, the request for the standards in a firewall is basic. The choice for each bundle is the choice of the main decide that the parcel matches. In the firewall model in Figure 1, rule r_1 and r_2 struggle since the SMTP parcels from recently known malignant hosts to the mail server match the two guidelines and the choices of r_1 and r_2 are unique. Since r_1 is recorded before r_2 and the choice of rule r_1 is "acknowledge", the SMTP bundles from recently realized pernicious hosts are permitted to continue to the mail server. Be that as it may, such parcels likely ought to be denied from arriving at the mail server since they start from malevolent hosts. Thusly, rules r_1 and r_2 most likely ought to be traded. As a result of the struggles, the net impact of a standard can't be grasped by the exacting importance of the standard. The choice of a standard influences the destiny of the parcels that match this standard yet matches no standard recorded before this standard. To comprehend one single rule r_i , one requirement to go through every one of the standards from r_1 to r_{i-1} , and for each standard r_j , where $1 \leq j \leq i-1$, one necessity to sort out the legitimate connection between the predicate of r_j and that of r_i . In the firewall model in Figure 1, the net impact of rule r_2 isn't to "dispose of all parcels started from recently known malignant hosts", yet rather is to "dispose of all non-SMTP bundles began from recently known malevolent hosts". The trouble in understanding firewall rules thusly makes the plan and upkeep of a firewall mistake inclined. Upkeep of a firewall for the most part includes embedding, erasing or refreshing guidelines, and revealing the capability of the firewall to others like directors. These errands require exact comprehension of firewalls, which is troublesome, particularly when the firewall chairman is compelled to keep a heritage firewall that isn't initially planned by him.

Completeness Problem: It is endeavoring to ensure that all potential social events are considered. To ensure that each gathering has something like one matching standard in a firewall, the normal practice is to make the predicate of the last rule an accentuation. This is clearly not a successful strategy for ensuring the concentrated idea of every single under the sun pack. In the firewall model in Figure 1, due to the last rule r4, non-email bundles according to an outer point of view to the mail server and email bunches according to an outside viewpoint to the hosts other than the mail server are seen by the firewall. Eventually, these two kinds of traffic undoubtedly should be thwarted. A mail server is usually dedicated to email affiliation just. Right when a host other than the mail server starts to carry on like a mail server, it could a sign that the host has been hacked and it is conveying spam.

Compactness Problem: An ineffectively organized firewall consistently has dull standards. A standard in a firewall is repetitive iff discarding the standard doesn't change the limit of the firewall, i.e., doesn't change the choice of the firewall for each bundle. In the above firewall model in Figure 1, rule r3 is excess. This is on the grounds that each of the packs that match r3 yet don't match r1 and r2 besides match r4, and both r3 and r4 have a practically identical choice. Properly, this firewall can be made more restricted by taking out rule r3. The consistency issue and the flawlessness issue cause firewall messes up. A goof in a firewall recommends that the firewall either perceives two or three hurtful bundles, which as such makes security openings on the firewall, or disposes of several veritable gatherings, which in this manner upsets generally common affiliations. Given the significance of firewalls, such slips up are not tasteful. Tragically, it has been seen that most firewalls on the Web are deficiently organized and have different blunders in their guidelines. The minimization issue causes low firewall execution. Generally, the humbler how much reasons that a firewall has, the quicker the firewall can plan a gathering to the choice of the fundamental rule the group matches. Decreasing the quantity of rules is particularly helpful for the firewalls that utilization TCAM (Ternary Substance Addressable Memory). Such firewalls use $O(n)$ space (where n is the quantity of rules) and consistent time in orchestrating a pack to a choice. Regardless of what the a-list show of such TCAM-based firewalls, TCAM has staggeringly restricted size and consumes through and through more power as the quantity of rules increments. Size cut-off and control use are the two basic issues for TCAM-based firewalls.

REFERENCE

- [1] John Naughton "The evolution of the Internet: from military experiment to General Purpose Technology", *Journal of Cyber Policy*, 1:1, 5-28, DOI:10.1080/23738871.2016.1157619.
- [2] Peter O'Grady "Internet Technologies Overview".
- [3] Jason Edelman "Network Programmability and Automation" 1st edition, O'Reilly.
- [4] James Kurose, "Computer Networking: A Top-Down Approach", 7th edition, Pearson.
- [5] Tanenbaum, "Computer Networks", 5th edition, Pearson Education India.
- [6] Gary A. Donahue, "Network Warrior", 2nd edition, O'Reilly.
- [7] IBM, Documentation, "<https://www.ibm.com/docs/en/aix/7.1?topic=protocol-tcpip-routing>".
- [8] Educba, <https://www.educba.com/what-is-internet-application>.
- [9] <https://www.omniseku.com/basic-networking/difference-between-proprietary-and-standard-protocols.php>
- [10] https://en.wikibooks.org/wiki/Internet_Technologies/Protocols
- [11] http://www.fmc-odeling.org/category/projects/apache/amp/2_3Protocols_Standards.html

- [12] <https://opentextbc.ca/computerstudies/chapter/security-issues-on-the-internet/>
- [13] <https://www.ssl2buy.com/wiki/symmetric-vs-asymmetric-encryption-what-are-differences>
- [14] <https://www.techtarget.com/searchsecurity/definition/encryption>
- [15] <https://www.tutorialspoint.com/what-are-the-types-of-decryption-in-information-security>
- [16] <https://digisign.id/eng-3jenisdigi.html>.
- [17] <https://www.geeksforgeeks.org/authentication-in-computer-network/>
- [18] <https://www.omnisecu.com/basic-networking/internet-intranet-and-extranet.php>.
- [19] Alex X. Liu, “Structured Firewall Design”.