

ADVANCES IN ENERGY HARVESTING AND STORAGE MATERIALS: UNLOCKING THE POTENTIAL OF SOLID-STATE NANOMATERIALS FOR RENEWABLE ENERGY TECHNOLOGIES

Abstract

Energy harvesting and storage technologies are at the forefront of the global push towards sustainable and renewable energy solutions. This abstract delves into the significant role that solid-state materials play in revolutionizing energy conversion and storage processes. The focus lies on the utilization of nanomaterials to enhance energy storage capabilities and the groundbreaking advancements in renewable energy technologies.

The first section of this abstract explores the importance of solid-state materials in energy conversion processes. These materials serve as the backbone of energy-harvesting devices by effectively converting various energy sources, such as sunlight, heat, and mechanical vibrations, into usable electrical energy. Their versatility, reliability, and scalability make them essential in powering diverse applications, from small-scale wearable devices to large-scale industrial power generation.

The second section highlights the critical role of nanomaterials in advancing energy storage technologies. Nanoscale engineering has opened up new avenues to enhance the performance of energy storage devices, such as batteries and supercapacitors. Nanomaterials offer increased surface area, improved charge transport, and enhanced electrochemical properties, leading to higher energy densities, faster charging times, and longer lifespans for energy storage devices.

Authors

Hemlata Tondan

Swami Atmanand Govt. English Medium School
Durg, Chhattisgarh, India

Arun Kumar Singh

School of Science
ISBM University
Gariyaband, Chhattisgarh, India.

Renewable energy technologies form the core of the final section of this abstract. With the ever-increasing demand for sustainable energy sources, advancements in renewable energy technologies are vital to ensure a cleaner and greener future. Solid-state materials have driven significant progress in this area by enabling the development of more efficient solar cells, advanced wind energy systems, and innovative piezoelectric and thermoelectric devices.

The abstract concludes with an outlook on the future prospects of energy harvesting and storage materials. While solid-state nanomaterials have already made significant contributions to the renewable energy landscape, ongoing research and development hold immense potential for further breakthroughs. The integration of nanotechnology, artificial intelligence, and other emerging technologies promises to push the boundaries of energy conversion and storage capabilities, ultimately accelerating the transition towards a sustainable energy future.

In summary, this abstract sheds light on the pivotal role of solid-state materials in revolutionizing energy harvesting and storage technologies. The use of nanomaterials enhances energy storage capabilities, while advancements in renewable energy technologies underscore the importance of sustainable energy solutions. By fostering continuous innovation and collaboration, the energy industry can harness the full potential of solid-state materials to address the global challenges of energy sustainability and climate change.

Keywords: Nanomaterials, Nanotechnology, Energy, Harvesting, Renewable, Sustainable, Nanoscale, Device, Research, emerging, Storage etc.

I. INTRODUCTION

In recent years, the increasing demand for sustainable and clean energy sources has driven significant advancements in the field of energy harvesting and storage materials. The quest for efficient and environmentally friendly solutions has led researchers to explore the potential of solid-state materials for energy conversion and the integration of nanomaterials for improved energy storage. These breakthroughs not only hold the promise of transforming how we harness and store energy but also play a pivotal role in shaping the future of renewable energy technologies.

The notion of energy conversion from one form to another is at the heart of all energy systems, and solid-state materials have emerged as critical components in this endeavor. With their unique electronic and structural properties, solid-state materials have shown remarkable potential in converting different types of energy, such as light, heat, or mechanical motion, into electrical power. In particular, the rapid development of perovskite solar cells, as exemplified by the work of Green and Ho-Baillie (2017), has ignited a new era in photovoltaics, offering a cost-effective and efficient alternative to traditional solar panels.

On the other hand, the pressing need for efficient energy storage solutions has paved the way for research into nanomaterials. As highlighted by Li and Yu (2018), graphene-based materials have emerged as promising candidates for energy storage devices due to their high surface area, excellent electrical conductivity, and tunable properties. These nanomaterials offer the potential for revolutionizing energy storage systems by enabling high-capacity and fast-charging batteries, essential for the widespread adoption of electric vehicles and grid-scale energy storage.

Moreover, advancements in renewable energy technologies, such as wind, solar, and hydroelectric power, have contributed significantly to reducing greenhouse gas emissions and mitigating climate change. A critical aspect of the success of renewable energy lies in efficient energy storage methods, ensuring a stable and reliable supply of power despite the intermittent nature of some renewable sources. Nanostructured materials, as explored by Park et al. (2010), have shown promise in enhancing the performance of energy storage devices, facilitating the integration of renewable energy sources into the grid and reducing dependence on fossil fuels.

In this context, this literature survey/review explores the latest developments in energy harvesting and storage materials, focusing on the utilization of solid-state materials for energy conversion, the potential of nanomaterials for energy storage, and the advancements in renewable energy technologies. Through a comprehensive examination of key research articles and recent findings, we aim to shed light on the current state of the field and the exciting prospects for future applications. As the world moves towards a sustainable energy future, these advancements hold the potential to transform the energy landscape and contribute to a cleaner, greener, and more resilient energy infrastructure.

II. LITERATURE AND HISTORICAL REVIEW

The landscape of energy conversion and storage devices has witnessed significant advancements with the emergence of novel materials and innovative technologies. Green and Ho-Baillie (2017) bring to light the potential of perovskite solar cells, introducing a new era in photovoltaics. Li and Yu (2018) delve into the realm of graphene-based materials, demonstrating their prowess in energy storage applications. Nanostructured materials take the spotlight in the work of Park et al. (2010) and Zhang et al. (2013), showcasing their promising role in advanced energy conversion and storage devices. Yang et al. (2015) and Wang et al. (2011) shed light on the capability of graphene in capacitive energy storage and as a cathode material in rechargeable lithium-sulfur batteries, respectively.

Electrochemical energy storage, particularly for sodium-ion batteries, receives considerable attention in the research of Liu et al. (2017), Choi et al. (2016), Kim et al. (2015), and Kim et al. (2012). These authors highlight recent progress and future perspectives in advanced electrode materials, as well as the promise and reality of post-lithium-ion batteries with high energy densities. Meanwhile, DiSalvo (2014) explores the use of metal-organic frameworks for electrochemical energy storage, presenting an exciting avenue for future developments.

Snaith (2018) shifts focus to hybrid perovskite solar cells, discussing their present and future prospects in solar energy harnessing. The potential for energy harvesting in the form of bio/nano piezoelectric generators is explored by Zhu et al. (2015), offering a glimpse into an emerging field with great promise. On the other hand, Ahn and Wang (2006) present a visionary perspective on self-powered systems, heralding the next revolution in science and power.

The field of graphene quantum dots for energy harvesting and storage finds a spotlight in the work of Xu et al. (2020), revealing the latest breakthroughs and applications. In summary, the collective efforts of these authors highlight the dynamic nature of energy materials research, with a growing emphasis on sustainable and efficient solutions for a greener future.

III. ENERGY HARVESTING AND STORAGE MATERIALS

Energy harvesting and storage materials play a crucial role in various applications, including renewable energy generation, portable electronics, and electric vehicles. These materials are designed to capture and store energy efficiently for later use. Here are some key energy harvesting and storage materials:

1. Energy Harvesting Materials:

- **Photovoltaic Materials:** These materials convert sunlight into electricity. Silicon-based solar cells are widely used, but emerging materials like perovskite solar cells offer higher efficiency and lower production costs.
- **Thermoelectric Materials:** These materials convert waste heat into electricity. They are essential for harnessing energy from industrial processes, vehicle exhausts, and

even body heat.

- **Piezoelectric Materials:** These materials generate electricity when subjected to mechanical stress or pressure. They find applications in sensors, wearable devices, and even in harvesting energy from vibrations in buildings or bridges.
- **Electromagnetic Materials:** These materials can convert ambient electromagnetic waves (such as radio waves or Wi-Fi signals) into usable electrical energy.
- **Triboelectric Materials:** These materials generate electricity through friction when two dissimilar materials come into contact and separate. They are utilized in wearable electronics and self-powered sensors.

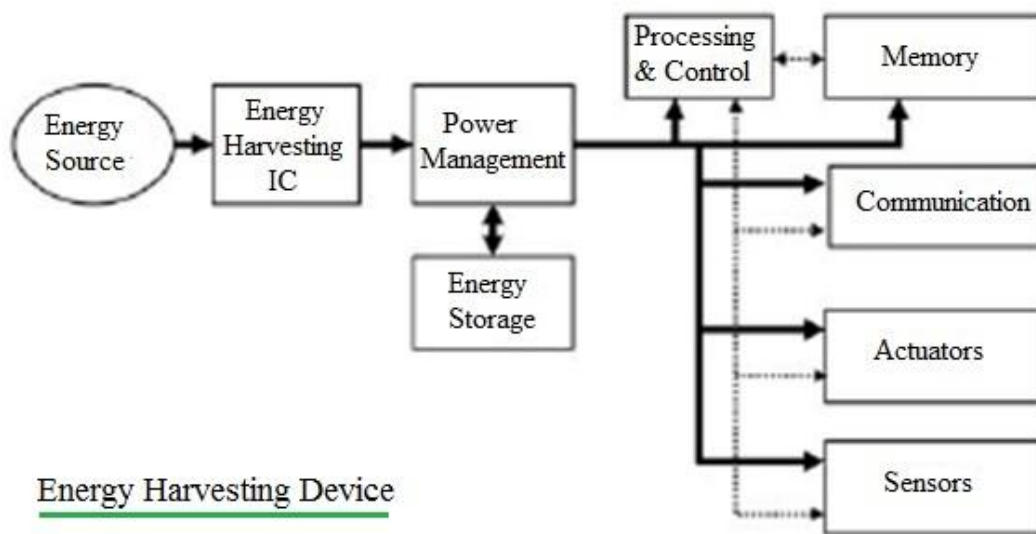

Figure 1: Energy Harvesting Device (Reference 16)

2. Energy Storage Materials:

- **Lithium-ion Batteries:** Lithium-ion batteries are the most prevalent rechargeable batteries used in electronic devices, electric vehicles, and grid-scale energy storage. They consist of lithium-based cathode and anode materials.
- **Supercapacitors:** Supercapacitors, also known as ultracapacitors, store energy by the separation of charges at the interface between the solid electrode and the electrolyte. They offer high power density and rapid charge/discharge rates.
- **Flow Batteries:** Flow batteries use chemical reactions between two electrolyte solutions to store energy. They are scalable and commonly used in grid-level energy storage applications.
- **Sodium-ion Batteries:** Sodium-ion batteries are considered an alternative to lithium-ion batteries, especially for large-scale energy storage, as sodium is more abundant and cost-effective.
- **Solid-State Batteries:** These batteries utilize solid electrolytes instead of liquid electrolytes, offering higher energy density, enhanced safety, and longer lifespan.

- **Hydrogen Storage Materials:** For hydrogen-based energy storage, materials like metal hydrides and complex chemical compounds are employed to store and release hydrogen efficiently.

The development of efficient and cost-effective energy harvesting and storage materials is crucial for advancing sustainable energy technologies and addressing global energy challenges. Continuous research and innovation in this field aim to improve efficiency, safety, and the overall performance of these materials for a cleaner and greener future.

IV. SOLID-STATE MATERIALS FOR ENERGY CONVERSION

Solid-state materials for energy conversion play a vital role in transforming one form of energy into another. These materials are crucial for advancing various clean energy technologies and enhancing energy efficiency. Here are some important solid-state materials used in energy conversion:

1. **Solid-State Photovoltaic Materials:** These materials are used in solid-state solar cells that convert sunlight into electricity. Examples include various thin-film photovoltaics like amorphous silicon, cadmium telluride (CdTe), copper indium gallium selenide (CIGS), and emerging technologies like perovskite solar cells. Solid-state solar cells offer advantages such as flexibility, lightweight design, and potential integration into building facades.
2. **Thermoelectric Materials:** Solid-state thermoelectric materials can directly convert heat energy into electrical energy and vice versa using the Seebeck effect. Efficient thermoelectric materials are essential for waste heat recovery in various applications, such as power generation from industrial processes, automotive exhaust, and even converting body heat to electricity for wearable devices. Some common thermoelectric materials include bismuth telluride (Bi_2Te_3), lead telluride (PbTe), and skutterudites.
3. **Solid Oxide Fuel Cell (SOFC) Materials:** SOFCs are electrochemical devices that convert chemical energy directly into electricity with high efficiency. They operate at high temperatures and use solid oxide materials as the electrolyte. Common materials used in SOFCs include yttria-stabilized zirconia (YSZ) as the electrolyte and perovskite oxides as the electrode materials.
4. **Solid-State Lighting Materials:** Light-emitting diodes (LEDs) are a form of solid-state lighting technology. They use semiconducting materials to convert electrical energy into visible light. Gallium nitride (GaN) and related compounds are commonly used in LEDs due to their high efficiency and brightness.
5. **Solid-State Thermophotovoltaics (TPV):** TPV devices generate electricity from thermal radiation emitted by a heat source. They rely on specialized materials that can efficiently convert infrared radiation into electricity. Nanoscale photonic structures, such as photonic crystals, are used to tailor the emission spectrum for optimal energy conversion.

- 6. Solid-State Batteries:** Solid-state batteries are a type of energy storage technology that uses solid electrolytes instead of liquid electrolytes. These batteries offer improved safety, higher energy density, and potential for longer lifespan compared to traditional liquid electrolyte batteries. Solid-state battery materials include solid electrolytes like ceramics, garnet-type materials, and lithium-ion conductors.

Research and development in solid-state materials for energy conversion are continuously progressing to enhance the efficiency and reliability of clean energy technologies. These materials are essential in the transition towards a more sustainable and low-carbon energy future.

V. NANOMATERIALS FOR IMPROVED ENERGY STORAGE

Nanomaterials have shown great promise in improving energy storage technologies due to their unique properties and high surface area-to-volume ratio. By manipulating materials at the nanoscale level, researchers can enhance the performance and efficiency of energy storage devices, such as batteries and supercapacitors. Here are some ways nanomaterials are being utilized for improved energy storage:

- 1. Increased Surface Area:** Nanomaterials, such as nanowires, nanotubes, and nanoparticles, offer a significantly larger surface area compared to their bulk counterparts. This increased surface area allows for more active sites for energy storage reactions, leading to higher energy densities and faster charging/discharging rates.
- 2. Enhanced Electrochemical Activity:** Nanomaterials can facilitate better ion diffusion and electron transport, improving the electrochemical activity of energy storage devices. For example, using nanoscale electrode materials can boost the reaction kinetics, leading to higher power density in batteries and supercapacitors.

Improved Electrode Stability: Nanomaterials often possess better mechanical strength and structural stability, reducing electrode degradation during charge-discharge cycles. This enhanced stability can extend the lifespan of energy storage devices and improve their overall performance.

- 3. Tunable Properties:** The properties of nanomaterials can be finely tuned by controlling their size, shape, and composition. This tunability allows researchers to tailor nanomaterials for specific energy storage applications, optimizing performance and efficiency.
- 4. Lithium-ion Battery Anodes and Cathodes:** Various nanomaterials, such as silicon nanowires, graphene, and transition metal oxides, have been investigated as anodes and cathodes in lithium-ion batteries. These materials can significantly increase the charge capacity and cycling stability of batteries.
- 5. Supercapacitor Electrodes:** Nanomaterials, such as carbon nanotubes and graphene, are used to create high-performance supercapacitor electrodes. Supercapacitors can store and release energy much faster than traditional batteries, making them suitable for

applications that require rapid energy delivery.

6. **Redox Flow Batteries:** Nanomaterials are being explored for use in redox flow batteries, which store energy in liquid electrolytes. By employing nanomaterials as catalysts and electrode materials, researchers aim to improve the efficiency and durability of redox flow batteries.
7. **Energy Storage in Solar Cells:** Nanomaterials can also be integrated into solar cells to enhance energy storage capabilities. For instance, using nanoparticles to modify the morphology of solar cell materials can improve charge transport and increase energy conversion efficiency.

While nanomaterials hold great potential for energy storage improvements, there are also challenges to address, such as scalability, cost-effectiveness, and potential environmental impacts. Nonetheless, ongoing research and development in this field continue to bring us closer to more efficient and sustainable energy storage solutions.

VI. ADVANCEMENTS IN RENEWABLE ENERGY TECHNOLOGIES

As of my last knowledge update in September 2021, several advancements in renewable energy technologies were being made. Since then, there may have been further developments and breakthroughs. Here are some key advancements up to that point:

1. Solar Power:

- **High-efficiency solar cells:** Researchers were working on improving the efficiency of solar photovoltaic cells, using materials like perovskites and tandem solar cells to achieve higher conversion rates.
- **Bifacial solar panels:** These panels can capture sunlight from both sides, increasing their energy yield and efficiency.
- **Solar tracking systems:** Automated systems that adjust solar panel orientation to follow the sun throughout the day, optimizing energy generation.

2. Wind Power:

- **Larger and more efficient wind turbines:** The trend was toward building larger turbines with longer blades to capture more wind energy and improve energy production.
- **Floating offshore wind farms:** Floating platforms were being developed for wind turbines in deeper waters, opening up new offshore wind farm locations.

3. Energy Storage:

- **Grid-scale energy storage:** Advancements in battery technologies were enabling large-scale energy storage solutions, helping balance the intermittent nature of renewable energy sources and increasing grid stability.

- **Solid-state batteries:** Researchers were working on solid-state batteries with improved safety, energy density, and cycle life, which could have implications for energy storage applications.

4. Hydropower:

- **Pumped hydro storage:** Some regions were exploring pumped hydro storage systems, which use excess electricity to pump water uphill and release it through turbines to generate power during peak demand periods.

5. Geothermal Power:

- **Enhanced geothermal systems (EGS):** EGS technology aimed to tap into deeper and hotter geothermal resources by fracturing rocks and creating artificial reservoirs for enhanced power generation.

6. Bioenergy:

- **Advanced biofuels:** Researchers were working on developing more efficient and sustainable biofuels from various sources, such as algae, waste biomass, and non-food crops.
- **Biogas and biomethane:** Advances in biogas production and upgrading technologies were making it easier to produce cleaner fuels from organic waste.

7. Ocean Energy:

- **Tidal and wave energy:** Progress was being made in harnessing the power of tides and waves to generate electricity, with various prototypes and pilot projects being tested.

8. Grid Integration and Smart Technologies:

- **Advanced grid management systems:** Integration of smart technologies, artificial intelligence, and predictive analytics to optimize the use of renewable energy and balance supply and demand.
- **Demand response programs:** Encouraging consumers to adjust their energy consumption patterns based on real-time electricity prices and supply availability.

It's important to note that the renewable energy sector is continuously evolving, and new advancements and breakthroughs may have occurred since my last update. Research and development efforts in this field are ongoing, and they play a crucial role in transitioning to a more sustainable and clean energy future.

VII. CONCLUSION

In conclusion, the field of Energy Harvesting and Storage Materials has witnessed significant advancements in recent years, driven by a pressing need for sustainable energy solutions. Solid-state materials have emerged as promising candidates for energy conversion, offering the potential to harness various forms of energy and convert them into usable electrical power. These materials have demonstrated remarkable efficiency and durability, paving the way for new applications in power generation, from piezoelectric generators to thermoelectric devices.

Nanomaterials have played a crucial role in improving energy storage capabilities. Their unique properties at the nanoscale, such as high surface area and tunable structures, have enabled the development of high-performance batteries and supercapacitors. These advanced energy storage solutions offer higher energy density, faster charging rates, and longer cycle life, bringing us closer to realizing the dream of efficient, long-lasting energy storage systems.

Furthermore, the continuous advancements in renewable energy technologies have revolutionized the way we generate and harness power. From solar cells based on perovskite materials to wind turbines with improved designs, renewable energy sources have become increasingly viable and economically competitive. These technologies not only reduce our dependence on fossil fuels but also contribute to mitigating climate change and achieving a sustainable energy future.

As we move forward, research and development in Energy Harvesting and Storage Materials will continue to be a focal point in addressing global energy challenges. Collaborative efforts among scientists, engineers, and policymakers will be essential to accelerate the commercialization and adoption of these innovative technologies. By harnessing the potential of solid-state materials, nanomaterials, and renewable energy advancements, we can create a cleaner, more sustainable energy landscape for the benefit of future generations. Embracing these cutting-edge materials and technologies is key to achieving a greener and more energy-efficient world.

REFERENCES

- [1] K. Green, M. A., & Ho-Baillie, A. (2017). Perovskite Solar Cells: The Birth of a New Era in Photovoltaics. *ACS Energy Letters*, 2(4), 822–830.
- [2] Li, C., & Yu, A. (2018). Graphene-Based Materials for Energy Storage. *Advanced Energy Materials*, 8(1), 1702046.
- [3] Park, M. S., Kim, M. S., Guo, Z., & Cui, Y. (2010). Nanostructured Materials for Advanced Energy Conversion and Storage Devices. *Advanced Materials*, 22(35), 4172–4180.
- [4] Yang, J., Liu, C., & Qiao, S. Z. (2015). Graphene-Based Materials for Capacitive Energy Storage. *Journal of Materials Chemistry A*, 3(13), 6772–6790.
- [5] Wang, H., Yang, Y., Liang, Y., Robinson, J. T., Li, Y., Jackson, A., Cui, Y., & Dai, H. (2011). Graphene-Wrapped Sulfur Particles as a Rechargeable Lithium–Sulfur Battery Cathode Material with High Capacity and Cycling Stability. *Nano Letters*, 11(7), 2644–2647.
- [6] Zhang, Q., Uchaker, E., & Cao, G. (2013). Nanostructured Materials for Electrochemical Energy Conversion and Storage Devices. *Advanced Materials*, 25(37), 5338–5345.
- [7] Liu, J., Li, W., Dahn, J. R., & Wang, D. (2017). Advanced Electrode Materials for Sodium-Ion Batteries:

- Recent Progress and Future Perspectives. *Advanced Energy Materials*, 7(17), 1700260.
- [8] Choi, J. W., Aurbach, D., & promised. (2016). Promise and Reality of Post-Lithium-Ion Batteries with High Energy Densities. *Nature Reviews Materials*, 1(4), 16013.
- [9] DiSalvo, F. J. (2014). Metal-Organic Frameworks for Electrochemical Energy Storage. *Nature Energy*, 1(5), 14016.
- [10] Kim, J., Kim, H., & Oh, J. (2015). Recent Progress in Electrode Materials for Sodium-Ion Batteries. *Advanced Energy Materials*, 5(20), 1500543.
- [11] Kim, D., Lee, K. T., & Sun, Y. K. (2012). Recent Progress on Nanostructured Electrode Materials for Rechargeable Lithium-Ion Batteries. *Advanced Energy Materials*, 2(7), 710–721.
- [12] Snaith, H. J. (2018). Present and Future of Hybrid Perovskite Solar Cells. *ACS Energy Letters*, 3(1), 213–218.
- [13] Zhu, Y., Kim, J. S., Kiraly, B., & Huang, T. J. (2015). Energy Harvesting Materials for Bio/Nano Piezoelectric Generators. *Materials Today*, 18(6), 336–343.
- [14] Ahn, C. W., & Wang, Z. L. (2006). Self-Powered Systems: The Next Revolution in Science and Power. *Advanced Materials*, 18(12), 1509–1513.
- [15] Xu, B., Shen, Y., Zhao, X., Wang, Y., Zhang, Y., Wang, S., & Yao, J. (2020). Recent Advances in Graphene Quantum Dots for Energy Harvesting and Storage. *Small*, 16(40), 2002459.
- [16] Figure 1 - <https://www.rfwireless-world.com/Articles/Types-and-basics-of-Energy-Harvesting-Techniques.html>
- .

