

DEVELOPMENT OF A SMART RAILWAY PLATFORM SYSTEM

Abstract

Public safety at railway stations is a critical issue, as there is a risk of accidents involving trains, especially in crowded areas such as overhead bridges and elevators. This paper presents the development of a Smart Railway Platform (SRP) system, which is an automation technique that utilizes technology to improve safety and accessibility on railway platforms. The developed SRP system is tested in a real-world setting, and is found to be effective in preventing accidents and improving the safety on the railway platform. It has the potential to improve the accessibility of the disabled individuals. The paper also highlights the challenges and limitations of the SRP systems, and it explores the future of this technology.

Keywords: smart railway platform system, arduino uno, ultrasonic sensor, servo motor, IC 555 timer

Authors

Jatismar Saha

Department of Electronics & Communication Engineering
School of Technology
North-Easter Hill University
Shillong, Meghalaya, India.

Rohan Choudhuri

Department of Electronics & Communication Engineering,
School of Technology
North-Eastern Hill University
Shillong, Meghalaya, India.

Dipankar Kalita

Department of Electronics & Communication Engineering
School of Technology
North-Eastern Hill University
Shillong, Meghalaya, India.

Jaydeep Swarnakar

Department of Electronics & Communication Engineering
School of Technology
North-Eastern Hill University
Shillong, Meghalaya, India.

I. INTRODUCTION

Railway platforms are critical transportation infrastructure that facilitates the movement of millions of people around the world every day. However, railway platforms can also be dangerous places, as they are often crowded and there is a risk of accidents involving trains. In recent years, there has been a growing focus on improving safety and accessibility on railway platforms. One promising approach is the use of Smart Railway Platform (SRP) systems. The SRP systems are the automation techniques that utilize technology to improve safety and accessibility on railway platforms. These systems typically consist of an ultrasonic sensor, a motor, and a relay circuit board. The ultrasonic sensor detects the presence of trains and activates the motor, which then slides the platform away from the tracks. This prevents the passengers and the railway staff from accidentally crossing the tracks while a train is approaching. In addition to improving safety, the SRP systems can also improve the accessibility of the disabled individuals. Crossing the railway tracks can be challenging for people with disabilities as they may have difficulty walking or maneuvering in crowded spaces. However, the SRP systems allow disabled individuals to cross the tracks safely and independently. This can greatly improve their mobility and independence, and it can also make the railway platforms more inclusive for all users. As public safety continues to be a crucial aspect of transportation infrastructure, further advancements in automation technology can lead to the development of new-generation SRP systems. These systems would integrate advanced safety features, improve accessibility for diverse user groups, and enhance the overall public confidence in railway systems.

II. LITERATURE REVIEW

1. Past Research Work: In this subsection, an attempt has been made to review some of the past work done in the area of SRP system. Mahdi and Al-Zuhairi [1] focused on automatic railway gate and crossing control systems based on sensors and a microcontroller. The author discussed the severity and death rates of rail traffic accidents and emphasized the need for improving safety measures. The study highlighted the issue of unmanned railway crossings and the accidents that occur due to the absence of gate keepers to manage the railway gates when a train approaches. Anil et al. [2] presented an advanced railway accident prevention system that utilized sensor networks. The study emphasized the need for effective control systems in high-density rail traffic areas. The proposed system used IR sensors, fire sensors, Zigbee, and embedded systems to prevent accidents. It focused on detecting train arrival and bringing the railway to a stop. Flood et al. [3] conducted a study in 2018 to investigate the series of injuries due to transport accidents involving railway trains from 2001-2002 to 2005-2006 in Australia. The study utilized data from the National Coroners Information System (NCIS) to analyze injury severity, demographics, location and time of occurrence, and primary causes of injuries. The study found that there were 3,098 injuries during the study period, with the majority being minor injuries, and males and 15-24-year-olds being the most commonly injured. The most common causes of injury were collisions with objects, slips, and falls, with the most common location of accidents being within the train or station. The study's findings could be used to develop interventions to improve railway transport safety and reduce the occurrence of permanent disability injuries.

Mansingh et al. [4] proposed an automated system for unmanned railway level crossings, using sensors to detect the presence of a train and activate the crossing gate and track signals. Tests showed accurate and timely performance in various weather conditions. The system offers a reliable and efficient solution, improving safety in railway operations, but requires further research to evaluate long-term effectiveness. Prabhavathi et al. [5] reported a system for safely crossing railway tracks between platforms. The authors proposed a solution using infrared sensors and a microcontroller that can detect the presence of trains and prevent pedestrian crossings when necessary. The system can improve safety and convenience for pedestrians, but further research is needed to evaluate its effectiveness in real-world settings. Kottalil et al. [6] have studied the design and implementation of a system that uses sensors to automate the opening and closing of railway gates. The paper discussed the various components of the system and how they work together to enhance railway safety. The authors provided an evaluation of the system's effectiveness in reducing accidents at railway crossings. Krishna et al. [7] have discussed a study on the design and implementation of a system that uses a microcontroller to automate the opening and closing of railway gates. The authors discussed the various components of the system, including sensors and a microcontroller, and how they worked together to enhance the railway safety. The paper provided an evaluation of the system's performance in terms of accuracy and reliability.

An automated railway platform safety system with real-time monitoring and alerting was studied by Sharma et al. [8]. The study addressed the critical need for the enhancing railway platform safety through automation. By integrating real-time monitoring and alerting capabilities, the system aims to detect potential hazards promptly and issue alerts to relevant personnel and commuters. The research emphasizes the significance of advanced technologies and methodologies in streamlining railway platform operations and reducing accidents. This study contributes to the field of computer and communication engineering by presenting an innovative approach to improve passenger safety and optimize platform management. Patel et al. [9] presented reviewed literature on smart railway platform management system using the Internet of Things (IoT). The study emphasized the integration of IoT technology to optimize railway platform management. By utilizing IoT-enabled sensors and devices, the system can collect real-time data on platform conditions, train arrivals, and passenger movements. This data facilitates efficient crowd management, improved train scheduling, and enhanced passenger experience. The research contributes to the field of computer and communication engineering by proposing an innovative solution to modernize railway platforms and improve overall efficiency and safety. Further validation and real-world implementation are necessary to assess the system's practicality and effectiveness in actual railway settings. Dey et al. [10] research focused on the design and development of an automatic railway platform gate control system with train arrival detection. They studied the integration of train arrival detection mechanisms to automate platform gate operations, streamlining passenger boarding and alighting processes. By implementing this system, railway platforms can enhance safety, reduce accidents, and improve overall efficiency. The research contributes to the field of engineering by presenting a practical solution for modernizing railway platforms and optimizing passenger flow. Kumar et al. [11] explored the radio frequency identification (RFID)-based smart railway platform for passenger safety and security. The study highlighted the significance of RFID technology in real-time monitoring of passenger movements and train positions. By efficiently managing crowd flow and restricting access

to authorized personnel, the system aimed to enhance the platform safety and security. The research's valuable contribution lies in its practical approach to modernizing railway platforms and improving the overall passenger experience. Further validation and implementation in real-world scenarios would be necessary to ascertain the system's effectiveness and potential challenges.

Singh et al. [12] presented an automatic railway platform management system using wireless sensor networks (WSNs). The study focused on the application of WSNs to efficiently monitor railway platforms, collecting real-time data on passenger density, train arrivals, and environmental conditions. The integration of WSNs allows seamless communication and data exchange between sensors and a centralized control system, enabling dynamic platform management. This research contributes to the field of computer applications by offering a scalable and automated solution for optimizing platform operations, enhancing passenger safety, and streamlining railway transportation. However, further validation and real-world implementation are necessary to assess the system's practicality and effectiveness in real railway environments. Mohan et al. [13] presented a machine vision-based passenger safety and crowd detection system for railway platforms. The study highlighted the utilization of machine vision technology to ensure passenger safety and detect crowd density on railway platforms. By employing cameras and image processing algorithms, the system can monitor platform occupancy and detect potential safety hazards in real-time. This research contributes to the field of pure and applied mathematics by offering an innovative solution for enhancing railway platform safety and improving crowd management. However, further validation and real-world implementation are necessary to assess the system's effectiveness in practical railway settings.

An intelligent railway platform with hazard detection and alerting system was studied by Jain et al. [14]. This work focused on developing an intelligent platform that integrates hazard detection mechanisms and alerting systems. By utilizing advanced sensors and algorithms, the system can identify potential dangers on railway platforms and promptly issue warnings to relevant authorities and passengers. This research contributes to the field of engineering research and technology by proposing an innovative solution to enhance railway platform safety and response efficiency. However, further validation and real-world implementation are necessary to assess the system's practicality and effectiveness in real railway environments. Reddy et al. [15] presented an IoT-based smart railway platform security and management system. The study focuses on utilizing the IoT technology to enhance platform security and management. By integrating IoT-enabled sensors and devices, the system can monitor various aspects of railway platforms, including security threats and passenger flow. This research contributes to the field of science, engineering, and technology by proposing a scalable and efficient solution to modernize railway platforms and improve overall security and passenger experience. Further validation and real-world implementation would be essential to assess the system's practicality and effectiveness in real railway settings. Saravanan et al. [16] studied a novel approach for Railway Platform Passenger Tracking and Alerting System using GSM and GPS. They focused on a unique system that employed GSM and GPS technologies for passenger tracking on railway platforms. By integrating these technologies, the system can monitor passenger movements and provide real-time alerts for train arrivals and departures. This research contributes to the field of engineering and technology by offering an innovative solution to enhance platform management and passenger experience. However,

further validation and real-world implementation are necessary to assess the system's practicality and effectiveness in actual railway environments.

Venkatesh et al. [17] investigated a real-time smart railway platform management system using Arduino and GSM. The study introduced an intelligent platform management system that utilizes Arduino and GSM technologies. By integrating these components, the system can monitor platform conditions in real-time and communicate crucial information to railway personnel and commuters. This research contributes to the field of emerging technology and advanced engineering by proposing an efficient and automated solution to optimize platform operations and enhance passenger safety. However, further validation and real-world implementation are essential to evaluate the system's practicality and effectiveness in actual railway settings. [18] Sharma et al. [18] studied an IoT-based Smart Railway Platform Surveillance and Alerting System. They focused on utilizing the Internet of Things (IoT) technology to enhance railway platform surveillance and safety. By integrating IoT-enabled sensors and devices, the system continuously monitors platform conditions, passenger movements, and potential hazards. Real-time data analysis enables prompt alerts and notifications to railway personnel and commuters, improving overall platform management and passenger safety. This research contributes to the field of computer science and information technologies by offering an innovative solution to modernize railway platforms and optimize safety measures. Further validation and real-world implementation would be essential to assess the system's effectiveness in practical railway settings.

The crowd management and passenger safety in railway platforms using Wireless Sensor Networks (WSNs) was investigated by Kumar et al. [19]. The study focused on the application of WSNs to efficiently manage crowds and to enhance the passenger safety on railway platforms. By utilizing advanced sensors, the system collected the real-time data on passenger density and movement, thereby enabling the dynamic crowd management. This research proposed a scalable and automated solution to optimize platform operations, reduce congestion, and ensure passenger well-being. However, further validation and real-world implementation are necessary to assess the system's practicality and effectiveness in real railway environments. Raman et al. [20] presented an AI-based real-time platform safety system for Indian railways. They used AI technology to enhance the platform safety in the context of Indian railways. By integrating AI algorithms, the system can analyze real-time data from sensors and cameras, identifying potential safety risks and issuing immediate alerts. This research proposed an intelligent solution to improve railway platform safety and mitigate accidents. Further validation and real-world implementation would be necessary to assess the system's practicality and effectiveness in the unique context of Indian railways. Arora et al. [21] present a literature review on a vision-based railway platform surveillance and management system where the focus was on the use of computer vision technology to enhance the railway platform surveillance and management. By employing cameras and image processing algorithms, the system can monitor platform conditions, passenger movements, and potential hazards in real-time. This research contributes to the field of control, automation, and electrical systems by proposing an innovative and efficient solution to modernize railway platforms and improve overall safety and management. Further validation and real-world implementation are necessary to assess the system's practicality and effectiveness in actual railway environments.

- 2. Research Gaps and Present Objective:** Despite having some amount of development in the area of SRP system, there are several drawbacks such as (a) limitations in railway safety research, (b) obsolete Indian railway structures lack device- management, (c) inadequate research on Indian level crossings, (d) implementing automated level crossings presents difficulties, and (e) inadequate comparison of railway technologies. In view of this, the present paper aims to (i) analyze the technical aspects of the SRP system, including ultrasonic sensors and sliding platforms, to enhance railway platform safety and accessibility, (ii) evaluate how the SRP system detects trains, activates safety measures, and minimizes accidents, enhancing public safety for passengers and staff, and (iii) to assess how the SRP system can transform railway platforms into safer and more accessible spaces, inspiring future advancements in transportation infrastructure.

III. METHODOLOGY

The construction of the SRP system involves assembling the hardware, scripting the Arduino program, conducting experiments, and studying the data. The system is then ready for its use to detect objects and provide audio feedback. The construction of the SRP system involves the following steps:

- 1. Organizing the hardware:** This includes attaching the Arduino Uno to other components, such as the ultrasonic sensor. The hardware is then connected to a power supply and a computer.
- 2. Scripting the Arduino program:** This code is responsible for generating ultrasonic pulses, detecting echo signals, and determining the object's distance. The code is written in the Arduino programming language.
- 3. Conducting Experiments:** A few tests are conducted to see how well the audio feedback works and how accurate the ultrasonic sensor is. The tests are conducted in a variety of environments, including different distances and different types of objects.
- 4. Studying the Data:** The data gathered from the experiments is studied to evaluate the accuracy of the ultrasonic sensor and the efficiency of the audio feedback. The data is also used to improve the performance of the SRP system.

The various components used in the developed SRP system include (a) Arduino uno, (b) ultrasonic sensor module, (c) jumper wire, (d) battery, (e) servo motor and (f) LED. The flowchart of the developed SRP system is shown in Figure 1. The circuit diagram of the set-up is shown in Figure 2. The ultrasonic sensor is connected to the Arduino Uno through the digital pin 13. The slide switch is connected to the Arduino Uno through the digital pin 10. The DC socket and pin with battery are connected to the Arduino Uno through the digital pin 5. The resistor and LED are connected to the Arduino Uno through the digital pin 3. The DC battery 9V is connected to the DC socket and pin with battery. The female header is connected to the Arduino Uno. The circuit includes a receiver and a transmitter. If an impediment is present when the transmitter emits a signal, the signal is reflected towards the receiver and recognized. The ultrasonic sensor can only detect distances ranging from 2 cm to 4 cm. When the sensor detects a train approaching the platform, the servo motor becomes aware of the impending train through the sensor, and the barrier is removed. The servo motor is activated when the sensor motor senses an

oncoming train at 90° rotation.

The data collected from the experiments will be analyzed using the Arduino IDE. The Arduino IDE is a software application that allows users to write and run Arduino code. The data analysis will include the following steps:

- Import the data into the Arduino IDE.
- Plot the data.
- Calculate the accuracy of the ultrasonic sensor.
- Evaluate the effectiveness of the auditory feedback.

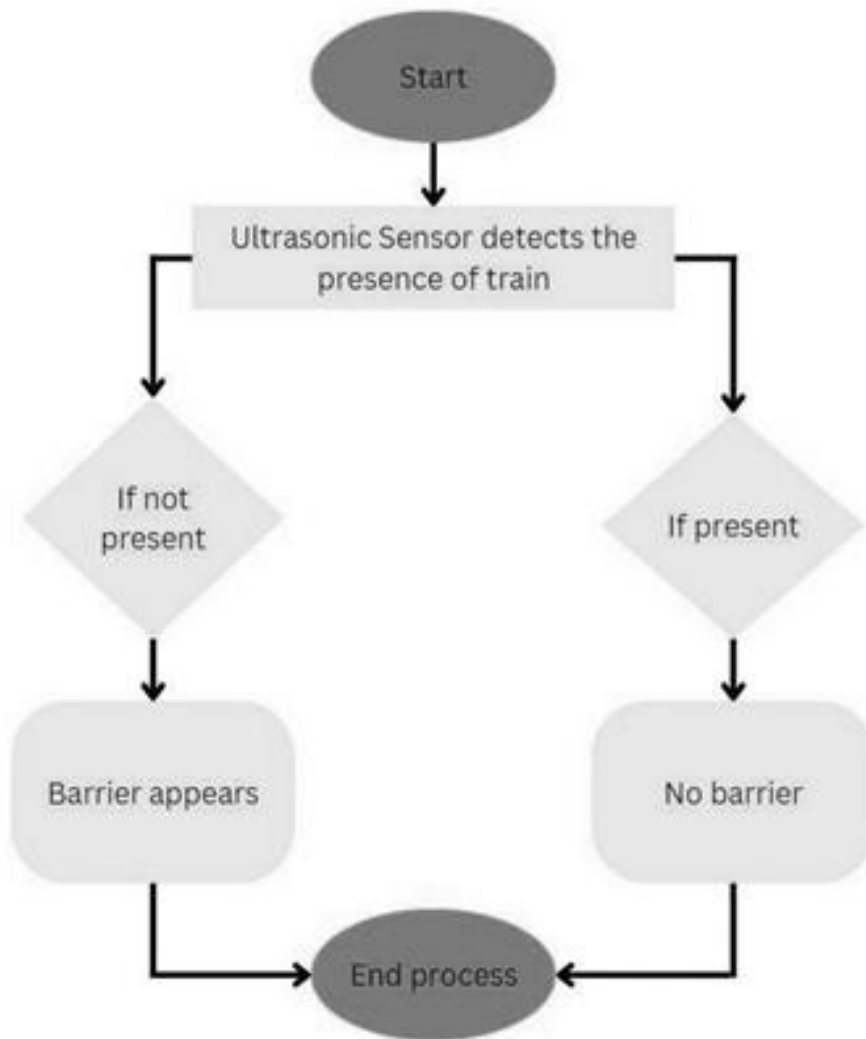

Figure 1: Flow Chart of the Developed SRP System

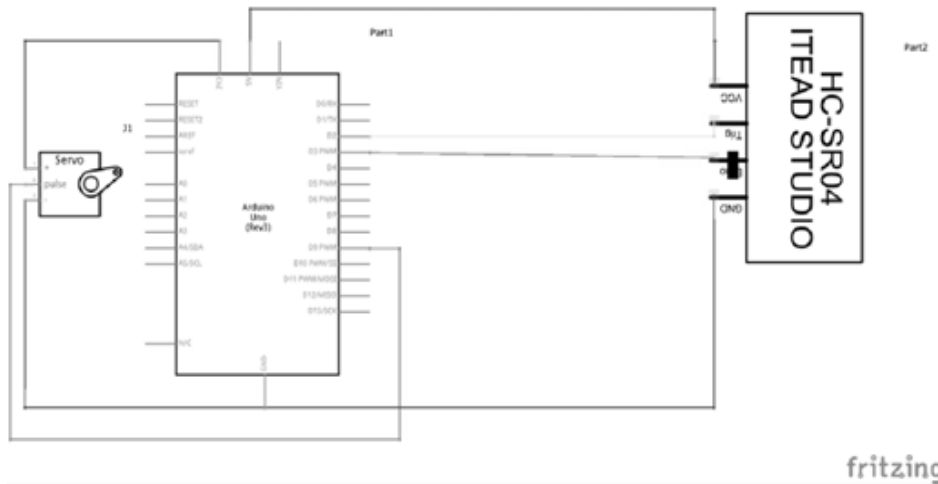

Figure 2: Circuit Diagram of SRP system

The automatic platform light system is a simple and effective way to control platform lights on a railway platform. The system can be easily installed and maintained. The system can also be adjusted to meet the specific needs of the railway platform. An automatic platform light for a railway platform is a system that uses a light-dependent resistor (LDR) sensor and an IC 555 timer to turn on and off the platform lights based on the amount of light present. The LDR sensor is a resistor whose resistance decreases as the amount of light hitting it increases. When the LDR sensor is in darkness, its resistance is high, which prevents the IC 555 timer from triggering. This keeps the platform lights turned off. When the LDR sensor is exposed to light, its resistance decreases, which triggers the IC 555 timer. This turns on the platform lights. The circuit for an automatic platform light using an LDR sensor and an IC 555 timer is relatively simple as shown in Figure 3. The LDR sensor is connected to the trigger pin of the IC 555 timer. The output pin of the IC 555 timer is connected to the platform lights. The IC 555 timer is also connected to a power supply. The developed model of the SRP system is shown in Figure 4.

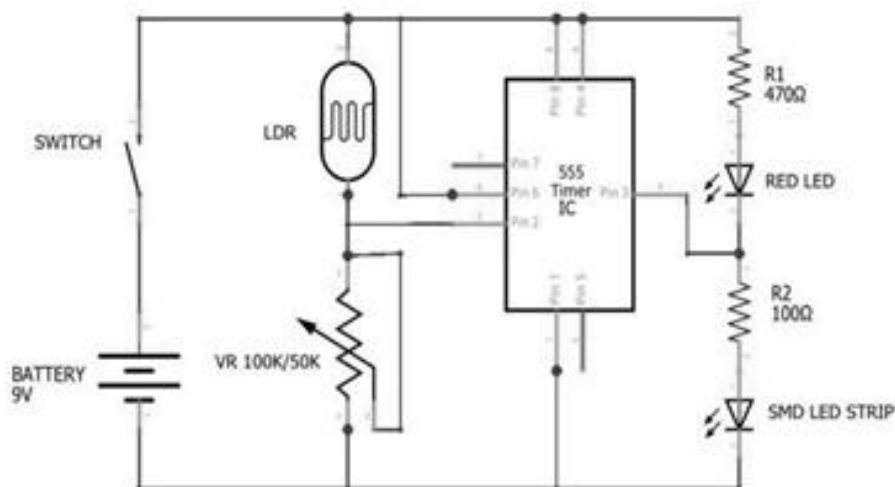

Figure 3: Circuit Diagram of automated Railway Platform Lights

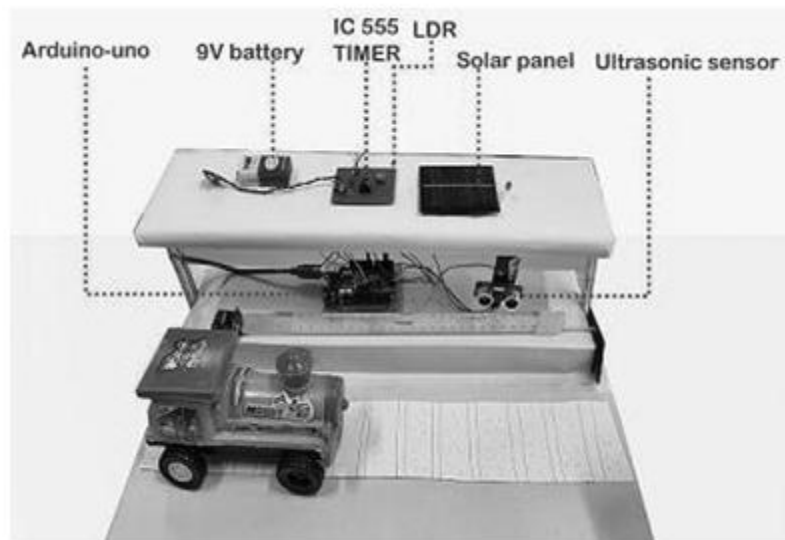

Figure 4: Developed model of the SRP system

IV. CONCLUSION AND FUTURE SCOPE

The SRP system represents a groundbreaking approach to improving public safety and accessibility in railway stations. Through the incorporation of automation technology, the system effectively mitigates risks associated with crowded areas, such as overhead bridges and elevators. Furthermore, the SRP system provides a practical solution for disabled individuals, enabling them to cross railway tracks independently and safely. The active involvement of station masters ensures the proper functioning and safety of the system. The SRP system has the potential to revolutionize railway platforms, fostering a safer and more inclusive environment for all passengers. As technology continues to evolve, further advancements in automation can pave the way for a future generation of railway platforms that prioritize public safety and accessibility. In this paper, an attempt has been made to analyze the technical aspects of an SRP system considering the railway platform safety and accessibility. The developed SRP system is tested for its evaluation in detecting trains so that it minimizes the accidents and enhances the public safety. It also assessed on how the SRP system can transform railway platforms into safer and more accessible spaces, inspiring future advancements in transportation infrastructure.

There are several drawbacks in the present developed SRP. In future, the following work can be pursued to improve the system. The SRP system is designed to minimize the risks associated with crowded overhead bridges, elevators, and other areas of railway stations. The use of automation technology, such as IR sensors, motors, and relay circuit boards, ensures that the system is reliable and efficient in preventing accidents on railway tracks. The sliding platform in the SRP system is especially helpful for disabled persons, who may find it challenging to cross railway tracks without assistance. With the sliding platform, they can cross the tracks independently and safely, promoting their independence and freedom. The SRP system can save time for commuters who need to cross the railway tracks. Instead of waiting for a train to pass and then crossing the tracks, they can use the sliding platform to cross the tracks quickly and safely. The cost of implementing the SRP system is relatively low compared to the potential benefits of improving public safety and accessibility.

Additionally, the system's maintenance costs are minimal as it uses simple, reliable automation technology. The SRP system can help to reduce congestion on railway platforms, as commuters can cross the tracks quickly and efficiently without causing delays. The systems could be integrated with artificial intelligence (AI) to improve their safety and efficiency. For example, AI could be used to identify potential hazards, such as people or objects on the tracks, and to take corrective action. The SRP systems could use new technologies, such as 5G and blockchain, to improve their performance. For example, 5G could be used to provide real-time data to SRP systems, while the blockchain could be used to secure the data and prevent fraud.

REFERENCES

- [1] Mahdi A S and Al-Zuhairi, (2013), Automatic Railway Gate and Crossing Control based Sensors and Microcontroller, *International Journal of Computer Trends and Technology*, Vol. 4, No. 7, pp. 2135 – 2140.
- [2] Anil M D, Sangeetha S, Divya B, Niranjana B, and Shruthi K S, (2014), Advanced Railway Accident Prevention System Using Sensor Networks, *International Journal of Advanced Research in Computers And Communication Engineering*, Vol. 3, No. 5, pp. 6730-6732.
- [3] Flood L, Barry J G, and Harrison J E, (2018), Series of Injury Due To Transport Accidents Involving Railway Train in Australia, *Injury Research Statistics Series*, Number 37, ISSN-1444-3791.
- [4] Mansingh B B, Selvakumar K S, Vignesh Kumar S R, (2015), Automated unmanned Railway Level Crossing System, *IEEE 9th International Conference on Intelligent Systems and Control*, Coimbatore, India, 2015, pp. 1-4, doi: 10.1109/ISCO.2015.7282344.
- [5] Prabhavathi G, Sanjana B, Dhivya S P, (2014), Railway Track Pedestrian Crossing Between Platforms” *IOSR Journal of Electronics and Communication Engineering*, Vol. 9, No. 2, pp. 87-91.
- [6] Kottalil A M, Abhijith S, Ajmal M, Abhilash L J, and Babu A, (2014), Automatic Railway Gate Control System, Vol. 3, February 2014.
- [7] Krishna, S Yadav, and Nidhi, (2013), Automatic Railway Gate Control Using Microcontroller, *Oriental Journal of Computer Science and Technology*, Vol. 6, No. 4, pp. 435-440.
- [8] Sharma A, Sood P, and Singh R, (2016), Automated Railway Platform Safety System with Real-Time Monitoring and Alerting, *International Journal of Innovative Research in Computer and Communication Engineering*, Vol. 4, No. 6, pp. 5948-5953.
- [9] Patel N, Reddy P, Reddy M, and Kishan A, (2015), Smart Railway Platform Management System using Internet of Things (IoT), *International Journal of Innovative Research in Computer and Communication Engineering*, Vol. 3, No. 4, pp. 3124-3129.
- [10] Dey P, Aich S, Pal A, and Mitra P, (2017), Design and Development of an Automatic Railway Platform Gate Control System with Train Arrival Detection, *International Journal of Engineering Research & Technology*, Vol. 6, No. 9, pp. 69-72.
- [11] Kumar S, Ahuja S, Kumar A, and Raj P, (2018), RFID-based Smart Railway Platform for Passenger Safety and Security, *International Journal of Innovative Research in Science, Engineering and Technology*, Vol. 7, No. 5, pp. 4897-4902.
- [12] Singh M, Verma P, and Patel A, (2016), Automatic Railway Platform Management System using Wireless Sensor Networks, *International Journal of Computer Applications*, Vol. 148, No. 15, pp. 1-6.
- [13] Mohan S, Ganesan S, and Kumar S, (2019), Machine Vision-based Passenger Safety and Crowd Detection System for Railway Platforms, *International Journal of Pure and Applied Mathematics*, Vol. 120, No. 2, pp. 2153-2162.
- [14] Jain P, Arora R, and Agarwal A, (2018), Intelligent Railway Platform with Hazard Detection and Alerting System, *International Journal of Engineering Research & Technology*, Vol. 7, No. 4, pp. 85-89.
- [15] Reddy S, Varma S, Reddy P, and Goud K, (2017), IoT-based Smart Railway Platform Security and Management System, *International Journal of Innovative Research in Science, Engineering and Technology*, Vol. 6, No. 12, pp. 26352-26358.
- [16] Saravanan T, Rajan C, and Nanthini A, (2018), A Novel Approach for Railway Platform Passenger Tracking and Alerting System using GSM and GPS, *International Journal of Engineering & Technology*, Vol. 7, No. 2.2, pp. 362-366.
- [17] Venkatesh K, Balasubramanian K, and Vigneshwaran S, (2017), Real-Time Smart Railway Platform Management System using Arduino and GSM, *International Journal of Emerging Technology and*

- Advanced Engineering, Vol. 7, No. 8, pp. 103-108.
- [18] Sharma R, Agarwal S, and Gupta A, (2019), IoT-based Smart Railway Platform Surveillance and Alerting System, International Journal of Computer Science and Information Technologies, Vol. 10, No. 3, pp. 1990-1995.
- [19] Kumar V, Rajput N, and Verma R, (2016), Crowd Management and Passenger Safety in Railway Platforms using Wireless Sensor Networks, International Journal of Computer Applications, Vol. 136, No. 13, pp. 1-6.
- [20] Raman P, Samanta P, and Sharma A, (2021), An AI-based Real-Time Platform Safety System for Indian Railways, International Journal of Innovative Technology and Exploring Engineering, Vol. 10, No. 4, pp. 3081-3086.
- [21] Arora V, Singh R, and Kumar A, (2018), Vision-based Railway Platform Surveillance and Management System, Journal of Control, Automation and Electrical Systems, Vol. 29, No. 1, pp. 71-79.