

IOT BASED AIR POLLUTION DETECTOR

Abstract

The escalation of regulatory efforts pertaining to air pollution levels is seeing significant growth, emerging as a crucial responsibility for governments in developing nations, with particular emphasis on India. It is important for individuals to possess knowledge on the extent of pollution in their immediate environment and to actively engage in efforts to combat it. Various factors contribute to air pollution, including weather conditions, traffic patterns, the combustion of fossil fuels, and industrial emissions, particularly those from power plants. Among the several constituents of atmospheric composition that contribute to the assessment of air quality, particulate matter has significant importance. When the concentration of this substance is elevated in the atmosphere, it poses significant health risks to individuals. Therefore, it is essential to maintain regular monitoring of its atmospheric concentration in order to exercise control. The identification of this may be achieved by the use of machine learning methods. Consequently, the system would continuously monitor the levels of air pollution in real-time and provide predictions about the future readings within a certain time frame. The data would be sent to the network using WiFi connection. The system consisted of an Arduino UNO V3, an ESP8266 WiFi module, and a MQ2 gas sensor during the first stage of development. This provides assistance to urban planning. Air is an essential component in the existence of human beings. In contemporary society, the escalation of air pollution has become a matter of great concern, leading to the phenomenon of climate change and subsequently imposing detrimental effects on the global population. The atmospheric

Authors

Ch. Remesh Babu

Professor
Department of CSE
Matrusri Engineering College
Hyderabad, India.
chramesh522@gmail.com

S. Dilli Babu

Associate Professor
Department of CSE
Mohan Babu University
Tirupati, India.
dillibabusalvakkam@gmail.com

pollution is attributed to the production of toxic gases by industrial activities and vehicle exhaust, resulting in an escalation of detrimental gases and particulate matter in the surrounding air. The release of diverse harmful gases from industrial and vehicular sources poses a significant threat to both terrestrial organisms and marine ecosystems. The prevalence of health conditions such as stroke, heart illnesses, lung cancer, respiratory disorders, and others is increasing as a consequence of inadequate air quality. The presence of substandard air quality presents a notable hazard to certain vulnerable populations, including children, those with asthma, pregnant women, and the elderly. Furthermore, these pollutants are accountable for the degradation of our infrastructure and cultural landmarks. It is vital for individuals to acquire knowledge about the magnitude of their actions' impact on air quality. According to statistical data from the World Health Organisation (WHO), a significant number of early deaths occur annually on a global scale as a result of air pollution. The findings of several research have shown that particulate matter plays a significant role in the escalation of air pollution. Consequently, air quality has emerged as a significant global problem. Therefore, it is important to consistently check the air quality index in order to cultivate a healthy surrounding environment that is conducive to human habitation.

I. INTRODUCTION

The presence of air is necessary for the survival of living things, including humans. In today's culture, the worsening of air pollution has emerged as a major source of worry. This is because it is a major contributor to the phenomena of climate change, which, in turn, has a negative impact on the population of the whole world. The release of poisonous gases from industrial activity and cars is the primary contributor to atmospheric pollution. As a consequence, there is a significantly increased concentration of potentially harmful chemicals and particulate matter in the air around us. The enormous danger that is posed to terrestrial species and marine ecosystems alike by the emission of various toxic gases from industrial and vehicular sources has been brought about by the discharge of these gases. As a direct consequence of poor air quality, a rising number of people are suffering from a variety of health problems, including but not limited to strokes, heart diseases, lung cancer, and respiratory ailments. The existence of poor air quality poses a significant threat to some vulnerable groups, such as children, people who suffer from asthma, pregnant women, and elderly people. In addition, the deterioration of our nation's infrastructure and historical landmarks may be directly attributed to these pollution emissions. It is essential for people to educate themselves on the extent of the influence their activities have on the quality of the air around them. According to research findings compiled by the World Health Organisation (WHO), air pollution is responsible for a sizeable proportion of the premature deaths that take place on a yearly basis throughout the whole planet. According to the results of recent research, particulate matter plays a key impact in the progression of air pollution. As a direct result of this, the problem of poor air quality has developed into a substantial concern on a worldwide scale. As a result, it is essential to examine the air quality index on a regular basis in order to develop a healthy surrounding environment that is suitable for human habitation. The availability of a platform that allows users to evaluate the quality of the air in their immediate surroundings is what is meant by the term "air quality monitoring." The establishment of a system for monitoring air quality will make it possible for us to determine the present status of air quality, particularly as it relates to the air that we breathe in. The Internet of Things (IoT) is being put to use in an expanding number of industries, one of which is the monitoring of air quality systems due to the substantial contribution it makes in this area. This work focuses on the design and implementation of an Internet of Things (IoT) technology-based Air Quality Index Monitoring System, more especially on the ESP 32 platform. Using a variety of sensors, the system would offer readings for the temperature and humidity of the air, as well as the air quality measured in parts per million (PPM). After that, these readings will be shown on a platform that uses the Internet of Things (IoT). It is recommended that the dashboard of the platform be set up to have a public configuration, which will give people unlimited access to monitor the air quality in the location that has been specified for the installation. We can easily keep an eye on it by utilising either our desktop computer or one of our mobile devices. Our group's major duty is to lessen the negative effects that our actions have on the environment by putting into place procedures that will cut the amount of harmful gases released into the atmosphere by a variety of sources, including industries and automobiles. Monitoring the quality of the air in real time permits the timely application of suitable protections if and when they are needed.

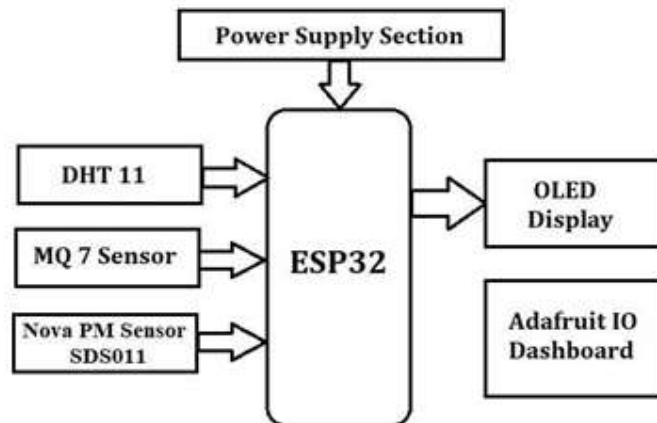

Figure 1: Air Pollution Detector Overview

The discharge of harmful gases by industrial activity, the emissions from cars, and the increased buildup of harmful gases and particle matter in the atmosphere are the primary causes of air pollution. Other factors contributing to air pollution include particle matter and the accumulation of harmful gases. As a result of various factors, including industrial activity, urban expansion, population growth, and increased automobile use, the rate at which pollution is increasing is quickly accelerating. These factors, along with others, have the potential to have a negative influence on the well-being of humans. The presence of particulate matter is an essential quality that is accountable for a significant portion of the progression of air pollution. This research presents a real-time autonomous system for detecting the quality of the surrounding air. The Internet of Things (IoT) is now enjoying widespread adoption across a variety of industries, one of which is the monitoring of air quality systems due in large part to its major contribution. The setup will show the concentration of air pollutants on a website in parts per million (PPM), making monitoring much more straightforward. There is a substantial amount of contamination in the air conditioning system. In recent years, there has been a widespread presence of emissions from automobiles, chemicals used in industry, smoke, and dust in a variety of different situations. This is the primary factor contributing to the alarmingly high amounts of air pollution that are now being produced by air conditioning systems. It should come as no surprise that pollution in the air has a highly negative effect on human health, and this is especially true in environments where it is necessary to breathe in air in order to survive. Asthma, coughing, and pulmonary disorders are just some of the problems that may be brought on by the presence of certain conditions inside the respiratory system, namely the lungs. These conditions have the ability to bring on a wide range of other conditions as well. The human senses are unable to detect the presence of air pollution. There are a number of potentially harmful contaminants that may be found in polluted air, some of which include methane, carbon monoxide, and LPG gas. There are major risks involved due to the presence of chemicals in the polluted air. For instance, people may feel symptoms such as dizziness and nausea when the quantity of carbon monoxide is higher than 100 parts per million (ppm). In the most severe circumstances, death may occur in a matter of minutes at the earliest.

II. IOT RELATED STUDY

- 1. IOT Based Air Pollution Monitoring System:** Regardless of a country's overall level of development, combating air pollution is a critical concern for all countries. The incidence of health problems has been expanding at a rapid speed, especially in the urban districts of developing countries' metropolitan areas. This may be because to the fast industrialization and the consequent growth in the number of vehicles, both of which have led to the release of a substantial quantity of gaseous pollutants into the atmosphere. The negative effects of pollution range from mild allergic reactions, such as irritation of the throat, eyes, and nose, to more serious conditions, such as bronchitis, heart disease, pneumonia, lung problems, and asthma that is made worse. According to the conclusions of a research, there are between 50,000 and 100,000 premature deaths that take place every year in the United States as a direct result of air pollution. This number was established based on the findings of the study. In the European Union, the number of people who have been impacted is estimated to be around 300,000. On a worldwide scale, the number is estimated to surpass 3,000,000. The Internet of Things-based Air Pollution Monitoring System is intended to check the quality of the air by way of a web server connected to the Internet. When the air quality goes below a certain threshold level, it is set to sound an alert. This level was selected beforehand. This takes occur when there is a substantial amount of toxic gases in the air, such as CO₂, smoking, alcohol, benzene, NH₃, LPG, and NO_x. The parts per million (PPM) reading of the air quality will be shown on a web page as well as the LCD screen, making monitoring the environment more easy.
- 2. IOT Based Air Quality Monitoring System:** The major objective of this chapter is to conduct an analysis of the air quality in both industrial and urban areas. The idea that has been detailed includes the use of gas sensors, namely for carbon monoxide (CO) and nitrogen dioxide (NO₂), which are positioned in an advantageous manner on different components and structures of an Internet of Things (IoT) system. In addition, there is a central server that is included into the solution. Its objective is to give real-time event management in close proximity as well as continuing intentional planning activities. Data transmission that is both quick and effective may be accomplished using the Arduino platform. Wireless sensor networks, often known as WSNs, may function as transceivers. This system provides a real-time monitoring solution for wireless communication technology that functions at low rates, produces very little information, and offers very little in the way of control. The monitoring system, which is broken up into sections, is able to be communicated to or shared with many applications thanks to its chapter-based organisation. We are now able to effectively display data coming from a variety of places all over the globe thanks to the deployment of the Internet of Things (IoT). This article identifies the absence of sensor calibration and the inability to convert sensor output numbers into parts per million (PPM) as one of the problems that need to be addressed. According to the guidelines that were made available by UN Data, a value that falls anywhere between 0 and 50 is regarded to be within the safe category, while a number that falls anywhere between 51 and 100 is considered to be within the moderate area. It has been determined that Delhi is the city in the world that has the worst amounts of pollution ever measured, coming in at a whopping 350 parts per million (PPM). When employing two sensors, the presence of internal heat components in each of the sensors will result in an increase in the amount of power that is used. As a consequence of this,

the output voltage levels of both sensors vary and show the expected values due to insufficient driving capacity. This occurs despite the fact that both sensors have been enabled. For the purpose of our investigation, we powered the CO sensor MQ7 using a 9V battery and a family regulator from the 7805 series. The Arduino microcontroller is the only source from which the power supply for the MQ135 sensor may be obtained.

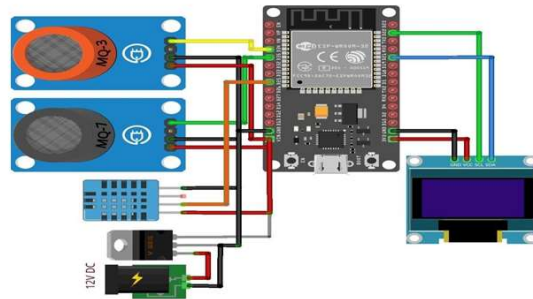

Figure 2: Sensor Overview

- 3. Arduino Based Weather Monitoring System:** This study uses a combination of three sensors to quantify several environmental parameters related to weather conditions, including light intensity, dew point, and heat index. The data obtained from the sensors is analysed by the Arduino micro-controller and afterwards saved in a text file for further processing. The measurements are furthermore shown on an onboard liquid crystal display (LCD) to facilitate rapid observation. The aforementioned observations may be subjected to analysis in order to derive the meteorological attributes specific to a certain region and document the prevailing weather trends. The aforementioned collected metrics are of utmost importance and exhibit variability across different geographical locations.

III. AIR POLLUTION DETECTORS

People who are new to the subject of microcontrollers and embedded systems sometimes consider the Arduino platform to be a great starting point because of its user-friendliness and versatility. One is possible to participate in the construction of a variety of projects, whether for the goal of a personal pleasure or for the prospective objectives of a company, by making use of a wide variety of inexpensive sensors and modules. The development of technology has led to the birth of a plethora of novel ideas and software programmes, one of which is known as the Internet of Things (IoT). The platform in issue is a networked system that allows for the free flow of information by connecting a variety of different items or gadgets to one another over the internet. Home automation and smart home applications are often given the most priority within the Do It Yourself (DIY) community's Internet of Things (IoT) chapters. Nevertheless, the commercial and industrial sectors of IoT chapters have more complex implementations. These include, amongst other things, machine learning, artificial intelligence, and wireless sensor networks. The availability of an internet connection is the primary topic of discussion that will be covered in this brief introduction to the Internet of Things (IoT). This is true for any Internet of Things (IoT) chapter, regardless of whether it is a simple do-it-yourself venture carried out by an amateur enthusiast or a complex industrial project. In this

particular setting, some notable examples include the ESP8266 and the ESP32. When deciding how to include Wi-Fi networking into your chapters, the ESP8266 is a product that comes highly recommended. On the other hand, if one wishes to build a full system that is capable of connecting through Wi-Fi and Bluetooth, having high resolution ADCs and DACs, connecting via Serial, and having a number of additional features, the ESP32 presents itself as the best choice among the available options.

- 1. ESP32:** The ESP32 is a System on Chip (SoC) Microcontroller that is made by Espressif Systems, the same company that was responsible for the production of the well-known ESP8266 SoC. The ESP8266 System-on-Chip (SoC), which is the gadget that is being discussed here, has undergone yet another development. The Tensilicas 32-bit Xtensa LX6 Microprocessor is available in either a single-core or dual-core configuration, depending on the version of the product you choose to purchase. This microcontroller has built-in capability for both Bluetooth and Wi-Fi networking protocols. One of the benefits of the ESP32, which is also included in the ESP8266, is the integration of integrated RF components, such as the Power Amplifier, Low-Noise Receive Amplifier, Antenna Switch, Filters, and RF Balun. This is comparable to the design of the ESP8266. Because there are just a few components external to the ESP32 that are necessary, the process of designing hardware around it is significantly simplified. The fact that the ESP32 is manufactured using the sophisticated ultra-low-power 40 nm manufacturing process developed by TSMC is an extra important facet to take into consideration. On the ESP32 platform, the challenge of designing battery-operated applications like smartwatches, wearables, music equipment, and baby monitors is anticipated to be a simple one.
- 2. Specifications of ESP32:** Since the ESP32 microcontroller offers a broader variety of functionality than the ESP8266, it is tough to incorporate all needs within the limitations of this basic tutorial for utilising the ESP32. The ESP8266 microcontroller has less capabilities than the ESP32 microcontroller. I have put up a detailed summary of the essential characteristics that are associated with the ESP32. Having said that, it is strongly suggested that you reference the Datasheet in order to get an exhaustive list of the specifications.
 - The LX6 microprocessor is a 32-bit central processing unit that may either have a single core or two cores, and its clock frequency can reach up to 240 megahertz.
 - The system has 520 kilobytes (KB) of memory with static random access (SRAM), 448 KB of memory with read-only access (ROM), and an extra 16 KB of memory with real-time clock static random access (RTC SRAM).
 - Wi-Fi networking that supports 802.11 b/g/n is included in the gadget, and it is capable of transferring data at a maximum speed of 150 Mbps.
 - The device is compatible with both the Classic Bluetooth v4.2 protocol as well as the Bluetooth Low Energy (BLE) protocol.
 - A total of 34 general-purpose input/output (GPIO) pins are available for programming.
 - The system is capable of supporting a maximum of 18 channels for the 12-bit Successive Approximation Register (SAR) Analog-to-Digital Converter (ADC), in addition to supporting a maximum of 2 channels for the 8-bit Digital-to-Analog Converter (DAC).

- The system's serial connection choices include three Universal Asynchronous Receiver-Transmitter (UART) channels, two Inter-Integrated Circuit (I2C) interfaces, four Serial Peripheral Interface (SPI) ports, and two Integrated Interchip Sound (I2S) ports. Additionally, the system has four Serial Peripheral Interface (SPI) ports.
- The Ethernet Media Access Control (MAC) protocol is used to facilitate communication inside a physical Local Area Network (LAN), and it requires the usage of an external Physical Layer (PHY) in order to do so. This is because the MAC protocol relies on the Ethernet standard.
- The system is made up of one host controller that is in charge of controlling SD/SDIO/MMC operations and one slave controller that is solely responsible for managing SDIO/SPI connectivity.
- The system is capable of supporting motor pulse width modulation (PWM) in addition to light-emitting diode (LED) pulse width modulation (PWM) on up to 16 separate channels.
- Secure Boot and Flash Encryption are two of the interesting subjects that will be discussed.
- In this work, the implementation of cryptographic hardware acceleration for a variety of algorithms, such as RSA, ECC, AES, Hash (SHA-2), and RNG, is analysed and discussed.

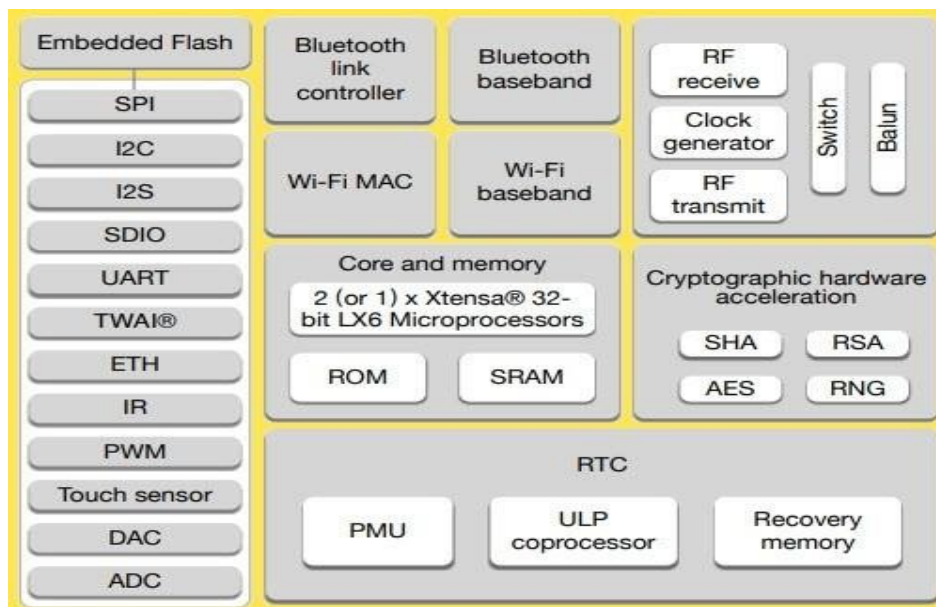

Figure 3: ESP32

3. Different Ways to Program: By permitting programming variety and providing a number of different coding alternatives, one may make high-quality hardware like ESP32 more user-friendly. This can be accomplished by providing several coding possibilities. It should not come as a surprise that the ESP32 is compatible with a number of different programming environments. In later chapters, the ESP32 will be programmed using the Arduino IDE since it is an environment that is already well known to the reader. However, it is best to look into the availability of different choices.

- 4. ESP32 DevKit -The ESP32 Development Board:** Espressif Systems has released a variety of modules that are designed around the ESP32 platform. Among these modules, the ESP-WROOM-32 Module has proven to be one of the most popular options with customers. In all, the system is made up of a 40 MHz crystal oscillator, an Integrated Circuit (IC) with 4 MB of Flash memory, an ESP32 System-on-Chip (SoC), and a few additional passive components.



figure 4: ESP-WROOM-32 Module

The presence of edge castellations on the printed circuit board (PCB) of the ESP-WROOM-32 Module is a feature that might be considered a benefit of this component. A break-out board that is conceptualised and developed particularly for the ESP-WROOM-32 Module is a process that is carried out by third-party manufacturers. The process begins with the module itself and continues with the module's development. The ESP32 DevKit Board is a good illustration of this kind of board. The ESP-WROOM-32 is the major module that is used in this system. It is supplemented with extra hardware that makes it easier to programme the ESP32 and permits smooth interaction with the GPIO Pins.



Figure 5: ESP32 Board

5. **Layout:** In this research, we will investigate the components that make up a typical ESP32 Development Board. More specifically, our attention will be drawn to the layout of the ESP32 DevKit Board, which is an option that is readily available and very inexpensive on the market. The ESP32 Development Board that I now have is configured as shown in the above graphical depiction. I currently have this board in my hands. It is essential to be aware that while there is a large variety of ESP32 boards now available for purchase, each of these boards is founded on the ESP-WROOM-32 module. There are several distinct boards, each of which has its own unique layout, pinout, and functionality. The circuit board that I have in my hands has a total of 30 pins, with 15 pins situated on either side of the board. There are certain circuit boards that have a total of 36 pins, and there are also other circuit boards that have a somewhat lower number of pins than the former. Before making any connections to the board or turning on the power supply, it is in everyone's best interest to do a careful check to ensure that the pins are correctly aligned and in good condition.

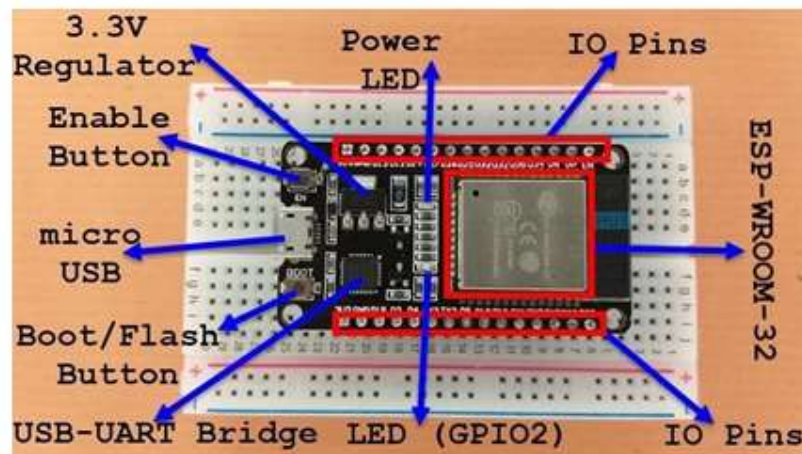

Figure 6: Labelling Of ESP32

The following are some of the components that make up the ESP32 Board, which are seen in the figure: It is important to note that the USB-to-UART integrated circuit (IC) makes use of the DTR and RTS pins to allow automatic activation of the ESP32 into programming mode as required and to reset the board after programming. This is an important function of the integrated circuit.

6. **Pinout of ESP32 Board:** The ESP32 Pinout will be the subject of its own dedicated lesson that we plan to provide in the near future. Have a look at the diagram that illustrates the pinouts on the ESP32 Development Board while we wait for it to take place. The pinout that has been supplied applies to the version of the ESP Board that has 30 pins. The purpose of this lesson is to clarify the pinout arrangement of both the 30-pin and 36-pin variations of the ESP Boards that are available.

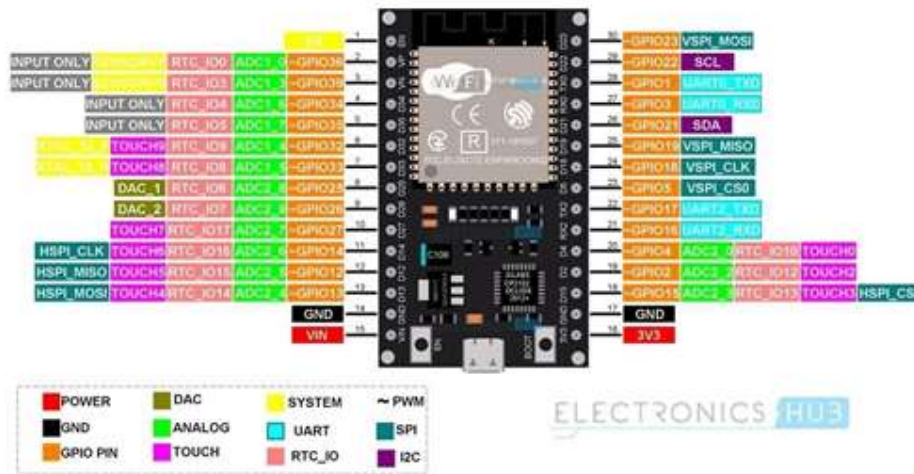

Figure 7: Pin Labelling Of ESP32

IV. METHODOLOGY

The suggested architecture incorporates a monitoring system for the air quality that is based on the concepts that underpin the Internet of Things (IoT). The sensors that were used in this investigation made it possible to identify and quantify the presence of certain toxic gases, airborne particulate matter, as well as the monitoring of temperature and humidity levels at any given instant. The controller is connected to the sensors in a manner that is determined by the kind of output that the sensors provide, which might either be analogue or digital. In addition to having an inbuilt Wi-Fi module that allows the transfer of the recorded data to an Internet of Things (IoT) platform, the controller has been developed to gather data from a wide variety of sensors. This data can then be viewed and analysed as needed. The platform for the Internet of Things (IoT) was developed to successfully store sensor data in real time while simultaneously giving the potential to produce visual representations such as graphs, charts, and numeric values. This was accomplished by designing the IoT platform with certain key characteristics. As a direct result of this, the technology would make it possible for us to continually monitor the air quality at the particular location in real time.

The block architecture of the air quality monitoring system created for this research is shown in Figure 7, which may be seen below. Within our system, the ESP32 microcontroller serves as the key component for carrying out control functions. The sensors are picking up a wide variety of environmental factors, such as Carbon Dioxide and Carbon Monoxide as well as particulate matter, Temperature, and Humidity. The ESP32 microcontroller has connections made to accommodate the sensors. The ESP32 gadget communicates with a variety of sensors in order to gather data, which it then uploads to the cloud on a regular basis. When referring to the measurement of the diameter of the particles, the words 2.5PM and 10PM are used to refer to the particles having diameters of 2.5um and 10um, respectively. The sensor is able to identify the presence of particulate matter at concentrations as high as 2.5 PM. An analogue output may be obtained from the gadget. Our system also has additional analogue sensors such as the MQ7, which is a gas sensor used for the measurement of carbon monoxide, and the MQ135, which is an air quality sensor used for the measurement of carbon dioxide. Both of these sensors detect carbon monoxide and carbon dioxide,

respectively. A digital output may be obtained from the DHT11 sensor, which is often used for the purpose of monitoring temperature and humidity. The information gathered by the sensors is continuously sent to a platform that makes use of the Internet of Things (IoT) in order to perform real-time monitoring of the air quality. Thing Speak was chosen as the Internet of Things (IoT) platform for our research project. The collected sensor data is shown by Thing Speak in the form of graphical representations as well as numerical values.

- 1. System Design:** The major focus of the system that is being suggested is on the non-stop monitoring of the circumstances of both the patient and the patient's room by means of an online platform. As a result, the framework that supports the healthcare monitoring system is an architectural one that is composed of three stages and the following components: (1) Sensor Module, (2) Data Processing Module, and (3) Web User Interface are the three main components of this system. The wired sensors are used for the goal of acquiring physiological signals from the bodies of patients as well as the surroundings around them for the purposes of data collecting. After the data has been acquired, it is transmitted to an ESP32 module for processing before being sent to the gateway server. In the framework of the web user interface, graphical representation and presentation of the compiled results are carried out with the assistance of Thing Speak. Thing Speak delivers real-time updates and information on the state that transactions are now in as well as their progression. The Hypertext Transfer Protocol (HTTP) makes it possible for a Wi-Fi module and a web server to communicate with one another in a smooth manner. Real-time monitoring of patients is made possible thanks to the fact that the user interface of the HTML is updated frequently at intervals of 15 seconds.

The complete system architecture of the newly built system is shown in Figure 2, which can be seen here. Figure 2 depicts the use of a variety of sensors for the purpose of data collecting inside a healthcare environment. A central processing unit known as the ESP32 is linked over a network to each of the many sensors. The ESP32 acts as the primary component of the system since it incorporates a number of different sensors, including ones that measure temperature, heartbeat, and gas. The ESP32 gadget is in charge of collecting sensor data, which is subsequently wirelessly sent to websites that are associated with the Internet of Things (IoT). In addition to making advantage of the board's Wi-Fi functionality, the Xtensa dual-core 32-bit LX6 CPU, which is a proprietary processing unit, is included on the board. After then, the information gathered by the sensor is sent to an Internet of Things (IoT) website. Any device that can connect to the network and is supported by it may be used to access the data. Inside of a channel-based system, the data is graphically displayed in a graphical manner, and the user is required to authenticate themselves with a password before gaining access to the system.

- 2. DHT11 Sensor:** The DHT11 Temperature & Humidity Sensor is outfitted with a sensor complex that is capable of measuring both temperatures and levels of humidity. An accurate digital signal may be produced by this complex with the appropriate calibration. The use of the one-of-a-kind digital-signal-acquisition strategy, in combination with the development of temperature and humidity sensor technology, ensures a high degree of dependability in addition to an outstanding level of stability over the long term. The resistive-type humidity measurement component and the NTC temperature measurement component of the sensor are coupled to a high-performance 8-bit microprocessor so that the sensor can monitor both temperature and humidity. This arrangement offers

exceptional quality, quick reaction, a strong capacity to avoid interference, and cost-effectiveness.

In order to achieve accurate humidity calibration, the DHT11 elements go through stringent calibration procedures in an extremely precise laboratory environment. The calibration coefficients are stored as programmes in the OTP memory, and the sensor's internal signal detection algorithm makes use of them. The calibration coefficients are employed. Integration of systems may be accomplished in a quick and painless manner by making advantage of the single-wire serial interface. Because of its small size, low energy consumption, and the capacity to send signals up to 20 metres away, it is an excellent option for a diverse variety of applications, including those that place a premium on performance. The component comes in a pin package with four pins and a single row. A beneficial aspect is the ability to create connections and give individualised packages based on the specific requirements of each customers.

- 3. How the DHT11 Measures Humidity and Temperature:** The DHT11 analyses the data from the measurement of the electrical resistance that occurs between two electrodes in order to calculate the relative humidity. The element that detects humidity in a DHT11 sensor is made up of a substrate that can hold onto moisture. This substrate is often made of a salt or conductive polymeric polymer, and electrodes are attached to it. The substrate's ability to take in water vapour ultimately results in the release of ions, which in turn results in an increase in the conductivity between the electrodes. The degree of change in resistance and the relative humidity have a connection that is directly proportionate to one another. Alterations in the relative humidity have an inverse effect on the resistance between the electrodes. When the relative humidity is high, the resistance between the electrodes decreases, and when the relative humidity is low, the resistance between the electrodes increases. On the front substrate of the DHT11 chip, there is clear evidence of the presence of electrodes. The DHT11 sensor has an integrated circuit (IC) that is situated on the back of the device. This IC is responsible for converting resistance data into values indicating the relative humidity. After that, it instantly sends the data about the temperature and humidity that it has captured to the Arduino. The integrated circuit (IC) in issue is accountable for storing the calibration coefficients as well as managing the passage of data signals between the DHT11 sensor and the Arduino microcontroller. Both of these responsibilities fall within the purview of the integrated circuit. The surface-mounted negative temperature coefficient (NTC) temperature sensor that is built into the DHT11 and is the source of the temperature readings it provides is the component that is responsible for providing these readings. Referring to our tutorial titled "Arduino Thermistor Temperature Sensor Tutorial" is highly recommended for anybody interested in gaining a complete grasp of thermistors and how they may be used on the Arduino platform. The DHT11 just requires one signal wire to digitally communicate sensor readings to the Arduino, which is accomplished via the use of the Arduino. The power is provided by separate connections to 5V and ground. A pull-up resistor with a resistance range of 5K to 10K Ohm is used to link the signal line to a source of 5V. This allows for the provision of a high signal level as the default setting. Please refer to the datasheet if you want any more clarification on the signal transmission. There are two different iterations of the DHT11 sensor that you could come across. There is one type that is identified by the presence of four pins, and another category that is distinguished by its connection to a small printed circuit board (PCB) that includes three

pins. Both of these categories may be recognised from one another. The PCB-mounted model with three pins offers an advantage since it incorporates a surface-mounted 10K Ohm pull-up resistor for the signal line. This makes the PCB-mounted type more desirable.

- 4. MQ 7 Sensor:** The MQ-7 sensor was developed particularly for the detection and measurement of carbon monoxide (CO) concentrations in the environment around it, with the results being reported in terms of parts per million (PPM). The MQ-7 sensor is able to measure carbon monoxide (CO) concentrations in a range that is anywhere from 20 to 2000 parts per million (ppm). The sensor has a quick response time and a high degree of sensitivity to changes in its environment. The sensor provides an output in the form of an analogue resistance reading. A straightforward voltage divider is the best way to explain the driving circuit. A power supply that is either 5V DC or AC is essential for the operation of the heating coil. In addition, a load resistance need to be included, and the resultant output ought to be linked either to an ADC or a fundamental OPAMP comparator. The packaging of the sensor is equivalent to that of our MQ-3 alcohol sensor, and it is compatible with the rhydoLABZ breakout board. Additionally, the sensor measures alcohol levels.

5. Applications, Advantages and Future Scope:

- **The Monitoring System for the Quality of Air Inside the Structure:** The fact that indoor air pollution is responsible for the deaths of about 3.8 million people every year is a startling and highly concerning discovery. It has been observed that the decrease in air quality that is brought on by an increase in the quantity of pollutants and dangerous substances has a negative impact on the health of humans. Inhaling air that is this dirty has been related to the development of a number of dangerous ailments, such as asthma, decreased lung function, and even cancer.
- **The System for the Monitoring of the Quality of the Outdoor Air:** Since many decades ago, people have been debating various aspects of the concept of sustainability. In order to accomplish the goal of preserving a high degree of air quality, a number of rules and regulations have been passed and put into effect to control the amount of pollutants that may be released into the sky. For this reason, it is very necessary for businesses to perform vigilant monitoring of the production of harmful gases in order to properly manage the emission rate in compliance with the standards that have been set.
- **Observation and Measurement of Particulate Matter:** Particulate matter (PM), often known as airborne particles, is measured in micrograms per cubic metre. Particulates are defined as minute particles that may be either solid or liquid and that are suspended within the atmosphere. These very minute particles, which are more often referred to as aerosols, are invisible to the naked eye and may be composed of a wide variety of components, including, but not limited to, acids, metals, dirt, dust, organic molecules, and so on. Because of their small size, these particles have a greater likelihood of being inhaled, which increases their potential to have an adverse effect on human health. The extent of the health issues is directly proportional to the sizes of the particles in question. The size range of the coarse particulate matter (PM)

that is often found in close proximity to roadways or dusty industrial areas ranges from 2.5 micrometres all the way up to 10 micrometres. Nevertheless, particles with a diameter of less than 2.5 micrometres provide a larger risk because of their capacity to easily pass through the nose and throat passages and enter the pulmonary system. This makes them particularly dangerous.

- **Keeping an Eye on the Gas Detection Equipment:** The gas detection system is a piece of technical equipment that was developed to detect and keep track of the presence of gases in a certain setting. In industries such as the chemical and oil and gas industries, whose industrial processes include the usage or manufacture of dangerous gases and poisons, even the smallest discharge of these substances has the potential to result in a disastrous situation. This specific system is capable of being utilised in two different ways: first, as an independent device, as was shown in the previous example, and second, it may be incorporated into other vehicles. Both of these applications are possible. Drivers would gain information and understanding about their driving behaviours and the resulting effect such habits have on the environment, notably in terms of higher levels of pollution, if this technology were implemented in vehicles. It is anticipated that the implementation of more environmentally responsible driving practises would lead to a subsequent reduction in the levels of pollution. The decrease in pollution will have positive effects not just on individuals but also on the larger community as a whole. This is because it will lead to an improvement in air quality, which will make it possible for everyone to breathe in cleaner air. In succeeding generations of the system, more sensors may be added to it, which would result in an expansion of the capabilities it has. In addition, the system may be improved by including a capability that allows the delivery of Short Message Service (SMS) alerts to the user in the event that the concentration of any gas within the environment exceeds a criterion that has been established in advance. These technologies also have the potential to be used on a substantial scale, which would contribute to the creation of a smart city.

V. CONCLUSION

In this chapter, we take a look at a potential solution for monitoring the air quality on a localised scale in real time, with the goals of reducing costs and power usage while maintaining a high level of precision. This is made possible by the employment of specialised sensors that instantly inform folks when the air quality reaches a predefined level that is higher than it was before. In addition to this, the system guarantees that the gathered information is presented in a way that is understandable to each individual user. Individuals, regardless of where they are physically located, are now able to conduct remote monitoring of the environmental conditions around a specific system via the use of a mobile device or computer, which is made possible by leveraging the fundamentals of the Internet of Things (IoT). Users are granted the ability to immediately and effectively react to circumstances as they emerge as a result of the continuing process of data update. This approach helps to mitigate air pollution in the surrounding environment, which is a big area of concern, and it does so in a way that is beneficial. In addition to its low cost and high efficiency in the use of energy, this technology has a space-saving form factor and a wide range of flexible installation choices. This feature enables considerable gains in both the productiveness and adaptability of the system.

REFERENCES

- [1] Kennedy Okokpujie, EtinosaNoma-Osaghae, OdusamiModupe, Samuel John and OlugaOluwatosin, A Smart Air Pollution Monitoring System, International Journal of Civil Engineering and Technology, 9(9), 2018, pp.799809.
- [2] Rawal R. Air Quality Monitoring System. International Journal of Computational Science and Engineering.2019;9(1):1-9.
- [3] Ali, Hassan &Soe, J. & Weller, Steven. (2015). A real-time ambient air quality monitoring wireless sensor network for schools in smart cities. 1-6.10.1109/ISC2.2015.7366163.
- [4] Kumar S, Jasuja A. Air quality monitoring system based on IoT using Raspberry Pi. In2017 International Conference on Computing, Communication and Automation (ICCCA) 2017 May 5 (pp. 1341-1346).IEEE.
- [5] Gupta, Harsh & Bhardwaj, Dhananjay& Agrawal, Himanshu&Tikkiwal, Vinay & Kumar, Arun. (2019). An IoT Based Air Pollution Monitoring System for Smart Cities. 173-177. 10.1109/ICSETS.2019.8744949.
- [6] Kumar A, Kumari M, Gupta H. Design and Analysis of IoT based Air Quality Monitoring System. In2020 International Conference on Power Electronics &IoT Applications in Renewable Energy and its Control (PARC) 2020 Feb 28 (pp. 242-245).IEEE.
- [7] AsraNoorain F, Raju J, Varsha V, Nanditha HG. An IoT Based Approach To Minimize And Monitor Air Pollution Using ESP32 and BlynkPlatform.
- [8] Jayaratne R, Liu X, Ahn KH, Asumadu-Sakyi A, Fisher G, Gao J, Mabon A, Mazaheri M, Mullins B, Nyaku M, Ristovski Z. Low-cost PM2. 5 sensors: An assessment of their suitability for various applications. Aerosol and Air Quality Research.2020;20(3):520-32.