

OVERVIEW OF OPERATIONAL TRANSCONDUCTANCE AMPLIFIER (OTA)

Abstract

An essential component of electronic systems is the operational transconductance amplifier (OTA). A transconductor's job is to turn an input voltage into an output current. The transconductance amplifier can be set up to either amplify or combine currents or voltages. An OTA can be used in many electronic systems, such as oscillators, filters, and analog to digital converters, due to its versatility. An operational amplifier also uses an OTA as its core amplifier. Numerous analog systems are dependent on the OTA. In linear applications, OTAs are also more frequently utilized in open-loop configurations devoid of negative feedback. This is because the high resistance at the output, which controls the voltage at the output and can be specifically set to prevent the OTA from reaching saturation even at relatively high differential input voltages, prevents the OTA from reaching saturation.

The differential input voltage is multiplied by the transconductance of an ideal OTA to yield the output current. An ideal OTA's output voltage is a function of the load resistance and the output current. As a result, the transconductance of the OTA and the load resistance create the voltage gain at the output. An amplifier bias current that is used to regulate the transconductance is directly proportional to the transconductance.

Keywords: Transconductance, configurations, bandwidth, operational amplifier.

Author

Shadab Ahmad
Ph.D Scholar
Electronics and Communication Engineering
Maharishi University of Information
Technology
Lucknow, India

I. INTRODUCTION

Generally, a simple operational amplifier ICs give an **output voltage which is proportional to the difference of the two voltages applied to its input terminals**, called as voltage differential amplifier (VDA).

$$V_o \propto (V_{in+} - V_{in-})$$

Other than that two more types of op-amps that are common in usage; one of them is a type of that provides an **output voltage which is proportional to the difference of the two currents applied to its input terminals**, called as current differential amplifier (CDA).

$$V_o \propto (I_{in+} - I_{in-})$$

And another type of op-amp is called as operational transconductance amplifiers (OTA), which perform as a variable gain and voltage controlled current source (VCCS) amplifier which means that it provides an **output current which is proportional to the difference of the two voltages applied to its input terminals**, called as an operational transconductance amplifier (OTA).

$$I_o \propto (V_{in+} - V_{in-})$$

Where; $(V_{in+} - V_{in-})$ is a differential voltage (V_d) of an OpAmp at its input terminals .

1. Operational Transconductance Amplifier (OTA): Operational transconductance amplifier converts an input voltage to an output current that's why it is called as **voltage controlled current source (VCCS)**. The OTA can be configured to amplify either voltages or currents. The adaptability of an OTA permits its usage in many electronic systems such as audio signals, filters, analog to digital converters, oscillators etc.

OTAs can build by the help of **Bipolar or CMOS transistor technology**. The Bipolar OTAs are universally used whereas the CMOS OTAs are commonly used in high frequency applications but are less commonly used in audio circuits. The most commonly used OTA symbol is VCCS symbol improved with an additional bias current port (I_{bias}) as shown in figure 1 (a). The general symbol of OTA is set up in circuit schematics as shown in figure.1 (b).

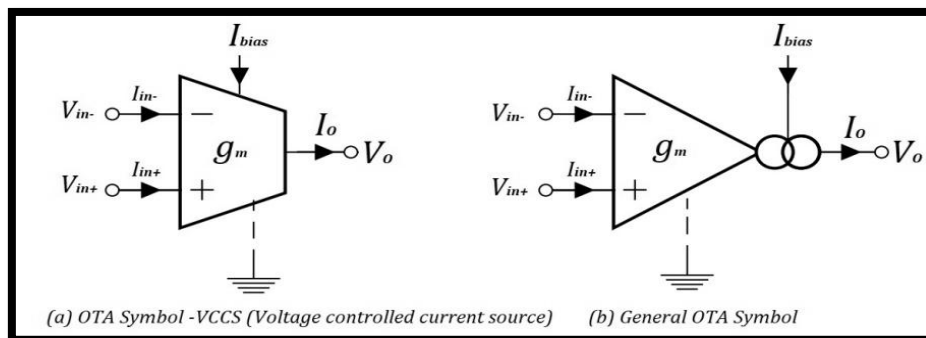

Figure 1: OTA Symbols

What is operational transconductance amplifier (OTA)?:The operational transconductance amplifier is a voltage to current converter amplifier in which output current is equals to the gain times of input voltage. Sometimes, OTA is also called as voltage controlled current source (VCCS). The double cycle in *figure 2.1 (b)* denotes an output current source which depends on the bias current that is I_{bias} .

There are few main characteristics about OTA, it has:

- Two differential input terminals,
- High input impedance,
- High CMRR,
- Bias current terminal,
- High output impedance,
- No fixed open loop voltage gain.

The gain of an OTA is known as **transconductance**. The transconductance of electronic devices is specified by the ratio of the output current to the input voltage or differential voltage.

$$g_m = \frac{I_o}{V_{in}} \quad (2.1)$$

Where, g_m is a **transconductance**, V_{in} is the **differential input voltage** ($V_{in+} - V_{in-}$)

In OTA, the transconductance depends on the value of a constant K times the bias current (I_{bias}) and the value of K depends on the internal circuit of OTA and temperature.

$$g_m = K * I_{bias} \quad (2.2)$$

From *equation 2.1*,

$$I_o = g_m * V_{in}$$

$$I_o = K * I_{bias} * V_{in} \quad (2.3)$$

So, we can see by this *equation (2.3)*, I_o equals to the K times I_{bias} and V_{in} , so the output current is dependent on the value of I_{bias} and the value of input voltage. So we can say that **the output current is controlled by the bias current and the input voltage.**

2. **Symbol and operation of OTA:** The practical symbol of operational transconductance amplifier (OTA) shown in *figure 3.1*, here you can see an Op-Amp has input terminal and output terminal with biased terminal (I_{bias}).

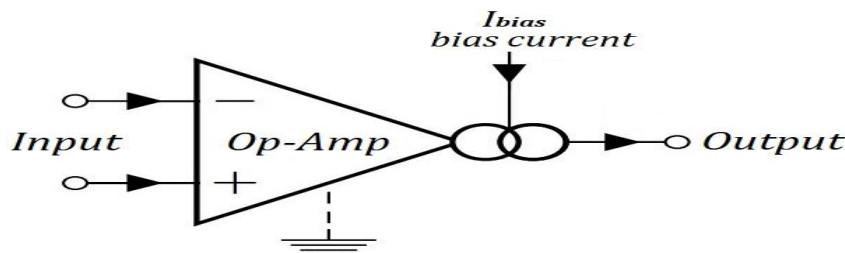

Figure 2: The basic Symbol of OTA

In general the symbolic representation of OTA is shown in fig. 3.2 (a).

The ideal small signal model of OTA is shown in fig. 3.2 (b), here the input impedance (R_i) and output impedances (R_o) are assumed as infinite because of ideal case.

Generally, we know that the transconductance (g_m) of OTA is directly proportional to the amplifier bias current (I_{bias}) from equation (2.2) that is;

$$g_m = K * I_{bias} \tag{3.1}$$

Where, K is the proportionality constant and it depends on the temperature.

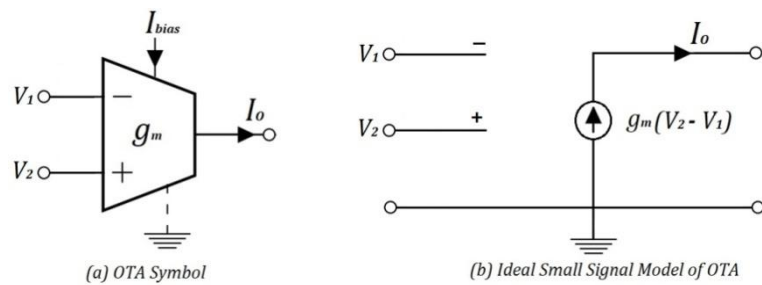

Figure 3: The basic OTA models

For Ideal small signal OTAs model of fig. 3.2 (b), the output current (I_o) is given by;

$$I_o = g_m (V_2 - V_1) \tag{3.2}$$

Where;
 I_o = Output current
 g_m = Transconductance gain
 V_2 = Non inverting input voltage
 V_1 = Inverting input voltage

- 3. Basic circuit and principle of OTA:** This basic circuit of OTA, the input voltage (V_{in}) is connected to the inverting terminal of OpAmp with resistance R_1 and non-inverting terminal grounded with R_2 . The double circles represent the bias current source (I_{bias}) with biasing resistance (R_{bias}) and this bias current flowing through the bias resistance. At output terminal the I_L and R_L are the load current and load resistance respectively.

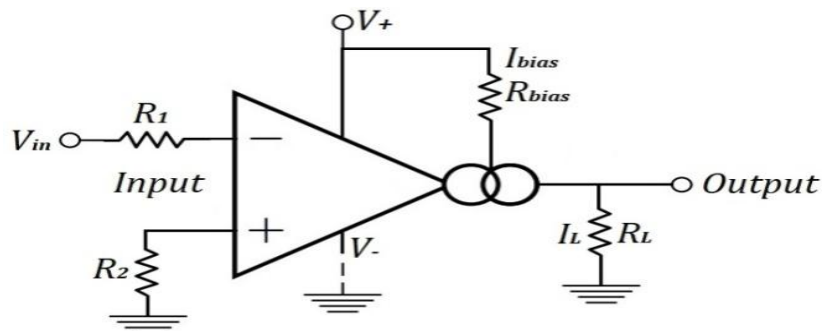

Figure 4: The basic circuit of operational transconductance amplifier (OTA)

The output current (I_o or I_L) depends on the value of bias current and the value of input voltage (V_{in}).

From equation (2.3):
$$I_o = K * I_{bias} * V_{in} \quad (4.1)$$

So, how do we fix the value of bias current? here we have two options:

- Variable Resistor: A variable Resistor can use to fix the value of I_{bias} .
- Reference Voltage: We can use a separate reference voltage to fix the value of I_{bias} .

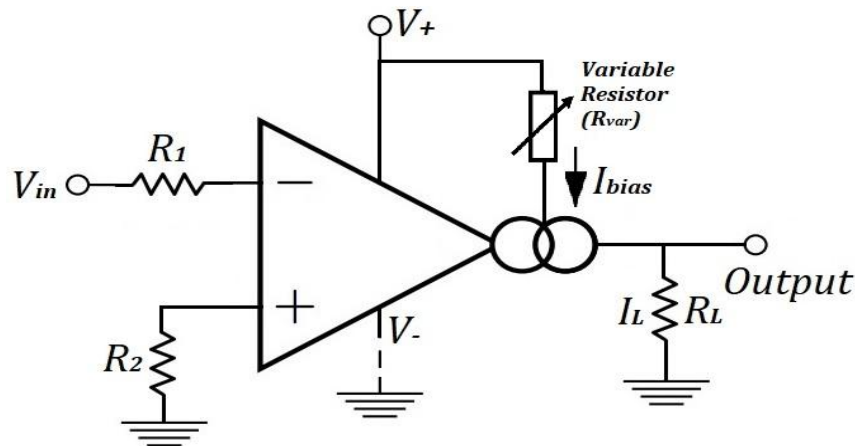

(a) By using variable resistor

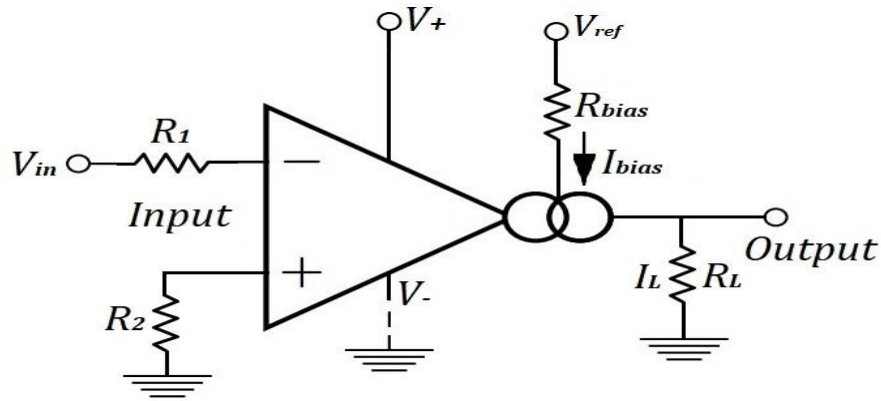

(b) By using reference voltage

Figure 5: To fix the bias Current

We can use a variable resistor in the place of R_{bias} resistor to fix the value of bias current by varying the value of variable resistor or we can use a separate reference voltage or voltage source to fix the value of bias current by changing the value of V_{ref} .

- 4. Basic classification of OTA:** If we discuss about the characteristics of an ideal Op-Amp and ideal OTA both are similar, except output impedance; the OTA has very high output

impedance. Due to high output impedance, the output signal of OTA define in terms of current, which is proportional to the differential input voltages (V_d).

$$I_o \propto V_d$$

\Where, $V_d = (V_{in+} - V_{in-}) =$ differential voltage

The OTA is best defined in terms of its **transconductance gain** (g_m) rather than the **voltage gain** (A_V). The transconductance (g_m) of OTA can be linearly controlled through bias-control current (I_b) or voltage (V_b).OTAs are also available in chip forms. So, the monolithic OTAs can be classified as follows:

- Bipolar OTAs
- MOS OTAs

- **Bipolar OTAs:** The bipolar OTAs are usually available as typical chips from various IC manufacturing companies. They obtained as single device, as dual OTA on a chip and as triple OTA on a chip. Bipolar OTAs are also available in Enhanced performance OTAs, with on chip buffers and linearizing diodes.

A simple bipolar differential pair OTA as shown in figure which converts the difference of input voltage to the currents (I_{B+} and I_{B-}).

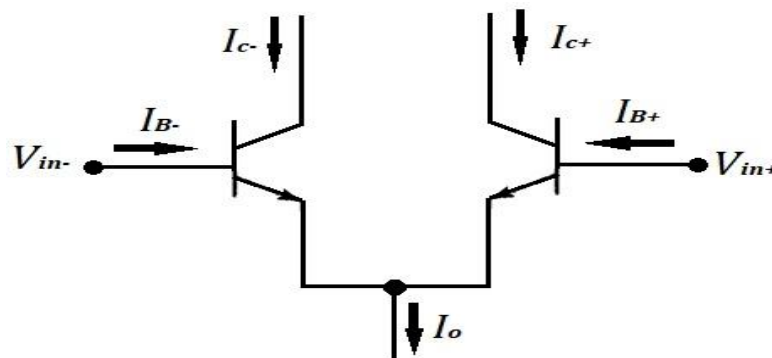

Figure 6: Bipolar Differential pair OTA

For bipolar OTAs, the transconductance (g_m) is given by;

$$g_m = \frac{I_B}{2V_T}$$

Where, $I_B =$ base current and $V_T =$ thermal equivalent voltage of transistor in kelvin.

- **MOS or CMOS OTA:** Most commonly used amplifier is CMOS-OTA. The CMOS-OTA is a voltage-controlled device. The operational transconductance amplifier (OTA) has a large numbers of applications in analog electronic circuits. It can be designed by using complementary metal oxide semiconductor (CMOS) technology. However, CMOS based technology scales down to the nano-meter range.

One of the finest advantage of CMOS-OTA is the transconductance (g_m) of CMOS-OTA is adjustable by the control-voltage(V_C). The circuit of a CMOS-OTA is shown in fig. 5.2.

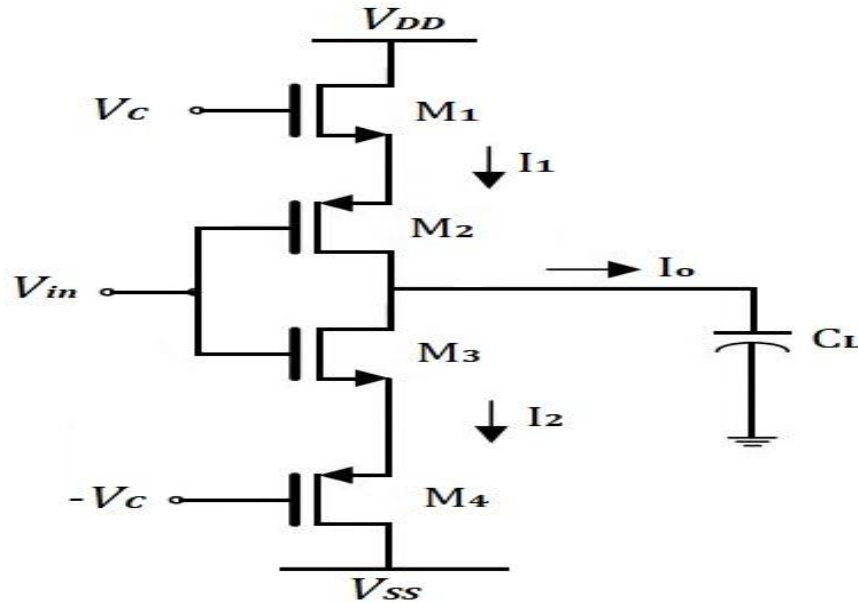

Figure 7: Single input single output CMOS-OTA

Circuit diagram of single input single output CMOS-OTA is presented in figure 7 Single input V_{in} is given and output current I_o is obtained.

Output current:
$$I_o = g_m V_{in}$$

Gain:
$$g_m = 2K (V_C - V_{th}) \tag{5.2}$$

Where, V_{th} is threshold voltage of n-channel MOS. One thing more we have to be noted that, from above equation 5.2, the g_m depends on V_C , so the g_m is adjustable by the control voltage V_C , therefore, a MOS-OTA is ultimately a voltage-controlled device. Such type of OTA has wide ranging of electronic tunability with control voltage (V_C).

5. Characteristics of OTA: As we know that the characteristics of ideal Op-Amp similarly the important characteristics of an ideal OTA summarized as follows:

- Infinite input impedance; $R_i = \infty$
- Infinite output impedance; $R_o = \infty$
- Infinite bandwidth; $\omega = \infty$
- Perfect balance; $I_o = 0$; when; $V_1 = V_2$
- Finite transconductance (g_m) and controllable by the amplifier bias current I_{bias} .

- 6. Application of OTA:** The main applications of transconductance amplifier, it is used in amplitude modulation in the communication system. An OTA can be used as a voltage controlled amplifier (VCA), voltage controlled filter (VCF), or voltage controlled oscillator (VCO). The total current consumption of OTA is simply the twice of the I_{bias} current (which is less than $0.1\mu A$), that's why operating the device can be used in micro power applications.