

AI-DRIVEN ADVANCEMENTS IN ROBOTICS

Abstract

Artificial Intelligence (AI) has emerged as a transformative force in the field of robotics, revolutionizing the capabilities of robotic systems across various industries. This abstract explores the profound impact of AI-driven advancements in robotics, unveiling the symbiotic relationship between AI and robotics and their potential to shape a futuristic landscape of automation and intelligent machines. The convergence of AI and robotics has unlocked unprecedented possibilities in automation, efficiency, and adaptability. Machine learning algorithms and deep neural networks have empowered robots to acquire new skills, adapt to dynamic environments, and make informed decisions, mirroring human-like cognitive abilities. From autonomous vehicles navigating complex terrains to industrial robots optimizing production processes, AI has elevated robotics to new heights, transcending traditional limitations. While AI-driven robotics brings forth remarkable advancements, it also raises ethical and societal considerations. The abstract sheds light on the importance of responsible AI deployment, addressing concerns of human displacement and potential biases in decision-making algorithms. AI-Driven Advancements in Robotics signify a groundbreaking transformation in technology, propelling society towards a more automated and intelligent future. However, fostering responsible AI implementation and embracing the cooperative potential of human-robot collaboration are crucial for realizing the true benefits of this symbiotic relationship. As we venture into uncharted territories of AI-empowered robotics, continuous research and thoughtful integration of these technologies will shape a promising and harmonious coexistence between humans and machines.

Authors

Thirumalai Rajan Shanmugavel
Department of Mechatronics
PSG Polytechnic College
Coimbatore, Tamil Nadu, India

Sujatha Devarajan
Department of Mechatronics
PSG Polytechnic College
Coimbatore, Tamil Nadu, India

Keywords: AI-driven advancements, Robotics, convergence, automation, efficiency, adaptability, Machine learning, deep neural networks, autonomous vehicles.

I. INTRODUCTION

In recent years, the fields of Artificial Intelligence (AI) and Robotics have witnessed a remarkable convergence, leading to a profound transformation in the capabilities and potential of robotic systems. The integration of AI-driven advancements in robotics has ushered in a new era of intelligent machines, offering unprecedented opportunities for automation, efficiency, and adaptability across various industries. This chapter explores the dynamic relationship between AI and robotics, shedding light on how AI-powered technologies are reshaping the landscape of robotics and revolutionizing the way we interact with machines. Advancements in AI, particularly in machine learning and deep neural networks, have endowed robots with the ability to learn, reason, and make informed decisions, mimicking human-like cognitive abilities. This newfound intelligence has paved the way for robots to tackle complex tasks that were once deemed beyond their reach. From autonomous vehicles navigating bustling city streets to humanoid robots assisting in healthcare settings, AI has transformed the realm of robotics from scripted operations to adaptive and dynamic interactions with the world.

The application domains for AI-driven robotics are vast and diverse. In industries such as manufacturing and logistics, AI-powered robots optimize processes, enabling greater precision, flexibility, and productivity. Collaborative robots, or cobots, work alongside humans in industrial settings, facilitating safer and more efficient production lines. Moreover, AI-empowered drones are revolutionizing the way we approach surveillance, search and rescue operations, and environmental monitoring. The chapter will delve into key applications of AI in robotics, exploring real-world use cases and success stories from various sectors. It will delve into the impact of AI-driven robotics in healthcare, where robots are assisting in surgeries, providing personalized patient care, and supporting rehabilitation efforts. Additionally, the chapter will explore how AI-driven robotics are addressing challenges in agriculture, performing tasks such as crop monitoring and precision farming.

Furthermore, the chapter will emphasize the symbiotic relationship between humans and AI-driven robots. Rather than posing a threat, robots can complement human skills and capabilities, creating opportunities for collaborative partnerships that enhance productivity and overall well-being. As the boundaries between human and machine blur, the chapter will reflect on how this cooperative potential can be harnessed to address societal challenges and create a better future for humanity. The advent of AI-Driven Advancements in Robotics represents a paradigm shift in the world of technology. As AI continues to advance, its integration with robotics will open up new possibilities; transform industries, and impact society on a global scale. This chapter aims to offer a comprehensive exploration of the symbiotic relationship between AI and robotics, providing insights into the transformative potential and ethical considerations associated with this rapidly evolving field.

II. SUPERVISED LEARNING FOR ROBOT CONTROL

1. Introduction to Supervised Learning in Robot Control: The applications of supervised learning in robot control are far-reaching and profound. From autonomous vehicles navigating intricate traffic scenarios to industrial robots performing precise assembly tasks, supervised learning empowers robots to adapt and excel in intricate and real-world situations. The technique finds resonance in various domains, including healthcare, manufacturing, agriculture, and even space exploration. In surgical robotics, for instance,

supervised learning enables robots to mimic the dexterity of skilled surgeons, enhancing the precision and safety of medical procedures. However, the journey from labeled data to proficient robot control is not without challenges. The process of data collection and annotation demands careful consideration, as high-quality labeled data is fundamental to the success of supervised learning. Moreover, supervised learning models are susceptible to over fitting, where they memorize training data rather than learning the underlying patterns. Balancing the trade-off between exploration and exploitation is essential to ensure that robots can generalize their learning to new and unseen situations.

The potential of supervised learning in robot control is being amplified by advancements in sensor technology, computational power, and the availability of large-scale datasets. Robots can now harness the power of deep neural networks, enabling them to extract intricate features from raw sensory data and perform complex control tasks with heightened accuracy. Supervised learning has ignited a paradigm shift in robot control, endowing robots with the ability to learn and adapt from data, much like humans do. The symbiotic relationship between supervised learning and robot control holds the promise of safer, more efficient, and more versatile robotic systems, enriching various sectors and contributing to the advancement of science and technology.

2. Applications of Supervised Learning in Robotic Systems: Supervised learning, a cornerstone of artificial intelligence, has found a multitude of applications within the realm of robotic systems, enhancing their capabilities and enabling them to perform tasks with precision and adaptability. This section delves into various domains where supervised learning is leveraged to empower robotic systems, ushering in new dimensions of automation, efficiency, and intelligence.

- **Autonomous Navigation and Path Planning:** In autonomous vehicles and drones, supervised learning assists in mapping sensory data (such as images and lidar scans) to safe navigation actions. Robots learn to maneuver through complex environments, avoiding obstacles and adhering to traffic rules. This application is pivotal for transportation, surveillance, and search-and-rescue missions.

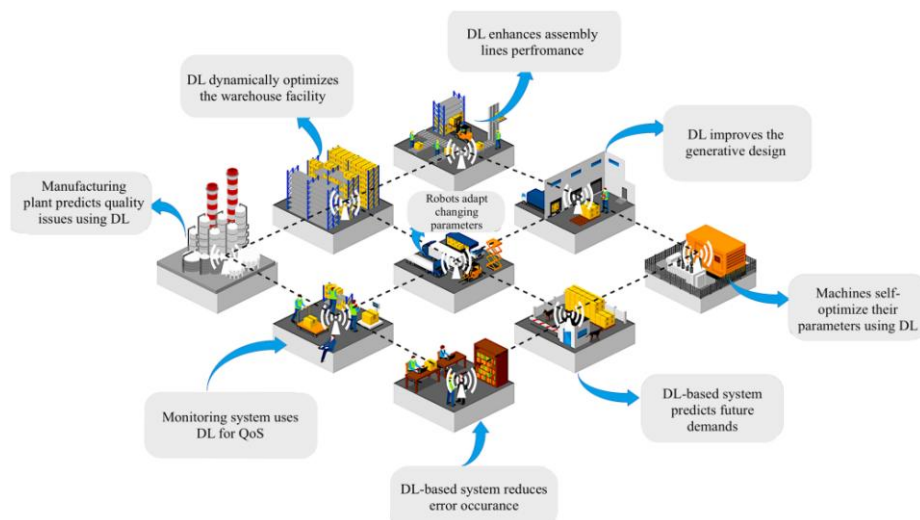

Figure 1: Machine Learning in Future Industrial Internet of Things

- **Industrial Automation and Manufacturing:** Supervised learning enables industrial robots to perform intricate tasks, such as assembly and quality control, by learning from annotated examples. These robots learn to precisely manipulate objects and optimize production processes, contributing to increased efficiency and reduced human intervention in manufacturing.
- **Healthcare and Medical Robotics:** Surgical robots benefit from supervised learning by learning from expert surgeons' movements and techniques. This facilitates precise and minimally invasive procedures, reducing patient risk and recovery times. Additionally, robotic exoskeletons and prosthetics employ supervised learning to mimic human motion and aid in rehabilitation.
- **Agriculture and Precision Farming:** Robots equipped with supervised learning can identify and categorize crops, pests, and diseases. They make informed decisions about pesticide application and crop harvesting, enhancing agricultural productivity and sustainability.



Figure 2: Deep Learning based Smart Hospital

- **Object Recognition and Manipulation:** Robots in logistics and warehousing use supervised learning to recognize and grasp objects of varying shapes and sizes. This technology streamlines supply chain operations and e-commerce fulfillment processes.
- **Environmental Monitoring and Exploration:** Supervised learning equips robots with the ability to analyze sensor data for environmental monitoring tasks, such as water quality assessment or wildlife tracking. In space exploration, robots learn to navigate and interact with extraterrestrial environments.



Figure 3: Deep Learning based Agricultural Monitoring

- **Human-Robot Interaction and Assistance:** Supervised learning enhances the communication and interaction between humans and robots. Robots can learn to understand and respond to human gestures, speech, and expressions, making them valuable companions for tasks like eldercare and customer service.
- **Security and Surveillance:** Supervised learning enhances robotic systems' ability to detect and respond to security threats. Robots can learn to identify suspicious behavior, monitor restricted areas, and enhance public safety.

III. REINFORCEMENT LEARNING FOR AUTONOMOUS ROBOTS

Autonomous robotics, with the ability to make informed decisions and navigate complex environments independently, has been a longstanding goal in the field of robotics. Reinforcement Learning (RL), a subfield of machine learning, has emerged as a transformative approach to achieving autonomy in robots. This section explores how reinforcement learning empowers robots to learn from their interactions with the environment, enabling them to acquire skills, optimize behaviors, and operate autonomously in dynamic and uncertain settings.

1. Fundamentals of Reinforcement Learning for Robot Control: Reinforcement Learning (RL) is a powerful framework within the field of machine learning that enables robots to learn how to make decisions and take actions in order to achieve specific goals. This section provides an overview of the fundamental concepts and components of reinforcement learning as applied to robot control, outlining the key elements that govern the learning process.

- **Agent and Environment:** In the context of reinforcement learning, the robot is referred to as the "agent," and the external surroundings with which the robot interacts constitute the "environment." The agent learns by taking actions within the environment, receiving feedback in the form of rewards or penalties based on the consequences of its actions.
- **State and Action Spaces:** The "state" of the environment encapsulates all the relevant information necessary for the agent to make decisions. The "action" represents the choices available to the agent in a given state. The agent's goal is to learn a policy—a mapping from states to actions—that maximizes the cumulative rewards it receives over time.

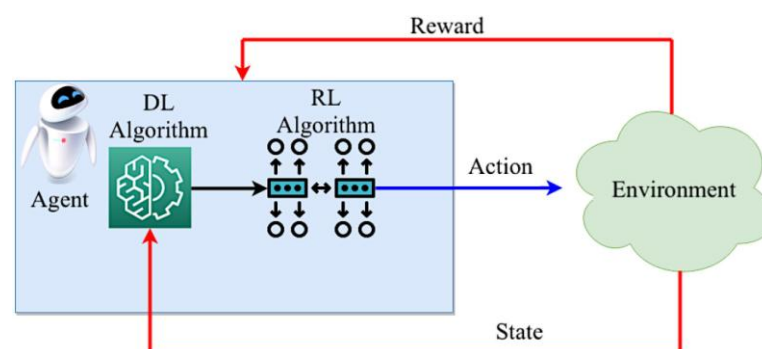

Figure 4: Deep Reinforcement Learning Model

- **Reward Signals:** At each time step, the agent receives a reward signal from the environment based on its chosen action and resulting state transition. The reward serves as a measure of the immediate benefit or cost associated with the action taken. The agent's objective is to learn a policy that maximizes the cumulative sum of rewards, often referred to as the "return".

2. Exploration-Exploitation Trade-Offs in Robotic Learning: Exploration and exploitation are fundamental concepts in the field of reinforcement learning, playing a critical role in guiding how robots learn and make decisions in dynamic and uncertain environments. The exploration-exploitation trade-off encapsulates the delicate balance between trying out new actions to gather information and leveraging known actions to maximize rewards. In robotic learning, this trade-off is essential for robots to effectively learn and adapt to their surroundings while achieving their goals. This section explores the exploration-exploitation trade-offs in the context of robotic learning and their implications for autonomous decision-making.

- **Exploration:** Exploration refers to the process by which a robot selects unfamiliar or uncertain actions to gather information about its environment and learn about potentially better strategies. It involves taking actions that may not have been extensively tried before, even if the short-term rewards are not optimal. Exploration is crucial for discovering hidden rewards, identifying optimal policies, and refining the robot's knowledge of the environment.
- **Exploitation:** Exploitation, on the other hand, involves selecting actions that are known to yield high rewards based on the robot's current knowledge. Exploitative actions aim to capitalize on the robot's existing understanding of the environment to maximize immediate returns. Exploitation is essential for robots to make efficient decisions and benefit from their learned knowledge.
- **Balancing Exploration and Exploitation:** The challenge lies in finding the right balance between exploration and exploitation. Purely exploiting known actions may lead to suboptimal long-term performance, as the robot may miss out on discovering potentially better strategies. Conversely, excessive exploration may result in spending too much time exploring irrelevant or unpromising actions, hindering the robot's ability to achieve its objectives efficiently.
- **Exploration Strategies:** Robotic learning employs various exploration strategies to strike the exploration-exploitation balance:
 - **Epsilon-Greedy:** The robot selects the action with the highest known reward most of the time (exploitation), but occasionally chooses a random action (exploration) to prevent overlooking better options.
 - **Upper Confidence Bound (UCB):** The robot chooses actions that balance the trade-off between known rewards and uncertainty, encouraging exploration of actions with higher potential.
 - **Thompson Sampling:** The robot maintains a probability distribution over the rewards for each action and samples from these distributions to guide its decision-making, promoting both exploration and exploitation.

IV. DEEP NEURAL NETWORKS FOR PERCEPTION AND DECISION MAKING

Deep Neural Networks (DNNs) have emerged as a transformative technology in the field of robotics, enabling robots to perceive and interact with their environments in ways that closely mimic human cognition. This section delves into the role of DNNs in enhancing perception and decision-making capabilities within robotic systems, highlighting their applications, advantages, and challenges.

1. Role of Deep Neural Networks in Robotic Perception: Deep Neural Networks (DNNs) have revolutionized the field of robotic perception by enabling machines to process, interpret, and extract meaningful information from sensory data, such as images, videos, audio, and sensor readings. DNNs have proven to be highly effective tools for enhancing the perceptual capabilities of robots, allowing them to understand their surroundings, identify objects, and make informed decisions based on the sensory input they receive. This section delves into the pivotal role that DNNs play in robotic perception and explores their applications, advantages, and impact on various domains.

- **Feature Extraction and Representation:** DNNs excel at automatically learning hierarchical features and representations from raw data. In robotic perception, DNNs extract intricate and relevant features from sensory inputs, enabling robots to capture essential patterns and characteristics. For instance, in image recognition tasks, DNNs automatically learn features such as edges, textures, and shapes that are crucial for identifying objects.
- **Object Detection and Localization:** DNNs have transformed object detection and localization in robotic perception. Convolutional Neural Networks (CNNs) are widely employed to accurately detect and locate objects within images or videos. This is pivotal in applications like autonomous driving, where robots need to identify pedestrians, vehicles, and road signs to navigate safely.
- **Semantic Segmentation:** DNNs facilitate semantic segmentation, a technique that assigns a semantic label to each pixel in an image, effectively dividing the image into different regions associated with different objects or classes. Semantic segmentation enables robots to understand the layout of a scene and distinguish between different objects, which is crucial for tasks such as robotic mapping and scene understanding.
- **Visual Recognition and Classification:** DNNs empower robots to recognize and classify objects, scenes, and patterns from visual data. This capability is vital in scenarios where robots need to identify specific objects or make decisions based on the content of their environment. DNNs can distinguish between various objects and categories with high accuracy, enabling robots to make informed decisions.
- **Sensor Fusion and Multimodal Perception:** Robots often integrate information from multiple sensors, such as cameras, lidar, and microphones, for a comprehensive perception of their environment. DNNs facilitate sensor fusion by processing and fusing data from different sources, allowing robots to create a holistic understanding of their surroundings and make more robust decisions.
- **Real-Time Processing:** DNNs can be optimized for real-time processing, enabling robots to analyze sensory data on the fly and respond swiftly to changing situations. This is crucial for applications such as autonomous navigation, where real-time perception and decision-making are essential for safe and efficient operation.

2. Neural Architecture Designs For Real-Time Robot Control: Designing neural architectures for real-time robot control is a crucial endeavor to enable robots to make fast, accurate, and efficient decisions in dynamic and unpredictable environments. The architecture of neural networks plays a pivotal role in determining how well a robot can process sensory inputs, perform complex computations, and execute actions in real-time. This section explores key considerations and design strategies for crafting neural architectures tailored to real-time robot control.

- **Low Latency and Efficient Processing:** Real-time robot control demands low-latency processing to ensure timely decision-making. Neural architectures need to be optimized for rapid inference, striking a balance between model complexity and computational efficiency. Techniques like quantization, model pruning, and lightweight network architectures (e.g., MobileNet, SqueezeNet) can help reduce the computational load while maintaining performance.
- **Parallelism and Hardware Acceleration:** To achieve real-time control, neural architectures can be designed to take advantage of parallel processing and hardware acceleration. Graphics Processing Units (GPUs), Field-Programmable Gate Arrays (FPGAs), and dedicated hardware accelerators can significantly speed up neural network computations, enabling robots to process sensory data and make decisions in milliseconds.
- **Recurrent Architectures for Temporal Processing:** Many real-time control tasks involve processing sequential data, such as sensor readings over time. Recurrent Neural Networks (RNNs) and Long Short-Term Memory (LSTM) networks are well-suited for capturing temporal dependencies and dynamics. These architectures can be used for tasks like gesture recognition, speech processing, and trajectory prediction.
- **Convolutional Architectures for Perception:** Convolutional Neural Networks (CNNs) are a cornerstone of visual perception in robotics. Architectures like ResNet, DenseNet, and EfficientNet are designed to extract hierarchical features from images, enabling robots to recognize objects, detect obstacles, and navigate complex environments.
- **Hybrid Architectures for Sensor Fusion:** Real-time robot control often involves fusing data from multiple sensors, such as cameras, lidar, and IMUs. Hybrid architectures that combine CNNs for visual perception with RNNs or attention mechanisms for sequential data can enable robots to process diverse sensory inputs and make cohesive decisions.

REFERENCES

- [1] Ruhul Amin Khalil , Member, IEEE, Nasir Saeed ,Senior Member, IEEE, Mudassir Masood, Yasaman Moradi Fard, Mohamed-Slim Alouini , Fellow, IEEE, and Tareq Y. Al-Naffouri , Senior Member, IEEE, “ Deep Learning in the Industrial Internet of Things: Potentials, Challenges, and Emerging Applications” IEEE Internet Of Things journal, vol. 8, no. 14, july 15, 2021
- [2] M. Boukens, A. Boukabou, and M. Chadli, “Robust adaptive neural network-based trajectory tracking control approach for nonholonomic electrically driven mobile robots,” *Robot. Autonom. Syst.*, vol. 92, pp. 30–40, Jun. 2017.
- [3] S. Levine, P. Pastor, A. Krizhevsky, J. Ibarz, and D. Quillen, “Learning hand-eye coordination for robotic grasping with deep learning and large- scale data collection,” *Int. J. Robot. Res.*, vol. 37, nos. 4–5, pp. 421–436, 2017.
- [4] R. Jeong et al., “Self-supervised Sim-to-real adaptation for visual robotic manipulation,” in *Proc. IEEE Int. Conf. Robot. Autom. (ICRA)*, May 2020, pp. 2718–2724.

- [5] Y. Deng, T. Zhang, G. Lou, X. Zheng, J. Jin, and Q.-L. Han, “Deep learning-based autonomous driving systems: A survey of attacks and defenses,” *IEEE Trans. Ind. Informat.*, vol. 17, no. 12, pp. 7897–7912, Dec. 2021.
- [6] N. Yadav, S. A. Ansar, and P. K. Chaurasia, “Review of attacks on connected and autonomous vehicles (CAV) and their existing solutions,” in *Proc. 10th Int. Conf. Rel., Infocom Technol. Optim. (Trends Future Directions) (ICRITO)*, Oct. 2022, pp. 1–6.
- [7] P. A. Lasota, T. Fong, and J. A. Shah, “A survey of methods for safe human-robot interaction,” *Found. Trends Robot.*, vol. 5, no. 3, pp. 261–349, 2017.
- [8] M. S. Mahdavejad, M. Rezvan, M. Barekatin, P. Adibi, P. Barnaghi, and A. P. Sheth, “Machine learning for Internet of Things data analysis: A survey,” *Digit. Comm. Netw.*, vol. 4, no. 3, pp. 161–175, 2018.
- [9] C.-H. Lee, J.-W. Lin, P.-H. Chen, and Y.-C. Chang, “Deep learning- constructed joint transmission-recognition for Internet of Things,” *IEEE Access*, vol. 7, pp. 76547–76561, 2019.
- [10] H. Qureshi, Y. Nakamura, Y. Yoshikawa, and H. Ishiguro, “Robot gains social intelligence through multimodal deep reinforcement learning,” in *Proc. IEEE-RAS 16th Int. Conf. Humanoid Robot.*, 2016, pp. 745–751.
- [11] P. Henderson, R. Islam, P. Bachman, J. Pineau, D. Precup, and D. Meger, “Deep reinforcement learning that matters,” in *Proc. AAAI Conf. Artif. Intell.*, 2018.
- [12] C.-M. Huang and B. Mutlu, “Anticipatory robot control for efficient human-robot collaboration,” in *Proc. 11th ACM/IEEE Int. Conf. Hum.-Robot. Int.*, 2016, pp. 83–90