

LPG GAS LEAKAGE DETECTOR USING ARDUINO UNO

Abstract

The LPG Gas Leakage Detector is a safety-focused Arduino project that uses gas sensors to detect LPG presence and trigger alarms and notifications. This low-cost solution improves safety in homes and workplaces by providing timely warnings, preventing accidents, and ensuring prompt corrective actions. By integrating gas sensors with an Arduino board, the system continuously monitors air quality for LPG gas presence, triggering alarm mechanisms like buzzers and LED indicators. The project can also be extended to send notifications to smartphones or other devices via wireless modules. This cost-effective solution contributes to preventing gas-related accidents and offers a proactive approach to gas leak detection, safeguarding lives and property.

Keywords: LPG leakage detector, MQ-6 gas sensor, Blynk smart smoke detector, Arduino board, gas-related accidents

Authors

Nayim A Dalawai

Faculty, Department of MME
MS Ramaiah University of Applied Science

Prathamraj P B

Faculty, Department of MME
MS Ramaiah University of Applied
Science

I. INTRODUCTION

The LPG Gas Leakage Detector Arduino project is a significant advancement in safety in residential and industrial settings. LPG, a flammable gas, is used in cooking, heating, and industrial processes. To mitigate risks, the project uses Arduino technology to create an innovative gas leak detection system. The system uses specialized gas sensors sensitive to LPG fumes, integrated with an Arduino board as the central processing unit. The system continuously monitors ambient air quality, detecting even small traces of LPG gas. When a leak is detected, the Arduino activates a multi-tiered alarm mechanism, including a loud sound alarm and illuminating LEDs as visual indicators.

The LPG Gas Leakage Detector Arduino project is a significant advancement in safety technology, providing early-warning systems for gas leaks. It enables remote monitoring and enables users to respond swiftly to potential hazards, even when not physically present. The combination of gas sensors, Arduino, and alarm mechanisms creates a comprehensive safety net, ensuring the well-being of lives and property preservation.

II. OBJECTIVES

- To develop an Arduino-based system for monitoring and alerting of LPG gas leaks.
- To detect LPG gas leaks swiftly and accurately.
- To enhance safety and user-friendly design.
- To enable wireless communication modules and alter the mechanism.

III. COMPONENTS

- Arduino UNO
- MQ-6 gas sensor
- 16×2 LCD module
- 10K potentiometer
- LEDs
- 220 ohms resistors
- Jumper wires
- breadboard
- USB cable

IV. CIRCUIT DIAGRAM

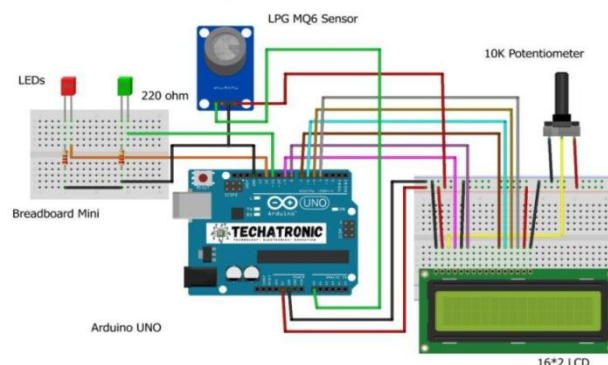

V. WORKING PROCEDURE

LPG gas leakage detection relies on specialized sensors designed to identify the presence of gas in the surrounding air. Typically installed in areas prone to gas leaks, such as kitchens or storage spaces, these sensors operate on semiconductor technology. When LPG gas is detected in the atmosphere, it triggers a change in the sensor's electrical conductivity. This alteration serves as an early warning system, alerting individuals to the potential danger of a gas leak, thus playing a crucial role in enhancing safety and preventing hazardous situations in homes and industrial settings.

VI. FLOWCHART

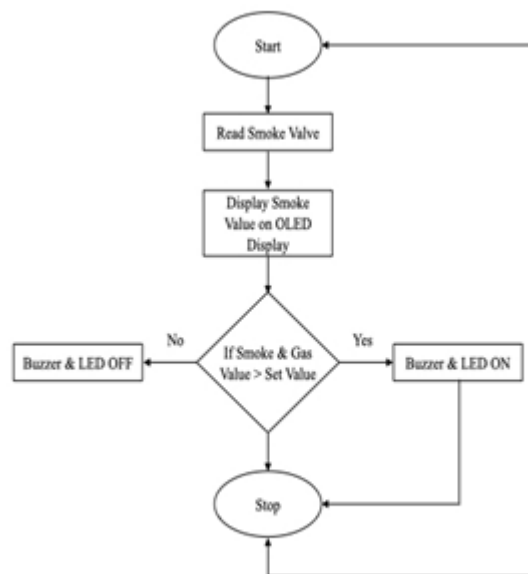

VII. RESULT

Investing in LPG gas as a fuel source significantly enhances house safety and industrial safety by preventing accidents and minimizing damage caused by gas leakage. Therefore, it represents a valuable and necessary investment. The use of LPG gas is not only efficient but also offers a crucial layer of safety in various applications, making it an essential choice for households and industries alike.



Figure 1: When LPG gas not detected



Figure 2: When LPG gas detected

VIII. CONCLUSION

The LPG Gas Leakage Detector Arduino project showcases the potential of technology in enhancing safety and mitigating hazards. Utilizing gas sensors, Arduino boards, and intelligent alarm mechanisms, the project creates a responsive and proactive gas leak detection system. Its meticulous design enables early warning, identifying even small traces of LPG gas, and enabling immediate preventive measures. The integration of sound alarms and LED indicators adds layers of awareness, ensuring prompt and effective alerting. The project's wireless communication capabilities make it a significant leap forward in safety solutions, allowing users to receive real-time notifications on smartphones, and empowering them with unparalleled control and oversight. This feature is especially critical in situations where timely intervention can avert disasters.

The LPG Gas Leakage Detector project not only safeguards lives but also emphasizes the importance of innovation in addressing real-world challenges. Its cost-effective approach ensures accessibility across diverse settings, contributing to safer homes, workplaces, and industrial environments. This project serves as a model for the amalgamation of technology and practicality, exemplifying the positive impact of creative engineering on society. As we continue to explore innovative ways to ensure safety and well-being, this project will inspire us to continue exploring innovative ways to ensure safety and well-being.

REFERENCE

- [1] Yan, H.H. and Rahayu, Y., 2014, August. Design and development of gas leakage monitoring system using arduino and zigbee. In 1st International Conference on Electrical Engineering, Computer Science and Informatics 2014. Institute of Advanced Engineering and Science.
- [2] Dewi, L. and Somantri, Y., 2018, July. Wireless sensor network on LPG gas leak detection and automatic gas regulator system using Arduino. In IOP Conference Series: Materials Science and Engineering (Vol. 384, No. 1, p. 012064). IOP Publishing.
- [3] Shahewaz, S.B. and Prasad, C.R., 2020. Gas leakage detection and alerting system using Arduino Uno. *Global Journal of Engineering and Technology Advances*, 5(3), pp.029-035.
- [4] Mujawar, T.H., Bachuwar, V.D., Kasbe, M.S., Shaligram, A.D. and Deshmukh, L.P., 2015. Development of wireless sensor network system for LPG gas leakage detection system. *International Journal of Scientific & Engineering Research*, 6(4), pp.558-563.
- [5] Leavline, E.J., Singh, D.A.A.G., Abinaya, B. and Deepika, H., 2017. LPG gas leakage detection and alert system. *International Journal of Electronics Engineering Research*, 9(7), pp.1095-1097.
- [6] Rajitha, S. and Swapna, T., 2012. A security alert system using GSM for gas leakage. *International Journal of VLSI and Embedded Systems-IJVES*, 3(04), pp.173-175.
- [7] Keshamoni, K. and Hemanth, S., 2017, January. Smart gas level monitoring, booking & gas leakage detector over IoT. In 2017 IEEE 7th international advance computing conference (IACC) (pp. 330-332). IEEE.