

# **AI-DRIVEN WOUND ASSESSMENT: LEVERAGING WEARABLE SENSORS FOR CLINICAL INNOVATION**

## **Abstract**

Wounds, whether chronic or acute, can significantly impair a patient's quality of life, limiting mobility and overall well-being. Traditional methods of assessing wounds rely heavily on subjective visual inspection by healthcare professionals, leading to inconsistencies and potential inaccuracies in the evaluation process. However, recent technological advancements have paved the way for automated wound assessment systems that harness the combined power of Internet of Things (IoT) sensors and Artificial Intelligence (AI). These data-driven systems hold immense promise in providing objective and standardized measurements, empowering healthcare providers to deliver personalized and optimized wound care tailored to each patient's needs. This chapter delves into the current landscape of wound assessment tools available to nurses responsible for managing both acute and chronic wounds. The chapter aims to identify the key functionalities an ideal wound assessment tool should possess through a comprehensive evaluation-based research approach, informed by an extensive analysis of existing literature. The evaluation goes beyond merely counting the number of physical factors considered by these tools; instead, it focuses on assessing the overall effectiveness of these solutions in providing accurate and actionable insights to healthcare professionals.

By understanding the strengths and limitations of currently available wound assessment tools, nurses and other healthcare providers can make informed decisions regarding the most appropriate treatment plans for their patients. This, in turn, can promote faster healing and better patient outcomes. The chapter emphasizes the importance of continuous improvement in wound assessment technologies, highlighting how the synergistic combination of IoT and AI can revolutionize wound care in the future. The current state of wound assessment is often marred by subjectivity and inconsistency, as traditional methods rely heavily on visual inspection and manual documentation. This approach is prone to human error

## **Authors**

### **Dr. Monica Bhutani**

Associate Professor  
Department of Electronics and  
Communication Engineering  
Bharati Vidyapeeth's College of  
Engineering,  
New Delhi, India

### **Dr. Jyoti Gupta**

Assistant Professor  
Department of Electronics and  
Communication Engineering  
Bharati Vidyapeeth's College of  
Engineering, New Delhi, India

### **Ms. Shikha**

Assistant Professor  
Department of Electronics and  
Communication Engineering  
Bharati Vidyapeeth's College of  
Engineering, New Delhi, India

### **Dr. Priyanka Gupta**

Assistant Professor  
Department of Electronics and  
Communication Engineering  
Bharati Vidyapeeth's College of  
Engineering, New Delhi, India

### **Ms. Neetu Setia**

Assistant Professor  
Department of Electronics and  
Communication Engineering,  
GTBIT, New Delhi, India

and can lead to inaccuracies in tracking the progression or regression of a wound over time.

Additionally, the subjective nature of these assessments can result in variations in the evaluation criteria used by different healthcare professionals, making it challenging to establish a standardized and objective baseline for comparison. IoT sensors, on the other hand, offer the potential for objective and quantitative data collection. By incorporating various sensor types, such as temperature, moisture, and imaging sensors, these devices can capture a wide range of wound characteristics with high precision. This data can then be fed into AI algorithms, which can analyze and interpret the information, providing healthcare professionals with accurate and actionable insights. AI algorithms can be trained on vast datasets of wound images and associated clinical data, enabling them to appear to human observers. These algorithms can also continuously learn and adapt as more data is fed into the system, improving their accuracy and recommendations over time. Additionally, AI can assist in predicting the likelihood of wound healing or complications, enabling proactive intervention and personalized treatment plans.

By combining the objective data collection capabilities of IoT sensors with the powerful analytical and predictive capabilities of AI, automated wound assessment systems can revolutionize wound care. These systems can provide standardized and objective measurements, mitigating the inconsistencies and subjectivity inherent in traditional methods. Furthermore, by leveraging AI-driven insights, healthcare professionals can optimize treatment plans, tailor interventions to individual patient needs, and ultimately improve patient outcomes. However, it is crucial to note that the successful implementation of these automated wound assessment systems requires a holistic approach that considers not only the technical aspects but also the practical considerations of integrating these technologies into existing healthcare workflows. Healthcare professionals must be trained to effectively interpret and utilize the insights provided by these systems, and data privacy and security measures must be implemented to protect patient information.

Furthermore, continuous improvement and refinement of these technologies are essential to ensure their long-term effectiveness and relevance. As new sensor technologies emerge and AI algorithms become more advanced, wound assessment systems must adapt and evolve to incorporate these advancements. Collaboration between healthcare professionals, technology providers, and researchers is paramount to driving innovation and addressing the evolving needs of wound care. In conclusion, the chapter underscores the growing potential of automated wound assessment systems that leverage the combined strengths of IoT sensors and AI. By providing objective and standardized measurements, these data-driven systems empower healthcare providers to deliver personalized and optimized wound care, ultimately improving patient outcomes and quality of life. As technology continues to advance, the synergy between IoT and AI holds immense promise in revolutionizing wound care practices, paving the way for more efficient, accurate, and effective wound management strategies.

**Keywords:** Internet of Things (IoT), Wearable Sensors, Edge Computing, Wireless Communication Protocols, MQTT Server, Cloud-Based Data Storage and Processing, Machine Learning (ML) Algorithms, Real-Time Monitoring, Data Security and Privacy, Low-Power Operation, Miniaturization, Interoperability

## **I. INTRODUCTION**

The human skin serves as a protective barrier, shielding the body from external threats and maintaining internal homeostasis. However, when this barrier is compromised due to injury or trauma, it results in a wound – a disruption of the skin's structural and functional integrity. Wounds can manifest in various forms, ranging from minor cuts and scratches to severe lacerations, punctures, or surgical incisions. Regardless of their severity, all wounds require proper assessment and treatment to promote healing and prevent complications. Wounds can occur due to a multitude of reasons, including accidents, surgical procedures, chronic conditions, or even intentional self-harm. Traumatic injuries, such as those sustained in falls, motor vehicle accidents, or workplace incidents, can lead to cuts, abrasions, or penetrating wounds. Surgical interventions, though intentional, also result in controlled wounds that require meticulous postoperative care. Chronic conditions like diabetes, vascular disorders, or pressure ulcers can also cause wounds that are slow to heal and require specialized attention.

The identification and assessment of wounds are crucial steps in the healing process. Healthcare professionals, particularly nurses and wound care specialists, play a vital role in this regard. Traditional wound assessment methods rely heavily on visual inspection, where the healthcare provider examines the wound's appearance, size, depth, and characteristics such as drainage, odor, and surrounding tissue condition. While visual assessment is an essential component, it is inherently subjective and prone to inconsistencies, as different healthcare professionals may interpret the same wound differently.

To address these limitations, the field of wound care has been increasingly embracing the integration of technology and data-driven approaches. The advent of Internet of Things (IoT) sensors and Artificial Intelligence (AI) has opened new avenues for objective and standardized wound assessment. IoT sensors can capture various wound parameters with high precision, including temperature, moisture levels, and high-resolution imaging. These sensors can be integrated into wound dressings, monitoring devices, or dedicated wound assessment platforms, providing continuous and real-time data collection. The data gathered by IoT sensors can then be analyzed and interpreted using AI algorithms. These algorithms can be trained on vast datasets of wound images and associated clinical data, enabling them to recognize patterns, classify wound types, and provide accurate assessments. AI can also assist in predicting the likelihood of wound healing or complications, enabling proactive intervention and personalized treatment plans.

One of the key advantages of automated wound assessment systems is their ability to provide objective and standardized measurements. Unlike traditional visual assessments, which are prone to subjectivity and inconsistencies, these data-driven systems rely on quantifiable parameters and advanced algorithms, reducing the potential for human error or bias. This objectivity is particularly valuable in scenarios where multiple healthcare professionals are involved in a patient's care, ensuring consistent and coordinated wound management. Moreover, automated wound assessment systems can support personalized and optimized wound care by considering a patient's unique factors, such as age, comorbidities, and medical history. AI algorithms can analyze these variables in conjunction with the wound data, providing tailored recommendations for treatment protocols, dressing selections, and follow-up schedules.

The integration of IoT and AI in wound assessment also has the potential to streamline healthcare workflows and reduce the administrative burden on healthcare professionals. Automated data collection and analysis can minimize manual documentation and calculations, allowing healthcare providers to focus their attention on direct patient care and optimizing treatment plans. While automated wound assessment systems offer significant advantages, it is crucial to address potential challenges and concerns. Data privacy and security are paramount when dealing with sensitive patient information and medical records. Robust measures must be implemented to ensure the confidentiality and integrity of patient data, adhering to relevant regulations and ethical guidelines.

Additionally, the successful adoption of these technologies requires a holistic approach that considers the needs and perspectives of both healthcare professionals and patients. Healthcare providers must be adequately trained to interpret and utilize the insights provided by automated wound assessment systems effectively. Patients, on the other hand, may have concerns regarding the use of technology in their care, and it is essential to address these concerns through education and open communication. Furthermore, continuous research and development are necessary to refine and enhance the capabilities of automated wound assessment systems. As new sensor technologies emerge and AI algorithms become more sophisticated, these systems must evolve to incorporate the latest advancements, ensuring their relevance and effectiveness in the ever-changing landscape of wound care.

Wounds are a significant concern in healthcare, impacting patients' quality of life and placing a substantial burden on healthcare systems. Traditional wound assessment methods, while valuable, are subject to subjectivity and inconsistencies. The integration of IoT sensors and AI in automated wound assessment systems offers a promising solution, providing objective and standardized measurements, enabling personalized and optimized wound care, and supporting more efficient healthcare workflows. However, the successful implementation of these technologies requires a comprehensive approach that addresses data privacy and security concerns, healthcare provider training, patient education, and continuous research and development. By embracing the synergy of IoT and AI in wound assessment, the healthcare industry can take a significant step forward in improving patient outcomes, reducing complications, and enhancing the overall quality of wound care. Wounds, whether acute or chronic, pose significant challenges in the healthcare domain, impacting patients' well-being and quality of life. Understanding the different types of wounds and their characteristics is crucial for healthcare professionals to provide effective treatment and promote healing. This document delves into the classification of wounds, exploring the distinctions between acute and chronic wounds, and highlighting the factors that contribute to their chronicity. Additionally, it emphasizes the importance of objective and standardized wound assessment methods, particularly through the utilization of wound imaging techniques.

In the realm of wound care, timely assessment and monitoring are crucial for ensuring optimal healing and preventing potential complications. Delayed or inadequate assessment of wounds can lead to further deterioration, prolonged recovery times, and increased healthcare costs. This research chapter aims to address this pressing issue by designing an innovative system that empowers patients and healthcare professionals to monitor and assess wounds in a timely and effective manner. The primary objective of this research is to develop a comprehensive solution that facilitates the continuous monitoring and assessment of various

physical parameters surrounding the wounded area. By continuously tracking factors such as temperature, humidity, and other relevant variables, the proposed system aims to provide real-time insights that can aid in the early detection of potential issues and guide appropriate interventions.

The novel contributions of this research chapter are twofold:

- a. Wireless Connectivity and Data Visualization:** The proposed system leverages the power of wireless connectivity to seamlessly transmit data from the wound monitoring device to the patient's or healthcare provider's smartphone. This approach enables real-time data visualization in the form of intuitive graphs, depicting the variation of temperature, humidity, or other relevant parameters over time. By presenting this information in a visually accessible manner, the system empowers users to quickly identify any concerning trends or deviations from expected healing patterns.
- b. Continuous Data Storage and Synchronization:** To ensure data integrity and uninterrupted monitoring, the system incorporates an EPROM (Erasable Programmable Read-Only Memory) module. This module stores the collected data, even in the event of a disrupted wireless connection. Once the connection is re-established, the stored data is seamlessly synchronized and appended to the existing graphs, providing a comprehensive historical record of the wound's progression.

## **II. TYPES OF WOUNDS**

Wounds can be broadly categorized into two main types: acute wounds and chronic wounds. Each type presents unique characteristics and requires specific approaches for effective management and treatment.

### **Acute Wounds**

An acute wound is a recent injury that has yet to progress through the different stages of the wound healing process. These wounds typically occur due to incisions or trauma, such as cuts, lacerations, or surgical procedures. Acute wounds have the potential to heal in a timely manner without significant complications when provided with proper treatment and care.

The healing process of acute wounds follows a well-defined sequence, progressing through the inflammatory, proliferative, and remodeling phases. During these stages, the body initiates a complex cascade of events involving clotting, inflammation, tissue repair, and scar formation. Acute wounds are generally treated with appropriate wound care techniques, such as cleaning, disinfection, and the application of dressings or bandages.

### **Chronic Wounds**

In contrast to acute wounds, chronic wounds are characterized by a failure to progress through the normal stages of wound healing in a timely and orderly manner. These wounds often show no significant improvement even after 30 days of treatment and management.

Chronic wounds can be challenging to treat and may require specialized interventions to address the underlying factors contributing to their chronicity.

Several factors can contribute to the development and persistence of chronic wounds, including:

- 1. Pressure and Trauma:** Prolonged exposure to pressure or repeated trauma can impede the healing process and lead to the formation of chronic wounds, such as pressure ulcers or diabetic foot ulcers.
- 2. Increased Infection and Bacterial Load:** High levels of bacterial colonization or infection can disrupt the wound healing process and prevent the wound from progressing through the normal stages of healing.
- 3. Underlying Diseases:** Certain medical conditions, such as diabetes, vascular disorders, or immunodeficiency's, can impair the body's ability to heal wounds effectively, leading to chronic wound formation.
- 4. Inadequate Treatment and Irregular Monitoring:** Improper wound care practices, including insufficient debridement, inappropriate dressing selection, or inadequate monitoring of wound progress, can contribute to the chronicity of wounds.
- 5. Presence of Aberrant or Senescent Cells:** In some cases, the presence of abnormal or aging cells within the wound bed can interfere with the normal healing process, hindering tissue repair and regeneration.
- 6. Manual wound analysis presents significant challenges,** as it relies heavily on individual subjective assessments, which can often lead to inconsistent and varying results. Recognizing this limitation, the field of wound care has increasingly embraced the potential of wound imaging techniques, which offer a more objective and standardized approach to wound assessment.

### III. WOUND ASSESSMENT METHODS

**Contact Methods:** Contact methods involve direct interaction with the wound, either through physical contact or the application of specialized sensors or devices. These methods can provide detailed information about the wound's characteristics but may also carry risks of contamination or discomfort for the patient. Examples of contact methods include:

- a. Wound Tracings:** Physical tracing of the wound's perimeter using specialized tools or transparent films can provide accurate measurements of wound dimensions and area.
- b. Wound Fluid Analysis:** Collecting and analyzing wound exudate or fluid can provide valuable insights into the wound's biochemical environment, including pH levels, bacterial load, and the presence of specific biomarkers.
- c. Tissue Biopsy:** In some cases, a small tissue sample may be collected from the wound bed for further analysis, such as assessing cellular activity or identifying potential infections.

**Non-Contact Methods:** Non-contact methods leverage various imaging technologies to assess wounds without direct physical contact, reducing the risks of contamination and discomfort for the patient. These techniques offer a non-invasive approach to wound assessment and can provide valuable data for monitoring and treatment planning. Examples

of non-contact methods include:

- a. Digital Photography:** Capturing high-resolution digital images of wounds can provide detailed visual information about their appearance, size, and characteristics. Digital photography allows for consistent and standardized documentation, enabling longitudinal monitoring and comparison over time.
- b. Thermography:** Thermal imaging techniques can detect and visualize temperature variations within the wound and surrounding tissue, which can provide insights into the presence of inflammation, infection, or vascular complications.
- c. Hyperspectral Imaging:** This advanced imaging technique utilizes a broad range of the electromagnetic spectrum, beyond the visible light range, to capture detailed information about the wound's biochemical composition and tissue oxygenation levels.
- d. Three-Dimensional (3D) Imaging:** Various 3D imaging techniques, such as structured light scanning or photogrammetry, can generate accurate three-dimensional representations of wounds, providing valuable information about depth, volume, and topography.

The integration of wound imaging techniques with artificial intelligence (AI) and machine learning algorithms has further enhanced the objectivity and accuracy of wound assessment. AI-powered systems can analyze and interpret wound images, identifying patterns, classifying wound types, and providing quantitative measurements of wound characteristics. This data-driven approach can support healthcare professionals in making informed decisions regarding treatment plans, dressing selections, and monitoring wound progression.

Moreover, wound imaging techniques offer several advantages over traditional manual assessment methods. They provide a standardized and reproducible approach to wound evaluation, reducing the potential for subjective biases or inconsistencies. Digital records of wound images can be easily shared among healthcare professionals, facilitating collaboration and continuity of care. Additionally, these techniques enable longitudinal monitoring and comparison, allowing healthcare providers to track wound progression or regression over time accurately. It is important to note that while wound imaging techniques offer significant benefits, they should be used in conjunction with other clinical assessments and patient history. Healthcare professionals must carefully consider factors such as wound etiology, patient comorbidities, and overall health status when developing comprehensive treatment plans.

In conclusion, understanding the different types of wounds and their characteristics is essential for effective wound management. Acute wounds require timely intervention and appropriate wound care techniques, while chronic wounds often present complex challenges and may necessitate specialized treatments. The utilization of wound imaging techniques, combined with the power of AI and machine learning, offers a promising approach to objective and standardized wound assessment. By leveraging these technologies, healthcare professionals can gain valuable insights, monitor wound progression accurately, and develop personalized treatment plans tailored to each patient's unique needs. However, it is crucial to recognize that wound imaging should be integrated with comprehensive clinical assessments and patient-centered care to achieve optimal healing outcomes.



In the field of wound care, accurate and consistent assessment is paramount for ensuring optimal healing outcomes and preventing complications. Traditional methods of wound assessment, which heavily rely on subjective visual inspection and manual measurements, are prone to inter-observer variability and subjective interpretation. This lack of standardization can lead to inconsistencies in wound documentation, hampering effective monitoring and treatment planning. Recognizing these limitations, there has been a growing interest in developing advanced wound assessment systems that can be seamlessly integrated into the patient's care routine. These systems leverage cutting-edge technologies to provide continuous and objective tracking of the wound's healing status, offering valuable insights to healthcare professionals and empowering them to make informed decisions. To address the challenges faced by current wound assessment practices, a comprehensive review of existing research and tools has been conducted. This review aimed to identify the maximum possible challenges that present schemes face and explore implementable and feasible means to assess wounds accurately and provide the required results.

The following table summarizes the various research chapters studied and their respective approaches:

**Table 1: Related Research Work**

<b>Reference</b>	<b>Journal Name and Year</b>	<b>Novelty</b>
Multifunctional Dressing for Wound Diagnosis and Rehabilitation	Journal of Polymer Science, 2022	To discuss the creation of intelligent wound dressings, their integration with wearable sensors and medication delivery systems, and their use in anything from wound monitoring to timely therapeutic application.
An IoT-Based Intelligent Wound Monitoring System	IEEE Access, 2019	Making an IoT-based intelligent wound evaluation system, reading real-time wound internal and external variables, and interpreting the state of the wound based on measured factor values
Flexible integrated sensing platform for monitoring wound temperature	Microbial biotechnology, 2021	To develop a flexible integrated sensing platform that can track the local temperature of wounds in real-time using a smartphone app that has been specially designed.
Smart Flexible Electronics-Integrated Wound Dressing for Real-Time Monitoring and On-Demand Treatment of Infected Wounds	Advanced Science, 2020	To construct a smart, flexible gadget that can release antibiotics on demand after being UV-triggered to diagnose infections at an early stage. Data from the sensor is transmitted over Bluetooth to a smartphone.

Battery-Free and Wireless Smart Wound Dressing for Wound Infection monitoring and electrically controlled on demand drug delivery	Advanced Functional Materials, 2021	To develop an NFC-based device that senses the psychological aspects of a Wound and electrically delivers an antibacterial medication when necessary. The device's battery life is decreased by the smartphone and its miniature circuitry.
---	-------------------------------------	---

Through this extensive review process, several key findings and insights have emerged:

One of the fundamental aspects of advanced wound assessment systems is their reliance on objective data collection methods. Traditional visual inspections, while valuable, are inherently subjective and prone to inconsistencies among different observers. To overcome this limitation, these innovative systems leverage a range of technologies, including sensors, imaging modalities, and computerized algorithms. By capturing quantifiable data points, such as temperature, moisture levels, wound dimensions, and tissue characteristics, these systems minimize the subjectivity inherent in manual assessments. The data collected through these objective methods is not only reproducible but also provides a solid foundation for analysis and informed decision-making.

Continuous monitoring is another key feature of many proposed wound assessment systems. Rather than relying on periodic evaluations, these systems offer real-time tracking of wound progression, enabling healthcare professionals to closely monitor the healing process. By continuously collecting and analyzing data, these systems can detect potential complications or deviations from expected healing patterns at an early stage. This early detection capability is crucial, as it allows for timely interventions and adjustments to treatment plans, potentially preventing further deterioration and improving overall outcomes.

The integration of wound assessment systems with remote monitoring and telemedicine platforms is a significant area of exploration in recent research efforts. These integrated solutions facilitate remote assessment of wounds by healthcare professionals, reducing the need for frequent in-person visits. This not only enhances patient convenience but also expands access to specialized wound care expertise, particularly in underserved or remote areas. By leveraging telemedicine technologies, healthcare providers can remotely evaluate wound data, provide consultations, and adjust treatment plans as needed, ensuring continuity of care and efficient resource utilization.

Artificial intelligence (AI) and machine learning algorithms have emerged as powerful tools in the field of advanced wound assessment. Several research chapters have explored the application of these technologies to analyze vast amounts of wound data, identify patterns, and provide predictive insights. By leveraging AI and machine learning, wound assessment systems can support data-driven decision-making and enable the development of personalized treatment plans tailored to individual patient needs. These algorithms have the potential to uncover complex relationships and trends that may not be evident through traditional analytical methods, ultimately enhancing the accuracy and precision of wound care interventions.

While these research efforts have made significant strides in advancing wound assessment practices, several challenges remain. These include ensuring data privacy and security, addressing technology adoption barriers, and establishing standardized protocols for integrating these systems into existing healthcare workflows. To overcome these challenges and bring the benefits of advanced wound assessment systems to clinical practice, a collaborative effort among researchers, healthcare professionals, technology providers, and policymakers is essential. By fostering interdisciplinary collaboration and leveraging the expertise of diverse stakeholders, innovative solutions can be developed, tested, and implemented in a manner that maximizes patient outcomes and optimizes resource utilization.

Ultimately, these research efforts aim to revolutionize wound care by providing healthcare professionals with accurate, real-time, and personalized insights into wound healing, enabling them to make informed decisions and deliver tailored interventions. By embracing the power of technology and evidence-based practices, the healthcare community can pave the way for improved patient experiences, reduced healthcare costs, and ultimately, better quality of life for those affected by wounds.

#### **IV. CHALLENGES WHILE ASSESSING THE WOUND**

Wound assessment is a critical component of wound management, as it provides valuable insights into the wound's condition, healing progress, and potential complications. However, healthcare professionals, particularly nurses, often face various challenges while assessing and treating wounds. These challenges have led to the adoption of a holistic and systematic approach, which involves comprehensive wound assessment at the initial and ongoing phases of treatment. This approach serves several purposes: establishing baseline information against which progress can be monitored, selecting suitable dressings, and implementing appropriate measures for wound care. Inadequate or inaccurate wound assessment can have severe consequences for the patient's well-being. Improper diagnosis or misinterpretation of wound characteristics can compromise the course of treatment, delay recovery, and potentially lead to significant complications. Therefore, employing the best possible assessment methods is crucial to ensure adequate treatment and should be an integral part of wound care practices.

Wound assessment and pre- and post-wound treatment care can be challenging for nurses for many reasons, some of which are discussed below:

- a. Complexity of the wound Healing Process:** Wound healing is a complex biological process, involving intricate mechanisms and numerous factors that influence its progression. Even for experienced healthcare professionals, assessing and managing wounds, particularly chronic wounds, can be difficult because the typical healing trajectory is often not followed. Understanding the intricacies of wound healing, including the phases of inflammation, proliferation, and remodelling, is essential for accurate assessment and effective treatment planning.
- b. Influence of Environmental Factors:** Various environmental factors can significantly impact wound healing. Factors such as moisture levels, mechanical stress or strain, temperature, and pH of the wound bed play crucial roles in the healing process. Any fluctuations or imbalances in these parameters can delay healing or even lead to further complications. Assessing and maintaining an optimal wound environment is a

challenging task that requires careful monitoring and appropriate interventions.

- c. **Patient-Specific Factors:** Individual patient characteristics and underlying health conditions can greatly influence wound healing. Patients with co morbidities like diabetes, cancer, or immunodeficiency's often experience delayed healing or increased susceptibility to complications. Assessing and considering these patient-specific factors is essential for developing personalized treatment plans and providing appropriate care.
- d. **Wound Assessment Subjectivity:** Traditional wound assessment methods, such as visual inspection and manual measurements, are inherently subjective and prone to variability among healthcare professionals. Different assessors may interpret wound characteristics differently, leading to inconsistencies in assessment and treatment decisions. This subjectivity can be compounded by factors such as lighting conditions, experience level, and individual biases.
- e. **Wound Documentation and Communication:** Accurate and consistent documentation of wound assessments is crucial for monitoring progress, facilitating interdisciplinary communication, and ensuring continuity of care. However, maintaining comprehensive and standardized documentation can be challenging, especially in busy healthcare settings or when multiple providers are involved in a patient's care.
- f. **Access to Advanced Assessment Tools:** While technological advancements have introduced various wound assessment tools and imaging modalities, access to these resources can be limited in certain healthcare settings or geographic regions. Financial constraints, lack of training, or institutional policies may hinder the adoption of advanced wound assessment methods, potentially compromising the quality of care.

## V. STATE-OF-THE-ART TECHNIQUES

A multifaceted approach is necessary to address the challenges mentioned in the last section and improve wound assessment practices. Here are some strategies that can be implemented:

- a. **Standardized Assessment Protocols:** Developing and implementing standardized wound assessment protocols can help reduce subjectivity and ensure consistency in evaluating wound characteristics. These protocols should include guidelines for assessing factors such as wound size, depth, tissue type, exudate, odor, and surrounding skin condition. By following a structured approach, healthcare professionals can minimize variability and facilitate accurate documentation and communication.
- b. **Interdisciplinary Collaboration:** Wound assessment and management often require input from various healthcare disciplines, including nurses, physicians, wound care specialists, and physical therapists. Fostering interdisciplinary collaboration and communication can ensure that different perspectives and expertise are integrated into the assessment process, leading to more comprehensive and informed treatment decisions.
- c. **Ongoing Education and Training:** Continuous education and training programs are essential for healthcare professionals to stay updated on the latest developments in wound assessment techniques, evidence-based practices, and emerging technologies. Regular training sessions can enhance knowledge and skills, promote consistent application of assessment methods, and ultimately improve patient outcomes.
- d. **Integration of Advanced wound Assessment Technologies:** Embracing advanced wound assessment technologies, such as digital imaging, thermography, hyperspectral imaging, and three-dimensional (3D) scanning, can provide objective and quantifiable data for wound evaluation. These technologies can minimize subjectivity, enable longitudinal monitoring, and support data-driven decision-making. However, their

implementation should be accompanied by adequate training and resource allocation.

- e. **Telemedicine and Remote Wound Monitoring:** Leveraging telemedicine and remote wound monitoring solutions can facilitate access to specialized wound care expertise, even in remote or underserved areas. Through secure digital platforms, healthcare professionals can share wound images and data, enabling remote assessment and consultation with wound care specialists, promoting timely interventions, and enhancing continuity of care.
- f. **Patient Education and Engagement:** Involving patients and their caregivers in the wound assessment process can enhance understanding and adherence to treatment plans. Providing education on wound care, self-monitoring techniques, and recognizing signs of complications can empower patients to actively participate in their healing journey and promptly report any concerns or changes to their healthcare providers.
- g. **Evidence-Based Practice and Guidelines:** Adhering to evidence-based practice guidelines and clinical decision support tools can help ensure that wound assessment and management strategies are grounded in the latest scientific research and best practices. Regular updates to these guidelines, incorporating emerging evidence and treatment modalities, can support consistent and effective wound care delivery.
- h. **Quality Improvement Initiatives:** Implementing quality improvement initiatives focused on wound assessment practices can drive continuous improvement and enhance patient outcomes. These initiatives may involve auditing current processes, analyzing data on wound healing rates, and identifying areas for improvement. Involving multidisciplinary teams in these efforts can foster a culture of continuous learning and promote sustainable improvements in wound care delivery.

Overcoming the challenges in wound assessment requires a concerted effort from healthcare organizations, professionals, and stakeholders. By addressing these challenges through a comprehensive and multifaceted approach, healthcare providers can enhance the accuracy and consistency of wound assessments, facilitate effective communication and collaboration, and ultimately deliver better outcomes for patients with acute or chronic wounds.

## **VI. PROPOSED METHODOLOGY**

Wound care is a critical aspect of healthcare, and monitoring the wound's condition plays a crucial role in ensuring proper healing and preventing complications. In this proposed system, we aim to revolutionize the way wounds are assessed and monitored by leveraging cutting-edge sensor technology and data analytics. The primary objective is to collect various physical data points, including temperature, humidity, strain, and pressure, to gain comprehensive insights into the wound's condition.

The system is designed to monitor a wide range of wounds, such as surgical wounds, pressure ulcers, diabetic foot ulcers, burns, and other injuries that require regular monitoring. By continuously tracking these physical parameters, healthcare professionals can make informed decisions and implement timely interventions, ultimately improving patient outcomes and accelerating the healing process.

At the core of the proposed system is a sophisticated sensor array that incorporates several specialized sensors:

- a. **SHT20 Sensor:** This highly accurate sensor is responsible for measuring the temperature and humidity levels in the immediate vicinity of the wounded area. Temperature and humidity play crucial roles in wound healing, as deviations from optimal levels can promote bacterial growth, disrupt the healing process, and increase the risk of complications.
- b. **DF350 Strain Gauge Sensor:** Monitoring strain is essential for wounds that are susceptible to mechanical stress or pressure, such as pressure ulcers or diabetic foot ulcers. The DF350 strain gauge sensor accurately measures the strain exerted on the wounded area, providing valuable insights into potential risk factors that could impede healing.
- c. **RP-S40-ST FSR (Force Sensitive Resistor):** This sensor is designed to measure the pressure applied to the wounded area. Excessive pressure can disrupt blood flow and oxygen supply, hampering the healing process. By continuously monitoring pressure levels, the system can alert healthcare professionals to potential issues, allowing them to take appropriate measures to alleviate pressure and promote optimal healing conditions.

The data collected from these sensors is transmitted to a microcontroller, which acts as the central processing unit of the system. The microcontroller is responsible for processing the raw sensor data, performing necessary calculations, and preparing the data for transmission to a cloud-based platform. The proposed system leverages the power of the Internet of Things (IoT) by establishing a wireless connection between the microcontroller and a mobile device, such as a smartphone or tablet. This connection enables real-time data transmission from the sensor array to the cloud-based platform, where the data is stored, processed, and visualized.

The cloud-based platform used in this system is ThingsBoard, a powerful open-source IoT platform that offers robust data management, visualization, and analytics capabilities. Once the data is received from the microcontroller, it is visualized on a custom app as live graphs, providing healthcare professionals with a clear and concise representation of the wound's condition. One of the key advantages of this system is its ability to store data not only in the cloud but also locally on the microcontroller's EPROM (Erasable Programmable Read-Only Memory). This redundant data storage approach ensures that even in the event of a disrupted wireless connection, the collected data remains safe and secure. Once the connection is re-established, the stored data is seamlessly synchronized and appended to the existing graphs, providing a comprehensive historical record of the wound's progression.

The combination of real-time data visualization and historical data analysis enables healthcare professionals to identify patterns, detect anomalies, and make informed decisions regarding treatment plans. For instance, if the system detects a sudden spike in temperature or a sustained increase in pressure, it can trigger alerts or notifications, prompting healthcare professionals to investigate and intervene promptly. Furthermore, the collected data can be analyzed using advanced machine learning algorithms and predictive models, allowing for the identification of potential risk factors and the prediction of healing outcomes. This data-driven approach not only supports personalized treatment plans but also contributes to advancing research in wound care and improving overall healthcare practices.

To ensure the system's usability and accessibility, a user-friendly interface will be developed, allowing healthcare professionals and patients to easily access and interpret the

collected data. Additionally, educational resources and training materials will be provided to empower patients and caregivers in self-monitoring and understanding the significance of the various physical parameters being tracked. It is important to note that while this proposed system offers numerous advantages, it is not intended to replace the expertise and clinical judgment of healthcare professionals. Instead, it serves as a powerful tool to augment their decision-making process by providing objective, real-time, and comprehensive data about the wound's condition. Furthermore, the implementation of this system must address critical considerations such as data privacy and security. As the system handles sensitive patient information, robust measures must be implemented to ensure compliance with relevant regulations and protect patient confidentiality. This may include secure data encryption, access control mechanisms, and rigorous data handling protocols.

To summarize, the proposed wound monitoring system leverages advanced sensor technology, cloud computing, and data analytics to revolutionize the way wounds are assessed and monitored. By continuously collecting and analyzing physical data points such as temperature, humidity, strain, and pressure, the system provides healthcare professionals with comprehensive insights into the wound's condition. This data-driven approach enables early detection of potential complications, supports personalized treatment plans, and ultimately contributes to improved patient outcomes and accelerated healing. While addressing important considerations such as data privacy and security, this system has the potential to transform wound care practices, paving the way for more efficient, effective, and patient-centric healthcare solutions.

## VII. SYSTEM DESCRIPTION

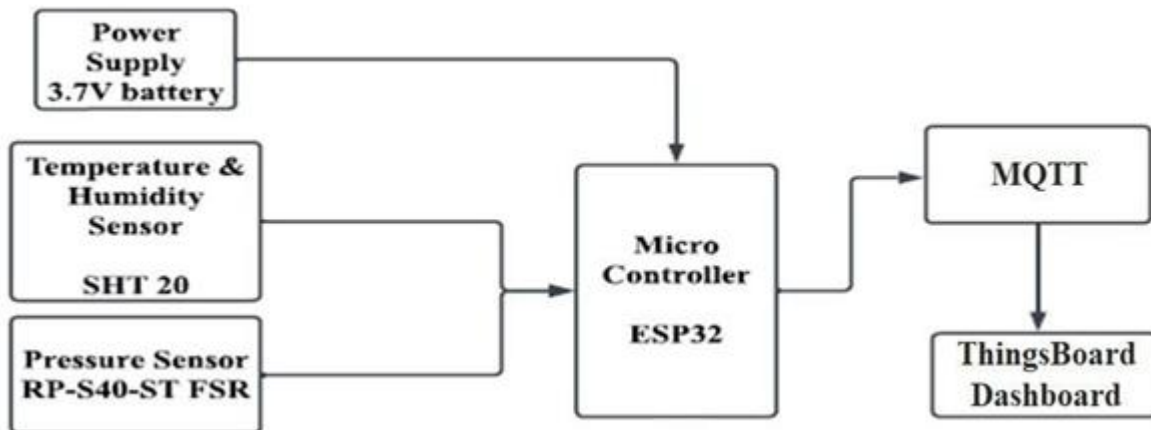

**Figure 1:** Block Diagram of Wound Assessment System

The proposed wound monitoring system is a synergistic combination of advanced hardware components and sophisticated software implementations, working together to provide comprehensive and reliable wound assessment capabilities. The seamless integration of these two aspects is crucial for ensuring the system's efficiency, accuracy, and user-friendliness.

## 1. Hardware Implementation

At the heart of the hardware implementation lies a carefully selected array of sensors, each designed to capture specific physical parameters vital for monitoring the wound's condition. These sensors include:

- **SHT20 Sensor:** This highly accurate and reliable sensor is responsible for measuring temperature and humidity levels in the immediate vicinity of the wounded area. Temperature and humidity play crucial roles in the healing process, and any deviations from optimal levels can significantly impact the wound's progression.
- **DF350 Strain Gauge Sensor:** Monitoring strain is essential for wounds that are susceptible to mechanical stress or pressure, such as pressure ulcers or diabetic foot ulcers. The DF350 strain gauge sensor accurately measures the strain exerted on the wounded area, providing valuable insights into potential risk factors that could impede healing.
- **RP-S40-ST FSR (Force Sensitive Resistor):** This sensor is designed to measure the pressure applied to the wounded area. Excessive pressure can disrupt blood flow and oxygen supply, hampering the healing process. By continuously monitoring pressure levels, the system can alert healthcare professionals to potential issues, allowing them to take appropriate measures to alleviate pressure and promote optimal healing conditions.

These sensors are strategically interfaced with the ESP32-C3 MINI-1, a powerful and versatile microcontroller that acts as the central processing unit of the system. The microcontroller is responsible for collecting and processing the raw sensor data, performing necessary calculations, and preparing the data for transmission to a cloud-based platform.

To ensure a compact and efficient design, the hardware implementation leverages the capabilities of PCB (Printed Circuit Board) design. Using industry-standard software like Eagle, the sensors and microcontroller are integrated onto a single PCB board. This approach not only reduces the system's complexity and size but also facilitates easier interfacing and maintainability.

## 2. Software Implementation

The software implementation plays a crucial role in ensuring the seamless operation and data management of the proposed wound monitoring system. The code for the microcontroller is meticulously developed using the Arduino Integrated Development Environment (IDE), which provides a user-friendly and powerful platform for programming the ESP32-C3 MINI-1 microcontroller. One of the key components of the software implementation is the integration of Wi-Fi and MQTT (Message Queuing Telemetry Transport) protocols. The Wi-Fi Manager module is responsible for establishing a reliable wireless connection between the microcontroller and a mobile device or gateway, enabling real-time data transmission. The MQTT protocol, on the other hand, facilitates efficient and secure communication between the microcontroller and the cloud-based platform. MQTT is a lightweight messaging protocol designed specifically for Internet of Things (IoT) applications, ensuring reliable and scalable data transfer even in environments with limited bandwidth or unstable network conditions.



The software implementation follows a well-defined sequence of operations:

- **Initialization:** Upon powering up the system, the microcontroller initiates the Wi-Fi network and checks for the connectivity of the sensors. It also verifies the establishment of sender and receiver connections via the Wi-Fi network.
- **Data Acquisition:** Once the connections are established, the microcontroller begins reading data from the sensors. It collects temperature, humidity, strain, and pressure measurements, ensuring accurate and reliable data capture.
- **Data Transmission:** The acquired sensor data is then formatted and transmitted to an MQTT broker, which acts as an intermediary between the microcontroller and the cloud-based platform. The MQTT broker ensures reliable and efficient data delivery, even in the presence of network disruptions or intermittent connectivity.
- **Data Visualization and Storage:** The MQTT broker forwards the received data to the ThingsBoard server, a powerful open-source IoT platform. Things Board is responsible for data visualization, storage, and analytics. The collected data is visualized on a custom app as live graphs, providing healthcare professionals with a clear and concise representation of the wound's condition. Simultaneously, the data is stored in a secure database, enabling historical analysis and trend identification.

One of the key advantages of the software implementation is its ability to store data not only in the cloud but also locally on the microcontroller's EPROM (Erasable Programmable Read-Only Memory). This redundant data storage approach ensures that even in the event of a disrupted wireless connection, the collected data remains safe and secure. Once the connection is re-established, the stored data is seamlessly synchronized and appended to the existing graphs, providing a comprehensive historical record of the wound's progression. In a system that handles sensitive patient information, data privacy and security are of utmost importance. The software implementation incorporates robust security measures to ensure compliance with relevant regulations and protect patient confidentiality. These measures may include secure data encryption, access control mechanisms, and rigorous data handling protocols.

Additionally, the system's user interface is designed with a strong emphasis on usability and accessibility. Healthcare professionals and patients can easily access and interpret the collected data through a user-friendly interface. Educational resources and training materials are provided to empower patients and caregivers in self-monitoring and understanding the significance of the various physical parameters being tracked. The software implementation is designed with scalability and continuous improvement in mind. As new sensor technologies emerge or additional parameters become relevant for wound monitoring, the system can be easily expanded and updated to incorporate these advancements. This scalability ensures that the proposed system remains at the forefront of wound care practices, adapting to the ever-evolving needs of the healthcare industry.

Furthermore, the collected data can be analyzed using advanced machine learning algorithms and predictive models, allowing for the identification of potential risk factors and the prediction of healing outcomes. This data-driven approach not only supports personalized treatment plans but also contributes to advancing research in wound care and improving overall healthcare practices. The hardware and software implementations of the proposed wound monitoring system are seamlessly integrated, leveraging cutting-edge technologies

and best practices in sensor technology, microcontroller programming, cloud computing, and data visualization. The careful selection of components, robust data transmission protocols, and scalable software architecture ensure that the system provides accurate, reliable, and comprehensive wound assessment capabilities. By addressing critical considerations such as data privacy and security, and prioritizing usability and accessibility, this system has the potential to transform wound care practices, empowering healthcare professionals and patients alike with actionable insights and data-driven decision-making tools.

Figure 3 shows a screenshot of the ThingsBoard dashboard, a web-based platform used for the visualization and analysis of data collected by the proposed wound monitoring system. ThingsBoard is an open-source IoT platform that offers robust data management, real-time visualization, and advanced analytics capabilities. In the dashboard displayed, various widgets and charts present the sensor data received from the wound monitoring system in an intuitive and user-friendly manner. These visual representations likely include line graphs, heat maps, or other graphical elements that depict the trends and fluctuations of key parameters such as temperature, humidity, strain, and pressure over time.

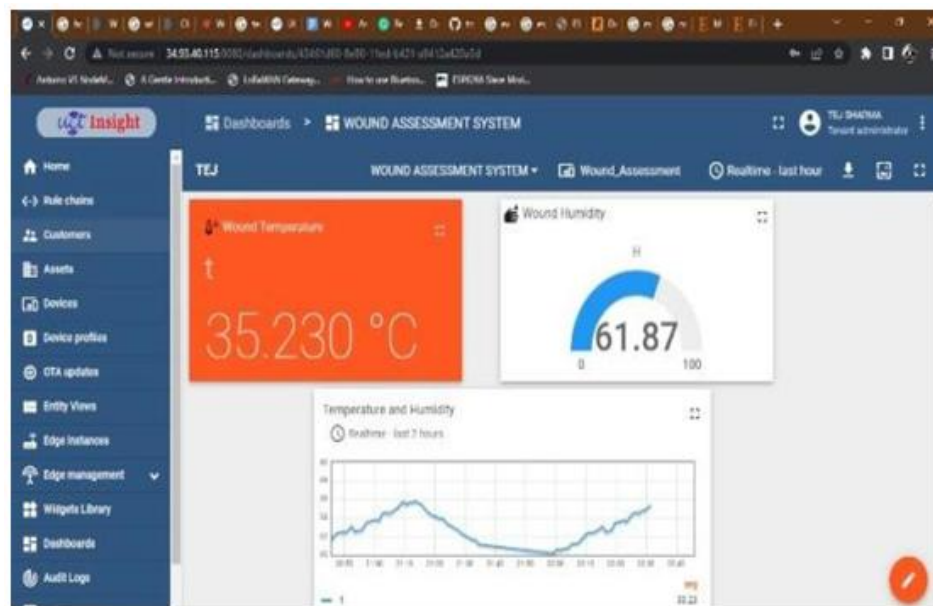
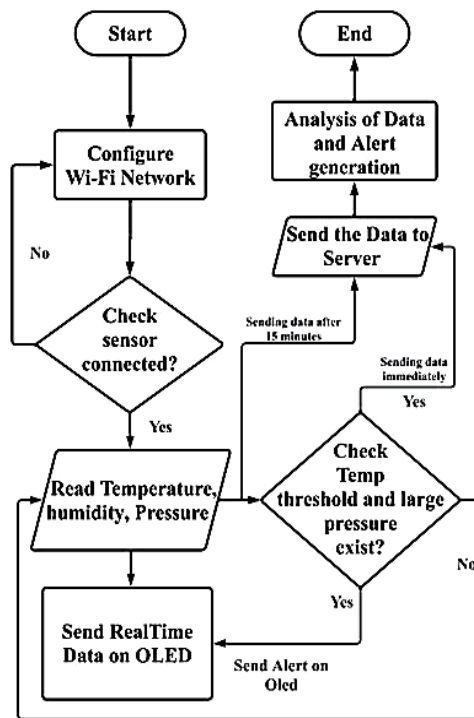

**Figure 3:** The image depicts the web-based ThingsBoard platform, which serves as the visualization and analytics interface for the data collected by the proposed wound monitoring system.

The ThingsBoard dashboard serves as a central hub where healthcare professionals can access and interpret the comprehensive data collected from the patient's wound. This visual interface allows for easy monitoring of the wound's condition, identification of potential issues or deviations from expected healing patterns, and informed decision-making regarding treatment plans and interventions. By leveraging the capabilities of the ThingsBoard platform, the proposed wound monitoring system enables seamless data integration, real-time visualization, and historical analysis, empowering healthcare providers with the necessary tools to deliver personalized and optimized wound care to their patients. The intuitive dashboard design ensures that the collected data is presented in a clear and

actionable manner, supporting the overall goals of improving patient outcomes and enhancing wound healing.

ThingsBoard offers a user-friendly interface with drag-and-drop widgets that can be customized to display the data from the proposed wound monitoring system. In the depicted dashboard, the data collected from the ESP32 microcontroller via a Wi-Fi connection to a mobile device is visualized through various graphs and charts. This dashboard allows for the real-time monitoring and analysis of the sensor data, such as temperature, humidity, strain, and pressure, related to the wounded area. It is important to note that while the dashboard shown in the figure has been tested with virtual data, the full capabilities of the system have not yet been validated using real wound-based data. The development and testing of the wound monitoring system, including the integration with the ThingsBoard platform, are still ongoing processes to ensure the accuracy and reliability of the data visualization and analysis functionalities.



**Figure 4:** Flowchart Depicting Temperature and Humidity Sensing through SHT20 Sensor and Sending Data to the Microcontroller and then to ThingsBoard App via Wi-Fi.

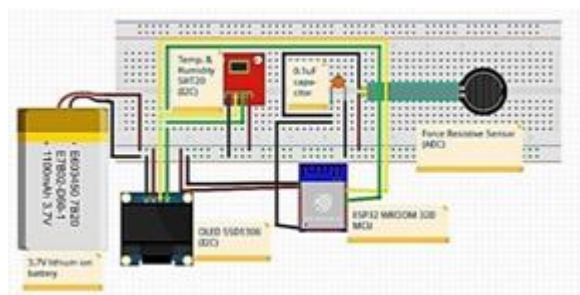

**Figure 5:** Circuit Diagram of wound Assessment System Using Wi-Fi and Esp32

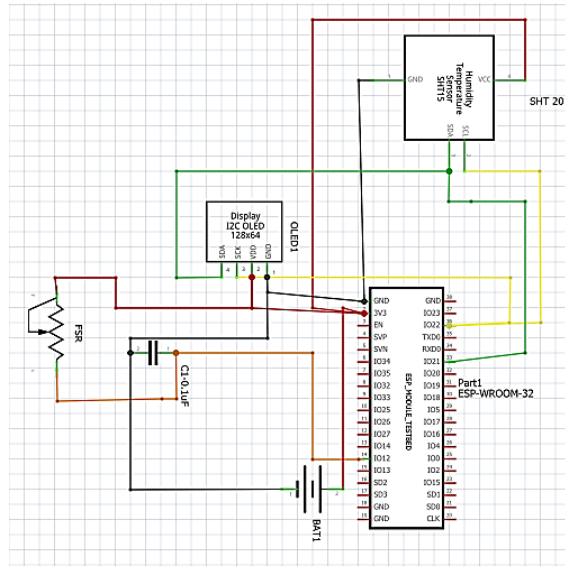

**Figure 6:** Schematic Diagram Depicting the Various Connections in the wound Assessment System

Figure 5 depicts the circuit design of the proposed system, and 6 illustrate its schematic diagram.

### VIII. RESULTS

Wound assessment and monitoring are critical components in delivering effective wound care and promoting faster healing. The goal of the proposed work and methodology is to present the design of a distributed wound assessment system that is portable, user-friendly, and addresses the limitations of existing wound assessment tools. The key objective is to develop a novel wound assessment system that builds upon the strengths of current solutions while introducing innovative features and functionalities. The proposed system aims to provide healthcare professionals with a reliable, comprehensive, and easy-to-use tool for evaluating and monitoring various types of wounds, including chronic and acute conditions.

One of the primary considerations in the design of the proposed system is the seamless integration of advanced technologies to enhance the wound assessment process. The system leverages the capabilities of microcontrollers, wireless connectivity, and sensor integration to create a distributed and portable solution. A comparative analysis has been conducted to evaluate the proposed module, which is based on the ESP32 microcontroller, against an Arduino-based wound assessment system. This comparison has revealed several advantages of the proposed approach:

**Form Factor and Weight:** The proposed module, built around the ESP32 microcontroller, has a significantly smaller form factor and weighs less than the Arduino-based system. This compact design enhances the portability and ease of use, allowing healthcare professionals to integrate the wound assessment system into their workflows more conveniently.

The proposed module incorporates current wireless technologies, such as Wi-Fi, to enable seamless data transmission and communication. This wireless capability eliminates the need for cumbersome wired connections, making the system more versatile and adaptable to various clinical settings. It is designed to integrate a comprehensive array of sensors to capture a wide range of wound-related parameters. This includes sensors for measuring temperature, humidity, strain, pressure, and other relevant physical characteristics of the wound. By collecting this multifaceted data, the system can provide a more holistic assessment of the wound's condition.

The collected sensor data is transmitted wirelessly to a cloud-based platform, such as ThingsBoard, for real-time visualization and analysis. Healthcare professionals can access the data through a user-friendly dashboard, allowing them to monitor wound progression, identify potential issues, and make informed decisions regarding treatment plans. To ensure data integrity and continuity, the proposed system incorporates a redundant data storage mechanism. The sensor data is stored locally on the microcontroller's EPROM (Erasable Programmable Read-Only Memory) as well as on the cloud-based platform. In the event of a network disruption, the locally stored data can be seamlessly synchronized with the cloud once the connection is re-established.

The modular design of the proposed system enables scalability and future expandability. As new sensor technologies or assessment parameters emerge, the system can be easily adapted to incorporate these advancements, ensuring it remains relevant and aligned with the evolving needs of wound care practices. The development of the proposed wound assessment system follows a structured and iterative approach. The initial phase involves a comprehensive review of existing wound assessment tools and techniques, identifying their strengths, limitations, and areas for improvement. This analysis informs the design and implementation of the proposed system, ensuring it addresses the key challenges faced by healthcare professionals in the wound assessment and monitoring process.

The hardware and software components of the proposed system are designed to work in tandem, providing a seamless and integrated solution. The hardware implementation focuses on the selection and integration of the appropriate sensors, microcontroller, and wireless communication modules. The software implementation, on the other hand, encompasses the development of firmware for the microcontroller, data transmission protocols, and the user interface for data visualization and analysis. To ensure the reliability and effectiveness of the proposed wound assessment system, a rigorous testing and validation process is undertaken. This includes laboratory-based evaluations, clinical trials, and user feedback assessments. The system is tested with both synthetic and real wound data to validate its accuracy, consistency, and ease of use.

Furthermore, the proposed system is designed with a strong emphasis on data privacy and security. Robust measures are implemented to protect patient information and ensure compliance with relevant regulations and standards. This includes data encryption, access control mechanisms, and secure data handling protocols. The successful implementation of the proposed wound assessment system has the potential to revolutionize wound care practices. By providing healthcare professionals with a comprehensive, objective, and user-friendly tool for wound assessment and monitoring, the system can lead to improved patient outcomes, faster healing, and more efficient utilization of healthcare resources. Additionally,

the data collected and analyzed by the proposed system can contribute to advancing wound care research and the development of predictive models. This data-driven approach can enable the identification of risk factors, the prediction of healing trajectories, and the optimization of treatment strategies, ultimately enhancing the overall quality of wound care delivery.

The proposed wound assessment system represents a significant advancement in the field of wound care. By leveraging the power of modern technologies, including microcontrollers, wireless connectivity, and sensor integration, the system aims to address the limitations of traditional wound assessment methods and provide healthcare professionals with a robust and user-friendly tool for monitoring and managing wounds. The emphasis on portability, data integrity, and scalability ensures that the proposed system can be seamlessly integrated into various clinical settings, improving patient outcomes and supporting the continuous advancement of wound care practices.

**Table 2:** Comparative Analysis of Microcontroller Specifications Between Arduino Uno-based and ESP32-based Wound Assessment Systems

Parameters	Arduino Uno	ESP32 (Proposed System)
Size(mm)	53.4mm x 68.6mm	28mm x 25.5mm
Weight (gm)	25gm	2.5gm
Connectivity	Doesn't have inbuilt wireless connectivity modules	It has integrated Bluetooth and Wi-Fi modules

## IX. CONCLUSION

The integration of wireless connectivity and continuous data storage addresses two critical challenges in wound assessment: accessibility and continuity. By leveraging modern technology, the proposed system empowers patients and healthcare professionals to monitor wounds remotely and continuously, without the need for frequent in-person visits or disruptions in data collection. Furthermore, the system's ability to visualize data in an intuitive and user-friendly manner addresses the issue of subjective interpretations often associated with traditional wound assessment methods. By presenting quantitative data in a graphical format, the system eliminates ambiguity and ensures that both patients and healthcare providers have access to objective and standardized information.

The potential benefits of this research extend beyond the realm of wound care. By enabling remote monitoring and continuous data collection, the proposed system can facilitate early intervention and proactive care, reducing the risk of complications and promoting faster healing. Additionally, the system's data storage and synchronization capabilities can support longitudinal studies and research efforts, providing valuable insights into wound healing patterns and the effectiveness of various treatment approaches. It is important to note that while the proposed system addresses the issue of timely wound assessment, it is not intended to replace the expertise and clinical judgment of healthcare professionals. Rather, it serves as a complementary tool, providing objective data and insights to support informed decision-making and personalized treatment plans.

Adequate training and support should be provided to ensure that patients and healthcare professionals are comfortable with using the system and interpreting the data visualizations effectively. As the system involves the collection and transmission of sensitive health data, robust data privacy and security measures must be implemented to protect patient confidentiality and comply with relevant regulations.

**Integration with Existing Healthcare Systems:** For seamless adoption, the proposed system should be designed to integrate with existing healthcare infrastructure and electronic medical record systems, facilitating seamless data sharing and collaboration among healthcare providers. The system should be designed with scalability in mind, allowing for future expansion and the incorporation of additional sensors or functionalities as the need arises. Additionally, the system should be adaptable to various wound types and patient populations, ensuring its widespread applicability. To promote widespread adoption, the system should be cost-effective and accessible to a diverse range of healthcare settings and patient populations, regardless of their socioeconomic status or geographical location.

By addressing these considerations and fostering collaboration among researchers, healthcare professionals, and technology experts, this research has the potential to revolutionize wound care practices and improve patient outcomes significantly. This research chapter presents a novel and innovative approach to addressing the critical issue of timely wound assessment. By leveraging wireless connectivity, continuous data storage, and intuitive data visualization, the proposed system empowers patients and healthcare professionals to monitor wounds remotely and continuously, facilitating early intervention and promoting faster healing. While this system represents a significant step forward in wound care, ongoing research, development, and collaboration are essential to refine and optimize its implementation, ensuring that it delivers the maximum possible benefits to patients and healthcare systems worldwide.

This chapter presents a design of a system for monitoring wound healing concerning time which can be implemented and tested on real wounds. The testing on wound has been done virtually and its results by virtual testing have been presented in the chapter. It not only assists the doctors in assessing the wound more effectively but also helps them to take timely actions to treat the wound. This proposed system measures several parameters, including temperature, humidity, and pressure associated with the impairment, to monitor the healing and to guide doctors toward the best practice. It helps to avoid the severity of the wound at the earliest time possible. The system is wholly capable of directing the status of the damage, i.e., if the injury is progressing in the direction of recovery or not. This module is easily compatible with the bandage as it is small and enclosed with wearable sensors. The real-time sensor data was stored in a database and projected on a graph on the ThingsBoard Dashboard for better analysis of the progress. When the parameter values do not go as per the desired nature, a notification is sent to the patient's consulting doctors or their respective caretaker to avoid any fatal condition. This system can be very effective in assessing the wounds of patients with diabetes, anemia, or some vascular diseases that restrict blood flow to the infected area, as they require regular inspections.

This chapter presents the design of a comprehensive wound monitoring system that can be implemented and tested on real-world wounds. While the initial testing has been done using virtual data, the results have been presented in the chapter. This proposed system aims to

not only assist healthcare professionals in effectively assessing the wound but also enable timely interventions to promote healing. The system measures a range of parameters, including temperature, humidity, and pressure, associated with the wounded area. By continuously monitoring these factors, the system can provide valuable insights into the wound's healing progress and guide healthcare professionals towards the most appropriate treatment strategies.

One of the key benefits of this proposed system is its ability to detect potential complications or deviations from the expected healing trajectory at the earliest possible stage. The system is capable of continuously directing the status of the wound, indicating whether it is progressing towards recovery or not. This early warning capability can help healthcare providers take timely action to prevent the wound from deteriorating further. The compact and wearable design of the system allows it to be easily integrated with wound dressings or bandages, making it convenient for patient use. The real-time sensor data is stored in a database and visualized on the ThingsBoard dashboard, providing healthcare professionals with a comprehensive and user-friendly interface to analyze the wound's progression. An important feature of the proposed system is its ability to send notifications to the patient's consulting healthcare providers or caregivers when the monitored parameters deviate from the desired range. This proactive alert system can be particularly beneficial for patients with underlying conditions, such as diabetes, anemia, or vascular diseases, which can adversely affect wound healing and require regular monitoring. The versatility of this wound monitoring system makes it a valuable tool for a wide range of healthcare settings. It can be especially effective in assessing and managing wounds in patients with chronic conditions that impair blood flow and tissue perfusion, as these patients often require frequent inspections and intervention to prevent complications.

By integrating cutting-edge sensor technology, wireless connectivity, and data visualization capabilities, this proposed system aims to revolutionize the way wound assessment and monitoring are conducted. The objective and continuous data collection, coupled with the ability to provide timely notifications and guidance, can empower healthcare professionals to deliver more personalized and effective wound care, ultimately leading to improved patient outcomes and accelerated healing.

## **X. FUTURE SCOPE**

In envisioning the future trajectory and potential enhancements of this system, it becomes imperative to delve into its practical implementation, wherein its efficiency and various parameters can be meticulously recorded and compared against those of conventional state-of-the-art technologies. Moving forward, the practical implementation of this system entails the deployment of real-world scenarios where its functionalities and performance metrics can be rigorously assessed. Through this process, it will be possible to gauge its efficiency, accuracy, speed, and other pertinent parameters in comparison to existing technologies widely regarded as the benchmark in their respective domains. By conducting empirical studies and experiments, researchers and practitioners can gain valuable insights into the system's strengths, weaknesses, and areas for improvement. This empirical data will serve as a cornerstone for refining the system and optimizing its performance to align with the evolving demands and challenges of the technological landscape.



Furthermore, the comparative analysis between this system and conventional technologies will provide invaluable benchmarks and metrics for evaluating its efficacy and potential impact. This comparative study will not only highlight the advantages and innovations offered by this system but also shed light on areas where further enhancements and optimizations are warranted. Moreover, the future scope of this system extends beyond mere performance evaluation to encompass broader applications and domains. As technology continues to evolve and diversify, there arises a need to explore novel use cases and scenarios where this system can be deployed to drive innovation and address pressing challenges. For instance, in the realm of artificial intelligence and machine learning, this system could be leveraged to enhance predictive analytics, anomaly detection, and decision-making processes across various industries such as healthcare, finance, manufacturing, and transportation. Its adaptability and scalability make it well-suited for tackling complex problems and unlocking new opportunities for efficiency and optimization.

Additionally, the integration of emerging technologies such as blockchain, Internet of Things (IoT), and edge computing presents new frontiers for exploration and application. By harnessing the synergies between these technologies, this system can pave the way for transformative solutions in areas like supply chain management, cybersecurity, smart cities, and environmental monitoring. In essence, the future scope and work of this system encompass a multifaceted approach that spans practical implementation, empirical evaluation, comparative analysis, and exploration of new applications and domains. Through continuous refinement, innovation, and collaboration, it holds the promise of revolutionizing existing paradigms and shaping the future of technology in profound ways.

## **XI. REFERENCES**

- [1] Mydhili, S. K., Dr Mydhili SK, Fathima Naseera M, and Ranjith Kumar R. "An IoT based Foot Healthcare System for Diabetic Patients and a Futuristic Approach for transforming Sensor Data into real-time Medical Advice." *Proceedings of the Advancement in Electronics & Communication Engineering* (2022).
- [2] Khalil, Ashraf, Mohammed Elmogy, Mohammed Ghazal, Connor Burns, and Ayman El-Baz. "Chronic wound healing assessment system based on different features modalities and non-negative matrix factorization (nmf) feature reduction." *IEEE Access* 7 (2019): 80110-80121.
- [3] Ohura, Norihiko, Ryota Mitsuno, Masanobu Sakisaka, Yuta Terabe, Yuki Morishige, Atsushi Uchiyama, Takumi Okoshi, Iizaka Shinji, and Akihiko Takushima. "Convolutional neural networks for wound detection: the role of artificial intelligence in wound care." *Journal of Wound Care* 28, no. Sup10 (2019): S13-S24.
- [4] Xu, Gang, Yanli Lu, Chen Cheng, Xin Li, Jie Xu, Zhaoyang Liu, Jinglong Liu et al. "Battery-free and wireless smart wound dressing for wound infection monitoring and electrically controlled on- demand drug delivery." *Advanced Functional Materials* 31, no. 26 (2021): 2100852.
- [5] Lou, Dong, Qian Pang, Xiachuan Pei, Shurong Dong, Shijian Li, Wei-qiang Tan, and Lie Ma. "Flexible wound healing system for pro-regeneration, temperature monitoring and infection early warning." *Biosensors and Bioelectronics* 162 (2020): 112275.
- [6] Zhang, Yuheng, Bin Lin, Rong Huang, Zhixiao Lin, Yongqian Li, Jinqing Li, and Xueyong Li. "Flexible integrated sensing platform for monitoring wound temperature and predicting infection." *Microbial Biotechnology* 14, no. 4 (2021): 1566-1579.
- [7] Mukherjee, Rashmi, Suman Tewary, and Aurobinda Routray. "Diagnostic and prognostic utility of non-invasive multimodal imaging in chronic wound monitoring: a systematic review." *Journal of medical systems* 41 (2017): 1-17.
- [8] Wang, Lei, Peder C. Pedersen, Diane M. Strong, Bengisu Tulu, Emmanuel Agu, and Ronald Ignatz. "Smartphone-based wound assessment system for patients with diabetes." *IEEE Transactions on Biomedical Engineering* 62, no. 2 (2014): 477-488.

- [9] Sattar, Hina, Imran Sarwar Bajwa, Riaz Ul Amin, Nadeem Sarwar, Noreen Jamil, MG Abbas Malik, Aqsa Mahmood, and Umar Shafi. "An IoT-based intelligent wound monitoring system." *IEEE Access* 7 (2019): 144500-144515.
- [10] Dubey, Kajal, and Tushar Gupta. "Adaptive traffic control system: The smart and imperative traffic control system for India." In *2020 International Conference on Intelligent Engineering and Management (ICIEM)*, pp. 91-96. IEEE, 2020.
- [11] Ms Indujha. "Automated Wound Assessment System for Foot Ulcer Patients with Diabetes." *I- Manager's Journal of Pattern Recognition* 8, no. 1 (2021).