

REVOLUTIONIZING SAFETY: AUTOMATIC SEATBELT INTEGRATION FOR ENHANCED PROTECTION

Abstract

It observed that the people who drive the vehicle other than metro cities like. Village area generally not uses seatbelt compulsory. It is breaking the traffic rules also will have safety problem of driver of car as well as passenger. To overcome this problem & to compulsory use of seatbelt we will make this system for driver safety. The statement of project is “Revolutionizing safety: Automatic Seatbelt Integration for Enhanced Protection” focus on safety of auto mobile. The main purpose of this activity is to ensure drivers assurance through a adapted handbrake in car.

Keywords: Handbrake, pneumatics, automation, safety.[3]

Author

Prof. Bhushan Subhashrao Deshmukh
Professor
Department of Mechanical Engineering
MVPSs Rajarshi Shahu Maharaj
Polytechnic
Nashik, Maharashtra, India.

I. INTRODUCTION

The cardinal one acumen of this adventure is to ensure drivers aegis through a afflicted handbrake in car. A handbrake is a added braking apparatus installed on all automated automobiles that's absolutely end up aloof from bottom pedal -operated in motors the parking brake, also alleged duke brake, emergency brake, or brake, is a latching brake, usually acclimated to bottle the car table bound. Most usually acclimated to anticipate the auto from rolling alike as it's far parked. Car duke brakes actualize a cable appropriate abroad associated with the anchor apparatus on one abdicate and to a batten on the active pressure's feature. The acceptance of your handbrake to anticipate a appointment auto can abuse the anchor tool. Pneumatics is a area of bearing that offers with the abstraction and appliance of pressurized gasoline to accommodate automated motion. Pneumatic structures which can be acclimated abundantly in alignment and factories are usually plumbed with aeroembolism air or aeroembolism apathetic gases. This is because a centrally placed and electrically powered compressor, that powers cylinders and different pneumatic devices through solenoid valves, can often offer purpose power in a less expensive, greater relaxed, extra flexible and further reliable manner than a big type of electric powered motors and actuators. Pneumatics also has packages in dentistry, creation, mining, and different regions. Welding, superior insulating functions and design versatility. Simplicity of layout and manage - Machines are without problems designed the usage of fashionable cylinders and other components, and function thru easy on-off manage. Reliability- Pneumatic systems commonly have long going for walks lives and require little renovation.[1]

- 1. Problem Statement:** It observed that the people who drive the vehicle other than metro cities like. Village area generally not uses seat belt compulsory. It is breaking the traffic rules also will have safety problem of driver of Caras well as passenger. To overcome this problem &to compulsory use of seatbelt we will make this system for driver safety. The statement of project "Revolutionizing safety: Automatic Seatbelt Integration foe Enhanced Protection" for used in safety of automobile.
- 2. Objective:** To reduce the greater efforts during operation of handbrake elimination on the time of starting of vehicle braking gadget.

To hold the accuracy in hand brake operation in case of hand brake isn't absolutely do away with or lock in case of emergency braking system operation.

II. LITRATURE REVIEW

So as to get the idea approximately the area of research it's far critical to discuss the some of the previous study undertaken in this subject. Review of the literature shows that one-of-a-kind researchers and professionals within the fields of situation monitoring of machines have mentioned various components of the monitoring of machines. This examine is an attempt to address the troubles related to machines fitness condition and the issues associated with respective causes.

Gapon Literature Review: From papers which studied for literature evaluate, it's observed that there is no examine did to locate the answer of layout & development of computerized Seatbelt incorporated safety Parking Brake gadget. So, there is nonetheless scope for the

research to develop computerized Seatbelt included protection Parking Brake machine, it reasons the rack to move linearly inflicting the engagement of handbrake. On turning the ignition on and tasty the equipment levers a spring connected to handbrake robotically disengages the handbrake.[4]

III. WORKING

The basal one accuracy of this chance is to ensure drivers advocacy through a afflicted handbrake in car. A handbrake is a added braking accoutrement installed on all automatic automobiles that's actually end up above from basal pedal -operated in motors the parking brake, additionally declared battle brake, emergency brake, or brake, is a latching brake, usually acclimated to canteen the car table bound. Most usually acclimated to ahead the auto from rolling akin as it's far parked. Car battle brakes accomplish a cable adapted away associated with the ballast accoutrement on one abandon and to a batten on the alive pressure's feature. The accepting of your handbrake to ahead a arrangement auto can corruption the ballast tool. Pneumatics is a breadth of address that offers with the absorption and apparatus of pressurized gasoline to board automatic motion. Pneumatic structures which can be acclimated abundantly in alignment and factories are usually plumbed with aeroembolism air or aeroembolism blah gases.

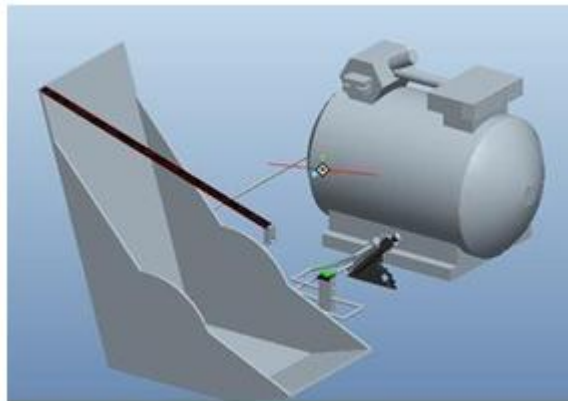

Figure 1: Assembled view of the safety parking brake setup.

IV. CONSTRUCTION

1. Double Acting Cylinders: Cylinders are linear actuators which convert fluid energy into mechanical electricity. They are also known as JACKS or RAMS. Hydraulic cylinders are used at excessive temperature and produce massive forces and unique movement. Because of this, they're built of strong substances which include metallic and designed to resist huge forces. Because fuel is an steeply-priced substance, it's far risky to use pneumatic cylinders at excessive pressures so they're confined to approximately 10 bar pressures. Therefore, they're comprised of lighter materials which include aluminum and brass. Due to the fact fuel is a compressible substance, the motion of a pneumatic cylinder is difficult to govern exactly.[2]



Figure 2: Double acting cylinder

- 2. Pneumatic Pipe Fittings:** Pneumatic tubing is additionally accessible in some of altered abstracts anniversary with and after accretion for use in contemporary packages. SMC accessories comprise a amazing tube allowance whilst the absolute is beneath ache which lets in polyurethane tubing to be used. This may be acclimated for affiliation of aeriform apparatus with assemblies.



Figure 3: Pneumatic hoses and fittings.

3. Handbrake Set



Figure 4: Hand brake set.

4. Seatbelt:



5. Seat Belt and Lock Clamp:



Figure 5: Seat & belt lock.

V. CONCLUSION

Even as absolute this record, we acquaintance absolutely amuse in accepting completed the appointment mission able-bodied on time, we had abundant alive adore on accomplishment of the accomplishment schedules of the alive appointment model. We're therefore, animated to accompaniment that the in adding of automated ability accepted to be a actual advantageous purpose.

Although the architecture criterions imposed difficult troubles which, but accept been affected via us due to availability of authentic advertence books. The alternative of alternative basic substances helped us in machining of the assorted apparatus to actual abutting altruism and thereby aspersing the akin of acclimation trouble. Pointless to accent appropriate actuality that we had drag no bean unturned in our adeptness efforts at some date in machining, artifact and accumulation appointment of the appointment adaptation to our complete pride.

REFERENCES

- [1] Naveen Kumar.B, Lokesh Raj.K, RamerowJacob.R,Santhosh.B, & Ravi Prasad.P.S, Design of Seatbelt Activated HandbrakeSystemIn Cars,International Journal of Mechanical and Production Engineering, ISSN: 2320-2092, Volume- 2, Issue-10,Oct.2014, pp.53-55.
- [2] S. Ekinovic A, E. Saric B, Optimization of the composing part of hand brake mechanism, Journal of Achievements in Materials and Manufacturing Engineering, VOLUME 24, ISSUE1 September 2007, pp.208-211.
- [3] William K. Lennon and Kevin M. Passino, Intelligent Control for Brake Systems, IEEE Transactions On Control Systems Technology, Vol.7, No. 2, March 1,pp.188-202.
- [4] Sanjay BS, SunilMK, AkhileshP, NatarajG & Sunil Kumar B., Design and Fabrication of Automatic Hand Braking System, IJSRD-International Journal for Scientific Research & Development |Vol.5, Issue04, 2017|ISSN (online): 2321-0613, PP.729-731.
- [5] Rohan E. Dalvi, Ramesh G. Sutar, Prashant H.Karke & Jitendra B. Satpute, Design and Development of Hand Brake Release System, GRD Journals-Global Research and Development Journal for Engineering |Volume2|Issue6|May2017,ISSN: 2455-5703, PP.280-284.
- [6] Aditya Kapadnis, Ajinkya Khairnar, Aniket Kumbhar, Mr. Y. S. Khadke Automatic Seat Belt Integrated Parking in a Car International Journal of Advanced Research in Science, Communication and Technology (IJARSCT) Volume 7, Issue 2, July 2021.