

LOOP MEDIATED ISOTHERMAL AMPLIFICATION (LAMP): A PROMISING ALTERNATIVE TO PCR IN MOLECULAR DIAGNOSTICS

Abstract

A Loop Mediated Isothermal Amplification (LAMP) is a simple, fast, explicit and cost-effective nucleic acid amplification method comparative to PCR (Polymerase Chain Reaction). It is nucleic acid sequence based, self-sustained sequence replication and strand displacement amplification. This technique uses *Bst* DNA polymerase and specifically sequenced (designed) four to six primer pairs which recognize total six to eight different target sequences on template strand. As a result of amplification, a large amount of DNA is synthesized, yielding a large pyrophosphate ion as by-product. It is a recognized nucleic acid amplification method offering rapid, accurate and cost-effective diagnosis of infectious diseases.

Keywords: LAMP, Amplification, PCR, *Bst* DNA polymerase

Authors

Dr. Rajesh J. Panchal

Assistant Professor
Department of Genetics and Plant Breeding
College of Agriculture
Madhav University
Rajasthan, India.

Dr. Rukhsar C. Bamji

Ph.D. Scholar
Department of Genetics and Plant Breeding
N. M. College of Agriculture
Navsari Agricultural University
Gujarat, India.

Dr. Kalpesh G. Raval

Ph.D. Scholar
Department of Genetics and Plant Breeding
N. M. College of Agriculture
Navsari Agricultural University
Gujarat, India.

I. INTRODUCTION

In the branch of molecular biology, there are two main technologies for amplification of nucleic acid *i.e.*, Isothermal amplification and Non-isothermal amplification. In isothermal amplification, nucleic acid amplification is carried out at a single temperature while in later one amplification is carried out varied range of temperature. Non-isothermal amplification includes technique of Polymerase Chain Reaction (PCR) developed by Kary Mullis (1983). Isothermal amplification includes several techniques *viz.*, loop mediated isothermal amplification (LAMP), helicase dependent amplification (HDA), hybridization chain reaction (HCR), isothermal and chimeric primer initiated amplification of nucleic acid (ICAN), nucleic acid sequence based amplification (NASBA), rolling circle amplification (RCA), Recombinase Polymerase Amplification (RPA), transcription-mediated amplification (TMA), signal mediated amplification of RNA technology (SMART), strand displacement amplification (SDA), isothermal multiple displacement amplification (IMDA), single-primer isothermal amplification (SPIA), exponential nucleic acid amplification reaction (EXPAR) and Q-beta replicase (Tomlinson and Boonham, 2008).

II. HISTORY OF LAMP IN FIELD OF AGRICULTURE

- 1998 - Eiken Chemical Co. Ltd. designed LAMP
- 2000 - First report of LAMP was given by Notomi *et al.*
- 2003 - First time LAMP was used for *E. coli* detection by Maruyama *et al.*
- 2004 - LAMP was used in detection of the thermo-dependent fungus *Paracoccidioides brasiliensis* by Endo *et al.*
- 2004 - First time LAMP was used for GM soybean screening by Fukuta *et al.*
- 2005 - First time LAMP was used in plant pathology for virus detection in potato by Nei
- 2005 - First time species discrimination (*C. longa* and *C. aromatica*) was carried with LAMP by Sasaki and Nagumo
- 2008 - LAMP was used for food contamination detection by Wang *et al.*
- 2008 - LAMP was used for distinguishing organism by SNP polymorphism by Ithraa *et al.*
- 2013 - LAMP was used for on-site GMO detection by Zhang *et al.*
- 2021 - First time LAMP was used for genotyping in rice by Prasannakumar *et al.*

III. REQUIREMENTS OF LAMP

To carry out successful amplification of LAMP, it requires following basic components (Notomi *et al.*, 2000).

1. **Primers:** A LAMP technique utilizes specifically sequenced (designed) four to six primer pairs targeting or recognizing six to eight different region in genome *viz.*, internal primer (FIP and BIP) (long 45–49 bp), external primer (F₃ and B₃) (shorter 21–24 bp) and loop primer (FLP and BLP).

The main primer used in LAMP are as follows:

- **Forward Inner Primer (FIP):** The FIP consists of a F₂ region at the 3' end and a F_{1c} region at the 5' end. The F₂ region is complementary to the F_{2c} region of the template sequence. The F_{1c} region is identical to the F_{1c} region of the template sequence; requires throughout amplification.
- **Backward Inner Primer (BIP):** The BIP consists of a B₂ region at the 3' end and a B_{1c} region at the 5' end. The B₂ region is complementary to the B_{2c} region of the template sequence. The B_{1c} region is identical to the B_{1c} region of the template sequence; requires throughout amplification.
- **Forward Outer Primer (FOP):** The FOP (also called as F₃ Primer) consists of a F₃ region which is complementary to the F_{3c} region of the template sequence. This primer is shorter in length and lower in concentration than FIP; requires at initial stage of amplification.
- **Backward Outer Primer (BOP):** The BOP (also called as B₃ Primer) consists of a B₃ region which is complementary to the B_{3c} region of the template sequence. This primer is shorter in length and lower in concentration than BIP; requires at initial stage of amplification.

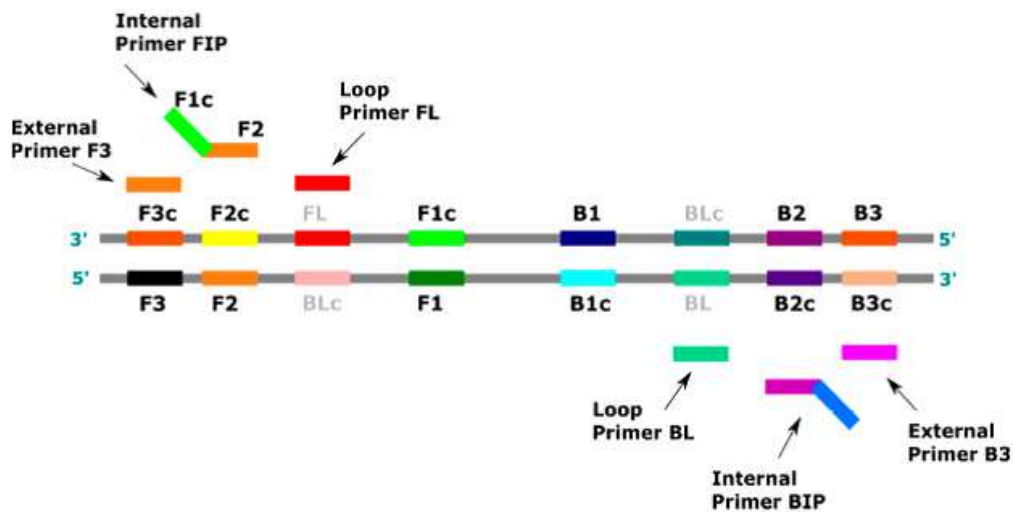

Figure 1: Different primers used in the LAMP reaction (Source: Soroka *et al.*, 2021)

In LAMP primers, a size and sequence of primers are designed such a way that their melting temperature (T_m) fall within certain regime (Notomi *et al.*, 2000). A melting temperature (T_m) of B₂ of BIP and F₂ of FIP should be fell in a range of 60 to 65 °C, as in this range the activity of LAMP enzyme *i.e.*, *Bst* DNA polymerase is optimum. A melting temperature (T_m) of B_{1c} of BIP and F_{1c} of FIP were set little higher than those of B₂ and F₂, in order to that a loop structure will be formed immediately after release of single stranded DNA. Same way, melting temperature (T_m) of B₃ and F₃ should be lower than those of B₂ and F₂, in order to ensure that synthesis from inner primer occurs earlier than outer primer.

2. ***Bst* DNA Polymerase:** This LAMP enzyme (derived from the large fragment of *Bacillus stearothermophilus* DNA Polymerase I) has heat resistant property and a strand displacement type of DNA polymerase (5' to 3' polymerase) activity (lack of 5' to 3'

exonuclease, as it is removed by genetic engineering), which amplifies a new strand of DNA while dissociating the hydrogen bond of the double stranded template DNA by itself. Since the strand displacement DNA polymerase does not require dissociation of double stranded DNA by its characteristics, DNA can be synthesized at a constant temperature and the synthesis is not inhibited by the secondary structure of DNA. It is suitable for synthesis of DNA strands having high GC content and having high purity/high quality control. An optimum suitable temperature for polymerase activity is 60 to 65 °C, while inactivating temperature is 80 °C. It also fulfills the wide range of gap between mesophilic and thermophilic polymerase enzymes.

The Bst DNA Polymerase (larger fragment of *Bacillus stearotherophilus* DNA Polymerase I, Figure 2) has optimum temperature of 60 to 65 °C which is higher than Klenow fragment and DNA Polymerase whereas lower than another enzyme having strand displacement activity i.e., Vent® DNA Polymerase

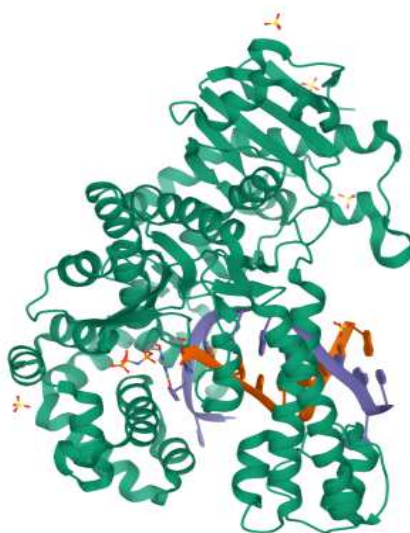

Figure 2: *Bst* DNA Polymerase

- 3. Buffer Solution:** It is a solution based on water solvent containing a weak acid and conjugating base of weak acid or vice a versa *i.e.*, weak base and conjugating acid of weak base. It helps in resisting in pH change during chemical reaction during amplification. The buffer used in LAMP reaction is 10X isothermal amplification buffer having five different salts and final pH of 8.8 at a temperature of 25 °C. A 1X buffer is made up of 20 mM Tris-HCl, 10 mM (NH₄)₂SO₄, 50 mM KCl, 2 mM MgSO₄ and 0.1 % Tween-20 or 0.1 Triton X-100. Among them, HCl and KCl work for pH maintenance, Mg²⁺ is enzyme co-factor whereas (NH₄)₂SO₄ increases amplification rates and thus giving higher amount of DNA yield. A Triton X-100 stabilize the enzyme and prevent enzyme and DNA to stick on tube well. In addition to these, Glycine betaine (1.0 M) is also added to enhance the amplification by dissolving secondary structure that blocks polymerase activity.
- 4. dNTPs:** These are the most important building blocks of nucleic acid amplification whether it is isothermal or non-isothermal. They are added into amplifying nucleic acid

chain during replication or amplification by the activity of polymerase enzyme. They are of mainly four types *viz.*, dATP, dTTP, dGTP and dCTP. Each of them is added in equal concentration.

5. Template DNA: Template DNA is the strand of DNA that is used for amplification.

IV. SOFTWARE USED FOR LAMP PRIMER DESIGNING

The primers used in LAMP assay are designed by using online software such as PrimerExplorer (V4 and V5), Premier Biosoft, LAMP Designer Optigene (Soroka *et al.*, 2021) and GLAPD (Jia *et al.*, 2019).

In LAMP protocol, primers are designed in such a way that distance between end of F₂ and end of B₂ (the region amplified by LAMP method) is between 120 to 160 base pairs. Besides this, distance between 5' end of F₂ to 5' end of F₁ (the portion that forms loop in LAMP) is between 40 to 60 base pairs.

V. HOW TO SET UP LAMP REACTION?

A reaction of LAMP assay is generally set up in 25 µl volume which contains following components (Notomi *et al.*, 2000) to carry out LAMP assay successfully in any molecular biological research.

- 1X LAMP buffer
- 8 U *Bst* DNA Polymerase
- 0.8 µM each inner primer (FIP and BIP)
- 0.2 µM each outer primer (F₃ and B₃)
- 400 µM each dNTP
- DNA

The above-mentioned components may vary or optimized based on research objectives and materials to be analyzed.

As this is an isothermal amplification methodology, to perform LAMP assay successfully there is no requirement of any thermal cycle machine as it requires in case of PCR. It is a simplest technique for amplification which involves mixing of all reagents except polymerase enzyme in appropriate concentration in a tube or vial. Once all the reagents are added in tube or vial, the sample is given a heat sock of 95 °C for 5 min as to denature dSDNA into ssDNA which is necessary for the new primer to bind and amplify it with the help of *Bst* DNA Polymerase. After a heat sock, the tube is immediately transferred on ice box to cool down the sample followed by adding of *Bst* DNA Polymerase. Again, after adding of an enzyme, a tube is transferred in water bath or heating block at temperature of 60 to 65 °C for 30 to 60 min. An enzyme will start to amplify the product and give a result that can be analyzed visually or by using fluorescent dye or available techniques. Based on obtained result, interpretation will be given for sample on test whether the sample is positive or negative for a gene of interest or any other microbes or contaminants.

VI. HOW TO DETECT LAMP ASSAYS?

Many possibilities have been developed to detect LAMP reactions *viz.*, Colorimetric detection using fluorescent dyes [e.g., SYBR Green, Calcein, EvaGreen, Malachite green, Hydroxy naphthol blue, Goldview, GelRed, SYTO fluorescent dye, Leuco crystal violet (LCV) and Berberine], Turbidity, UV light irradiation, Agarose gel electrophoresis, Real time fluorescence, Smartphone, Lateral flow assay (LFA) and AC susceptometry.

- 1. Colorimetric Detection Using Fluorescent Dyes:** This is an assay which is developed based on on-field or naked eye observation (Zhang *et al.*, 2014; Safavieh *et al.*, 2016) with end point colorimetric visual which is one of the most popular LAMP assays (Sayad *et al.*, 2018). It is simple method as it involves simple mean of heating of sample in question in water bath, thermos, pressure cooker or portable and/or portable battery-operated equipment for isothermal amplification followed by naked eye or on-field observation. For the interpretation and quantitative analysis of results, 'trained eyes' in needed. This problem can be overcome by digital image analysis employed in microfluid chips with nanoliter volume for end-point colour quantification (Rodriguez-Manzano *et al.*, 2016). The dye used for LAMP detection are SYBR Green, Calcein, EvaGreen, Malachite green, Hydroxy naphthol blue, Goldview, GelRed, SYTO fluorescent dye, Leuco crystal violet (LCV) and Berberine.
- 2. Turbidity:** In the LAMP assay, during the synthesis of DNA strand *i.e.*, amplification cycle, pyrophosphate is produced as a by-product and this yields white colored magnesium pyrophosphate as a precipitation in the reaction mixture. So, increase in DNA content due to amplification would increase in turbidity and *vice-a-versa*. This principle of turbidity is used for the detection and interpretation of LAMP results. Apart from these, by using real time measurement of turbidity, real time assessment of LAMP reaction can be achieved as amount of precipitate produced during synthesis (amplification) correlate with amount of DNA produced (Mori *et al.*, 2004). This result can be observed by bare eyes.
- 3. UV Light Irradiation:** When fluorescent dyes are used in LAMP assays, they transmit or emit a light of specific length when binds to dsDNA except calcein. This is viewed under UV irradiation and also be seen with naked eye on colour change. For the on-time quantitative measurement of the product, it can also be combined with real-time analysis.
- 4. Agarose Gel Electrophoresis:** A gel electrophoresis is oldest traditional approach for the LAMP detection. In this approach, the synthesized product of LAMP reaction is separated with the help of electric current and it can be visualized in form of bands of various size or length. Although, this is time consuming approach as it takes more time and increase risk of cross contamination between the large amounts of amplified products synthesized during amplification.
- 5. Real time Fluorescence:** Real time fluorescence is preferable due to its excellent sensitivity, specificity, and ease of use as it enables for a concurrent quantitative evaluation of the product. In general, fluorescence dye intensity could be used to visualize and quantify amplification. It works at constant temperature, usually between 60 °C and 70°C. Primers are fluorescently labelled and placed in amplifiable double stranded DNA

(dsDNA). False positive outcomes are possible to detect due to primer dimer formation (Guo *et al.*, 2018). It is equipped with target-specific fluorescently tagged strand displaceable probes to detect the samples which gives fluorescent colour at real time by binding with the target dsDNA and emitting fluorescence colour. The fluorescence sign intensifies as the amount or quantity of DNA in the sample increases, thus giving intense fluorescence signal.

- 6. Smartphone:** For interpreting sample assay findings, LAMP based assays have also begun to link with portable companion gear such as smartphones (Da Silva *et al.*, 2020). RT-LAMP uses a closed tube, multiplexable, target specific format for detection of samples. It makes use of a newly developed detection approach that incorporates the quenching of unincorporated amplification signal reporters (QUASR). QUASR is also fully compatible with complex sample matrices and helps to the carry out tests on a modular, wireless smartphone-operated platform. A low-powered isothermal heating module and a multicolor LED excitation module are controlled through Bluetooth by a proprietary smartphone application. The app also uses the phone camera to capture images, which are then processed by a revolutionary colour and luminance-based detection algorithm capable of recognizing multiplexed QUASR test signals with more accuracy than conventional image intensity analysis (Priye *et al.*, 2017).
- 7. Lateral Flow Assay (LFA):** Furthermore, LFA is a popular method since it is simple to use, useful for in-field applications, lightweight, portable, and inexpensive. Because of its great sensitivity, easiness, user-friendliness, and ease of use and easy interpretation of results, the LFA is a superior nucleic acid analytical instrument. A buffer loading pad, a conjugate pad, a test line, a control line, and an absorbent pad are all part of the LFA platform. Streptavidin-coated gold nanoparticles (AuNPs) were collected in the conjugate pad, and anti-digoxigenin and biotin were added to the test and control lines, respectively. In this, the conjugate pad was loaded with digoxigenin and biotin-labeled RT-LAMP products, and the biotin-labeled RT-LAMP products form a complex with AuNPs via streptavidin-biotin interactions. Then the buffer loading pad is loaded with diluent buffer, and the capillary flow delivers AuNPs from the conjugate pad to the test and control lines. The interaction of digoxigenin and anti-digoxigenin immobilizes the AuNP/RT-LAMP complexes at the test line, whereas biotin catches the AuNPs that did not form complexes. Violet bands at the test and control lines represent complexed and non-complexed AuNPs, respectively. The colorimetric indication can be easily seen with the bare eye (Lee *et al.*, 2016).
- 8. AC Susceptometry:** AC susceptometry, an extremely analytical sensitivity device capable of recognizing 1 attomolar (aM: 10⁻¹⁸ moles per litre) synthesized oligonucleotides of researched pathogens within 27 minutes, is alternative method for determining a positive LAMP reaction (Soroka *et al.*, 2021). Streptavidin magnetic nanoparticles (streptavidin MNPs) are mixed with LAMP reagents, containing the analyte and biotinylated primers, in the system. A portable AC susceptometer is then used to measure the LAMP results, and the changes in hydrodynamic volume are detected as quantifiable shifts in the Brownian relaxation frequency (Da Silva *et al.*, 2020).

VII. APPLICATIONS

The LAMP is most widely used in detection and diagnosis of contagious diseases (humans & domesticated animals), identification of micro-organism, detection of pathogens (*viz.*, virus, bacteria, fungus and other parasite) causing disease in humans and animals, detection of plant and animal pathogens, differentiation of crops species and strains of microbes, detection of GMO, determination of adulteration and sex determination in humans and animals.

VIII. ADVANTAGES

The major advantages of the LAMP assays include (i) isothermal temperature (ii) high amplification efficiency due to tremendous amount of amplification products, (iii) highly specific reaction, (iv) fast and cost effective (v) any DNA sample can be used & more tolerant to sample derived inhibitors, (vi) reduced amplification time and (vii) direct visual detection. (Tomlinson and Boonham, 2008).

IX. DISADVANTAGES

Besides usefulness, the LAMP assay has some constraints *viz.* (i) reaction products are not of the same size, should not be used as material, (ii) difficult primer design, (iii) unsuitable for less informative gene, (iv) excess indicator affects amplification (v) risk of contamination and (vi) false positive result due to long incubation time (Tomlinson and Boonham, 2008; Soroka *et al.*, 2021).

X. CONCLUSION

The LAMP is highly sensitive, cost effective, accurate, stable and fast than PCR. The LAMP assay design tends to be more challenging than PCR due to requirements for multiple (6) long (~40-45 bp) amplification primers. To get the ideal test performance, a LAMP assay requires optimization and it includes various optimization parameters *viz.*, temperature, enzyme concentration, primer design & concentration, Mg²⁺ concentration and additives. The LAMP assay has the potential to revolutionize diagnosis in resource-limited settings, as it requires minimal equipment and can be performed by non-specialized personnel.

REFERENCES

- [1] Da Silva, S. J. R.; Pardee, K. and Pena, L. (2020). Loop-Mediated Isothermal Amplification (LAMP) for the diagnosis of Zika virus. *Viruses*, 12(19): 1-20.
- [2] Guo, X. G.; Zhou, Y. Z.; Li, Q.; Wang, W.; Wen, J. Z.; Zheng, L. and Wang, Q. (2018). Rapid and reliable diagnostic method to detect Zika virus by real-time fluorescence reverse transcription loop-mediated isothermal amplification. *AMB Expr.*, 8:60.
- [3] Jia, B.; Li, X.; Liu, W.; Lu, C.; Lu, X.; Ma, L. Li, Y. Y. and Wei, C. (2019). GLAPD: Whole Genome Based LAMP Primer Design for a Set of Target Genomes. *Frontier in Microbiology*, 10:2860. doi: 10.3389/fmicb.2019.02860.
- [4] Lee, D.; Shin, Y.; Chung, S.; Hwang, K. S.; Yoon, D.S.; Lee, J. H. (2016). Simple and highly sensitive molecular diagnosis of Zika Virus by Lateral Flow Assays. *Anal. Chem.*, 88:12272-12278.
- [5] Mori, Y.; Kitao, M.; Tomita, N. and Notomi, T. (2004). Real-time turbidimetry of LAMP reaction for quantifying template DNA. *J. Biochem. Biophys. Methods*, 59: 145-157.

- [6] Notomi, T.; Okayama, H.; Masubuchi, H.; Yonekawa, T.; Watanabe, K.; Amino N. and Hase, T. (2000). Loop mediated isothermal amplification of DNA. *Nucleic Acids Research*, 28(12): 1-7.
- [7] Prasannakumar, M. K.; Parivallal, B. P.; Manjunatha, C.; Pramesh, D.; Narayan, K. S.; Venkatesh, G.; Banakar, S. N.; Mahesh, H. B.; Vemanna, R. S. and Rangaswamy, K. T. (2021). Rapid genotyping of bacterial leaf blight resistant genes of rice using loop mediated isothermal amplification assay. *Molecular Biology Reports*, 48: 467-474.
- [8] Priye, A.; Bird, S. W.; Light, Y. K.; Ball, C. S.; Negrete, O. A. and Meagher, R. J. (2017). A smartphone-based diagnostic platform for rapid detection of Zika, chikungunya, and dengue viruses. *Sci. Rep.*, 7:44778.
- [9] Soroka, M.; Wasowicz, B. and Rymaszewska, A. (2021). Loop mediated isothermal amplification (LAMP): The better sibling of PCR? *Cells*, 10(1931): 1-20. <https://doi.org/10.3390/cells10081931>.
- [10] Soroka, M.; Wasowicz, B. and Rymaszewska, A. (2021). Loop-Mediated Isothermal Amplification (LAMP): The Better Sibling of PCR?. *Cells*, 10: 1-20.
- [11] Tomlinson, J. and Boonham, N. (2008). Potential of LAMP for detection of plant pathogens. *Reviews Perspectives in Agriculture, Veterinary Science, Nutrition and Natural Resources*, doi: 10.1079/PAVSNNR20083066