

# METHOD OF PREPARATION OF AMORPHOUS COMPOSITION

## Abstract

Fabricating advanced and sophisticated devices needs materials which are developed by research. In developing the optical and photonic devices, for research need amorphous chalcogenide materials. In this chapter, describe the procedure for deciding the weight/mass/atomic percentage of different elements in an amorphous chalcogenide mixture and then synthesise glass. Some scholars' research has been conducted on glass, pallets, thin films etc. In present chapter describes different methods of deposition of thin film. This chapter describes in deep, the vacuum evaporation in which material either evaporates by resistance heating or by the electron beam. Simultaneously, high-frequency resistance heating, laser ablation, molecular beam epitaxy, sputtering etc have been described.

**Keywords:** Some scholars' research has been conducted on glass, pallets, thin films etc.

## Authors

**Dr. Sharad Pandey**  
Department of Physics  
Chhatrapati Shahu Ji Maharaj University,  
Kanpur.  
Dr Ram Manohar Lohia Mahavidyalaya,  
Kanpur.  
pandey789@gmail.com

## I. INTRODUCTION

This world is very beautiful; we will be able to make the coming future more beautiful with our thoughts, knowledge, and research. In the field of night vision devices, telecommunication, waveguides, optical, components, active and devices, etc amorphous semiconductor have extraordinary importance. Due to that in future metal based communication cable may be replaced by optical fibre based cables.

On the basis of the binding between atoms and molecules, the materials have classified likely two categories such as crystalline and non-crystalline or amorphous. In the crystalline phase, the atoms and molecules are bound up or arranged in a systematic manner. This system is repeated a number of times. So in the crystalline phase of the material, long range order has existed [1].

By the new reports, a phase which does not lie purely in the crystalline phase nor lies in the non-crystalline phase, But this phase lies between the crystalline and the non-crystalline phase. This phase is called poly-crystalline phase. In the poly-crystalline phase, either the medium-range order or the short-range order or both existed. In the category of amorphous materials, both the non-crystalline and the poly-crystalline phases have been included.

The amorphous mixture prepared by melt-quenching technique. But by XRD (X-ray diffraction technique) examination, some time it shows amorphous but shows crystalline. But when thin film deposited on a suitable substrate, this deposited thin film most probably in amorphous phase [2].

**1. Method of preparation of material:** The conventional and convenient method of preparation of amorphous semiconductor mixture/composition is melt quenching. The melt quenching technique has major advantage in comparison to other preparation technique is flexibility of amorphous semiconductor composition. Melt quenching technique has been used to prepare amorphous semiconductor composition. For prepare the amorphous composition, the constitute elements are weighted according to their atomic percentage for preparation of amorphous composition. The elements weights are calculated in the following way for composition  $A_xB_yC_z$ .

For making the amorphous composition, the weighing of the elements according to their atomic percentage amorphous composition is not a compound but it is a mixture. It is necessary first decide the appropriate quantity of elements which are present in the amorphous composition.

In amorphous composition  $A_xB_yC_z$

The atomic weight of A is u amu

The atomic weight of B is v amu

The atomic weight of C is w amu

So the atomic weight of  $A_xB_yC_z = (A \times u + B \times v + C \times w)$  amu

For the preparation of S gm composition

Element A required =  $(A \times u / (A \times u + B \times v + C \times w)) \times S$  gm

Element B required =  $(B \times v / (A \times u + B \times v + C \times w)) \times S$  gm

$$\text{Element C required} = (C \times w / (A \times u + B \times v + C \times w)) \times S \text{ gm}$$

After weighing the elements, these elements are filled in quartz ampoule. Before filling the weighing elements in quartz ampoule, first, the quartz ampoule is washed with trichloro ethylene (TCE), then washed with acetone and methanol, and finally washed properly with distilled water. After washing the quartz ampoule dried properly. The purpose of washing and drying the quartz ampoule is removed absorbed water and contamination from quartz ampoule.

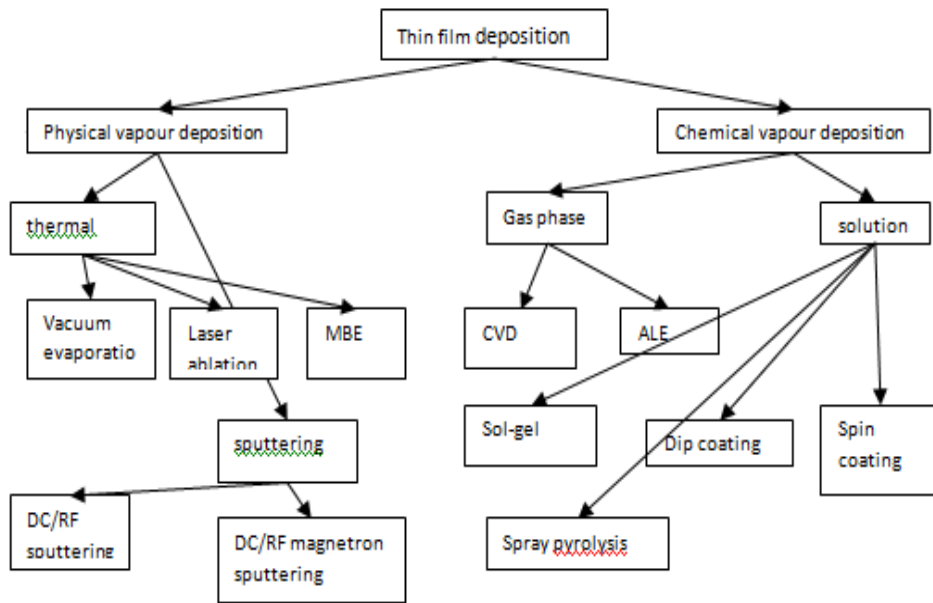
In the vacuum environment, the loaded quartz ampoules are sealed with the help of LPG (liquefied petroleum gas) + oxygen flame. These sealed ampoules put into the rocking furnace. The temperature inside the rocking furnace increases at rate of 3 – 4 °C/min and reaches up to 900 °C/1000 °C. At this temperature all elements comes into liquid state and this process continue for next 9 to 10 hours and rocking simultaneously. The purpose of long time heating and rocking is making homogeneous melt [3].

After completing this process, pulled out the ampoules from the furnace and quenched into the ice cold water. After that break the quartz ampoule and recovered the ingot of amorphous composition.

2. **Thin Film:** A thin film is a layer of material ranging from fraction of a nanometre to several micrometres in thickness. A thin film can be created by condensing atomic/molecular/ionic species of matter. The fabrication of thin film on a single substrate is done by deposition of individual atomic/molecular/ionic species. The thin film technology uses for making electronic devices, instrument hard coatings for decoration, prevent rust and external damages from environment etc. This technology uses more than fifty years. It is well established material technology. It is old as well as current material technology. The research is going on to develop advanced technology for thin film deposition.
3. **Thin film preparation technologies:** On the nature of deposition processes the methods of thin film preparation broadly divided into two groups
  - Physical Methods
  - Chemical Methods
  - **Physical Methods:** If the vapour created by physical means from bulk material without involving a chemical reaction the methods is known as physical methods. We technically have known as physical deposition processes.

The physical deposition processes include vacuum evaporation, laser ablation, molecular beam epitaxy (MBE) and sputtering etc.

- **Chemical Methods:** If material deposited on the substrate is the product of chemical reaction the methods is known as chemical methods. We technically have known as chemical deposition processes. The chemical deposition processes include chemical vapour deposition (CVD), atomic layer epitaxy (ALE), sol-gel, dip coating, spin coating, spray pyrolysis etc. (In Fig. 1.1)



**Figure 1:** Film deposition technology

**4. Vacuum Evaporation (Material evaporated by resistance heating):** In vacuum evaporation process the source material evaporated in a vacuum chamber. The pressure inside the vacuum chamber is below than  $10^{-6}$  mbar. The evaporated particles of source material condense on the surface of the substrate and form the thin film.

Now the question is arises why this process done in the vacuum chamber. The main reasons behind this

- At the high vacuum the contamination present inside the chamber at very low level. So the film deposited on the substrate of very high purity.
- When pressure decreases inside the chamber the mean free path of the particles of source material increases. So particles evaporated from source material easily reach to the substrate and condenses on its surface.

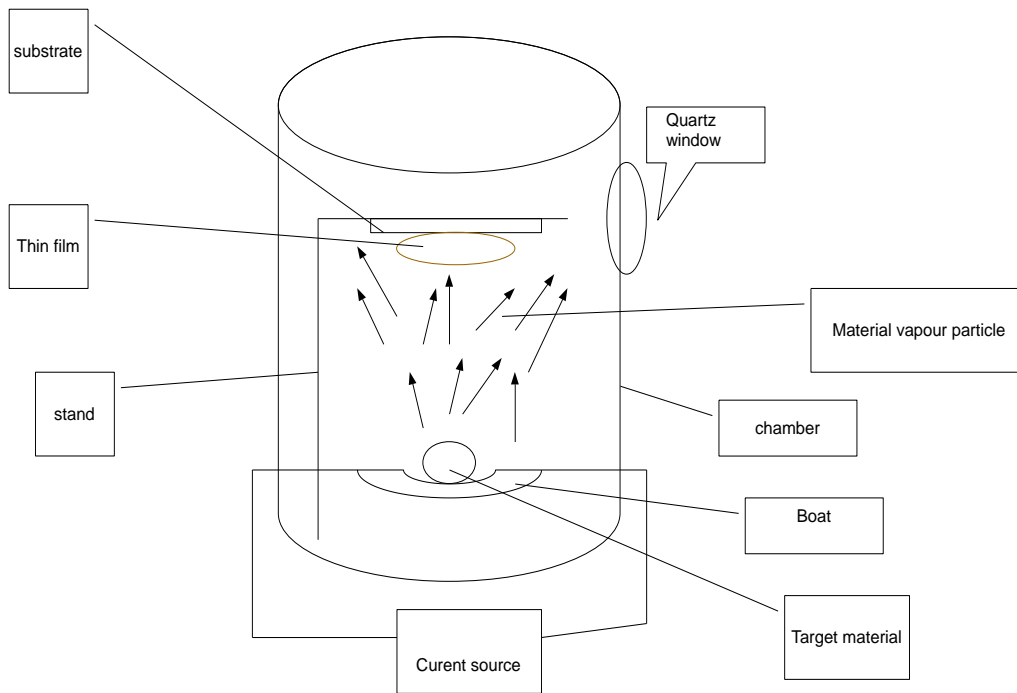
$$\text{Mean free path} \propto \frac{1}{\text{PRESSURE}}$$

For heating the source material inside the vacuum evaporation chamber used resistance heating, high frequency induction heating, electron beam etc. the evaporated particles of source material travel through reduced pressure environment inside the chamber and condenses on the surface of substrate.

**5. Principle:** In this process the source material converted into vapour by heating the boat. Boat is the metallic strip or crucible in which source material kept for vaporize. This vapour condenses on the surface of the substrate and thin film formed. For heating the boat or vaporize the target material one of the method used [4, 5].

The electric current passed through the boat. When electric current passed through it due to the heating effect of electric current the boat become heat up. At suitable amount

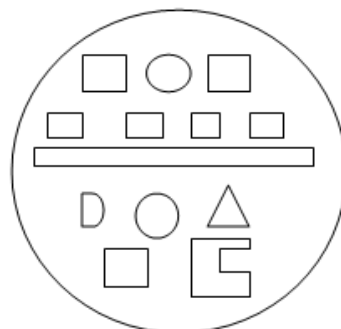
of current when target material starts vaporize make current stable and wait till all material convert into the vapour. (Fig. 1.2)



**Figure 2:** inside view of vacuum chamber

- 6. Description of Apparatus:** The apparatus have three parts upper part (Roughing Chamber), control panel and lower part (Backing Chamber). In upper part have a bell jar shaped part which made by metal. This bell jar has a quartz window. Through this quartz window we can see the activities inside the chamber. In the lower side of the upper chamber has a boat stand. Boat is a metallic crucible made by tungsten/molybdenum metal or other suitable material.

In upper part of the upper chamber has a mask stand. On the mask stand put the mask. On the mask we put the substrate on which the thin film deposited. Mask is the metallic plate having empty spaces according to shape of the film to be deposited. (Fig. 1.3)



**Figure 3:** shape of mask

The control panel is side by side of the upper part of the unit. The vacuum inside of roughing chamber, backing chamber, vacuum at hole, evaporation rate/deposition rate, intensity of the current through the boat and other parameter can be read on the corresponding display.

The rotator vacuum pump, molecular vacuum pump, cooling unit, electrical cables and electronic circuit etc. all are mounted in the lower chamber. This chamber opens only for the repairing and maintenance purpose.

- 7. Procedure of thin film deposition:** Initially opens the cover of the vacuum chamber. Put the target material in the boat and the substrate on the mask. Now close the cover of the vacuum chamber. Before starting the process of film deposition, first start the water supply. This water flow in the lower chamber of the deposition unit through helix shaped metallic tubes. During the deposition process a lot of heat generated due to running of rotator pump, molecular pump and other process. Every part of the unit work with its full efficiency it is necessary to remove this heat. To remove this heat must start the water supply initially when use the thin film deposition unit.

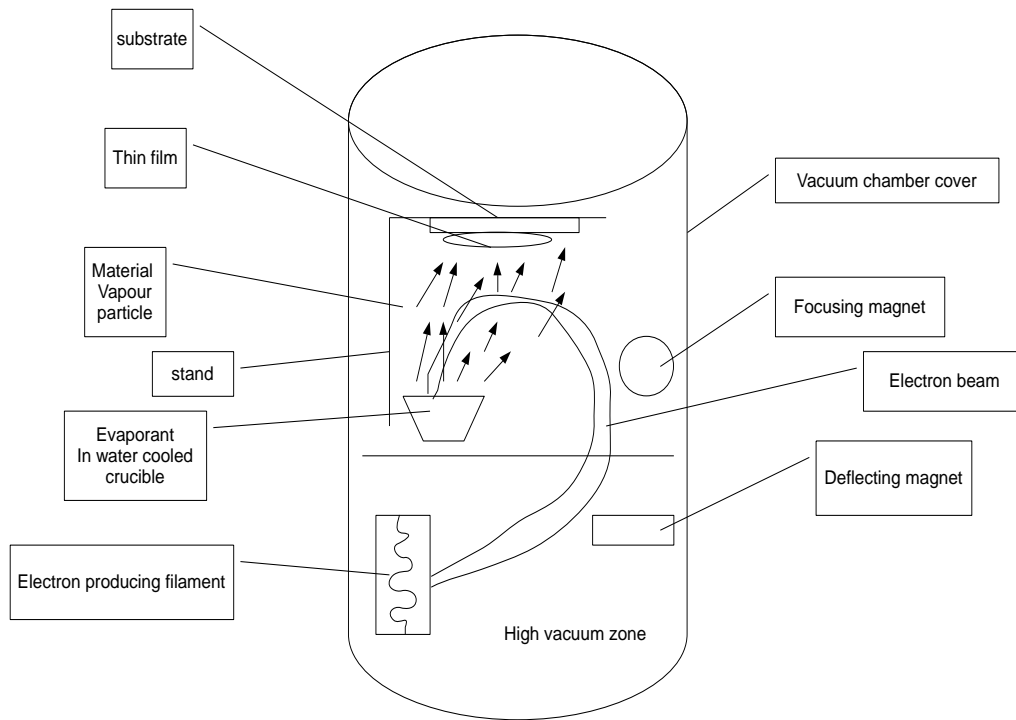
First start the rotator pump, this pump is of low capacity and generate vacuum up to  $2 \times 10^{-2}$  mbar inside the vacuum chamber. Due to this all big particles remove from the vacuum chamber. After this starts the molecular pump, this pump of high capacity this can generates the vacuum of  $2 \times 10^{-6}$  mbar and lower. While achieve this vacuum, it means chamber prepared for deposition of film.

Now start flowing current through the boat simultaneously see the inside activity through quartz window. Gradually increase the value of current and observe when target material starts to evaporate. At suitable amount of current stable the value of the current and wait till all material converts into the vapour. This vapour deposited on the surface of the substrate which is placed on the mask. When all material evaporated decreases the value of the current to zero. After that stop the molecular pump and then rotator pump. Open the chamber cover and collect the substrate. The thin film deposited on the substrate.

- 8. Vacuum Evaporation (Material evaporated by the electron beam):** In electron beam evaporation method the electron beam concentrate a large amount of heat in very small area of the target material so that high rates of deposition are possible. The evaporation processes do in a vacuum chamber where pressure is  $10^{-6}$  mbar or less [7].

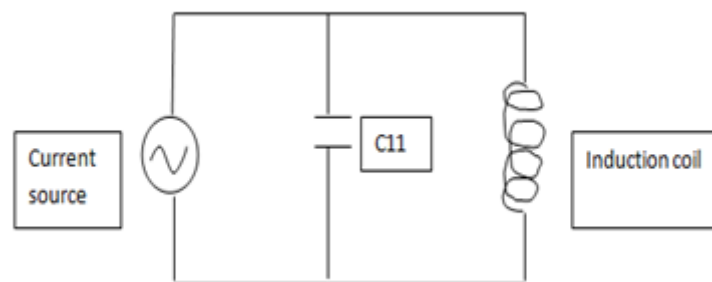
A wide variety of materials such as tungsten, platinum and alloy can be evaporated by this method. The process is begun under a vacuum of  $10^{-6}$  mbar or less. A tungsten filament is heated inside the electron gun and produce electron. These electrons form an electron beam which deflected, accelerated and focussed toward the target material by means of magnetic and electric fields. The electron gun assembly locate outside the evaporation zone. The reason is avoid the contamination from evaporant. When electron beam strike the target surface the kinetic energy of electrons transformed into thermal energy. This energy vaporise the target material. The energy level achieved in this manner quite high often more than several millions watts per square inch. Due to the intensity of the heat generated by the electron beam the evaporant holder must be

water cooled to prevent it melting. The power supply for this operation is a high voltage D.C. power supply typically 10 to 30 kilovolts. (Fig.1.4)

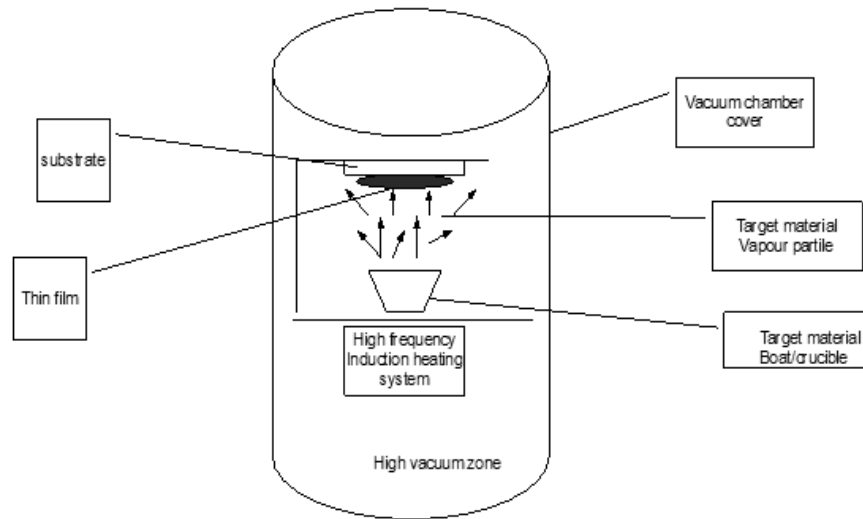


**Figure 4:** inside view of vacuum chamber of electron beam deposition unit

**9. Vacuum Evaporation (Target Material Vaporises by High Frequency Induction Heating):** In high frequency induction heating method the target material in the boat evaporated by this method. This method is coupling of electromagnetic and thermal phenomena.



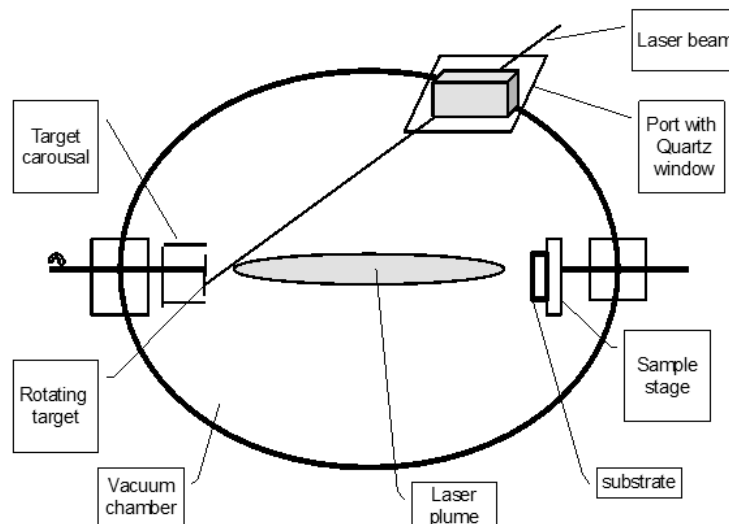
**Figure 5:** Arrangement of Heating Target Material In HFIH



**Figure 6:** Inside view of vacuum chamber in high frequency induction heating

Within the vacuum chamber the system of stand and mask similar as the discussed above in 1.5.2. The difference is method of converting the target material into vapour. The heat has supply to the target material by the induction furnace. The induction furnace is just below the boat/crucible in which target material kept. The crucible has made by the graphite. The crucible achieved the temperature 1500 degree Celsius and coils maintain their function without any deformation without any cooling system during the operation. If induction coils with cooling system then crucible achieves the temperature 2000 degree Celsius. The system of induction heating system is as in Fig. 1.5. The inside arrangement within the vacuum chamber in high frequency induction heating is as Fig. 1.6.

**10. Laser Ablation:** Pulsed laser ablation based technique or pulsed laser deposition is an improved thermal process used for deposition of alloys or compound with a controlled chemical composition.



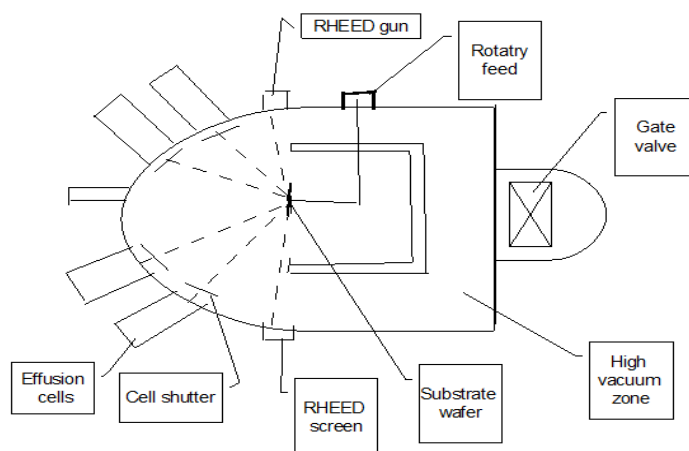
**Figure 7:** Inside view of vacuum chamber in pulsed laser deposition



In laser deposition, a high power pulsed laser (typically 108 watt per square cm) is irradiated onto target of source material through quartz window. A quartz lens used to increase the energy density of the laser on the target source. Atoms that are ablated or evaporated from the surface of target material are collected on nearby substrate surface to form thin film. The target material is locally heated to the melting point, melted and vaporizes in vacuum [7].

The pulses of laser energy vaporises the target material. This vapour is contain neutral particles, ions and electrons etc. This vapour known as a laser produced plasma plume. This plasma plume expands rapidly away from the target surface with velocity 106 cm per second in vacuum. When this plume condenses on the substrate the first layer of the film deposited. Film growth occurs on the substrate upon which some of the plume material recondenses. The variables which effect the film deposition and manipulate the film properties is laser fluence, background gas pressure and substrate temperature.

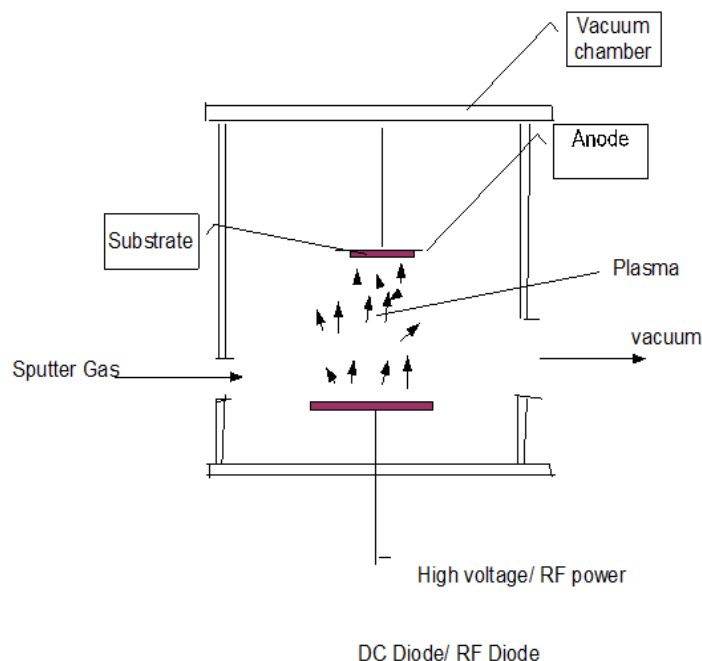
**11. Molecular Beam Epitaxy:** Molecular beam epitaxy is an evaporative method. This growth technique provides film of extraordinary good quality for the research purposes. The rate of growth of film is very low compared to other methods. In MBE, the deposition of a thin film can be accurately controlled at the atomic level in ultra high vacuum of order  $10^{-9}$  torr. A substrate is placed in the ultra high vacuum. It is sputtered with low energy ion beam to remove surface contamination [8].



**Figure 8:** Inside view of molecular beam epitaxy chamber

The deposition rate is typically 3000 nm per hour that film grows epitaxially. The ultra high vacuum environment and absence of carrier gases results in the highest achievable purity of the grown films. The target materials are heated in separate Kundsens effusion cells until they begin slowly sublime. The gaseous element condenses on the wafer. The evaporated atoms does not react each other or vacuum chamber gases until they reach the wafer due to the log mean free paths of the atoms. During the operation, reflection high energy electron diffraction (RHEED) is used to monitoring the growth of the layers. Computer controlled shutter in front of each furnace allowing precise control of each layer.

**12. Sputtering:** Sputtering is the ejection of surface atoms by momentum transfer by bombarding of slow ion beam energy. Sputtering is the non thermal physical process. Sputtering is utilized for etching process as well as deposition process depending upon ion energy [9].



**Figure 9:** inside view of sputtering chamber

**13. DC Sputtering:** The DC sputtering system is composed of a pair of planar electrodes. One of the electrodes is cold cathode and other is the anode. The front surface of the cathode is covered with the target material to be deposited. Sputtering chamber filled with sputtering gas typically argon gas at  $4 \times 10^{-2}$  torr. The glow discharge is maintained under the application of DC voltage between the electrodes. The argon ions generated in the glow discharge are accelerated toward the cathode and hits the target surface and result in the sputtering of the target. When argon ions reached the target surface it converted into the argon atom by capturing the stray electrons on the surface of the target or the surrounding. The sputtered atoms from the target then fall on the heated substrate resulting in deposition of the thin film.

## REFERENCES

- [1] A. Zakery, S.R. Elliott, Optical properties and applications of chalcogenide glasses: A review, *J Non-Cryst Solids*. 330 (2003) 1–12. doi:10.1016/j.jnoncrsol.2003.08.064.
- [2] B.D. Cullity, S.R. Stock, *Elements of X-Ray Diffraction*, Third, Pearson Education Limited, 2014.
- [3] Beneš, M., Pekárek, T., Beránek, J., Havlíček, J., Krejčík, L., Šimek, M., Tkadlecová, M., & Doležal, P. (2017). Methods for the preparation of amorphous solid dispersions – A comparative study. *Journal of Drug Delivery Science and Technology*, 38, 125-134. <https://doi.org/10.1016/j.jddst.2017.02.005>.
- [4] R. Chauhan, S. Pandey, S.G. Prasad, Effect of 80 MeV Si swift heavy ion irradiation on Ge<sub>22</sub>Se<sub>78</sub> thin films for optical applications, *Chalcogenide Lett.* 15 (2018) 267–279.
- [5] S. Pandey, R. Chauhan, Contribution of 80 MeV silicon swift heavy ion irradiation for reforming of optical and structural properties of amorphous Ge<sub>23</sub>Se<sub>62</sub>As<sub>15</sub> thin films for telecommunication and sensing applications, *J Non-Cryst Solids*. 554 (2021) 120597. doi:10.1016/j.jnoncrsol.2020.120597.

- [6] Arya, S., & D'Amico, A. (1988). Preparation, properties and applications of boron nitride thin films. *Thin Solid Films*, 157(2), 267-282
- [7] Sasi, B., & Gopchandran, K. (2007). Preparation and characterization of nanostructured NiO thin films by reactive-pulsed laser ablation technique. *Solar Energy Materials and Solar Cells*, 91(15-16), 1505-1509.
- [8] Takahiko Kawaguchi *et al* 2009 *Appl. Phys. Express* **2** 093002.
- [9] Gregoire, J. M.; Lobovsky, M. B.; Heinz, M. F.; DiSalvo, F. J.; van Dover, R. B. (26 November 2007). "Resputtering phenomena and determination of composition in codeposited films". *Physical Review B*. **76** (19): 195437.

