

# CONVENTIONAL VERTICAL AXIS WIND TURBINE SYSTEM PERFORMANCE AND EFFICIENCY IMPROVEMENT THROUGH TURBINE MODIFICATION TO INCOPERATE THE PERMANENT MAGNET PROPELLING PHENOMENON

## Abstract

The world's rapidly increasing population and the quick increase in people's living standards are currently the two main sources of the energy problem. Because of this, there is an energy crisis that has an impact on everything in the globe, and energy prices are increasing. The earth's crust, the outermost layer of the planet's surface, is where fossil fuels have mostly been found. These fuels were naturally created from decomposed plants and animals. These broken down parts will include a lot of carbon and hydrogen, and they will be burnt to produce energy. However, coal, nuclear power, and hydropower are the main sources of electricity production, with a little contribution from the renewable energy sector. Many individuals use natural gas for heating. Biomass, mainly wood or decayed animal waste, is used for heating and cooking. Oil is particularly adaptable since it powers almost all moving objects. If existing levels of oil production are maintained until they are exhausted, the vast majority of people are aware that oil and gas will increase in price and become scarce during their lifetimes. It is widely accepted that the energy we now use will not be sufficient to fulfill the demands of all people on the globe in the future, necessitating the need for cleaner, more abundant alternative energy sources, which may also take the form of hybrid energy.

Renewable energy sources will undoubtedly gain in popularity. After that, we can choose between a planned and an arbitrary transition. Because modern civilizations depend on cheap, abundant energy to function, it is critical for human civilization to develop alternative energy

## Authors

### **Sandesh Hegde**

Research Scholar

Department of Mechanical Engineering

Srinivas Institute of Technology

Mangalore, India.

[sandeshh.hegde92@gmail.com](mailto:sandeshh.hegde92@gmail.com)

### **Dr. Ramachandra C G**

Professor

Department of Mechanical Engineering.

Presidency University

Bangalore, India

[ramachandra.cg@gmail.com](mailto:ramachandra.cg@gmail.com)

### **Dr. Nagesh S N**

Assistant Professor

Department of Mechanical Engineering

Ramaiah Institute of Technology

Bangalore, India

[snnagesh80@gmail.com](mailto:snnagesh80@gmail.com)

### **Dr. Prashanth Pai M**

Associate Professor

Department of Mechanical Engineering

PA College of Engineering

Mangalore, India

[shanth.pai@gmail.com](mailto:shanth.pai@gmail.com)

CONVENTIONAL VERTICAL AXIS WIND TURBINE SYSTEM PERFORMANCE  
AND EFFICIENCY IMPROVEMENT THROUGH TURBINE

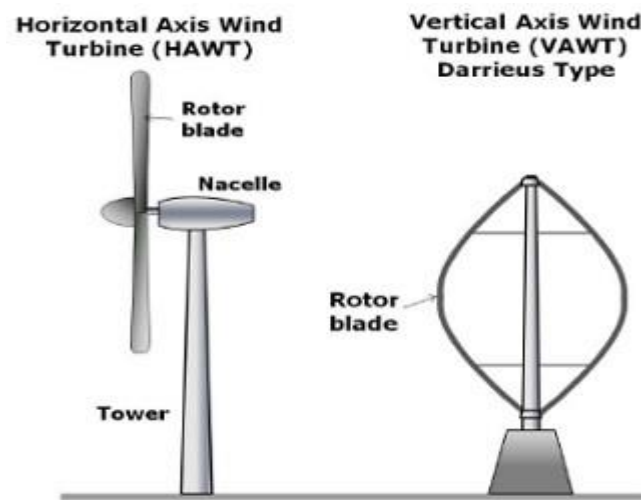
## MODIFICATION TO INCOPERATE THE PERMANENT MAGNET PROPELLING PHENOMENON

sources that are ecologically friendly, economical, and sustainable. Wind power may offer an effective answer to the world's energy crisis. It is a perfectly safe, reasonably priced, and ecologically beneficial source of clean and green energy. The next choice is a planned or random transition. It is essential for human civilization to develop sustainable, cost-effective, and environmentally friendly alternative sources of energy since modern civilizations depend on cheap, abundant energy to thrive. Wind power might provide a cost-effective answer to the world's energy problems. It is a cost-effective, entirely safe, and ecologically responsible source of clean and green energy. Given the current situation, air may appear unimportant to anybody or everyone. We all know that the globe has an uneven surface due to its form, which means that sunrays may impact the surface at different points along the uneven surface with varying intensities. As a result, there is an accompanying degree of uneven heating of the earth's surface, which changes some of the air pressure there. It then results in wind. These air molecules' kinetic energy is nothing more than wind energy. A wind turbine is a mechanical device that converts kinetic energy from the air surrounding it into the necessary kind of mechanical energy. In this study, we concentrated on the repelling characteristics of items that are persistently magnetized and have identical poles. Here, magnetic propulsion's inherent properties are employed as energy sources. Because of the addition of such elements as magnetic repulsion, our VAWT system will function better under conditions with lower wind speeds as well. When wind energy is used as an additional source of energy in a VAWT, the magnets will provide a repulsive force that will contribute various types of kinetic energies to the wind turbines as they transform wind energy's kinetic energy into the necessary mechanical power.

**Keywords:** Magnets, Vertical Axis Wind Turbines, Hybrid Energy, and Renewable Energy Sources

## I. INTRODUCTION

Since ancient times, people have used the wind to power sailboats and mills, and architects have exploited the wind to drive natural ventilation in buildings. However, the energy sector had an enormous boom during the start of the 1980s, which was particularly noticeable in the wind energy sector. As a result, in the present property energy sector, they will furthermore play a significant part, inside a property energy bank, under the term of hybrid energy source, in addition to hydro power, alternative energy, and wind energy. The wind's mechanical energy is transformed into the necessary type of energy by the mechanical system that supports the turbine system. Now, this mechanical power can be used to move or operate another system, or it can be used to turn the generator shaft to produce energy. The change in air pressure delivered to a windmill mechanism causes the blades to gain velocity. The shaft that holds the spinning blades will begin to rotate cylindrically. With the use of a generator attached to the shaft, the mechanical energy that was previously utilized to power other machines straight from the shaft was now turned into electrical energy.

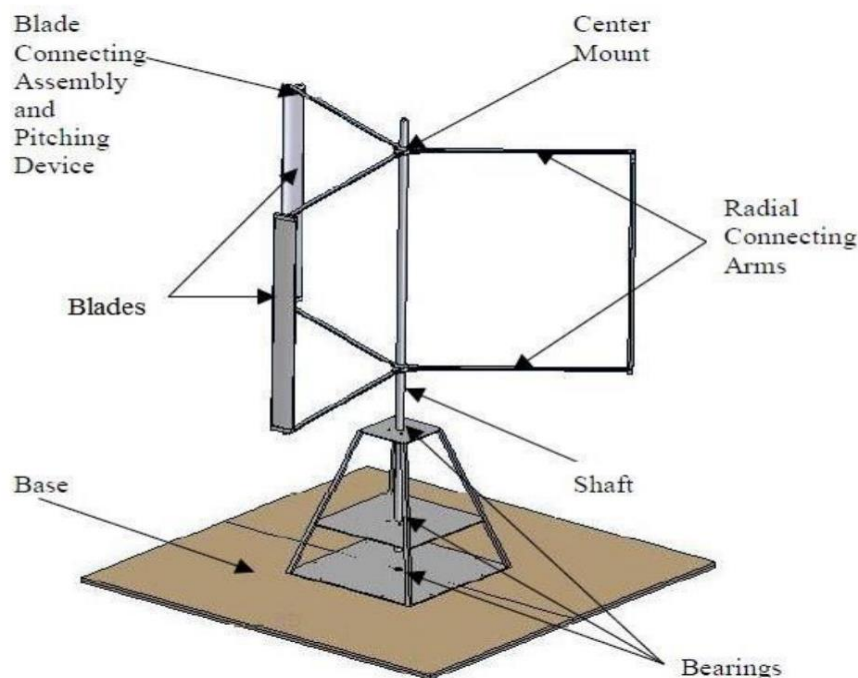


**Figure 1: Alternative Shaft and Rotor Configuration**

There are mainly two families of wind turbines as shown in figure 1; the majority of these have a horizontal shaft with connected blades. Moreover, a shaft-mounted electric generator, these wind turbines have a horizontal axis, thus the name. The most common configuration is three blades, and they spin "upwind" at the top of a tower so they can blades face the wind. The HAWT is the most frequent configuration for a turbine. A significant pedestal supports the turbine components, including the propellers, above the ground. It depends on the individual whether or not they change the landscape. There is no denying, however, that having their systems located at a height is a drawback when service is required. They also require a mechanical yaw mechanism to be positioned such that their horizontal axis is perpendicular to and facing the wind. Because the swept area (or rotor's diameter) and potential power output are associated, more power is required for larger diameters. Since the blades are subject to substantial thrust and torque forces, the size is limited by blade strength.

The vertical axis machine is another sort of device that has a series of long, curved blades on a vertical shaft and is formed like an eggbeater.

Because they are omnidirectional, these turbines don't need to be placed in a certain way so that they face the wind in order to work. Due to the predicted advantages of omnidirectionality, vertical axis designs were taken into account at the early stages of development. Figure 2 illustrates this general classification of wind turbines. The primary rotor shaft is positioned vertically because the vertical plane of rotation for vertical-axis wind turbines (VAWTs) is vertical. Vertical-axis turbines are an earlier, less well-known kind of wind turbine. These blades are straight. A vertical-axis wind turbine is a specific type of vertical-axis wind turbine that provides a number of potential advantages over the frequently utilized conventional horizontal-axis turbines today. Because VAWTs don't require a yaw control system, they may be directed facing the wind. These are particularly useful in areas where the wind's direction is erratic or there are significant obstacles, such as large residences, trees, or other structures. Additionally, VAWTs may be positioned near to the ground without the need for a tower structure, which makes it easier to reach electrical components. A generator can also be installed close to the ground, which makes it easier to maintain the moving parts. And unlike HAWT, begins to rotate in lower wind speed conditions.



**Figure 2: VAWT Systems Configuration**

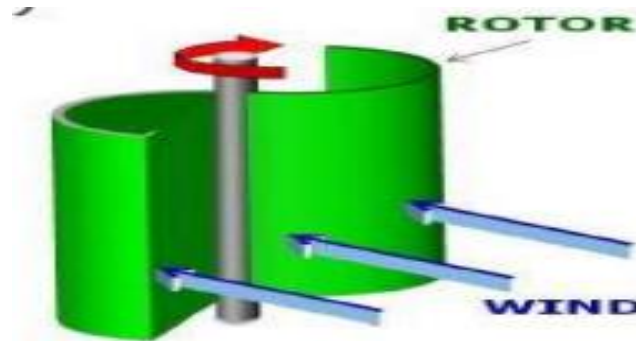
The goal of our research is now the creation of a VAWT powered by a permanent magnet. This system can operate in a variety of wind-speed environment circumstances thanks to hybrid energy technology of permanent magnets. In this study, we evaluate the performance of vertical axis wind turbines in the PM design in comparison to the traditional VAWT system that they will eventually replace.

## II. WIND SAIL DESIGN

The wind turbines in this case are mechanical constructions with a shaft, blade, and supporting components. When the give system is installed and exposed to an area where air is moving, the air may come in touch with the rotating blades and change the pressure. As a result, the rotor starts to move in the carry's direction. Here, wind mechanical energy is then transformed into the required form of energy and delivered through the shaft to a generator or alternative system after the rotor parts of the supplied system start to revolve. In the family of wind turbines, there are primarily two sub-systems: the horizontal axis and the vertical axis. In our, both the investigation, we decided to use a vertical axis wind turbine system with magnetic propulsion. In a VAWT configuration rotating plane and the rotating shaft are vertical. The rotating shaft itself then resembles a cylinder. The VAWT Systems are the oldest and least popular members of the family of turbines. Additionally, this design has a number of advantages over the more popular horizontal-axis turbine configuration. The VAWT's Structure essentially has two subtypes, which are as follows:

- Darrieus Model.
- Savonius Model.

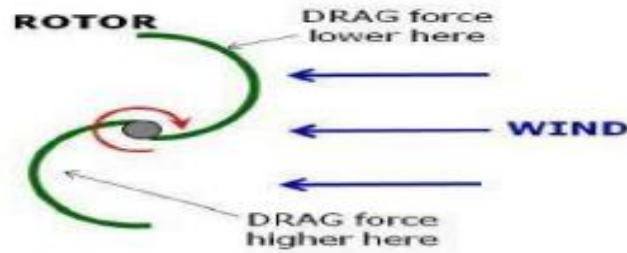
The drag-type VAWT structure used by the Savonius-based turbine system in the VAWT system family functions similarly to a pedal boat on water. The inventor of this method is S.J. Savonius. Over time, a bucket, plate, or cup used as a propelling mechanism to create the drag-based Savonius structure as shown in figure 3.



**Figure 3: S-Shaped Savories Type VAWT Model**

The S-model rotary blades are referred to as Savonius type rotor devices in this article. These pull-type VAWT systems offer a particularly high starting torque and self-starting qualities in comparison to lift-based systems. When investigating the two main sub types of VAWT system rotor components, we eventually decided to base our foundation on the Savonius design with a few minor modifications.

CONVENTIONAL VERTICAL AXIS WIND TURBINE SYSTEM  
 PERFORMANCE AND EFFICIENCY IMPROVEMENT THROUGH  
 TURBINE MODIFICATION TO INCOPERATE THE PERMANENT MAGNET PROPELLINPHENOMENON



**Figure 4: Scoop will be created on upper half of Savonius Model**

The addition of magnetic repulsion properties between the moving and stationary portions of turbines is the primary deviation from the basic Savonius subsystem idea. The upper half of the blades of the turbine will experience scoops as a result of this repulsion, and it is necessary to remove these scoops from the turbine and to create a smoother torque as the rotor rotates [4]. We modified our design somewhat in contrast to our standard Savonius turbine model [2] by altering the rotor blade's top to base's bending shape. This is done by swirling, in accordance with our design criteria, a group of triangular faces cut from an aluminium sheet element from the top to the bottom of the rotor blade. The finished modified Savonius design is shown in Figures 5.



**Figure 5: A prototype of modified turbine model**



**Figure 6: PM-VAWT Model vs. Conventional VAWT Model**

### III. PERMANENT MAGNET SELECTION AND ITS CHARACTERISTICS – ENERGY BANK

Magnets are objects that emit a magnetic field or force field that either attracts or repels specific materials like nickel or iron. Since not all magnets naturally contain the same elements, they can be categorized into different groups based on their composition and magnetism-producing mechanisms. Permanent magnets retain their magnetic attraction even after being magnetized.

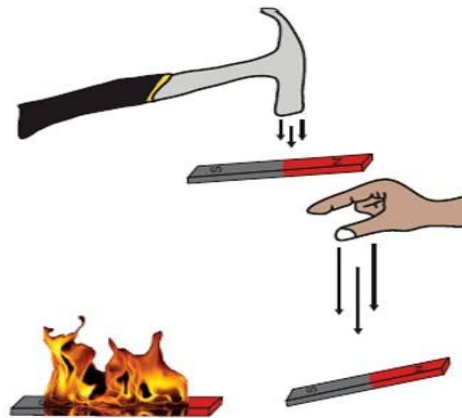


Figure 7: Magnetic Property Loss

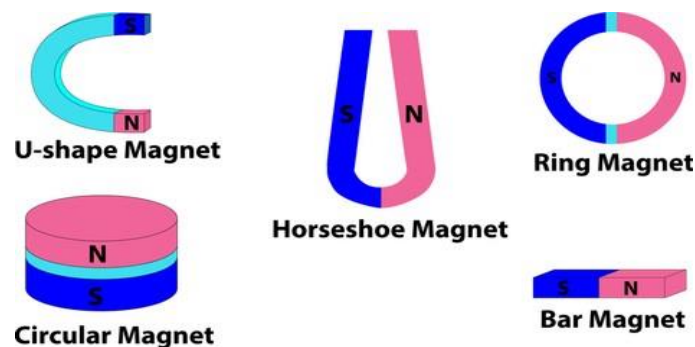
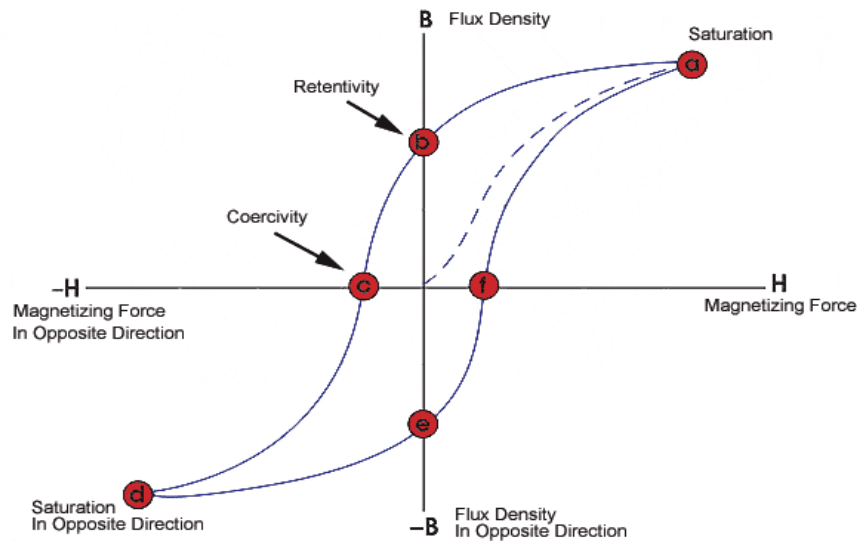


Figure 8: Types of magnets based on shape

Temporary magnets are substances that behave like permanent magnets in the presence of a magnetic field, but lose their magnetic qualities when the magnetic field is gone. The four primary kinds of permanent magnets are ceramic/ferrite, Alnico, Samarium cobalt (Sm-Co), and Neodymium Iron Boron (Nd-Fe-B). Unless it is physically harmed by heating or hammering, as shown in Figure 7, permanent magnets are energy storage devices that will never lose their magnetic properties of attraction and repulsion. By pressing sintered iron oxide with barium or strontium carbonate, ceramic/ferrite permanent magnets may be made quickly and inexpensively. However, due to their frequent fragility, these magnets must be honed using a diamond wheel. They are among the magnets that are most often used; they have a strong magnetic field and are challenging to demagnetize.

CONVENTIONAL VERTICAL AXIS WIND TURBINE SYSTEM  
 PERFORMANCE AND EFFICIENCY IMPROVEMENT THROUGH  
 TUBINE MODIFICATION TO INCOPERATE THE PERMANENT MAGNET PROPELLINPHENOMENON

Alnico magnets get their name from the first two letters of each of its three main ingredients: cobalt, nickel, and aluminium. They are easily demagnetized despite having excellent temperature tolerance, and in some applications, ceramic and rare earth magnets are occasionally used in their place. Both casting and sintering are methods that may be used to create them, and each one results in magnets with different characteristics. Sintering produces better mechanical properties. Casting results in more energetic products and allows for the creation of more complex magnet design elements. Sm-Co magnets are incredibly strong and difficult to demagnetize. They are extremely thermal and oxidation resistant and can withstand temperatures of up to 300 °C. Neodymium Iron Boron (Nd-Fe-B), a magnetic alloy made of rare earth materials, possesses a potent coercive force. The high product energy level allows them to be manufactured often in small, compact quantities. Nd-Fe-B magnets have poor mechanical strength, are typically brittle, and have little corrosion resistance; nonetheless, if left uncoated, they will suffer from these drawbacks. If they get a nickel, iron, or gold plating treatment, they can be used in a variety of applications. They are incredibly strong magnets that are difficult to demagnetize. One or more variables that might affect a magnet's stability include time, temperatures, reluctance changes, adverse stress, fields, shock, radiation, and vibration.



**Figure 9: BH Curve Model**

Magnet design is based on the B-H curve, also known as the hysteresis loop, of each magnet material. The cycle of a magnet in closed circuit is shown on this graph as it is exposed to an external magnetic field, brought to saturation, demagnetized, saturated in the other direction, and finally demagnetized once again. The "Demagnetization Curve," or second quadrant of the B-H curve, illustrates the practical applications of permanent magnets. A permanent magnet will have a single, static working point if the air-size gap's is maintained and all external fields are kept constant. The device must be designed to account for this behavior as, in the absence of it, the working point will deviate from the demagnetization curve.

**Table 1: Magnetic Flux Density chart**



CONVENTIONAL VERTICAL AXIS WIND TURBINE SYSTEM  
PERFORMANCE AND EFFICIENCY IMPROVEMENT THROUGH  
TUBINE MODIFICATION TO INCOPERATE THE PERMANENT MAGNET PROPELLINPHENOMENON

Material	BH <sub>max</sub>	Tcoef of Br	T <sub>curie</sub>	B <sub>r</sub>	H <sub>c</sub>	T <sub>max</sub>
<b>Ceramic</b>	3.5	-0.20	460	3900	3200	300
<b>Alnico</b>	5.5	-0.02	860	12500	640	540
<b>Sm-Co</b>	26	-0.04	750	10500	9200	300
<b>Nd-Fe-B</b>	40	-0.12	310	12800	12300	150

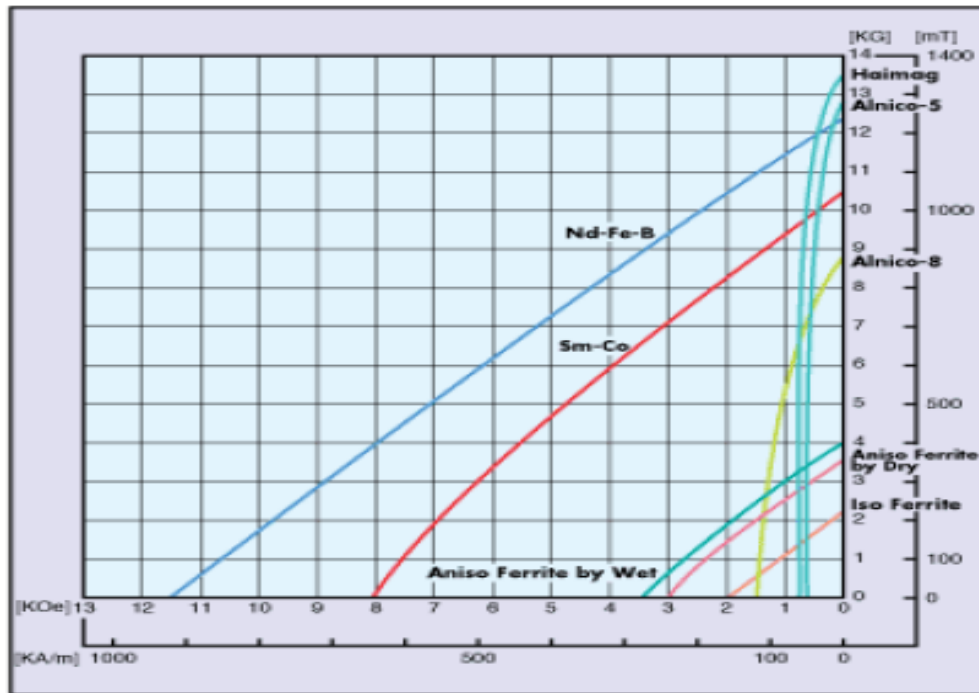
The three most important characteristics of the B-H curve are the maximum of the product of B and H and the intersection with the B and H axes (at Br for residual induction and Hc for coercive force, respectively) (BHmax - the maximum energy product). The maximum flux that a magnet may produce in a closed circuit is denoted by the symbol Br. In actual use, permanent magnets can only come close to this.

The magnetic property loss that occurs when a magnet is exposed to an outside magnetic field is denoted by the symbol Hc. The value of the product of B and H as well as the energy density of the magnetic field into the space around the magnet are both referred to as "BHmax." As the cost of the product increases, the volume of the magnet becomes less necessary. The temperature sensitivity of the B-H curve should also be considered when designing. This phenomenon is examined in more detail in the section titled "Permanent Magnet Stability". The flux density ( $B=I/A$ ), which is used to build a B-H curve, is computed by dividing the magnet's total flux by its pole area (A).

The total flux consists of the internal flux of the magnet produced by the magnetizing field (H) and the intrinsic ability of the magnet material to produce extra flux due to the orientation of the domains. As a result, there are two components to the flux density of the magnet: one created by the applied H and the other by the ferromagnetic materials' natural ability to produce flux. The intrinsic flux density is represented by the symbol Bi when the total flux  $B = H + Bi$  or when  $Bi = B - H$ .

When there is no external magnetizing field, the magnet operates properly in the second quadrant, where H has a negative value. Because H is routinely used to refer to a positive integer despite being formally negative,  $Bi = B + H$  is the accepted formula. It is possible to plot both a typical B-H curve and an intrinsic B-H curve. The force that manifests when the intrinsic curve crosses the H axis is known as the intrinsic coercive force, or Hci. High Hci values point to a naturally stable magnet material.

It is possible to deduce the intrinsic curve and the normal curve from one another. When a magnet is operated statically and without the aid of any external fields, the normal curve is sufficient for design purposes. To evaluate how the material's intrinsic properties change in the presence of external fields, the normal and intrinsic curves are utilized.



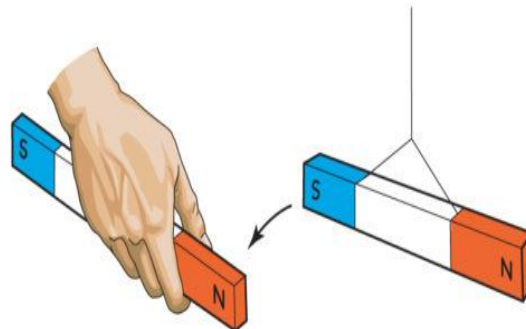
**Figure 10: Commercial Permanent Magnet BH Curve.**

The Nd-Fe-B has a very attractive magnetic characteristic, offering better features like, it offers a high magnetic field flux density, provides high magnetic field strength in given condition, and also has the capacity to resist demagnetization in extreme conditions, according to the BH Curve of Magnet Materials. Consequently, it was decided to employ an Nd-Fe-B (Neodymium Iron Boron) magnet.

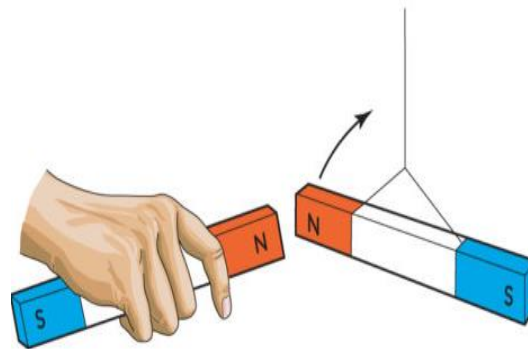
Permanent magnets may be utilized to capture kinetic energy from the magnetic propelling phenomena and other magnetic properties, such as the repulsion of like polarities of magnets, can be exploited as a supplementary energy source [5].

Nd-Fe-B magnets can be classified as sintered or bonded depending on how they were made [8]. In many uses in modern goods that require strong permanent magnets, such as hard disc drives, magnetic fasteners, and electric motors in cordless tools, they have supplanted other types of magnets.

CONVENTIONAL VERTICAL AXIS WIND TURBINE SYSTEM  
PERFORMANCE AND EFFICIENCY IMPROVEMENT THROUGH  
TURBINE MODIFICATION TO INCOPERATE THE PERMANENT MAGNET PROPELLINPHENOMENON

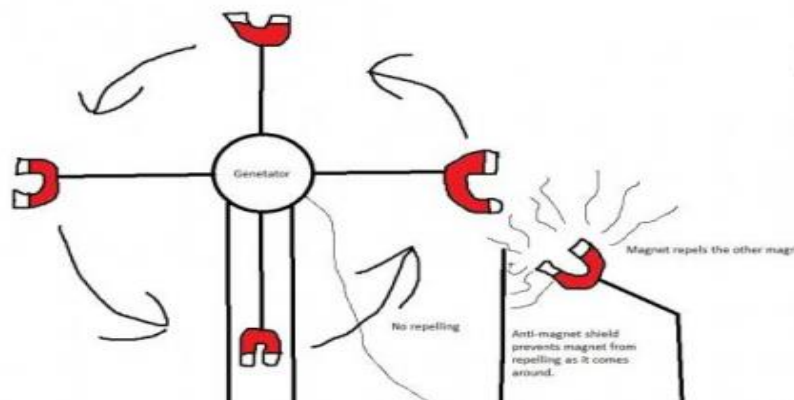


**Figure 11: Magnetic Attraction Characteristic**



**Figure 12: Magnetic Repulsion Characteristic**

Permanent magnets constructed of the metal Neodymium-Iron-Born (Nd-Fe-B) were used in this experiment to produce magnetic repulsion. The magnets were arranged such that their comparable polarities faced one another. Using the mechanical energy produced by the magnetic attraction and transforming the mechanical energy of the wind into the necessary type of mechanical power.



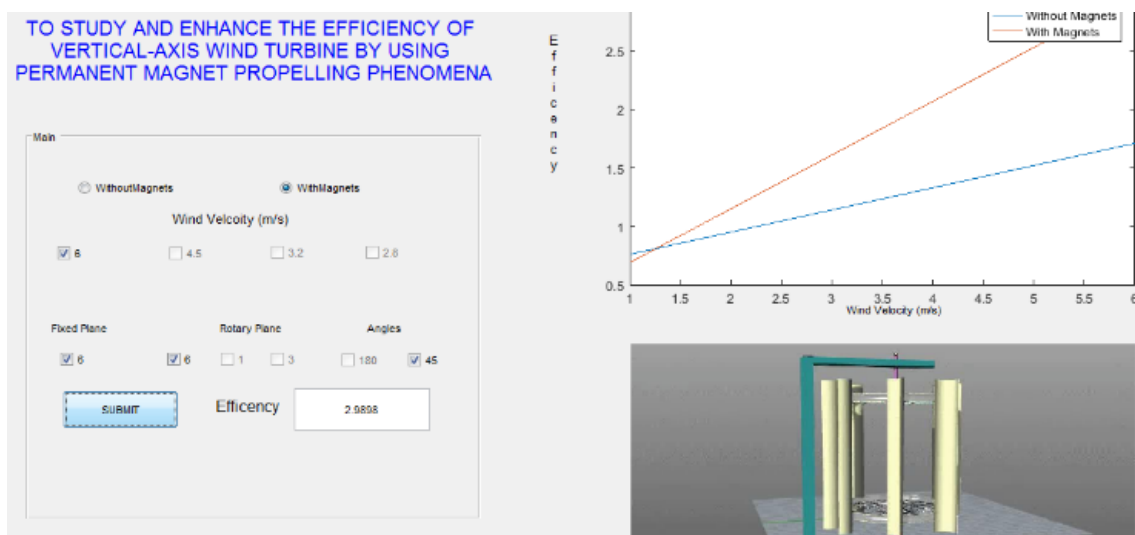
**Figure 10: While converting wind energy into mechanical energy, the Magnetic Repulsion can move in a linear or circular fashion.**

CONVENTIONAL VERTICAL AXIS WIND TURBINE SYSTEM  
PERFORMANCE AND EFFICIENCY IMPROVEMENT THROUGH  
TUBINE MODIFICATION TO INCOPERATE THE PERMANENT MAGNET PROPELLINPHENOMENON

The repellent properties of magnets were contained throughout this study's attempt to include more kinetic energy in order to accomplish higher rotational structure potency [8]. Magnetic repulsion might also be sensed easily by squeezing this repellent feature in between the mounts and rotary planes. In contrast, VAWT converts the mechanical energy from wind into the necessary reasonably mechanical power, whilst the force provided by the permanent magnet can add some type of an acceptable kinetic power.

#### IV. VALIDATION PART OF PM-VAWT

MathWorks developed MATLAB, a multi-paradigm proprietary programming language and numerical computing environment (short for "MATrix LABoratory"). With MATLAB, you may work with matrices, visualize data and functions, apply algorithms, create user interfaces, and interact with other programming languages. Although MATLAB is primarily intended for numeric calculation, an optional toolbox uses the MuPAD symbolic engine to give access to symbolic computing features. Simulink is a standalone application that improves multi-domain graphical simulation and model-based design for dynamic and embedded systems. The Mathwork Team developed a programme called MATLAB along with add-on features like Simulation and Linking. Users of this application may utilise a graphical computer programme to model, simulate, and analyses a system in a highly dynamic environment. By selecting an option from the drop-down menu, the user may create a multi-domain dynamic system that is then planned and evaluated on graphs using the array and matrix operations of a modified library block. This is frequently the reason why we choose for the MATLAB App models [5].



**Figure 11: MATLAB for Validation work**

#### V. EXPERIMENTAL METHOD

The sweptwing front cross section area of turbine constructions, which is perpendicular to air density, air flow, and wind speed, can all be proportional to the overall power of wind flow in this situation [8]. It is also possible to write as follows:

$$P_w = x = \frac{1}{2} \rho A V^3$$

CONVENTIONAL VERTICAL AXIS WIND TURBINE SYSTEM  
PERFORMANCE AND EFFICIENCY IMPROVEMENT THROUGH  
TUBINE MODIFICATION TO INCOPERATE THE PERMANENT MAGNET PROPELLINPHENOMENON

$P_w$  = Total Power in Wind ( $W/m^2$ )

$A$  = Rotary Turbine sweptwing area perpendicular to the air flow ( $m^2$ ) = 0.173 $m^2$ .

$\rho$  = Density of air for given condition ( $kg/m^3$ )

$V$  = Wind Speed Condition ( $m/sec$ )

**Table 2: Power available in Wind at Various Wind Speed Conditions is calculated Theoretically**

Sl. No	V= Avg. Wind Speed in m/sec	$P_w = x = \frac{1}{2}\rho AV^3$ W/m <sup>2</sup>
1.	6.0	22.54
2.	4.50	9.52
3.	3.20	3.4
4.	2.80	2.28

Mechanical Power ( $P_T$ ) is obtained from the rotary turbine system, is nothing but the operate of the tangentials forces ( $F$ ) & rotary turbine movement speeds in rotation per minute (RPM) provide by  $N_r$  of the rotary shaft.

$$P_T = \frac{1}{60} 2\pi N_r F$$

Force ( $F$ ) = Angular Acceleration X rotary Turbine Mass.

$N_r$  = Revolution/minutes of The Rotary Turbine

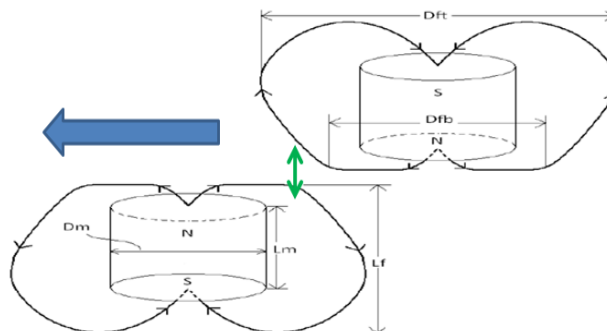
Angular Acceleration = (acceleration / radius of the turbine) revolution / $m^2$

Total mass of the Turbine = 3.12 kg

Mechanical output powers  $P_T$  is divided by the highest volume of total kinetic energy felt by the area of a particular wind turbine can be represented as power coefficient  $C_P$ ,

$$C_P = \frac{P_T}{P_W}$$

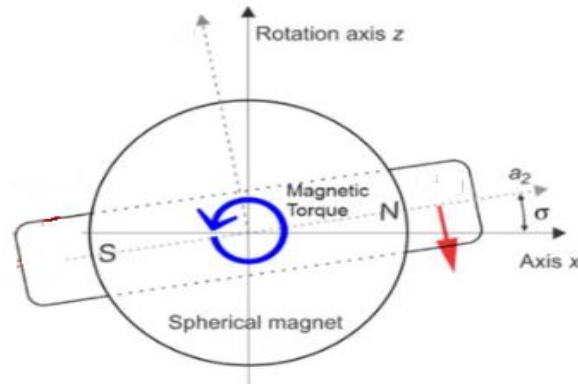
When magnets were positioned at a 180-degree or parallel angle to one another on both the rotary and fixed planes as shown in Figure 11, a little blockage to the turbine's spinning was noticed. The magnetic field produced by the permanent magnet will resist similar polarity magnets when they are placed parallel to one another and will hinder the spinning of the turbine as a result.



**Figure 12: There were two magnets parallel to one another**

CONVENTIONAL VERTICAL AXIS WIND TURBINE SYSTEM  
PERFORMANCE AND EFFICIENCY IMPROVEMENT THROUGH  
TURBINE MODIFICATION TO INCOPERATE THE PERMANENT MAGNET PROPELLINPHENOMENON

The challenge was to reduce the magnetic repulsion that adds some sort of resistance when rotary plane magnets coincide with fixed plane magnets while rotating. Magnetic repulsion of permanent magnets adds some sort of kinetic energy to the turbine while transforming the kinetic energies available in the wind into mechanical energy.



**Figure 13: Magnets orientation Visualization Top view.**

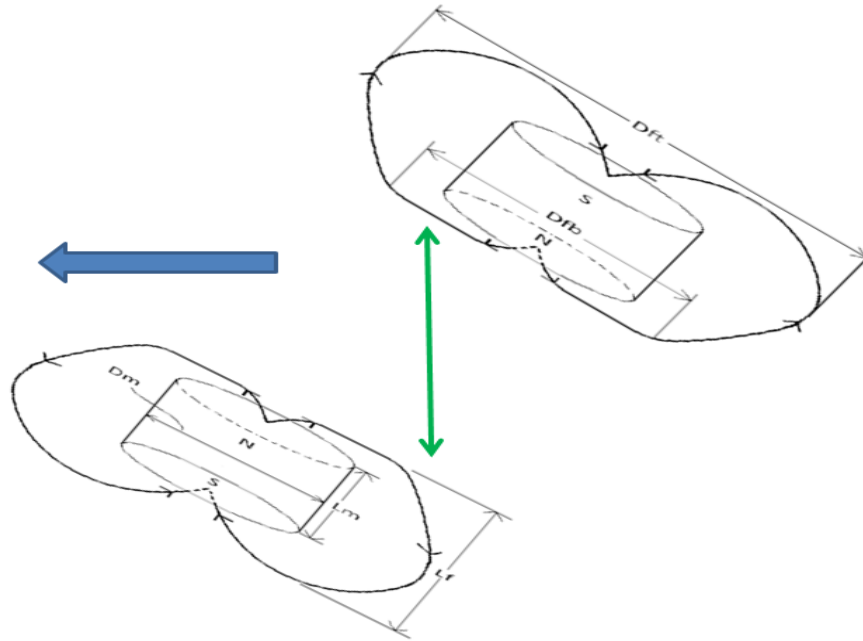
By rotating the magnets' installation orientation to 45 degrees, as shown in Figures 14 and 25, the resistive repulsive force was lowered. Therefore, the resistive force produced by magnets when they coincided was lower than the repulsive force produced when they separated from the magnetic field. As a result of adding these repulsive forces, wind kinetic energy is converted into the necessary type of mechanical energy.

The goal of the tests was to determine the best positioning and orientation for magnet sets under different wind speed conditions.

**Table 3: The optimal orientation and position for magnet installation in a PM-Propelled VAWT under varied win speed circumstances to obtain greater kinetic energy and smother operation were determined through experimentation.**

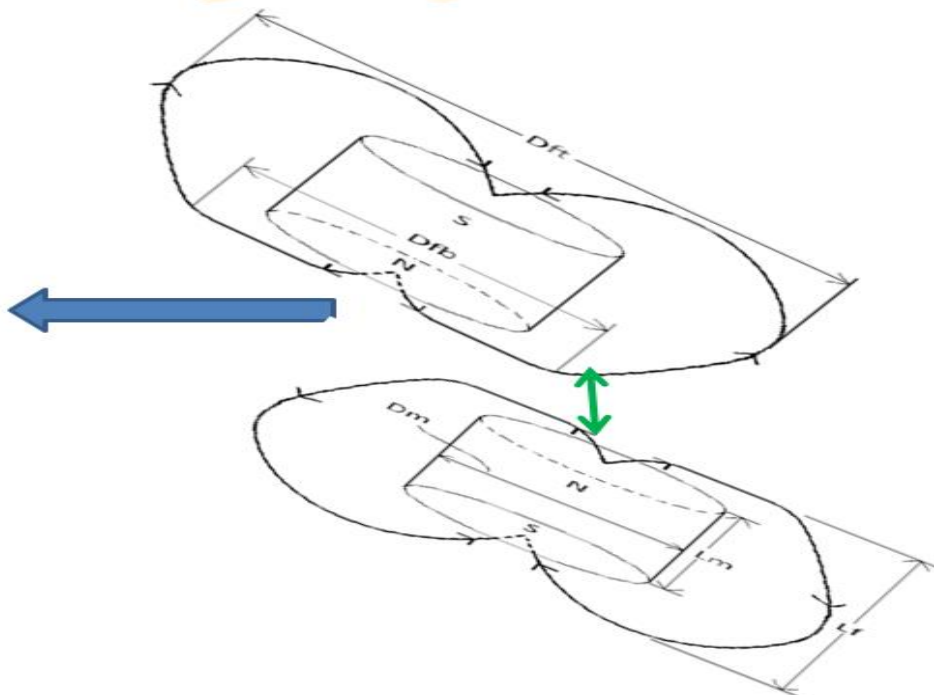
S. No	Orientation of Magnets Placement	Wind Speed in m/s	Turbine RPM	$P_T = \frac{1}{60} 2\pi N_r F$	$C_P = P_T/PW$
<b>Conventional-VAWT</b>					
1.	Conventional Turbine Without Magnets	6	88.00	385.24	<b>17.08</b>
2.		4.5	76.00	137.00	<b>14.40</b>
3.		3.2	72.00	37.08	<b>10.84</b>
4.		2.8	68.00	17.51	<b>7.64</b>
<b>Permanent Magnet-Propelled VAWT</b>					
1.	Six magnets were placed 180 degrees apart from one another or parallel to one another.	6	87.00	425.67	<b>18.88</b>
2.		4.5	79.00	162.75	<b>17.11</b>
3.		3.2	70.00	36.05	<b>10.54</b>
4.		2.8	61.00	15.71	<b>6.85</b>
5.	Six permanent magnets are inserted into the fixed component, and one magnet is oriented 180 degrees on the spinning portion.	6	89.00	389.62	<b>17.28</b>
6.		4.5	78.00	140.60	<b>14.78</b>
7.		3.2	71.00	36.57	<b>10.69</b>
8.		2.8	66.00	17.00	<b>7.42</b>
9.	6 PM were mounted on stationary section & 3 magnets were positioned in the spinning component with a 180° orientation.	6	92.00	426.44	<b>18.91</b>
10.		4.5	76.00	137.00	<b>14.40</b>
11.		3.2	70.00	18.03	<b>5.27</b>
12.		2.8	43.00	11.07	<b>4.83</b>
13.	Six magnets were inserted on the stationary component in a 180° orientation, and one was positioned in the rotating segment at a 45° angle.	6	90.00	394.00	<b>17.47</b>
14.		4.5	82.00	147.81	<b>15.54</b>
15.		3.2	71.00	36.57	<b>10.69</b>
16.		2.8	65.00	16.74	<b>7.30</b>
17.	Both the spinning component's three permanent magnets and the stationary part's six were put at a 45° angle.	6	91.00	398.37	<b>17.67</b>
18.		4.5	78.00	160.69	<b>16.89</b>
19.		3.2	73.00	37.60	<b>10.99</b>
20.		2.8	70.00	18.03	<b>7.87</b>
21.	A 45-degree angle was made between the placement of three permanent magnets and six permanent magnets in the spinning component.	6	94.00	435.71	<b>19.32</b>
22.		4.5	85.00	175.11	<b>18.41</b>
23.		3.2	73.00	56.40	<b>16.49</b>
24.		2.8	64.00	32.96	<b>14.38</b>
25.	The six magnet sets were angled at 45 degrees.	6	102.00	551.59	<b>24.46</b>
26.		4.5	82.00	211.16	<b>22.20</b>
27.		3.2	78.00	60.26	<b>17.61</b>
28.		2.8	71.00	36.57	<b>15.96</b>

CONVENTIONAL VERTICAL AXIS WIND TURBINE SYSTEM  
PERFORMANCE AND EFFICIENCY IMPROVEMENT THROUGH  
TURBINE MODIFICATION TO INCOPERATE THE PERMANENT MAGNET PROPELLINPHENOMENON



**Figure 12: The turbine will encounter less of the resistive force produced by magnetic repulsion.**

Figure 12 serves as an example. Due to the 45 degree orientation, which increased the distance between the magnetic flux density produced by magnets of the same polarity when they were coincident, the restive force created by magnetic repulsive force will be reduced.

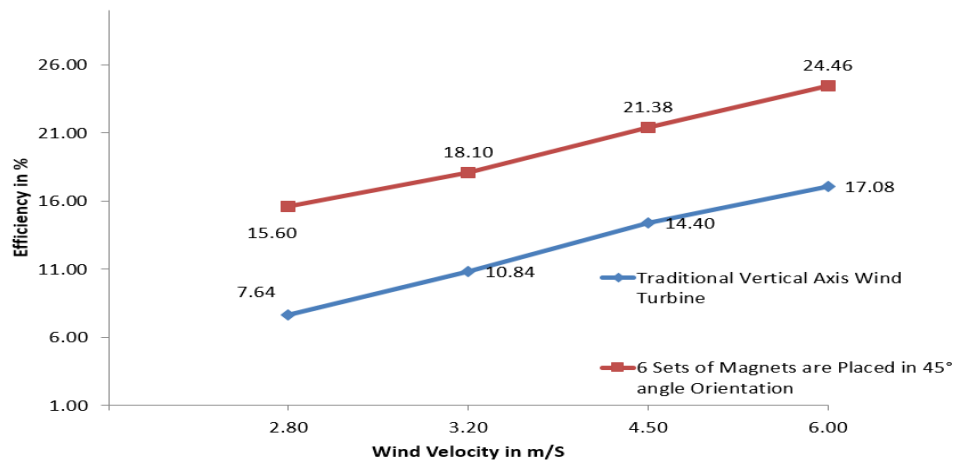


**Figure 13: A kind of K.E will be applied to the turbine by the resistive force caused by magnetic repulsion.**



CONVENTIONAL VERTICAL AXIS WIND TURBINE SYSTEM  
PERFORMANCE AND EFFICIENCY IMPROVEMENT THROUGH  
TUBINE MODIFICATION TO INCOPERATE THE PERMANENT MAGNET PROPELLINPHENOMENON

Figure 13 shows that there will be a stronger restive force created by the magnetic repulsive force because the magnetic flux density produced by the same polarity magnets exiting the field will be less separated owing to the 45 degree orientation. As a result, the mechanical energy from the wind will be converted into kinetic energy, which will also be added to the wind turbine.



**Graph 1: Graph comparing the effectiveness of PM-propelled VAWT vs conventional VAWT**

In this investigation, it was found that the PM-driven VAWT had a greater rotation speed than our conventional VAWT. Although the traditional VAWT only achieved 17.08 percent efficiency, the Permanent magnet powered VAWT obtained an efficiency of 24.4 percent for the same wind speed scenario.

## VI. FINDINGS AND DISCUSSION

Despite the fact that local average wind speeds vary widely, most places in the world have a significant amount of wind energy deployment potential. In reality, the technical potential for wind energy exceeds the total amount of power produced globally. Strong winds may be found in many places across the world, but remote sites are frequently the best for harnessing wind power. Wind energy may be able to satisfy our energy demands. It has a lot of promise and is easy to use. As long as you build the turbine, everything else will be delivered without charge. After analyzing the data, we came to the conclusion that magnetic properties, notably their ability to repel and attract, were utilized as power banks. In this instance, the force generated by the magnets of opposing polarity was used to further activate the turbine and transform the wind's kinetic energy into the necessary kind of mechanical power. Wind energy is the kinetic energy that these winds produced. There hasn't been much research done with hybrid power technology, other from the synchronization of solar and wind power. So, using the magnetic propulsive phenomenon as a source of energy, research and development were done to construct a permanent magnet-driven vertical axis wind turbine.

In this scenario, the force produced by the permanent magnets can provide the rotary blade structure with some sort of dynamic power while transforming alternative energy into the necessary kind of mechanical power [8]. The shaft rotational speed of the static magnet

CONVENTIONAL VERTICAL AXIS WIND TURBINE SYSTEM  
PERFORMANCE AND EFFICIENCY IMPROVEMENT THROUGH  
TUBINE MODIFICATION TO INCOPERATE THE PERMANENT MAGNET PROPELLINPHENOMENON

propelled-turbine VAWT was found to be higher in this performance evaluation when compared to our conventional VAWT. Conventional VAWTs had an efficiency of around 17.081 percent, whereas the static magnet driven VAWT has an efficiency of 24.466 percent for the same wind speed situation. Additionally, potency was said to have improved in conditions with slower wind speeds. As a result, when static magnet dynamical features are used, it will also perform more effectively when there is less wind. For the aforementioned reasons, we think that PM Propelled Wind Turbine is significantly more efficient than the hybrid idea of solar energy and wind energy.

## VII. CONCLUSIONS

Natural resources that replenish more quickly than they are exhausted are the source of renewable energy. Two examples of such cyclically renewing sources are the sun and the wind. There are many different renewable energy options available to us. Contrarily, it takes hundreds of millions of years for non-renewable fossil fuels like coal, oil, and gas to form. When fossil fuels are burnt to create energy, dangerous greenhouse gases like carbon dioxide are generated. There is no question that in order to keep up with the current expansion in human living standards, the world's electricity supply will need to be significantly increased in the near future. At the same time, we are aware of the fundamental fact that wind is produced as a result of the earth's rotation and uneven heating, which results in temperature changes between day and night. Heated atmospheric air will rise near the equator and progressively spread toward the poles of the globe, producing wind, depending on the molecule's temperature. It seems obvious that employing wind power as a long-term solution to the current global energy issues may be feasible. However, the needs for sustainability have been evaluated. Because of this, even if the resource is valuable enough to support a variety of economic operations in its current technological state, the fulfilment of enormous technological potential might ultimately lead to the resource becoming infinite. Wind energy is the kinetic energy that these winds produced. There hasn't been much research done with hybrid power technology, other from the synchronization of solar and wind power.

So, using the magnetic propulsive phenomenon as a source of energy, research and development were done to construct a permanent magnet-driven vertical axis wind turbine. Due to climate change and global warming, which contribute to the production of additional kinetic energy in the form of wind, the supply of wind energy will not be restricted in the future. Additionally, by including the fundamental properties of magnets, such as their attractive and repulsive forces, the world's energy requirements with this hybrid energy notion of wind energy already seem implausible. Even in conditions of low wind speed, our turbine's efficiency was improved by the magnetic repulsion feature. Consequently, there is an opportunity to provide.

## REFERENCES

- [1] Sevvel P, Santhosh P "Innovative Multi Directional Wind Turbine" International Journal of Innovative Research in Science, Engineering and Technology Volume 3, Special Issue 3, March 2014 page no 1237 to 1240
- [2] Gary L. Johnson "Wind Energy Systems", Electronic Edition Manhattan, October 10, 2006, pp. 61-70-15

- [3] Er. Girt, K. M. Krishnan, G. Thomas, E. Girt, Z. Altounian, Coercivity limits and mechanism in nanocomposite Nd-Fe-B alloys, *Journal of Magnetism and Magnetic Materials*, 231 (2001) 219 – 230
- [4] Robert W Whittlesey<sup>1</sup>, Sebastian Liska<sup>1</sup> and John O Dabiri “Fish schooling as a basis for vertical axis wind turbine farm design” California Institute of Technology, Pasadena CA 91125, USA February 11, 2010 Page 1-10
- [5] Pradeep Bhatta, Michael A. Paluszek and Joseph B. Mueller “Individual Blade Pitch and Camber Control for Vertical Axis Wind Turbines” Princeton Satellite Systems, Inc., 33 Witherspoon Street, Princeton, NJ 08542, USA
- [6] J. P. Hennessey, Jr., “Some aspects of wind power statistics, and performance analysis of a 6MW wind turbine-generator”. *J. Appl. Meteorol.*, vol. 16, no. 2, pp. 119–28, Feb. 1997.
- [7] Gary L. Johnson “Wind Energy Systems”, Electronic Edition Manhattan, October 10, 2006, pp. 61-70-157
- [8] Er. Girt, K. M. Krishnan, G. Thomas, E. Girt, Z. Altounian, Coercivity limits and mechanism in nanocomposite Nd-Fe-B alloys, *Journal of Magnetism and Magnetic Materials*, 231 (2001) 219 – 230
- [9] A.D. Wright and L.J. Fingersh, *Advanced Control Design for Wind Turbines: Part I, Design, Implementation, and Initial Tests*. NREL /TP-500-42437, Golden, CO, National Renewable Energy Laboratory (2008).
- [10] Sevel P, Santhosh P “Innovative Multi Directional Wind Turbine” *International Journal of Innovative Research in Science, Engineering and Technology* Volume 3, Special Issue 3, March 2014 page no 1237 to 1240
- [11] Castillo, Javier “Small-Scale Vertical Axis Wind Turbine Design” Bachelor’s Thesis Tampere University of Applied Sciences December 2011
- [12] N. Vaughn, “Renewable Energy & the Environment”, CRC Press, Ed. 2009 pp 63 -101
- [13] J. J. Miao<sup>1,a</sup>, S. Y. Liang<sup>2</sup>, R. M. Yu<sup>3</sup>, C. C. Hu<sup>4</sup>, T. S. Leu<sup>5</sup>, J.C. Cheng<sup>6</sup> and S. J. Chen<sup>7</sup> “Variable Pitch Control Strategy” *Applied Mechanics and Materials* Vol. 225 (2012) Page No. 338-343
- [14] In Seong Hwang, Seung Yong Min, In Oh Jeong, Yun Han Lee and Seung Jo Kim “Efficiency Improvement of a New Vertical Axis Wind Turbine by Individual Active Control of Blade Motion” School of Mechanical & Aerospace Engineering, Seoul National University San 56-1, Sillim-dong Korea Page No 23-56]
- [15] N. Talijan, J. Staji-Tros, T. Zak, V. Menushenkov, A. Milutinovi- Nikoli, Nd-Fe-B Alloys Synthesis-Structure-Properties, *Proc. European Congress & Exhibition on Powder Metallurgy PM 2001, Nice, France, 2 (2001) 280-284*
- [16] Gary L. Johnson “Wind Energy Systems”, Electronic Edition Manhattan, October 10, 2006, pp. 61-70-157
- [17] Pallabazzer R. “Parametric analysis of wind siting efficiency”, *J. Wind Eng Ind Aerodyn* 2003; 91:1329-1352.
- [18] Ramachandra T.V, Ganesh Hegde, Gautham Krishnadas Potential Assessment And Decentralized “Applications Of Wind Energy In Uttara Kannada, Karnataka *International Journal Of Renewable Energy Research*” Vol.4, No.1, 2014 Page 1-10