

SHAPE OPTIMIZATION OF A HEAVYDUTY TRUCK CHASSIS FRAME USING CAE TOOLS

Abstract

Weight plays a crucial role in automobile engines, significantly influencing riding qualities and travel cost. The chassis frame provides about twenty percent of the truck's curb weight, making it a vital component in automobiles. Serving as the backbone of heavy vehicles, the chassis bears the maximum load for all operating conditions while providing a sturdy platform to connect the front and rear suspensions with minimal deflection. Consequently, both weight and strength are key parameters in chassis design. Extensive analysis of various research studies reveals opportunities for optimizing various parameters such as mass, stress-strain values, and deformations by adjusting the cross-sections of the chassis. Present work focuses on modeling, structural analysis, and heavy weight vehicle chassis optimization, considering the constraints like maximum stress and deformations at real maximum load.

To conduct the study, we utilized the dimensions and material of the TATA 2518TC chassis frame for structural analysis. We considered three different cross-sections—C, I, and Hollow Rectangular (Box) types—using structural steel ST37 due to its known properties and availability. Next, we subjected these cross-sections to identical conditions and developed three-dimensional solid models using CAE software. Performing the analysis in ANSYS Workbench, we validated the results by employing analytical calculations involving shear force, bending moment diagrams, and stress distribution. Furthermore, standard optimization techniques are employed in Design Explorer, and Design of Experiments is used to perform several

Authors

P. Ravindra Kumar

Department of Mechanical Engineering
Lakireddy Bali Reddy College of
Engineering (Autonomous) Mylavaram
Vijayawada, Andhra Pradesh, India
pasupuletirk@lbrce.ac.in

CH. Srinu

Department of Mechanical Engineering
Lakireddy Bali Reddy College of
Engineering (Autonomous) Mylavaram
Vijayawada, Andhra Pradesh, India
srinuchirasani6@gmail.com

SHAPE OPTIMIZATION OF A HEAVYDUTY TRUCK CHASSIS FRAME USING CAE TOOLS

samplings on the three cross sections. The optimization process aims to achieve mass reduction while maintaining stress and deformation constraints and varying thickness variables. The findings indicate that the Channel section proves to be the most suitable among the tested cross sections, boasting a high strength-to-weight ratio. It results in a remarkable 31% reduction in weight when compared to the existing TATA 2518TC chassis frame. This insight could lead to improved performance and efficiency in heavy vehicles.

Keywords: Heavy truck chassis frame, ANSYS, FEM, Computer Aided Engineering (CAE) C, I, and Hollow (Box type) sections, vehicle weight, stress, and deformation.

I. INTRODUCTION

Today's in vehicle industry, a significant challenge lies in meeting the growing demands for enhanced performance, reduced weight, and extended component life, all while keeping costs reasonable and development time short. Among the crucial components in vehicles, the chassis of trucks plays a central role as it integrates various truck systems, including axles, suspension, powertrain, cab, and trailer. Due to its importance, the truck chassis frame is frequently targeted for improvement and refinement. It finds application in various industrial sectors, for example in logistics supply, agriculture sectors, factories, and other transportation industries.

The Finite Element Method (FEM) is used to perform stress analysis on the chassis frame, which consists of side members connected with a series of cross members. This analysis identifies critical points with the highest stress levels to ensure the chassis' reliability. These critical points play a crucial role in contributing to potential fatigue failure. By determining the magnitude of stress, we can predict the life span of the truck chassis frame, enabling engineers to make informed design decisions to meet the desired performance and longevity requirements. The Indian truck manufacturing industry produces a wide range of trucks tailored for diverse applications. These trucks can be categorized based on their gross vehicle weight (GVW). Medium commercial vehicles fall within the 3.5 to 16-ton GVW range, while heavy commercial vehicles exceed 16 tons. On the other hand, light commercial vehicles have a GVW of less than 3.5 tons. In India, haulage trucks serve as heavy-duty carriers, mainly exploited for transporting parcels, courier services, and in supplying logistics. Few are specialized for transporting cars, two and three-wheelers, as well as carrying coal, bricks, sand, or serving as water and petrol tankers. Heavy loaded trucks are robust and find applications in acid tankers, containers transit mixers, recovery trucks, self-loading cranes, and even as LPG containers. Tippers, known for their durability, are used in industries like construction, mining, quarrying, and public services for tipping operations. Dumpers play a vital role in handling waste and other materials and can be utilized for both on- and off-highway needs. They are commonly employed by municipal corporations and the construction industry. Cabs are available in various models, including pick-up cabs, serving as utility vehicles, with seating capacities ranging from six to ten passengers. Tractor trucks and distributed vans are extensively used in India to transport goods efficiently.

II. CHASSIS FRAMES CLASSIFICATION

1. Chassis Frame ladder type (Body on Frame)
2. Tubular Space Frame
3. Monocoque Chassis frame
4. Ulsab Monocoque Chassis frame
5. Backbone Chassis frame



Figure 1: Chassis Frame -Ladder Type

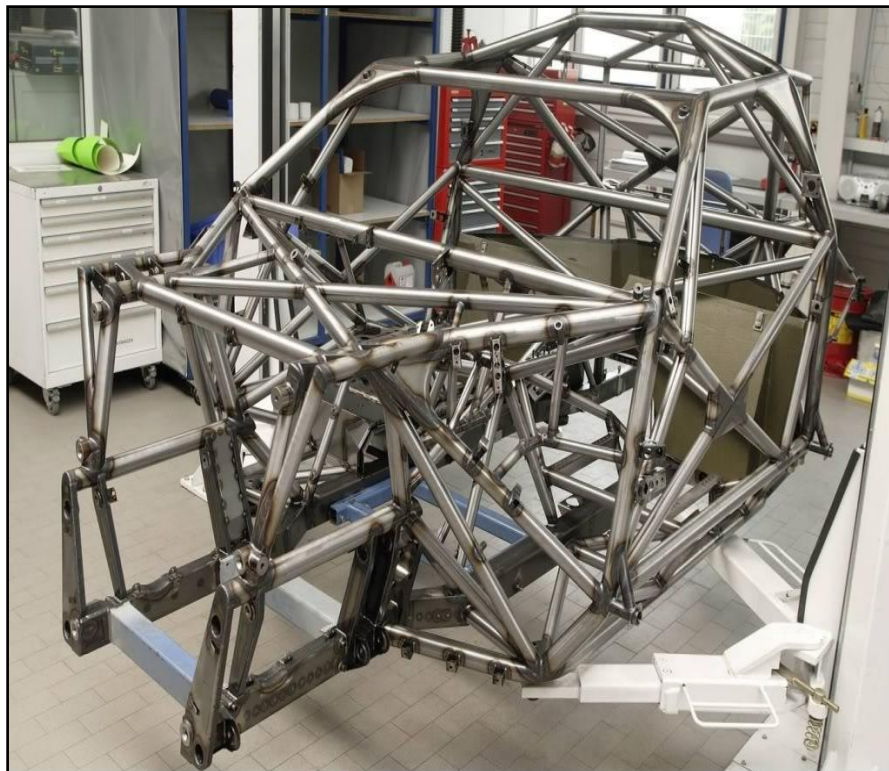

Figure 2: Tubular Chassisframe



Figure 3: Monocoque Chassisframe



Figure 4: Back bone Chassis Frame

Optimization techniques are integral to the structural design process, aiming to derive the most advantageous solutions while utilizing available resources efficiently. In engineering, various decisions must be made during the design, construction, and maintenance stages. These decisions aim to minimize efforts or maximize desired benefits, which can be expressed as functions of specific variables. Optimization encompasses the task of discovering conditions that lead to either the maximum or minimum value of these functions. To find the minimum of functions involving multiple variables under specific constraints, mathematical programming techniques prove to be highly valuable. Stochastic process techniques aid in analyzing problems in statistical methods, utilizing random variables, and known probability distributions, aid in analyzing experimental data and

constructing empirical models, Thus, it offers the most precise depiction of the physical situation... All the above techniques collectively contribute to enhancing decision-making and optimizing engineering systems for maximum efficiency and benefit.

III. LITERATURE REVIEW

Optimization of a heavy-duty truck chassis frame using ANSYS involves utilizing advanced computational methods to refine and enhance the design of the chassis frame for improved performance and efficiency. ANSYS is a powerful computer-aided engineering (CAE) software that allows engineers to perform FEA analysis and structural simulations to evaluate the behavior and performance of complex mechanical systems. Shape optimization using ANSYS allows engineers to explore a vast design space, enabling the creation of lightweight yet robust chassis frames that meet the demanding requirements of heavy-duty trucks. By efficiently distributing materials and refining the shape, this process leads to improved fuel efficiency, reduced emissions, and enhanced overall performance of heavy-duty trucks.

A. Agarwal and L. Mthembu in 2022, [1] focused on a ladder-type Heavy Motor Vehicle (HMV) chassis, where a combination of Static Structure Analysis and Optimization is employed. The objective of the study is to investigate the possibility of utilizing Metal Matrix Composite (MMC) material, particularly Unidirectional Aluminium P100/6061 Al MMC, to achieve mass reduction in the HMV chassis. For this purpose, Finite Element (FE) analysis is conducted using ANSYS 18.1 software, which incorporates a sparse grid initialization optimization scheme based on the response surface method. The initial chassis, made of conventional material (St52E), weighs 214.64 Kg. By implementing the Metal Matrix Composite P100/6061 Al material, the chassis' mass is significantly reduced to 67.922 Kg, representing a remarkable decrease of approximately 68.4% through the sparse grid initialization optimization process. This study demonstrates the remarkable potential of using metal matrix composites in HMV chassis design to achieve substantial weight reduction. The application of MMC materials in the chassis construction opens up promising avenues for enhancing vehicle performance, fuel efficiency, and overall cost-effectiveness, making it an area of interest in the automotive industry.

S. Nandhakumar et., al. in 2021, [2] To ensure the new design meets safety standards, a thorough structural analysis is conducted on the proposed chassis frame model using ANSYS 20.0 simulation software. The analysis takes into account stress and deformation as critical design constraints, ensuring that the modified frame maintains structural integrity and withstands real-world operating conditions.

Hongshen Zhang et al., in 2020, [3] done numerical analysis, the frame structure was subjected to optimization. The results of the optimization were promising, indicating significant improvements in various stress factors. Specifically, the optimized frame exhibited a remarkable reduction of 44.499% in bending stress under full-load braking conditions, a 23.364% decrease in stress during full-load torsional operating conditions, and a 31.303% decrease in stress overall. Moreover, the optimization led to enhanced stiffness properties of the frame. The bending stiffness experienced a notable increase of 4.026%, while both the front and rear torsional stiffnesses exhibited improvements, with increments of 4.442% and 4.092%, respectively. These findings demonstrate the effectiveness of the numerical analysis-driven optimization in improving the frame structure's performance and

stress distribution, as well as enhancing its overall stiffness characteristics. The optimized design holds significant promise for enhancing the vehicle's performance and ensuring its robustness under various operational conditions.

ShuvodeepDe,et.,al. in 2019, [4] done work on entirely automated process was developed to generate a FEM model of a large commercial truck chassis frame, enabling weight optimization while considering multiple load cases and constraints. This process involves optimizing various parts of the chassis through shape and size adjustments. The chassis consists of various components, each of which can undergo optimization using shape and size optimization techniques. Specifically, the shape of the side rail is represented by 17 variables, while an additional 15 design variables define the thicknesses of webs and flanges at different sections of the side rails. The optimization problem considers five distinct load conditions, corresponding to various road events. Constraints are applied to restrict the allowable maximum Von mises stress and the first vertical bending, ensuring that the chassis adheres to safety and performance standards. To achieve this optimization, the Particle Swarm Optimization algorithm is implemented, leveraging parallel processing to enhance computational efficiency. The final outcome demonstrates a significant mass reduction of approximately 13.25% compared to the baseline model, resulting in a lighter and more efficient truck chassis.

T. Nikhil and D. H. Burande in 2017, [5] In this study, the focus was on analyzing the ladder type chassis frame of the Eicher E2 model using ANSYS 16 Software. The analysis involved a combination of theoretical and numerical approaches, utilizing the fundamental principles of strength of materials. Through rigorous analysis, it was observed that the rectangular box section of the chassis exhibited superior strength when compared to the C cross section. Furthermore, the rectangular box section demonstrated low deflection, along with the lowest stress and deformation values among the different cross-sections studied. These findings highlight the significance of choosing the appropriate cross-section for the chassis frame design, as it directly impacts the structural integrity and performance of the vehicle. The preference for the rectangular box section due to its added strength and reduced deformation can contribute to the development of safer and more reliable vehicles.

S.N. Vijayan, et., al. in 2015, [6] The primary objective of this research is to optimize the design of a chassis by employing the Box-Behnken design scheme, focusing on two tested materials: P100/6061 Al and Al GA 7-230 MMC. Through the implementation of the design of experiments, various design points were generated for evaluation. For each design point, equivalent stress, deformation, and mass were thoroughly assessed. The variable selected for optimization was the cross-member width, which played a crucial role in determining the chassis performance and characteristics. Using the ANSYS software, CAD modeling and FE simulation were conducted for the heavy motor vehicle chassis. The optimization process led to the generation of response surface plots representing equivalent stress, deformation, and mass. These plots effectively illustrated the range of dimensions where these parameters reached their maximum or minimum values, providing valuable insights for refining the chassis design. By leveraging the Box-Behnken design scheme and FE analysis with ANSYS software, this research successfully optimized the chassis design and gained a comprehensive understanding of the materials' performance. This knowledge is essential for producing highly efficient and reliable heavy motor vehicle chassis, contributing to improved overall vehicle performance and safety.

Stalin, B.et., al in 2016, [7] used Utilizing CREO 2.0 modelling software, the front-end crossbar of a TATA407 vehicle frame was designed, and subsequent analysis was performed using Ansys Workbench 14.5. A comparison was made between the stress distribution and deflection results of two different crossbars: one made of conventional steel and the other using CFRP (Carbon Fiber Reinforced Polymer).The evaluation revealed that the CFRP crossbar exhibited superior performance, showcasing an improved strength-to-weight ratio compared to the conventional steel crossbar. This enhancement signifies that the utilization of CFRP material offers significant advantages, making it a promising choice for the front-end crossbars in vehicle frames.

S.Prabakaran and K.Gunasekarin 2014, [8] presented the efforts made to enhance the automotive chassis by optimizing it while considering constraints such as equivalent stress, maximum shear stress, and deflection under the maximum load condition. To achieve this, finite element techniques were employed for the analysis of the structural system, specifically the chassis. To begin, a comprehensive sensitivity analysis was conducted to identify opportunities for weight reduction. Subsequently, a precise finite element model of the chassis was developed using SOLIDWORKS. With the model ready, finite element analysis (FEA) was performed using the ANSYS Workbench software. By utilizing this approach, the study aimed to identify areas where the chassis could be strengthened or modified to ensure optimal performance under various stress and load conditions. The optimization process is vital for enhancing the overall efficiency, safety, and reliability of the automotive chassis.

Alireza Arab Solghar and Zeinab Arsalanloo in 2013, [9] conducted a comprehensive study on the chassis of the Hyundai Cruz Minibus. The analysis involved utilizing ABAQUS Software for modeling and simulation. For the static analysis, the weight of the chassis was considered as the main load. On the other hand, for dynamic analysis, three important scenarios were considered: Acceleration, Braking, and Road Roughness. The results of the dynamic analysis revealed an interesting observation: the stresses on the chassis frame caused by brakeis notably higher in comparison to those induced by acceleration. This finding highlights the significance of considering braking forces in chassis design and optimization, as they can significantly impact the structural integrity and performance of the Hyundai Cruz Minibus.

V Patel et., al. in 2012, [10] delves into the optimization of design and structural analysis of an automotive chassis frame to achieve weight reduction. The study aims to enhance the performance and efficiency of the automotive chassis by employing advanced structural analysis techniques and design modifications.

Kutay Yilmazcoban and Yasar Kahraman in 2011, [11] conducted a study focused on the FEM technique employed to optimize the thickness of a middle tonnage truck chassis frame. The primary aim of this research was to achieve a reduction in material usage, thereby lowering material costs. The study involved analyzing three different thicknesses of materials for the chassis and comparing the results in terms of stress and displacement. Through their analysis, the researchers found that a chassis with a 4mm thickness was deemed safe enough to carry a load of 15 tons. By identifying the optimal thickness, this study provided valuable insights into designing a more cost-efficient and reliable middle tonnage truck chassis while maintaining structural integrity and safety standards.

IV. STEPS TO DESIGN THE SHAPE OPTIMIZATION OF CHASSIS FRAME

The process of shape optimization typically follows these steps:

- 1. Problem Definition:** Engineers define the objectives and constraints of the optimization. The main goal is often to reduce weight while maintaining or improving the strength and stiffness of the chassis frame. Additional constraints may include stress limits, deflection limits, and manufacturing constraints.
- 2. Geometrical Model:** A 3D geometrical model of the existing chassis frame is created in ANSYS or imported from CAD software.
- 3. Finite Element Model:** The geometrical model is discretized into finite elements to create a detailed and accurate representation of the chassis frame. Each element corresponds to a small portion of the structure.
- 4. Material Properties:** Material properties, such as Young's modulus and Poisson's ratio, are assigned to the finite elements to define the mechanical behavior of the materials used in the chassis.
- 5. Loads and Boundary Conditions:** The model is subjected to various loads and boundary conditions that represent real-world operating conditions, such as static loads, dynamic loads, and road vibrations.
- 6. Optimization Settings:** Engineers set up the optimization parameters, including the design variables that can be modified during the optimization process. These design variables may include cross-sectional areas, thicknesses, or the shape of specific components.
- 7. Objective Functions and Constraints:** The objective functions represent the goals of optimization, such as minimizing weight, stress, or deflection. Constraints are conditions that must be satisfied during the optimization, such as limiting stress levels or maintaining a specific safety factor.
- 8. Optimization Algorithm:** ANSYS uses sophisticated optimization algorithms to iteratively modify the design variables to find the optimal solution that meets the defined objectives and constraints.
- 9. Analysis and Iteration:** ANSYS performs multiple analyses and iterations to refine the chassis frame design, progressively improving its performance according to the defined objectives.
- 10. Evaluation of Results:** Engineers analyze the results of each optimization run to determine if the objectives and constraints are satisfied. If not, they adjust the optimization settings and iterate again until an optimal design is achieved.

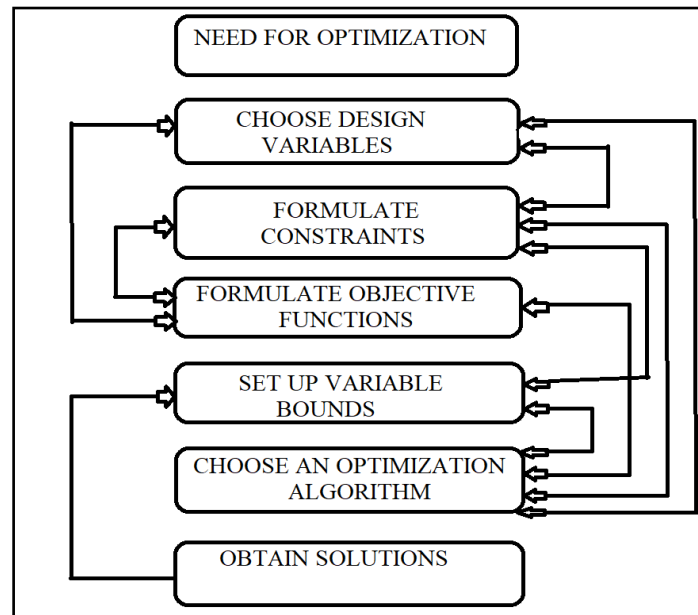

Figure 5: Flowchart of Design Procedure for Optimization

By following these steps, it can be effectively designed, simulated, and optimized its performance to ensure its desired requirements. The specifications of chassis frame are shown in table 1.

The following are the values of parameters for the chassis:

Total length of the chassis: 9010 mm
 Width of the chassis: 2440 mm
 Wheelbase: 4880 mm
 Front Overhang: 1260 mm
 Rear Overhang: 2155 mm
 Ground Clearance: 250 mm
 Capacity (GVW): 25 ton
 Kerb Weight: 5750 Kg
 Payload: 19250 Kg

V. MODELLING OF CHASSIS FRAME

NX, previously known as NX Unigraphics, is a state-of-the-art CAD/CAM/CAE software package that was initially developed by Unigraphics and later acquired by Siemens PLM Software in 2007. This comprehensive software is widely used for design, engineering analysis, and manufacturing, offering a seamless solution to deliver superior products more efficiently and rapidly. With NX, engineers and designers have access to a range of key capabilities that facilitate fast and flexible product development: Advanced tools for conceptual design, 3D modeling, and documentation, empowering users to create sophisticated designs with precision and ease.

Multi-disciplined simulation features for structural analysis, motion analysis, thermal analysis, fluid flow analysis, and multi-physics applications, enabling comprehensive

evaluation of product performance and behavior. Complete part manufacturing solutions for tooling, machining, and quality inspection, ensuring seamless integration between designs and manufacturing processes. NX software empowers users to make smarter decisions throughout the integrated product development process. By utilizing NX, companies can design, simulate, and manufacture better products at an accelerated pace, thereby gaining a competitive edge in their respective industries. NX NASTRAN, a powerful finite element (FE) solver, demonstrates exceptional proficiency in conducting stress, vibration, buckling, structural failure, heat transfer, acoustics, and aeroelasticity analyses. Renowned manufacturers and engineering suppliers across industries such as aerospace, automotive, electronics, heavy machinery, and medical devices heavily depend on NX Nastran software for their critical engineering computing needs. It empowers them to create safe, reliable, and optimized designs within ever-shorter design cycles. NX Nastran can be used as a standalone solver or seamlessly integrated into Simcenter 3D Solutions. It has been credited with significantly reducing product development costs by digitally testing performance through computer modeling, which is cheaper, faster, and more efficient compared to traditional physical prototyping processes. By adopting NX Nastran, companies can achieve increased product quality and simultaneously save on potential warranty costs. Overall, NX Nastran has revolutionized engineering analysis, offering state-of-the-art simulations that lead to enhanced product performance, improved safety, and reduced time-to-market, making it an invaluable tool for modern engineering and design practices. Stress distribution and displacement pattern of C-Sections, I-Sections and hollow sections are shown in figures 6 to figure 10.

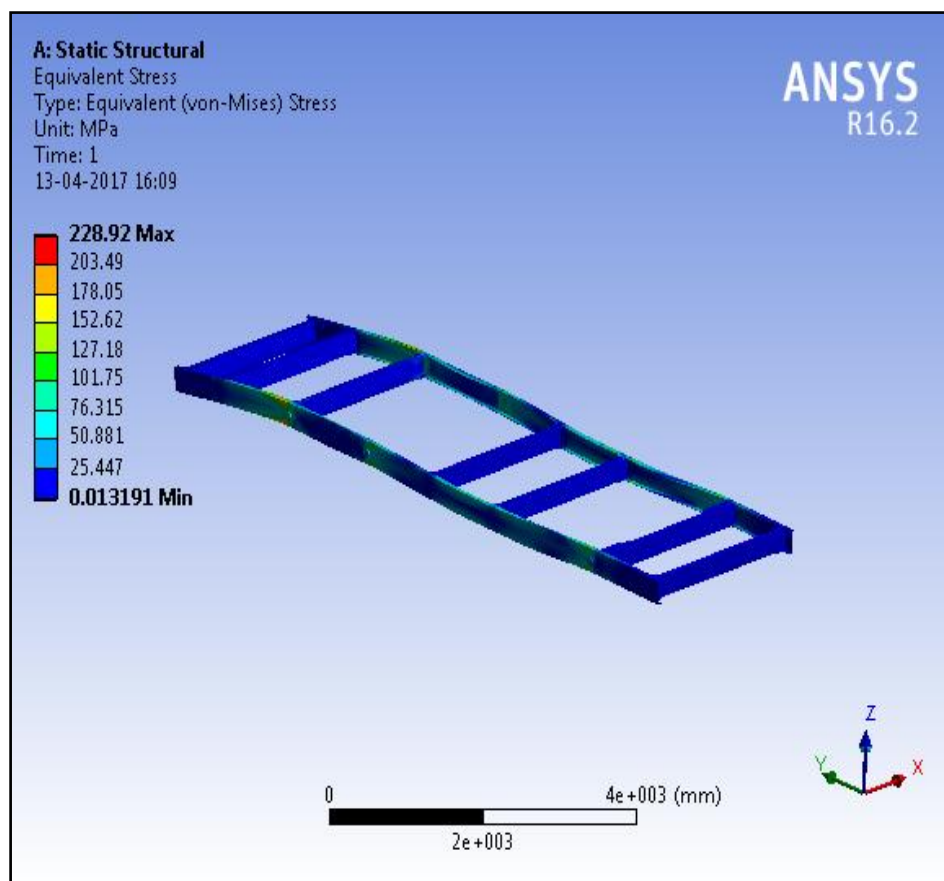

Figure 6: Stress Distributions of C-section

SHAPE OPTIMIZATION OF A HEAVYDUTY TRUCK CHASSIS FRAME USING CAE TOOLS

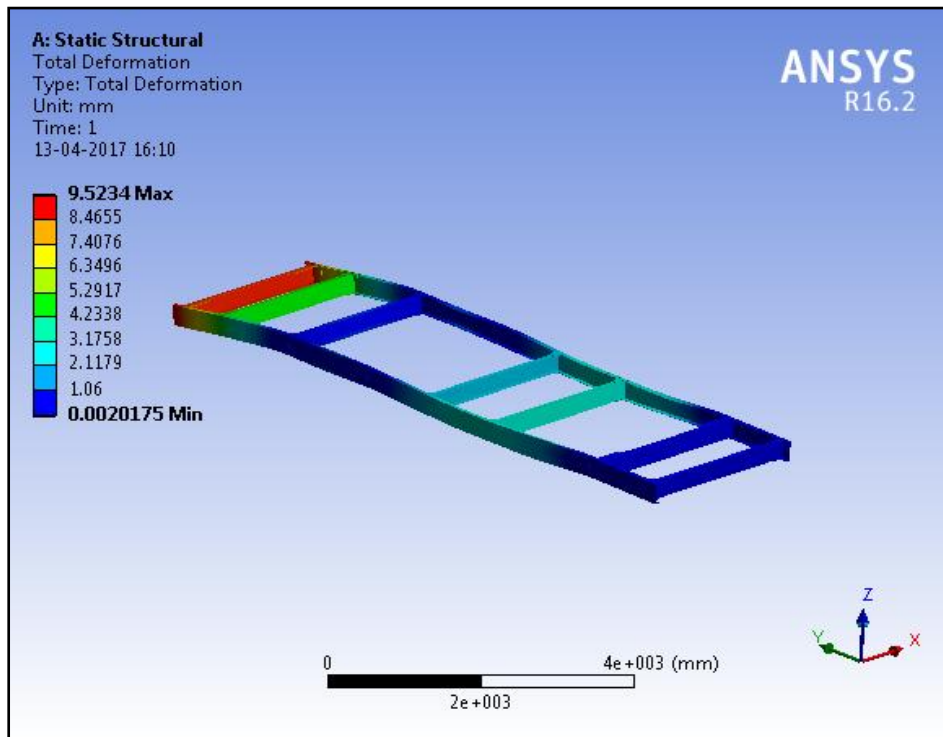

Figure 7: Displacement Pattern of C-section

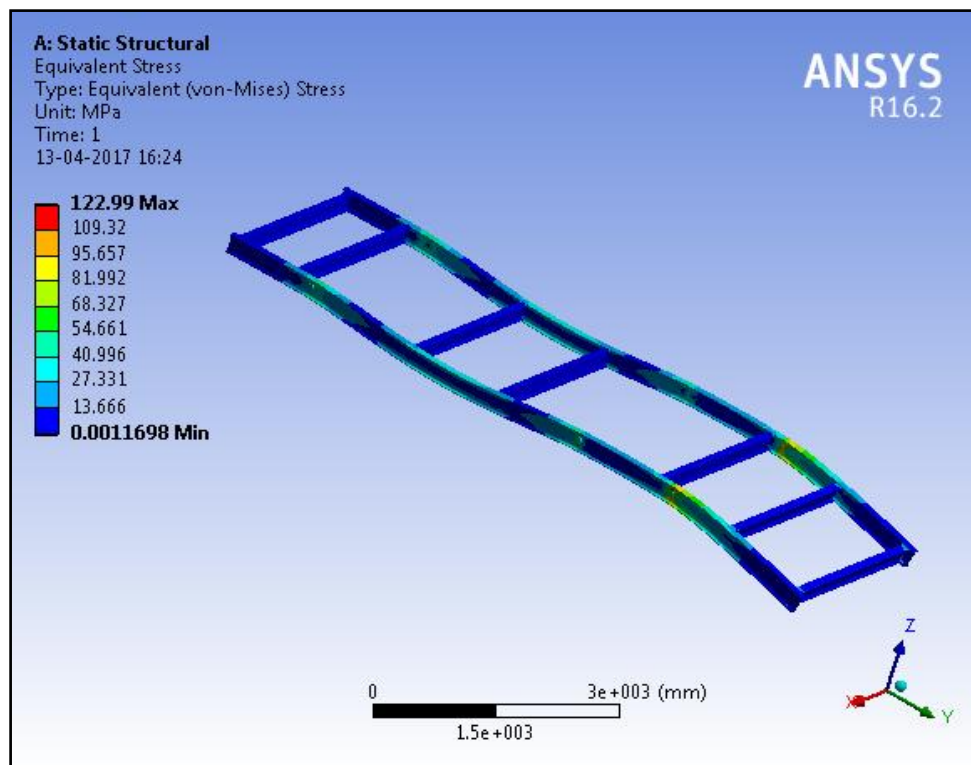

Figure 8: Stress Distributions of I-Section

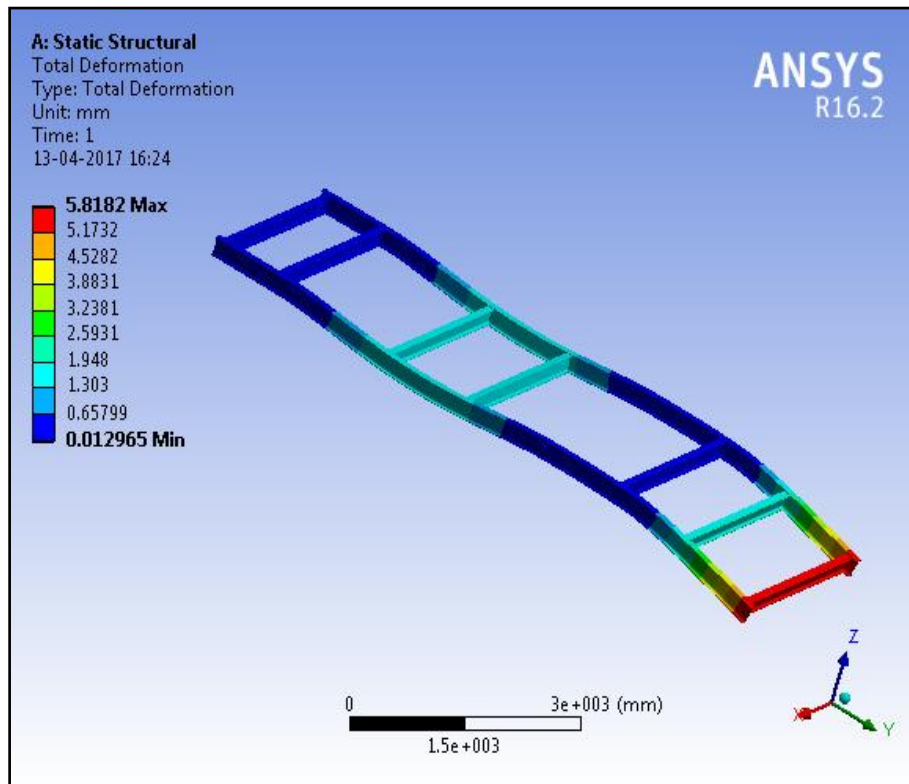

Figure 9: Displacement Pattern of I-Section

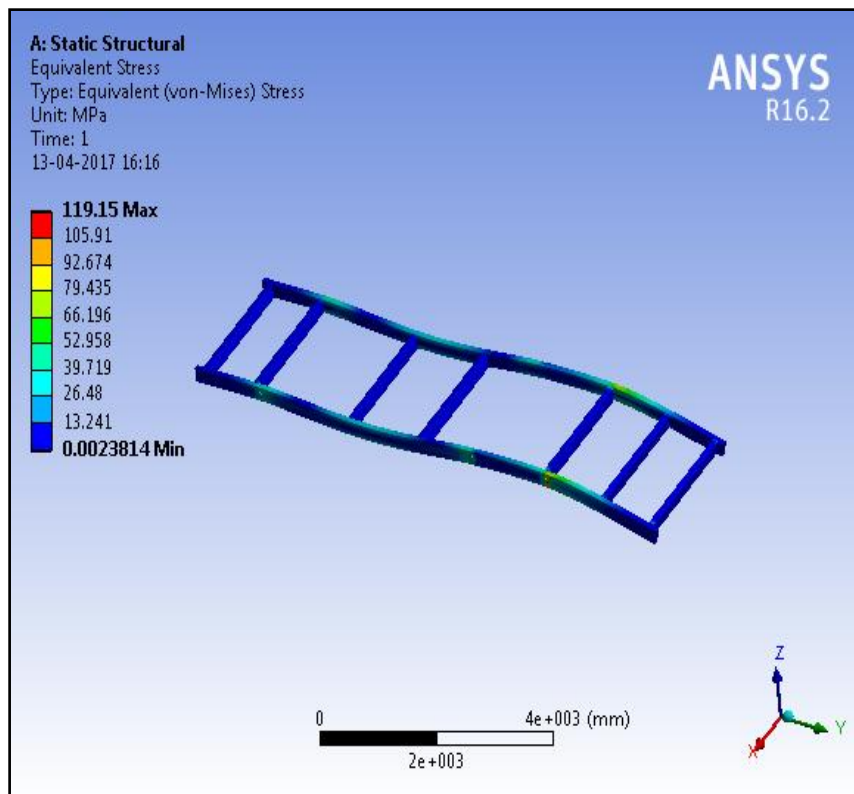

Figure 10: Displacement pattern of Hollow Section

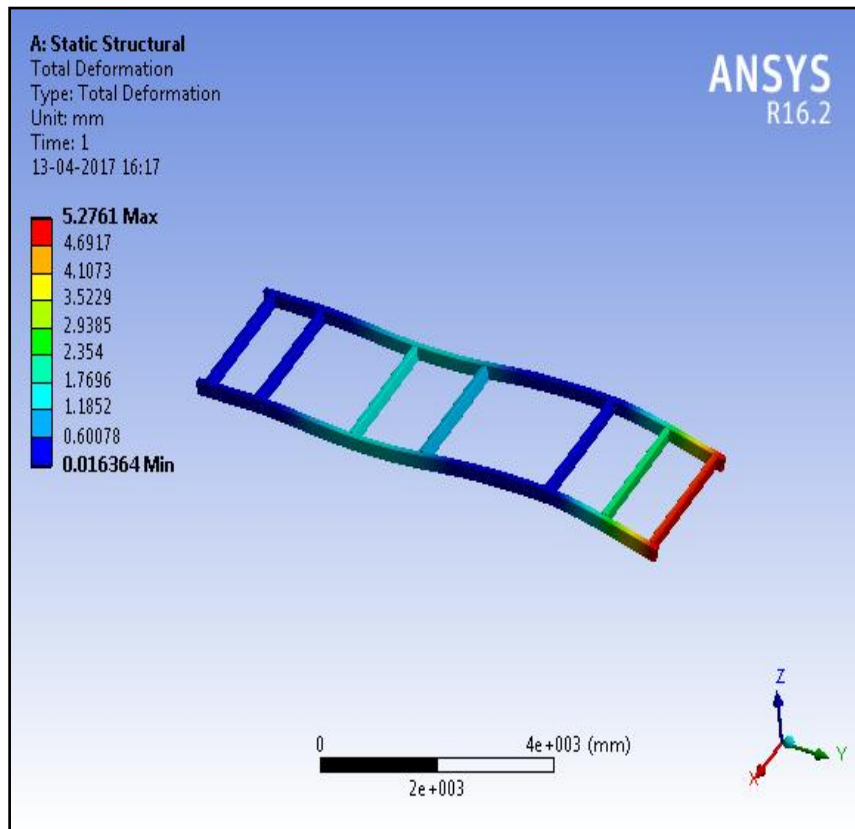

Figure 11: Stress distributions of Hollow Section

VI. RESULTS AND DISCUSSIONS

The Ladder chassis frame designed for the TATA 2518TC underwent thorough analysis using computer-aided engineering software NX, where three different cross-sections were considered. The structural analysis was conducted in ANSYS Workbench 16.2. Following this, size optimization was applied using Design Xplorer and Design of Experiments in ANSYS Workbench, with a focus on achieving a high strength-to-weight ratio.

The data obtained from the subjecting chassis frame to real-time loadings will provide valuable insights into the design's effectiveness and its ability to withstand varying conditions encountered during its service life. This comprehensive evaluation enables engineers to fine-tune the design if necessary and confidently finalize the Ladder chassis frame for the TATA 2518TC, ensuring that it meets the stringent requirements of heavy-duty truck operation.

Table 1: Results of Maximum Bending Moment, Section Modulus and Bending Stress.

Single rail Cross-sections	Maximum - Bending Moment (N.mm)	Section -Modulus (mm ³)	Bending stress (N/mm ²)
C- Channel Section	39474212	204.88	192.66
I-Section	39474212	396.58	99.54
Rectangular Section	39474212	492.5	80.15

Table 1 data provides essential information on the bending behavior and strength characteristics of the different single rail cross-sections analyzed in the study. These results are crucial in determining the most suitable cross-section for specific structural applications, ensuring optimal performance and safety.

Table 2: Percentage Error Variation of Stresses in Analytical and ANSYS workbench.

Single rail Cross-sections	Clapeyron's Theorem Bending stress (N/mm ²)	ANSYS Bending stress (N/mm ²)	Error Variation (%)
C- Channel Section	192.66	178.71	-7.2%
I-Section	99.54	101.43	+1.9%
Rectangular Section	80.15	86.04	+6.8%

Table 2 shows the variation of stresses in analytical and FE analysis for different single rail cross-sections: The table presents the comparison between the bending stresses calculated using Clapeyron's Theorem and those obtained through ANSYS finite element analysis. The corresponding percentage errors are also included, indicating the variance between the two methods. These stress comparisons are crucial for assessing the accuracy and reliability of the finite element analysis results and verifying the validity of the analytical approach.

Table 3: Stiffness to mass ratio of single rail for different cross sections

Single rail Cross-sections	Mass (Kg)	Load on each Rail (KN)	Maximum Deformation mm	Stiffness KN/mm	Ratio (N/Kg-mm)
Channel Section	213.33	153.281	8.30	18.467	86.56
I-Section	400.48	153.281	5.412	28.322	70.72
Rectangular Section	606.92	153.281	4.40	34.836	57.40

Table 3 provides the stiffness to mass ratio analysis for different single rail cross-sections: The table presents the Stiffness to Mass ratio for each cross-section, representing the relationship between the rail's stiffness and its mass. A higher stiffness-to-mass ratio indicates a more efficient and resilient rail design. Based on the data, the C-Channel Section exhibits the highest stiffness-to-mass ratio of 86.56 N/Kg-mm, followed by the I-Section with 70.72 N/Kg-mm, and the Rectangular Section with 57.40 N/Kg-mm. These values are crucial for assessing the structural performance and overall efficiency of the different cross-sections in terms of their ability to withstand loads while minimizing deformation. Engineers and designers can utilize this information to make informed decisions about selecting the most suitable cross-section for specific rail applications based on their desired stiffness and weight considerations.

Table 4 : Maximum load, stress, deformation, and stiffness of chassis frame for different cross sections

Chassis Frame Cross-sections	Mass (Kg)	Max. Load (kN)	Max. Stress (N/mm ²)	Maximum Deformation (mm)	Stiffness (kN/mm)
Channel Section	816.23	306.562	228.92	9.5234	32.19
I-Section	1516.6	306.562	122.99	5.8182	52.68
Rectangular Section	2217.5	306.562	119.15	5.2761	58.10

The table4 provides valuable insights into the Maximum load, stress, deformation and stiffness of chassis frame for different cross sections for each cross section. A higher stiffness-to-mass ratio signifies a more rigid and robust chassis design. Based on the data, the Rectangular Section exhibits the highest stiffness-to-mass ratio of 58.10 kN/mm, followed by the I-Section with 52.68 kN/mm, and the Channel Section with 32.19 kN/mm. Additionally, the table includes essential information such as the maximum stress and maximum deformation for each cross section under the specified load. These values are crucial for evaluating the structural performance and overall efficiency of the different chassis frame cross sections. Designers and engineers can use this data to make informed decisions when selecting the most suitable cross section for the chassis frame, considering factors such as strength, weight, and rigidity to meet specific performance requirements and safety standards.

VII. SIZE OPTIMIZATION OF THE CHASSIS RAIL AND CHASSIS FRAME

Table 5: Pre and Post Optimization Results of Single Rail for Different Cross Sections

Single rail Cross-sections	Pre – Optimum			Post – Optimum		
	Mass (Kg)	Max. Stress (MPa)	Max. Def (mm)	Mass (Kg)	Max. Stress (MPa)	Max. Def (mm)
Channel Section	213.33	178.71	8.30	144.81	231.44	10.74
I- Section	400.48	101.43	5.412	200.16	193.92	8.215
Rectangular Section	606.92	86.04	4.40	341.73	116.91	6.000

Table 5 presents the pre and post optimization results of different cross sections for a single rail: The table illustrates the comparison between the original (pre-optimum) and optimized (post-optimum) results for each cross section. After optimization, the mass of the single rail has reduced significantly, leading to a more lightweight structure. However, it's worth noting that, in some cases, the maximum stress and deflection have increased, which may indicate a trade-off between weight reduction and stress distribution. The post-optimum design still maintains structural integrity within acceptable stress and deflection limits.

These post-optimization results demonstrate the effectiveness of the design modifications, achieving a balance between weight reductions and maintaining the structural

performance of the single rail for each cross section. Engineers can utilize this data to make informed decisions on the most suitable cross section and optimization strategies to meet specific design criteria and performance objectives.

Table 6: Percentage values of mass, stress, and deformation results of single rail for different cross sections

Single rail Cross-sections	Percentage reduction in Mass	Percentage rise in Stress	Percentage rise in Deformation
Channel Section	32%	29.5%	30%
I - Section	50%	92%	34%
Rectangular Section	44%	36%	36%

Table 6 presents the percentage changes in various parameters: The table reveals the impact of optimization on the single rail's performance for each cross section. After optimization, there are significant reductions in the mass of the rail, indicating successful weight reduction efforts. However, it is essential to consider the trade-offs, as the percentage rise in stress and deformation also increased for some cross sections.

For the Channel Section, the optimized rail is 32% lighter, but it experienced a 29.5% increase in stress and a 30% rise in deformation. Similarly, for the I-Section, there was a 50% reduction in mass, but the stress and deformation increased by 92% and 34%, respectively. The Rectangular Section saw a 44% reduction in mass, but the stress and deformation rose by 36%.

Table 7: Strength to Mass Ratio for Single Rail before and After Optimization

Single rail Cross sections	Load carried by each rail in chassis frame = 153281 N					
	Pre – Optimum			Post - Optimization		
	Stiffness (N/mm)	Mass (Kg)	Ratio (N/Kg-mm)	Stiffness (N/mm)	Mass (Kg)	Ratio (N/Kg-mm)
Channel Section	18467	213.33	86.56	14272	144.81	98.55
I - Section	28322	400.48	70.72	18658	200.16	93.21
Rectangular Section	34836	606.92	57.40	25547	341.73	74.75

These results suggest that the optimization process has effectively reduced the rail's mass, which is beneficial for overall vehicle performance and fuel efficiency. However, the increase in stress and deformation indicates that there might be some trade-offs in terms of structural integrity and rigidity. Designers and engineers need to carefully balance weight reduction objectives with maintaining acceptable stress and deformation levels to ensure the rail's safety and performance under real-world operating conditions.

In summary, the optimization process has successfully achieved substantial reductions in rail mass for each cross section. However, the percentage rise in stress and deformation

must be carefully considered, and additional refinements might be necessary to achieve the desired balance between weight reduction and structural performance.

Table 7 presents the strength-to-mass ratio for single rail before and after optimization, along with the stiffness and mass values for each cross section: The table highlights the changes in strength-to-mass ratio after optimization for each cross section. The strength-to-mass ratio represents the balance between the rail's stiffness (strength) and its mass, with higher values indicating a more efficient and lightweight design.

After optimization, the mass of each rail has decreased significantly, resulting in improved strength-to-mass ratios for all cross sections. The post-optimization values demonstrate that the rails' stiffness-to-mass ratios have increased compared to the pre-optimization values. This indicates that the optimization process has successfully reduced the rail's weight without compromising its strength, resulting in more structurally efficient single rails for the chassis frame.

The increased strength-to-mass ratio implies that the optimized rails can carry higher loads relative to their mass, leading to enhanced overall performance and efficiency of the chassis frame. This optimization process is crucial for achieving better vehicle performance, fuel efficiency, and sustainability.

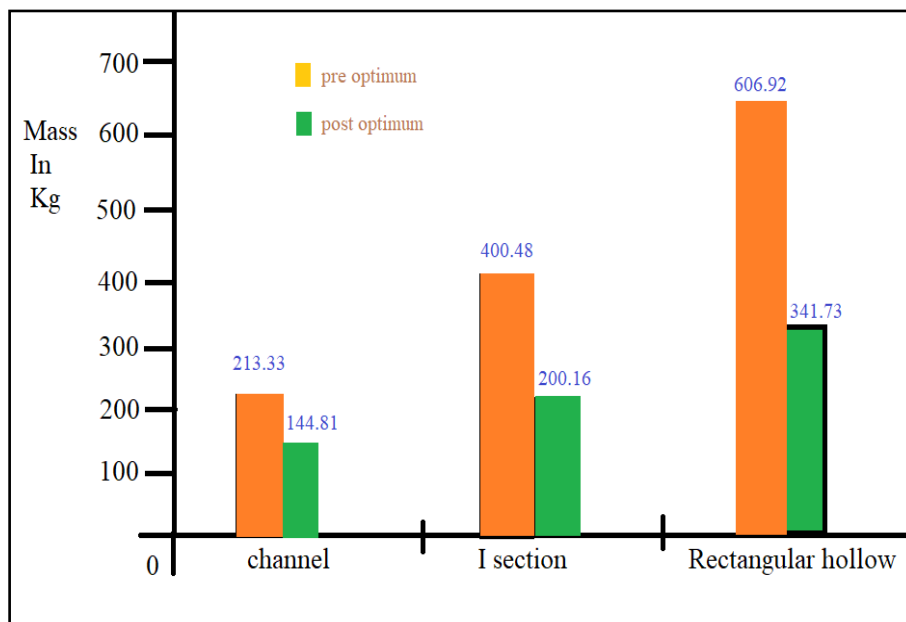

Figure 12: Reduction in Mass after Optimization

SHAPE OPTIMIZATION OF A HEAVYDUTY TRUCK CHASSIS FRAME USING CAE TOOLS

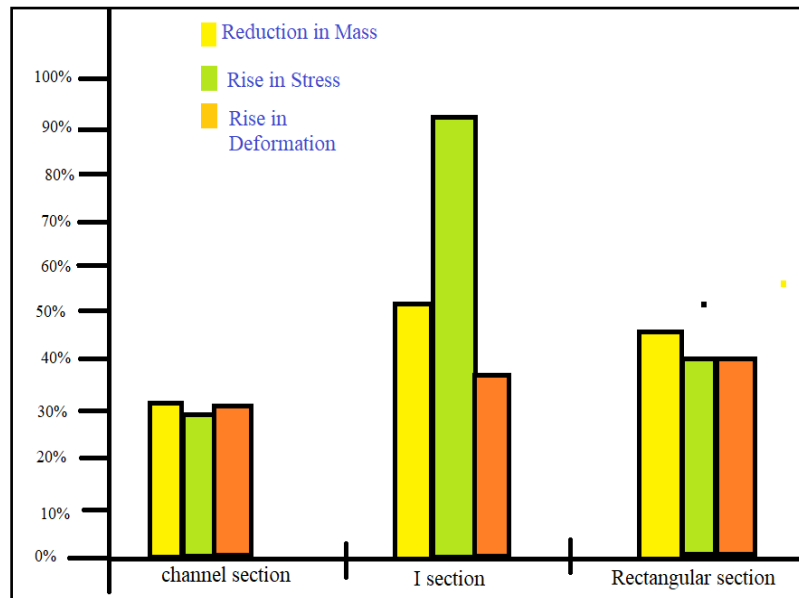

Figure 13: Reduction in Mass, Rise in Stress and Rise in Deformation for Different Cross-Sections.

Reduction in mass after optimization for different cross sections are shown in figure 12 and it is found that rectangular hollow section shows the maximum mass in Kg for pre and post optimum conditions. Figure 13 shows for Reduction in mass, rise in stress and rise in deformation for different cross-sections.

VIII. MODELLING AND ANALYSIS OF OPTIMIZED CHANNEL SECTION CHASSIS FRAME

From the above results it is confirmed that the channel section is performing well with high strength to weight ratio. As a final design optimized Channel section chassis frame is modelled and analyzed for manufacturing recommendations. The conclusion results are presented in figures 14, 15 and 16.

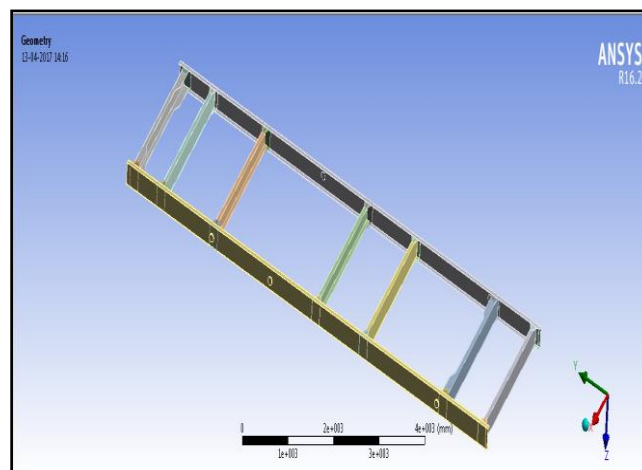

Figure 14: Optimized C-Section chassis frame

SHAPE OPTIMIZATION OF A HEAVYDUTY TRUCK CHASSIS FRAME USING CAE TOOLS

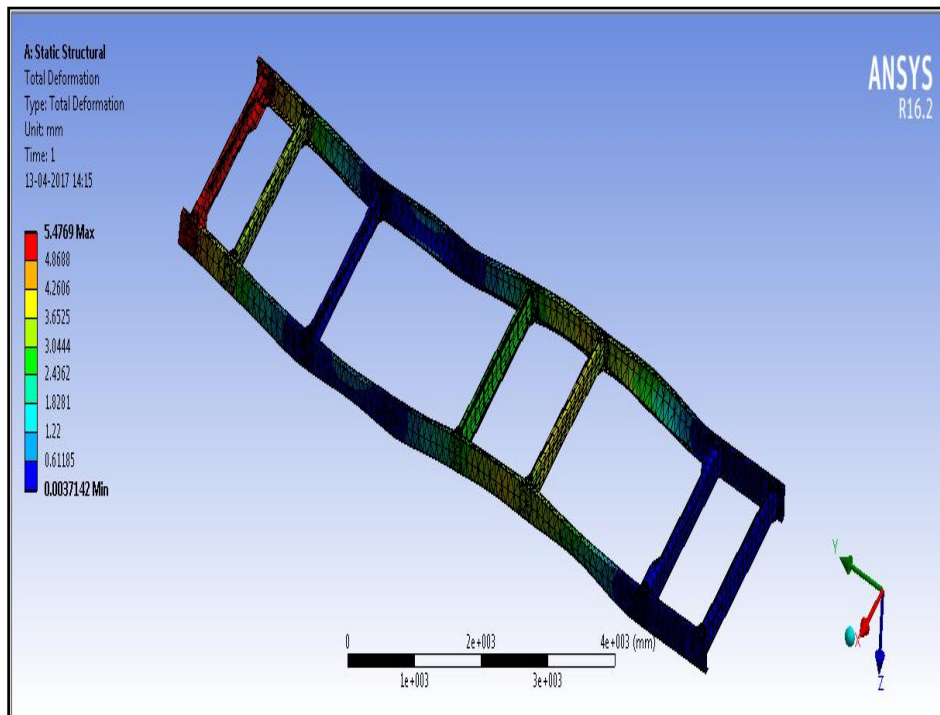

Figure 15: Deformation in Optimized Chassis Frame

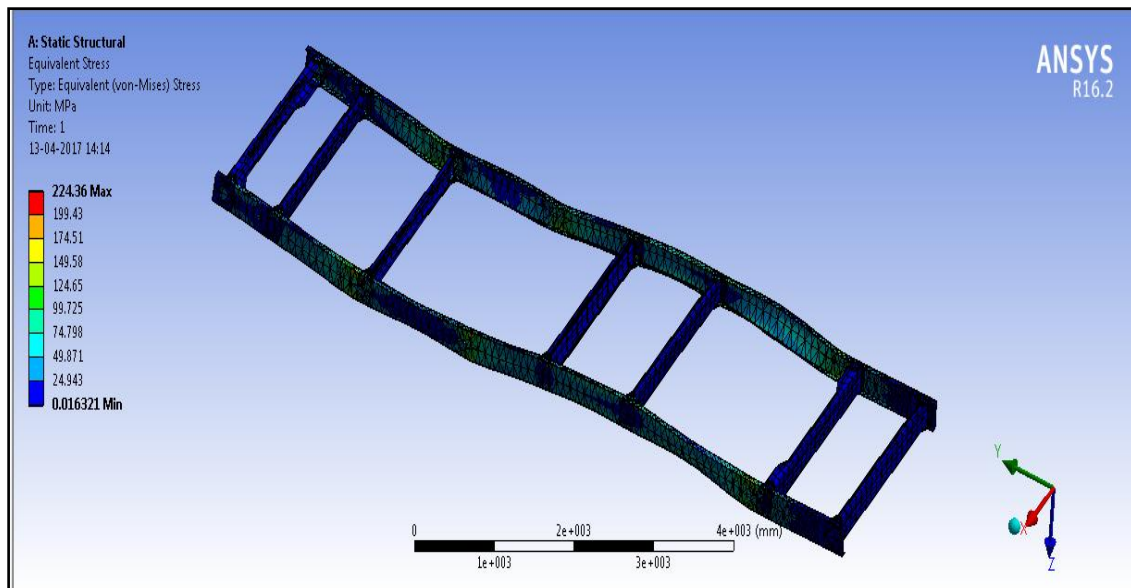

Figure 15: Stress variations in Optimized Chassis Frame with Channel Cross Section

Table 8: Channel Section Chassis frame results

Chassis Frame Channel Cross-section	Pre Optimum	Post Optimum	Percentage Gain/Loss
Top flange, t1	7 mm	7 mm	same
Bottom flange, t2	7 mm	7 mm	same
Web, t3	7 mm	3.5 mm	- 50%

Mass (Kg)	816.23	563.72	- 31%
Max. Load (KN)	306.562	306.562	same
Max. Stress (N/mm ²) < 260 MPa	228.92	224.36	- 2%
Maximum Deformation (mm) < 12 mm	9.5234	5.4769	- 42.5%
Flexural Stiffness (or) Strength (KN/mm)	32.19	55.97	+ 74%
Strength to Mass ratio (N/Kg-mm)	39.44	99.28	+151%
Strength to Weight ratio (N/N-mm)	4.02	10.12	+151%

The pre and post optimum results and percentage error results are shown in table 8. The table presents a comprehensive comparison of the chassis frame's channel cross-section before and after optimization, along with the percentage gain or loss in various parameters: Overall, the optimization process for the chassis frame's channel cross-section has proven highly effective in achieving weight reduction, increasing stiffness, and enhancing the strength-to-mass and strength-to-weight ratio. These improvements result in a more robust and efficient chassis frame, contributing to improved vehicle performance and safety.

IX. CONCLUSIONS

Weight plays a crucial role in enhancing the riding qualities and overall cost efficiency of automobile engines. Notably, about twenty percent of the truck's kerb weight is attributed to the chassis frame. The chassis serves as a pivotal component in automobiles, acting as the strength of heavy vehicles. Under different operating conditions, it bears the maximum load and serves as a structural platform that connects the front and rear suspensions, while preventing too much deflection. As a result, weight and strength stand out as the two key criteria guiding chassis design. Based on the conducted study, several conclusions have been drawn:

- 1. Flange Thickness:** The top and bottom flanges maintain the same thickness of 7 mm both before and after optimization, ensuring consistency in these structural elements.
- 2. Web Thickness:** The web thickness, denoted as "t3," was reduced from 7 mm in the pre-optimum state to 3.5 mm after optimization, resulting in a significant 50% reduction. This reduction helps in achieving weight savings and contributes to the overall improvement of the chassis frame.
- 3. Mass:** The mass of the chassis frame was substantially reduced from 816.23 Kg in the pre-optimum state to 563.72 Kg after optimization, representing a remarkable 31% decrease. This reduction in mass is crucial for enhancing the vehicle's fuel efficiency and overall performance.
- 4. Max. Load and Stress:** The maximum load carried by the chassis frame remains the same in both states, with a load of 306.562 KN. Additionally, the maximum stress experienced by the frame was slightly reduced from 228.92 N/mm² in the pre-optimum state to 224.36 N/mm² after optimization, resulting in a modest 2% reduction.

5. **Maximum Deformation:** The maximum deformation experienced by the frame decreased significantly from 9.5234 mm in the pre-optimum state to 5.4769 mm after optimization, indicating a substantial 42.5% reduction in frame flexibility.
6. **Flexural Stiffness and Strength-to-Mass Ratio:** The flexural stiffness (or strength) of the chassis frame showed substantial improvement, increasing from 32.19 KN/mm in the pre-optimum state to 55.97 KN/mm after optimization, representing a remarkable 74% gain.
7. The strength-to-mass ratio also exhibited significant enhancement, rising from 39.44 N/Kg-mm in the pre-optimum state to 99.28 N/Kg-mm after optimization, signifying a notable 151% increase. This improvement highlights the frame's ability to carry higher loads relative to its reduced mass.
8. **Strength-to-Weight Ratio:** The strength-to-weight ratio experienced a parallel enhancement, increasing from 4.02 N/N-mm in the pre-optimum state to 10.12 N/N-mm after optimization, also displaying a substantial 151% gain.

REFERENCES

- [1] Agarwal, L. Mthembu, "FE design analysis and optimization of heavy-duty truck chassis using sparse grid initialization technique", *Materials Today: Proceedings*, Elsevier, Volume 60, Part 3, 2022, Pages 2084-2092, <https://doi.org/10.1016/j.matpr.2022.01.471>
- [2] S. Nandhakumar , S. Seenivasan , A. Mohammed Saalih , Muhammed Saifudeen "Weight optimization and structural analysis of an electric bus chassis frame" Volume 37, Part 2, 2021, Pages 1824-1827, *Materials Today Elsevier*, <https://doi.org/10.1016/j.matpr.2020.07.404>
- [3] HongshenZhang, Gan Huang, and Dali Yu "Numerical modeling for the frame structure of light van-type electric truck", June 17, 2020, Sage publications, Science progress <https://doi.org/10.1177/0036850420927204>
- [4] ShuvodeepDe, Karanpreet Singh,JunhyeonSeo , Rakesh K Kapania, Erik Ostergaard , Nicholas Angelini and Raymond Agüero, "Structural Design and Optimization of Commercial Vehicles Chassis under Multiple Load Cases and Constraints" Conference Paper · January 2019, <http://dx.doi.org/10.2514/6.2019-0705>
- [5] Tidke, N.; Burande, D.H. Analysis of HCV Chassis using FEA. *Int. Eng. Res. J.* 2017, 1–5, SpecialEditionPGCON-MECH-2017.<http://www.ierjournal.org/pupload/mechpgcon2017/Analysis%20of%20HCV%20Chassis%20using%20FEA.pdf>
- [6] S.N. Vijayan, N.; SendhilKumar, S.; Kiran Babu, K.M. "Design and analysis of automotive chassis considering cross design and analysis of automotive chassis considering cross-section and material". *International Journal of Current. Research.* 2015, Vol. 7, pp. 15697–15701.<https://www.researchgate.net/publication/317041236>
- [7] Stalin, B. Structural Analysis of Front-End Cross Bar of a TATA407 Chassis Frame. *Bonfring Int. J. Ind. Eng. Manag. Sci.* **2016**, 6, 120–122. <http://dx.doi.org/10.9756/BIJIEMS.7540>
- [8] S.Prabakaran, K.Gunasekar, "Structural Analysis of Chassis Frame and Modification for Weight Reduction. *Int. J. Eng. Sci. Res. Technol.* **2014**, 3, 1–6. <http://www.ijesrt.com>, International Journal of Engineering Sciences & Research Technology, pp. 595-600.
- [9] AlirezaArabSolghar,ZeinabArsalanloo(2013), <https://www.ijedr.org/papers/IJEDR2003059.pdf>
- [10] Patel, V.; Patel, V.V.; Patel, R.I. "Structural Analysis of Automotive Chassis Frame and Design Modification for Weight Reduction". vol. 01, Issue .03 2012, 1–6. [Google Scholar] [CrossRef]<https://www.ijert.org/structural-analysis-of-automotive-chassis-frame-and-design-modification-for-weight-reduction>, DOI: 10.17577/IJERTV11S3065
- [11] İbrahim Kutay Yılmazçoban Yaşar Kahraman Kutay Yılmazçoban, Yasar Kahraman "Truck Chassis Structural Thickness Optimization With The Help Of Finite Element Technique" Volume: 1 Issue: 3 - Volume: 1 Issue: 3, 0 - 0, 23.07.2016 <https://dergipark.org.tr/en/pub/tojsat/issue/22702/242337>