

IOT BASED SMART PARKING

Abstract

There is currently a serious issue with car parking systems in several multiplex systems. There are several parking spaces, thus finding a spot to park a car requires searching all lanes. In addition, a lot of men's labour is required for this operation, which requires a lot of expenditure. Therefore, it is necessary to create a system that shows clearly which parking space is available in any lane. Every lane in the project has an infrared transmitter and receiver as well as an LED and LCD display. In order to choose which slot to enter to park the automobile, the user entering the parking area can examine it using the IoT module involved.

Traditionally, intelligent monitoring systems for parking systems are absent. Parking spaces are watched over by people. All automobiles enter the parking lot, wasting time as they look for a spot to park. It can occasionally cause obstruction. When there are several parking lanes and each lane has several parking spaces, the situation gets worse. Utilising an automated system will reduce the need for human labour when monitoring parking spaces.

Here, the car in that parking space is being found using IR sensors. Therefore, if it is occupied, that information is available on the internet, and open slots are also displayed, allowing one to reserve a spot before arriving by using IoT. To prevent waiting, do this. Our controller is an AT89S52, and an IoT module is connected to allow us to view the slots online.

For this project, a controlled 500mA, 5V power source is used. For relays, unregulated 12V DC is utilised. Voltage regulation is accomplished using the 7805 three terminal voltage regulator. The secondary output of the 230/12V step down

Authors

Dr. Santhi Chebiyyam

Assistant Professor & HOD
Electronics & Communications Technology
Loyola Academy, secunderabad.
cheb.santhi@gmail.com

K. Sitarama Sastry

Assistant Professor
Electronics & Communications Technology
Loyola Academy, secunderabad.
sastry75@gmail.com

transformer's ac output is rectified using a bridge type full wave rectifier.

Keywords : IoT; Parking slots; IR sensors

I. INTRODUCTION

Two of the most important problems in metropolitan areas are parking and business control systems. In ultramodern metropolises, it might be delicate for motorists to gain parking spots due to the rise in the number of individualities using private vehicles.

City itineraries may see this as an occasion to apply Internet of effects(IoT)-grounded smart parking in a busy civic terrain to ameliorate the effectiveness of their parking spaces and lower hunt times, business traffic, and accidents.

For case, if motorists are notified about the vacuity of parking spots for their intended destination and the neighbouring spots, parking troubles and business traffic can be soothed using smart parking and the Internet of effects.

Following the rapid-fire rise of seeing technology, multitudinous ultramodern communities have chosen to borrow colorful IoT- grounded systems for monitoring. As an illustration, some parking programmes claim that IoT smart parking systems give residers real- time information about parking spots that are available.

Such systems need to deploy efficient sensors in parking lots in order to accommodate residential and data processing units and quickly collect real-time data from several sources. Some major daily parking issues include:

- Parking spaces are hard to come by, especially in cities.
- Using available parking spots incorrectly
- Finding open parking places requires extra time and petrol.
- It's challenging to locate automobiles in large parking lots
- The primary cause of traffic congestion is unused parking spots.
- Business parking lots are replaced with passenger parking
- Inadequate parking
- Effective management of disabled spots and underutilized private parking lots
- The consequences of using too much petrol when hunting for parking
- Ambiguous parking rules.

Parking issues like these are all quite typical in Indian cities and villages. However, things don't have to be that way. Smart Parking System can help with the issue.

II. EMBEDDED IOT SYSTEMS

An bedded system is a computer that carries out a particular, specified task. The air conditioner, VCD player, DVD player, printer, fax machine, mobile phone, and other bias are samples of bedded systems. Each of these appliances will come equipped with a CPU, specialized attack, bedded software, and attack that the processor uses to meet the demands of the operation. The bedded software is also appertained to as" firmware".

The desktop or laptop computer is a versatile piece of technology. It may be used for multitudinous different goods, analogous as word processing, account, creating software,

and playing games. The software for bedded systems, still, is streamlined constantly. Because they are so specialized, bedded systems can't be designed to carry out fresh functions.

The resources of bedded systems are truly limited, particularly the memory. Generally, they don't have spare storage bias like CDRoms and droopy discs. Systems that are bedded are subject to strict time constraints. A certain task has a deadline that it must meet. Some bedded systems, appertained to as real- time systems, have strict deadlines. The consequences of missing a deadline might be disastrous, including death or property damage. The amount of power that bedded systems can use is limited. Because multitudinous bedded bias are powered by batteries, the power consumption must be exceedingly low.

Some bedded systems need to operate under harsh environmental conditions, analogous as extremely high temperatures and humidity.



Figure 1: Smart Parking

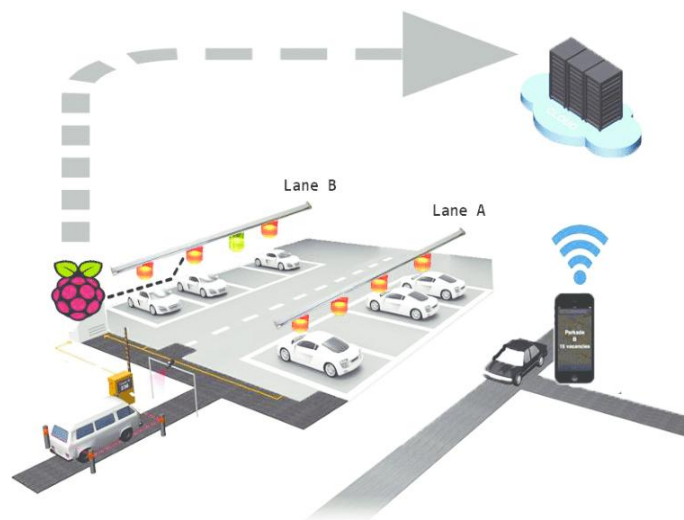

Figure 2: Parking Systems with Mobile Control

III. BLOCK DIAGRAM

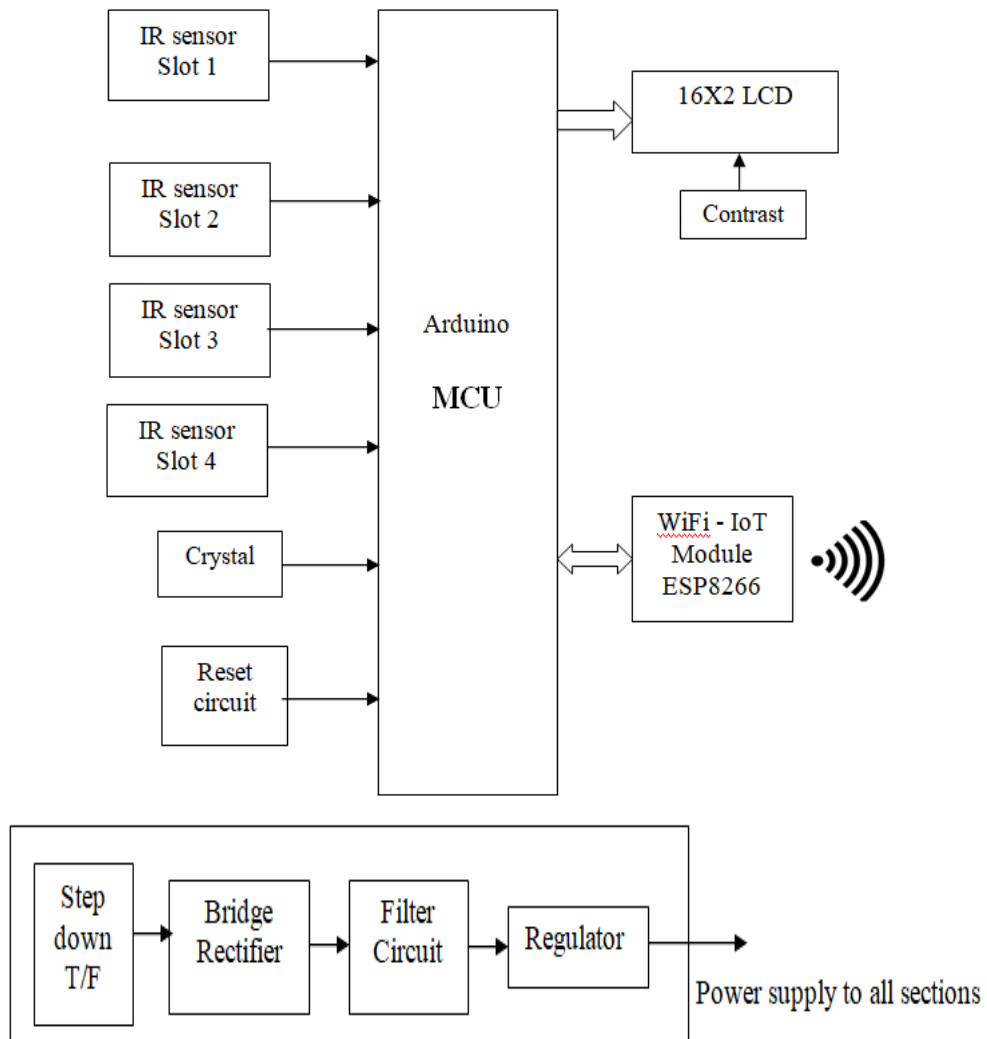

Figure 3: Block Diagram

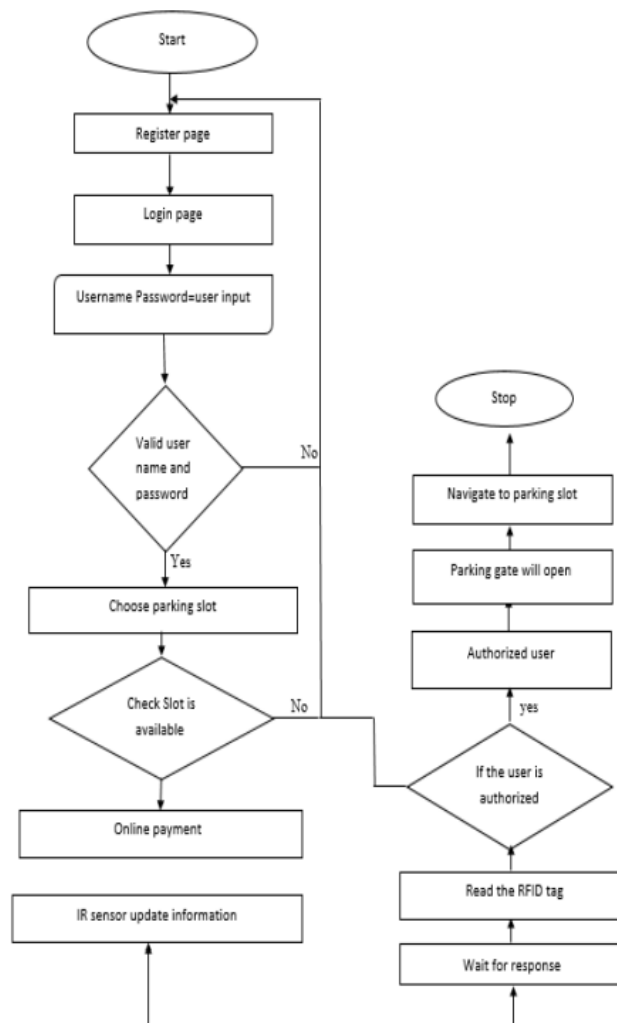

Figure 4: Algorithm

IV. SOFTWARE & HARDWARE USED

These programmes are used to carry out this project:

- Proteus simulation for circuit design
- The compilation portion of the Arduino compiler

1. **Proteus:** It is a software package that includes PCB designing, simulation, and schematic design.

- ISIS is the programme used to create schematics and run real-time circuit simulations. The simulation provides real-time simulation by allowing human interaction while it is running.
- ARES is employed in PCB design. It includes the ability to display output in 3D along with the designed PCB and components.
- The product's 2D drawings can also be created by the designer.

- 2. IR Proximity Sensor:** This IR Proximity Sensor is a multipurpose infrared detector that can be used for a variety of operations similar as line seeing, fire discovery, colour discovery, handicap discovery, and encoder seeing. The detector generates a digital signal.

When anything is placed in front of the detector, it produces a digital affair sense one(5V), and when nothing is placed in front of it, it produces a sense zero(0V). The presence of an item is indicated by an intertwined LED. To read the detector affair, this digital affair can be fluently connected to an Arduino, Raspberry Pi, AVR, PIC, 8051, or any other microcontroller.

Since IR detectors are particularly sensitive to ambient light, the IR detector on this detector is adequately covered to reduce the effect of ambient light on the detector. The maximum range of the detector is between 40 and 50 cm indoors and between 15 and 20 cm outside.

- 3. LCD Screen:** An TV panel has two lines, each with 16 characters. A 5x7 fleck matrix is used to produce each character. The power force voltage and whether dispatches are displayed in one or two lines affect display discrepancy. This is why the leg labelled Vee receives a variable voltage of 0- V_{dd} . Trimmer potentiometers are generally used for this purpose. Some display types may include an intertwined backlight made of blue or green LEDs. As with any LE diode, a resistor for current limitation should be used when in use.

V. RESULT

The figure: 5 shows prototype of smart parking system for smart cities in which the parking slot availability is shown through a LED / LCD display.



Figure 5: Prototype of Smart parking System

The figure: 6 & 7 shows the IR sensors used for identification of parking slot availability or the slots filled with cars in the parking. Each slot will be given slot number and a sensor identifies the vehicle and displays the availability on LED / LCD screen connected in the system.

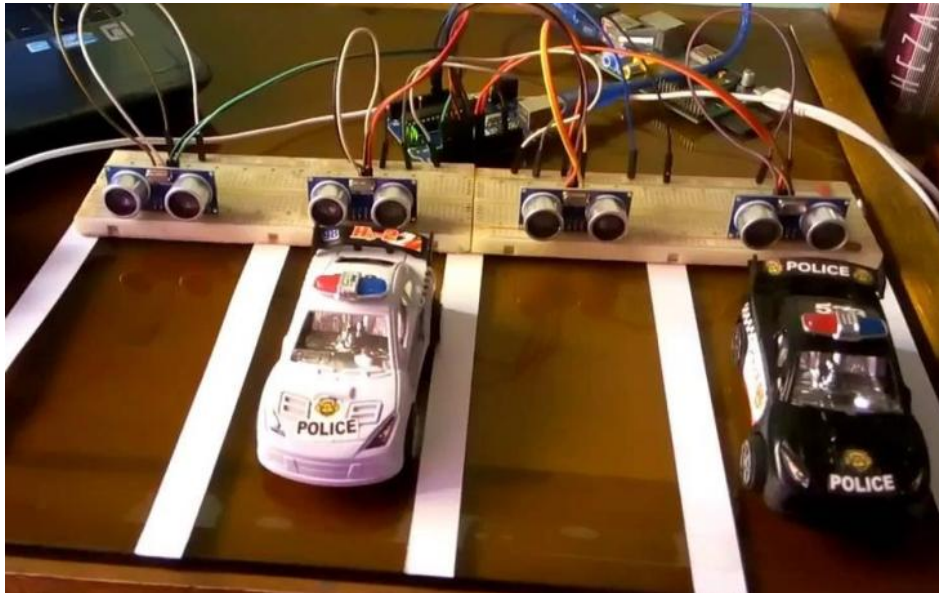

Figure 6: Smart Parking using IR Sensors

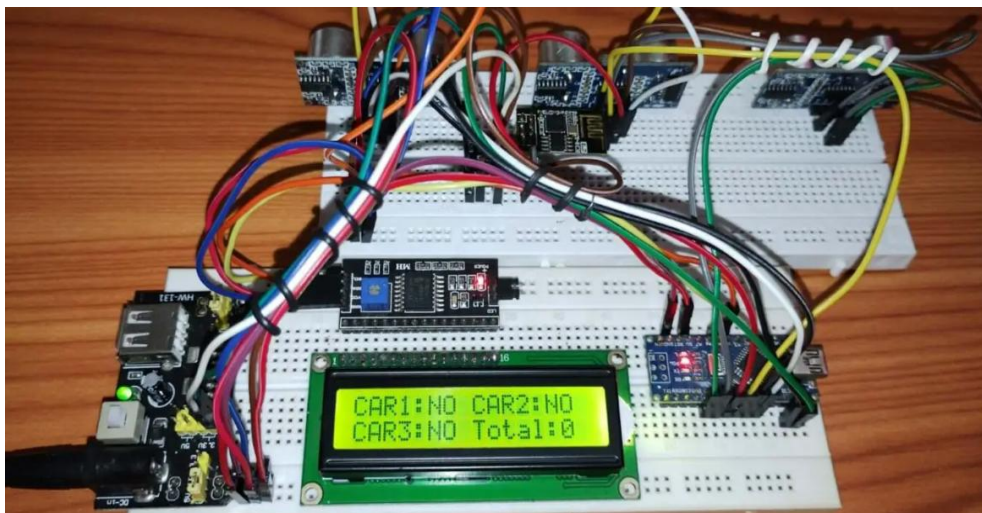

Figure 7: Display of availability of parking slot

VI. CONCLUSION

The "IOT Based Smart Parking System" project was successfully developed and put through testing. It was created by merging functionality from every piece of hardware used. Every module's existence and thoughtful placement contribute to the unit's optimal performance. Second, the project was effectively completed with the aid of cutting-edge ICs and developing technologies.

REFERENCES

- [1] Supriya Shinde¹ et.al, "IOT Based Parking System Using Google", I-SMAC, 2017, pp. 636–634.
- [2] "Advanced CAR Parking System Using Arduino", ICACCSS, 2017, Hemant Chaudhary, et.al.
- [3] "Smart urban parking deducting system" by Jennifer C. Dela et.al was published in ICSCE, 2016, pp. 370-373.
- [4] "Effective Car Parking Reservation System Based on Internet of Things Technologies," by Pavan Kumar Jogda et.al, Volume 6, Pages 140–142, BIJSESC.
- [5] "Android Based Smart Car Parking System" by Prof. Yashomati R. Dhumal, et.al, IJREEIE, Volume 5, Issue 3, March 2016, Pages 1371–74.
- [6] Faiz Ibrahim Shaikh, et.al, " Smart Parking System based on embedded system and sensor Network" IJCA, vol.140.pp.45-51.Apr-2016.
- [7] "A Privacy-Preserving Pay-by-Phone Parking System," by Ricard Garra, et.al, Seb.IEEE-TVT, Dec. 2016, pp. 1–10.
- [8] "Smart parking Guidance, Monitoring and Reservation: A Review," by Amir O. Kotb, et.al, IEEE-ITSM, April 2017, pp. 6–16.
- [9] Ching-Fei Yang, et.al, "Iparking -a real-time parking space monitoring and guiding system", Elsevier, pp. 301–305, April 2017.
- [10] "Urban Intelligent Parking system based on Parallel Theory", IEEE-ICNC, 2016, by Fei-Yue Wang, et.al.

