

DIFFERENT ENERGY HARVESTING MECHANISMS AND THE ROLE OF RF ENERGY HARVESTING APPROACH

Abstract

Energy harvesting (EH) is recognized as the best alternative for conventional batteries to provide sufficient power that to enable low-power gadgets. Energy harvesting is an approach of utilizing available energy emitted from various ambient sources and converting that into electrical DC. This chapter focuses on various energy harvesting mechanisms and their advantages and disadvantages. The role of radio frequency energy harvesting (RFEH) and a device such as Rectenna that supports for RF energy harvesting mechanism has also been highlighted. The different applications of rectenna in wireless energy harvesting (WEH), wireless power transmission (WPT), and solar power transmission (SPT) are deliberated briefly. Besides this, also explains the utilization of rectenna for various real-time applications.

Keywords: Energy harvesting; ambient energy; radio frequency energy harvesting; rectenna; wireless energy harvesting; wireless power transmission;

Authors

Dr. Daasari Surender
Department of Electronics and
Communication Engineering
Vaageswari College of Engineering
Karimnagar, Telangana, India
surender.daasari@gmail.com

Dr. Venkata Reddy Adama
Department of Electronics and
Communication Engineering
Vaageswari College of Engineering
Karimnagar, Telangana, India
venkat7641@gmail.com

I. INTRODUCTION

Wireless systems have seen significant progress as technology has advanced due to their ability to automate the architecture and decrease hardware complexity, and systems cost. Wireless technology has been extensively utilized to communicate and power transfer to other wireless gadgets for decades. Wireless technology improvements have greatly broadened the scope of its uses in various fields. As a result, the use of electronic components has risen, as has the power demanded to charge them. Continuous energy is required for the proper running of these gadgets; yet, it is impossible to give limitless power to these devices using conventional means such as a battery or wired cables. Furthermore, a battery's lifetime is limited, necessitating frequent battery changes. This raises the additional costs on the system's functioning and can make environmental damage. It is sometimes challenging to replace a battery that has been placed in an unreachable location. To circumvent these constraints, energy harvesting (EH) approaches have gained widespread interest [1].

II. ENERGY HARVESTING APPROACH

Energy harvesting (EH) is the process of absorbing available energy from the environment around a system and converting it to a form of electrical energy suitable for powering low-power electronic equipment. As a result, the EH method may be a preferable option for powering battery-free gadgets. The applications could be found in sensing and implantable devices, where charging such devices with batteries or wired cables is a challenge. Furthermore, these EH techniques are more useful if replenishing a battery in devices mounted in remote locations such as hill stations is impossible.

There are two different kinds of energy harvesting strategies: ambient source of energy harvesting and dedicated source of energy harvesting. The harvesting system in the first technique uses renewable energy from nearby sources, while in the second technique, a specialized source of energy is created to supply the appropriate amount of energy for consumer electronics over free space without polluting the environment.

Several energy harvesting technologies based on the first technique exist, that gather energy from inexhaustible sustainable energy sources such as vibrations, solar, thermal, acoustic, radio frequency (RF), wind, and so on [7-28]. These renewable energies are abundant and can be obtained from the surrounding air. Various energy harvesting methods include:

Piezoelectric
Photo-voltaic
Thermal
Acoustic
Radio frequency (RF)
Wind etc.

- 1. Piezoelectric Energy Harvesting:** Mechanical tension, pressure, and vibrations are used to generate electricity in this approach. The mechanical EH produced by piezoelectric transducers is compact and lightweight. However, the transmit power is dependent on the

object's vibration/motion, and the power output from the harvesting system is highly inconsistent when the vibrations are unstable. As a result of the variance in input power, the conversion efficiency is quite low [2, 3, 4, 5, 6].

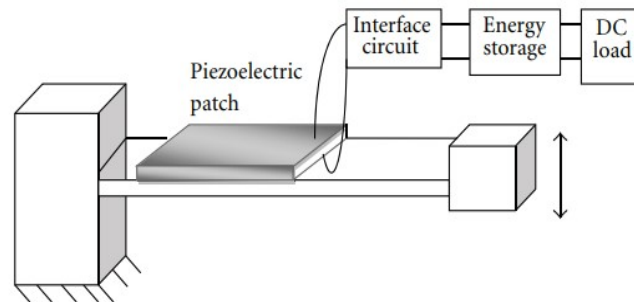

Figure 1: Block diagram of a Piezoelectric energy harvesting system [6].

In piezoelectric energy harvesting through vibration, an object remains suspended by an electron beam with a piezoelectric coating on the top. The piezoelectric lever is mechanically distorted as the mass vibrates, resulting in the generation of a voltage.

Figure 1 depicts a piezoelectric system made up of a piezoelectric patch glued to the surface of a cantilever beam that is undergoing alternate deformation. When the electron beam gets started by mechanical vibration in the host framework, high strain is induced in its piezoelectric material, and an alternating current (AC) develops within the electrodes. An interface circuitry then demands the AC voltage to guarantee that the harvested energy is transferred to a storage component or that the required load constraints are met. Nonlinear interface circuits are the latest breakthrough in conditioning circuitry, designed specifically to maximize output power.

2. Photo-voltaic Energy Harvesting

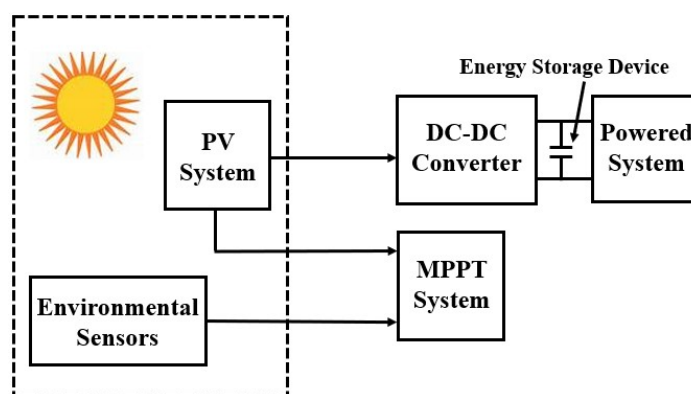

Figure 2: Block diagram of a Photo-Voltaic Energy Harvesting System [11].

Figure 2 shows the photovoltaic energy harvesting system, where in which photons from the sun or other unusual light sources are transformed into electricity in this process. Photons are harvested using photovoltaic panels. This is a traditional and commercially reputable harvesting practice. These panels, ranging in extent from a few

square centimeters to a few square meters, are composed of a complex framework of PV cells. Each PV solar cell is composed of a monocrystalline or polycrystalline compound semiconductor wafer structure. Two thin semiconductor wafers, one P-type and the other N-type are produced separately for the structure. When the two wafers are stacked on top of one other, the natural reaction between the two semiconductor kinds creates a depletion zone that reaches equilibrium without generating any electricity. When light photons flow through the PV cell and interact with semiconductor wafers, they release enough energy to upset the depletion region's equilibrium. As a result of this action, a short electrical current is generated. Due to the persistent presence of light, however, this interaction continues continuously and can generate vast amounts of electrical DC energy. This DC energy must be converted to AC power using an inverter to be compatible with modern power transmission equipment, such as the outlets in your home. This approach outperforms all other energy harvesting devices in terms of output power. However, the system's ability to harvest depends mostly on the amount of light present as well as the surrounding conditions. The greater the surface area available for sunlight to permeate the PV cells, the more solar energy is harvested, intuitively. Harvesting energy necessitates a special type of setup that cannot be used in an indoor environment. This is the main limitation of the PV energy harvesting system [2,3, 7-11].

3. **Thermal Energy Harvesting:** Electricity is generated using this method based on temperature variations or gradients. The mechanism creates power as long as there is a temperature difference. Otherwise, the generated voltage is lost due to leakage current. This type of energy is more readily available in large quantities, but the conversion of this energy to obtain sufficient output power from this collecting device is challenging. Furthermore, harvesting devices are inextricably linked to all other types of energy-gathering devices. As a result, to generate an acceptable amount of output power from this thermal energy harvesting system, a vast area is required [2-4, 12-16]. The block diagram of the thermal EH system is presented in Figure 3.

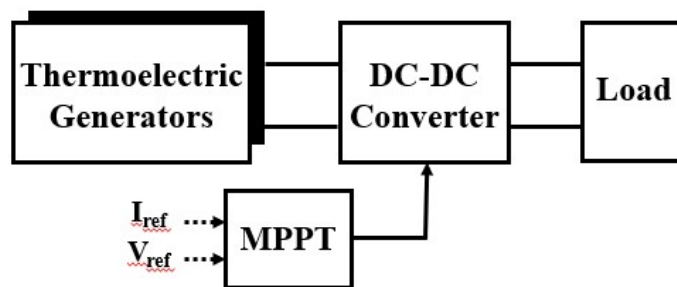

Figure 3: Block diagram of a Thermal Energy Harvesting System [16].

There are numerous ways of improving the amount of energy generated by thermoelectric generator (TEG) devices, one of which is to enhance the voltage boost converter produced and to model different TEG arrays based on the required energy. Because of the variation in a temperature gradient, a TEG device functions under a variety of conditions that are difficult to manage. Because of the temperature difference, the resistance that is detected within the gadget varies, generating a disparity that exists between the TEG gadget and the load. Without the Maximum Power Point Tracking

(MPPT) algorithm, this difference will prevent the conditions for maximum power operation.

The MPPT algorithm enhances the harvesting system efficiency by operating it at the optimal operating point for extreme power generation. MPPT is a methodology that drives the voltage converter using a given pulse to track the greatest PowerPoint, i.e., altering its internal impedance to produce a matched load in response to variations in these factors. The TEG versions are linked via a DC-to-DC converter, which allows them to optimize power for current as well as voltage at all times. The voltage that is produced from DC-to-DC converters is tried to be adjusted to high or low values.

4. **Acoustic Energy Harvesting:** A continuous acoustic wave is converted into energy using an acoustic transducer in this procedure. When an electrical connection isn't possible, this helps immensely. In general, the density of accessible acoustic energy is low, and it is collected in noisy environments. In comparison to all previous EH approaches [17-20], the acoustic transducer's collected power is very low in density, and the supplied dc voltage is quite low.

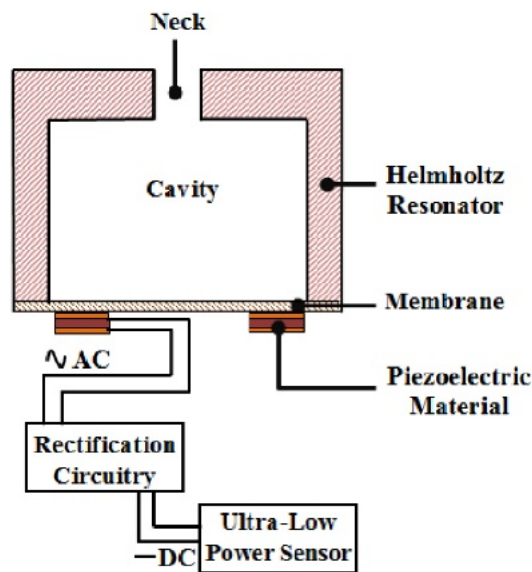

Figure 4: Block Diagram of an Acoustic Energy Harvesting System [20].

Acoustic energy harvesting (AEH) can transform acoustic energy into electricity. The energy conversion process, such as a permanent magnet or a piezoelectric membrane and a coil, is combined with a quarter-wavelength resonator or a Helmholtz resonator in an AEH. The use of acoustic resonators for noise reduction and sound enhancement is widespread [21]. The primary objective of the acoustic resonator in AEHs is to magnify the incident acoustic energy. As seen in Figure 4, the Helmholtz resonator has a neck and a hollow. The air in the resonator's neck behaves like a lumped mass, but the air trapped inside the cavity acts like a spring, holding the air in the neck in place. The air moving in the Helmholtz resonator is dampened by the narrower neck part. The lumped air at the neck is oscillated by the incident acoustic pressure wave. The pressure of the air inside the cavity rises as the air in the neck moves lower; conversely, the pressure of air in the

cavity falls as the air moves upward. In the cavity, the pressure amplitude is always greater than that of the incident acoustic wave. The pressure in the fluctuating cavity activates the energy transduction process, which generates power.

5. Radio Frequency Energy Harvesting (RFEH): Radio frequency energies present in the environment are captured and transformed into electrical energy using this technology. The accessible density of electromagnetic energies in the surrounding air is relatively low, and the energy is continuous regardless of seasonal and diurnal changes. The key benefit of this energy harvesting technology is that it can be used effectively in an indoor atmosphere. The harvesting system takes up a tiny amount of space in terms of size. A rectenna or rectifying device is a unique device that is used to capture RF energy [2-4, 22-25].

6. Wind Energy Harvesting (RFEH): The output energy provided in this system is determined by environmental factors in this method. Because it is highly uncertain, the output power is limited, and the conversion efficiency is low [2-3, 26-28].

7. Comparison of Various Energy Harvesting Approaches

Table 1: Comparison of Various Energy Harvesting Systems [3-4, 29]

Energy Harvesting Approach	Input Power Density (W/cm ²)	Output Power Density	Efficiency (%)	Availability
Photo-voltaic	Outdoor: 100 m Indoor: 0.1 m	Outdoor: 15 mW/cm ² Indoor: 10-100 μW/cm ²	Until 40	Light Dependent
Piezoelectric Vibration	10-200 μ	4-100 μW/cm ³	Until 30	Movement Dependent
Thermoelectric	Human: 100 μ Industrial: 100 m	Human: 30 μW/cm ² Industrial: 10 mW/cm ²	10-15	Temperature-gradient Dependent
Radio Frequency	0.1-1000 μ	0.1 μW/cm ²	50-70	Continuous
Acoustic	-	1.436 mW/cm ²	0.012	Not-continuous
Wind	28.5 m	-	0.61-17.6	Wind Dependent

III.ROLE OF RF ENERGY HARVESTING SYSTEM

The increased use of various portable and handheld gadgets, among other things, has risen in recent days as a result of the expanded use of wireless technology. As a result, more RF power radiators, such as wireless communication systems, cellular towers, Wi-Fi hubs, FM radio stations, digital television (DTV) towers, and have been developed to meet people's demands. The power density in the surrounding atmosphere is increased with the increasing

number of radio transmitters. Because of the rising power density, compactness, and ability to operate RF energy harvesting systems efficiently within indoor and outdoor environments, RF energy harvesting technology has inspired the world over other EH systems. Microwave signals in the ambient environment are very low in density when compared to solar and wind energies, but RF signals are always present. In applications where size reduction is critical, the RFEH approach can allow for size reduction in the harvesting system (relative to wind turbines and solar cells). As a result, RFEH could have been a superior choice for delivering a sustainable energy source in the face of forthcoming challenges.

The power conversion efficiency (PCE) of RF energy harvesting is the highest compared to all other EH techniques due to its continuous source of energy. Furthermore, advances made in wireless power transmission (WPT) systems that enable mobile electronic devices, microsensors, passive radio-frequency identification (RFID) systems, and wireless implantable devices to operate without the use of batteries have sparked interest in RF energy harvesting (RFEH). The RFEH may use wireless communication technologies to power batteries or electronic equipment, which is especially useful in remote places where access is limited or battery replacement is problematic (e.g. aircraft, chemical implants, bridges, etc). Harvesting RF energy also has the advantage of reaching inside building materials.

The RFEH method harvests electromagnetic energy from ubiquitous or specific RF sources in the atmosphere around it and processes the signal to power low-power gadgets. The power density is accessible from various RF sources ranging from 0.1 W/cm² (ambient source) to 1000 W/cm² (specialized source). A rectifying antenna, which consists of a constructed antenna and rectifier circuit, is used to capture the EM signal. This rectifying antenna, also known as a rectenna, has gotten a lot of interest from scientists in recent years.

IV. BLOCK DIAGRAM OF THE RADIO FREQUENCY ENERGY HARVESTING

Figure 1.5 depicts the fundamental block layout of a rectenna system. The rectenna system is made up of an antenna, a rectifier, an impedance-matching network, and an RF filter. The antenna detects and receives RF radiation, which is subsequently converted into a DC signal by the rectifier. An RF input filter, sometimes known as a "pre-rectifier," is a filter designed to suppress harmonics created by the rectifier's nonlinear component. For the greatest power transfer, a matching network must be connected between the filter and the rectifiers. The basic operation of a rectenna system is the same regardless of its purpose. Figure 1.6 is a flow diagram depicting several components and applications of the rectenna system.

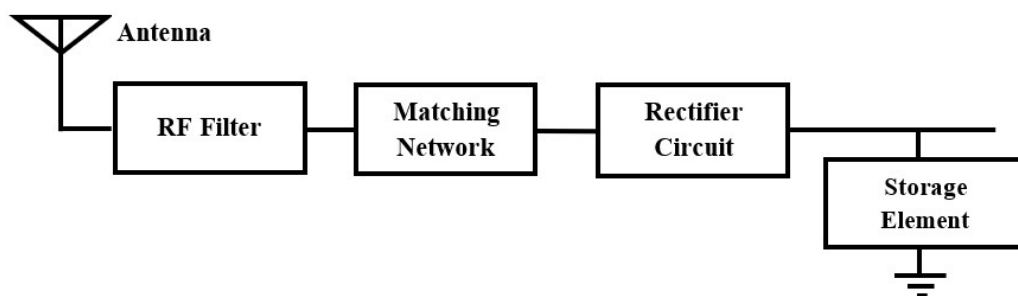

Figure 5: Block diagram of a Rectenna System [28].

RF energy sources include Global Positioning System (GPS), Worldwide Interoperability for Microwave Access (Wi-Max), frequency modulation (FM), Universal Mobile Telecommunications System (UMTS), digital television (DTV), Global System for Mobile Communications (GSM), Wireless Fidelity (Wi-Fi), Long Term Evolution (LTE), and 5G, among others. RFEH systems can benefit through the energy from various sources. Table 1.2 displays the frequency bands of several of the sources.

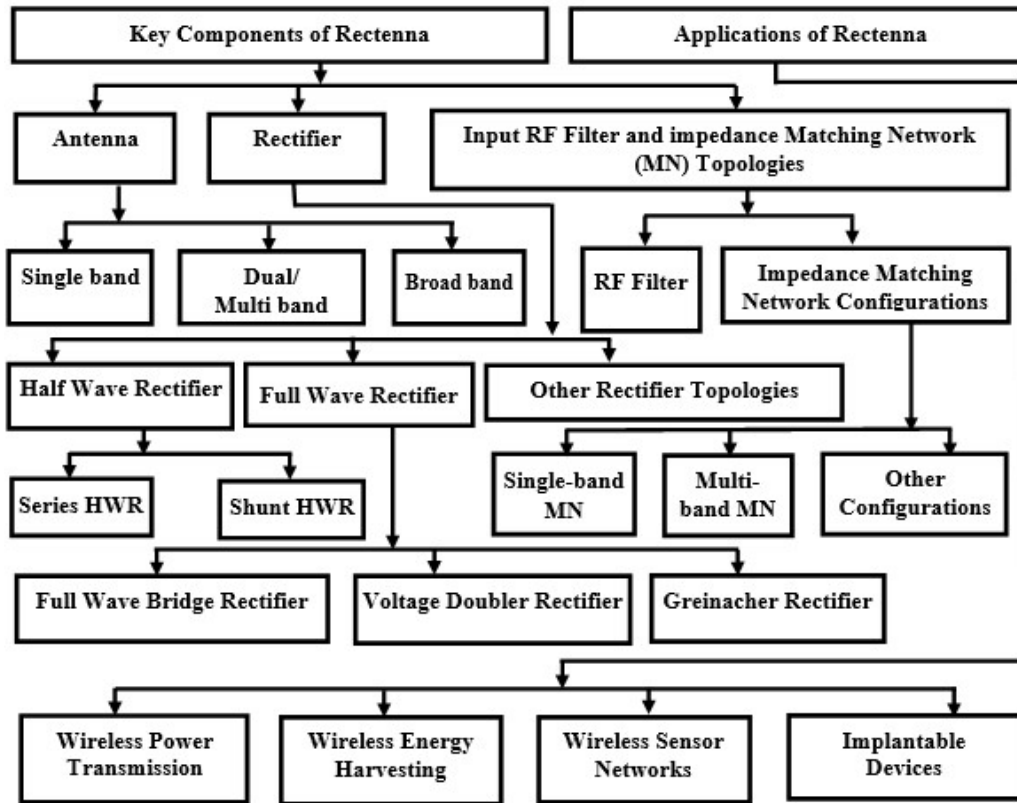

Figure 6: Flow Diagram of Various Components of the Rectenna System [20].

Table 2: Frequency Bands and Ranges

S. No.	Frequency Band	Range of Frequencies (MHz)
1.	AM	0.550-1.650
2.	ISM	13.553-13.567
3.		26.957-27283
4.		40.66-40.70
5.		433.05-434.79
6.		2400-2480
7.		5728-5870
8.		24000-24250
9.		DTV
10.	FM	88-108
11.	LTE800	824-894
12.	GSM900	890-960

13.	GSM-L1	1563-1587
14.	GSM1800	1710-1880
15.	UMTS2100	1920-2170
16.	LTE2300	2300-2400
17.	LTE2500	2500-2690
18.	5G	3300-3600
		3700-4200
		4800-4990
		24250-29500
19.	Wi-Fi 6	5925-7125
20.	WLAN5.2	5175-5735

V. EVOLUTION OF THE RECTENNA SYSTEM

In the 1950s, Raytheon company presented an airborne microwave platform concept to deliver a microwave beam at a height of 50000 ft. The experimental measurement setup of the rectenna for microwave power model helicopter applications is presented in Figure 1.7. In the 1960s, the concept of the rectenna was initially proposed by William C. Brown of Raytheon Company for WPT applications [30]. At that time, Brown was facing problems with how efficiently to receive microwave signals and convert them into electrical DC power. Brown was having difficulty in finding a suitable diode in the rectifier circuit for converting the microwave beam into DC at the time, although he had successfully developed a rectenna in 1964 and patented it in 1969 by William C. Brown [31]. Brown conducted some experiments, and in the end, he built a model helicopter that flew at a height of 30 feet from his lawn and was driven by a microwave power beam [32]. The helicopter, which was powered by a microwave power beam of a few hundred watts, utilized an array of rectenna elements. For delivering adequate power to the helicopter, a 5 KWatt microwave generator, such as a magnetron, was used. The rectenna was extremely huge at the time of its manufacture. Since the rectenna's development, significant research has been conducted to enhance rectenna efficiency by reducing size.

VI. RECTENNA FOR WIRELESS POWER TRANSMISSION (WPT)

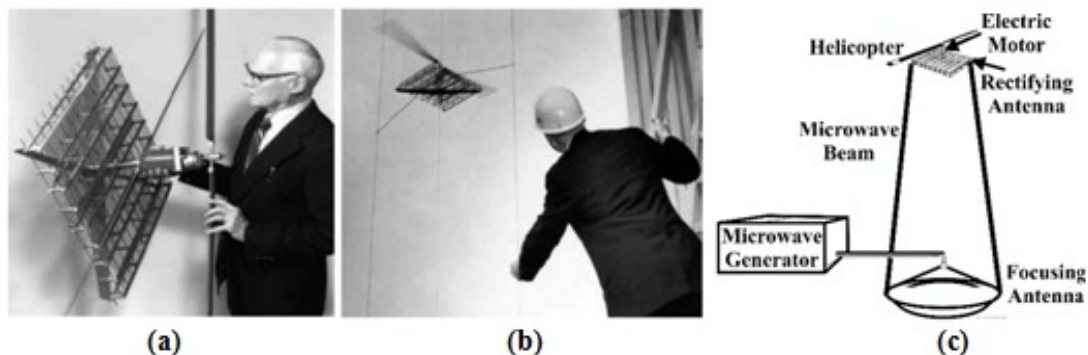

Figure 7: (a) Close-up view of the Microwave-Powered Helicopter, (b) View of the Helicopter in Flight at an Altitude of 30 ft [32], (c) Basic Design Elements of the Microwave-Powered Helicopter [33].

The WPT concept had begun with the findings of Heinrich Hertz and the experimental demonstrations of Nikola Tesla's transmission of radio waves in the 1890s [21, 23, 25, 31-35]. Heinrich Hertz used Maxwell's equations to verify the existence of electromagnetic waves for the first time in an experiment. Nikola Tesla expanded on Hertz's research on power transmission via radio waves. Tesla was explored experimentally by employing two magnetic coils positioned in space with no physical media between them, and he was able to efficiently transfer the microwave beam from one magnetic coil to the second coil. Tesla, on the other hand, never found a commercially viable outlet through his presentation. Tesla's work sparked the academics' curiosity in using microwaves to efficiently transmit microwave beams across the wireless medium. Wireless transmission can help power electrical gadgets when joining lines are difficult, dangerous, or not practicable. A strongly focused microwave beam was found as being necessary for the 1930s, and this beam is employed for directing onto small antennas. However, this could not be successfully applied until a suitable microwave generator, such as a magnetron, was designed to generate a significant amount of microwave power signals.

The microwave-powered aircraft is made up of various parts. A microwave generator, such as a Magnetron, was utilized to provide enough power for the helicopter in the form of a microwave beam that was transmitted through a microwave antenna, often a parabolic reflector antenna. Rectennas were installed on the helicopter to collect the transmitted microwave beam, which performed satisfactorily [33, 36]. Rectenna applications are further developed for wireless sensor networks (WSN), wireless energy harvesting (WEH), and implanted devices. Rectennas, on the other hand, have greater size and low rectenna efficiency.

Various Approaches of WPT: The various approaches of WPT are the near-field approach of WPT and the far-field approach of WPT. Near-field transmission is usually performed either by inductive or capacitive coupling, whereas far-field transmission is performed by electromagnetic antennas. Microwave power transmission is a method of far-field coupling.

- 1. Near-Field Approach:** In the near field or non-radiative techniques, magnetic fields using inductive interactions within coils of wire or electric fields utilizing capacitive connections among electrodes made of metal are employed to transfer power over short distances. Inductive coupling is the most widely used wireless communication technology, and it is used to charge portable devices like phones, induction cooking, electric toothbrushes, portable wireless charging, and RFID tags or uninterrupted wireless power transfer in implantable medical devices like artificial cardiac pacemakers or electric vehicles.
- 2. Far-Field Approach:** Microwave power transfer is a radiative (far-field) technique. This method of wireless power transmission uses radio waves to transport energy, with the wavelength of the radio wave being reduced to that of a microwave. WPT's components include a receiver and transmitter antenna, as well as a generator. It's important to notice that the transmitter and reception antennas are not magnetically coupled. Because the transmitter and reception antennas are magnetically isolated in this form of WPT system, variations in impedance between the transmitting and receiving antennas are ignored, whereas magnetic resonance coupling and magnetic inductive take impedance into account. The disadvantages of this system include the high power transferred in WPT,

which is harmful to human health, the system's low efficiency, and its restriction to only straight-line propagation.

VII. RECTENNA FOR SOLAR POWER TRANSMISSION (SPT)

Rectenna usage can also be found in solar power transmission (SPT) applications. Various conversion mechanisms are used in this system to make use of the vast amount of solar energy that is accessible. Figure 1.8 shows the SPT system arrangement, where photovoltaic (PV) cells are installed on the satellite system to collect solar energy, which is subsequently converted to dc electricity. Solar energy cannot be directly transformed into microwave energy. As a result, microwave generators such as magnetrons are used to convert dc power into microwave energy, and this transformed microwave energy is transmitted to the ground station. To capture such a vast amount of microwave power, a large rectenna system is installed on the ground plane, where the rectenna system has roughly 13 billion antenna elements and seven billion rectifier elements occupying an area of 10 kilometers in diameter. At a frequency of 2.45 GHz, the rectenna receives 5GW of microwave power with a maximum power density of 24.3 mW/cm². This is the greatest power density that a single solar satellite can send from space. Nonlinear heating of the ionospheric layer is possible beyond this limit [37].

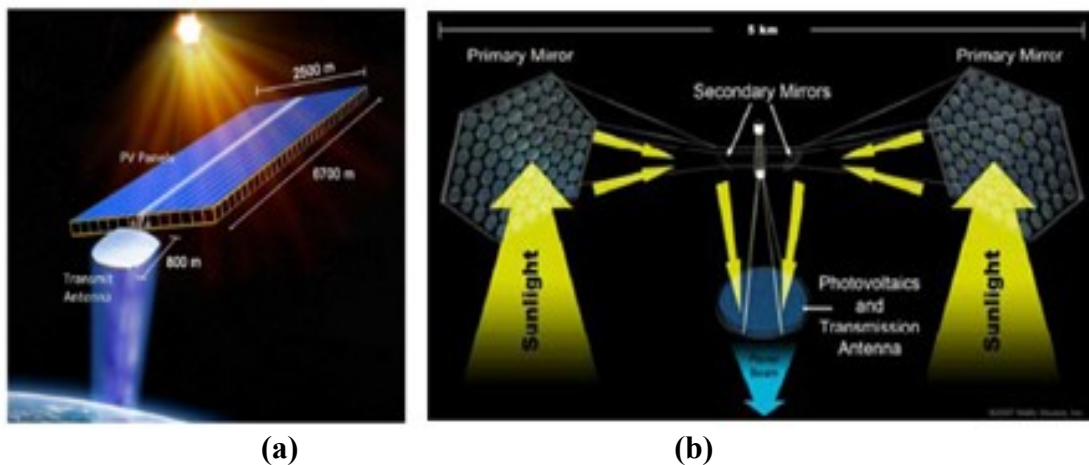

Figure 8: (a) Solar Power Satellite System [9], [b] Photovoltaic Cells [9].

By simply increasing the radiating power of the space-based microwave generators, the capturing power at the ground-based rectenna system cannot be enhanced. This can be accomplished by increasing the number of solar satellite systems, as depicted in Figure 1.9. This prevents the maximum permitted power density level from being exceeded [38].

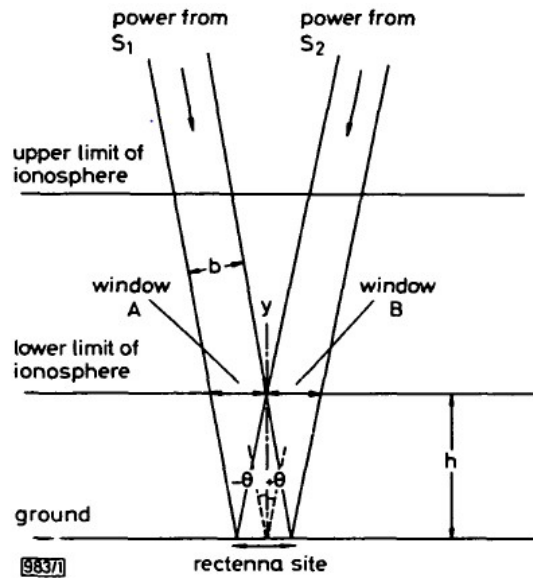

Figure 9: The Arrangement of Two Solar Satellites Feeds a Single Rectenna System [38].

VIII. REAL-TIME APPLICATIONS

1. Short-Range Applications

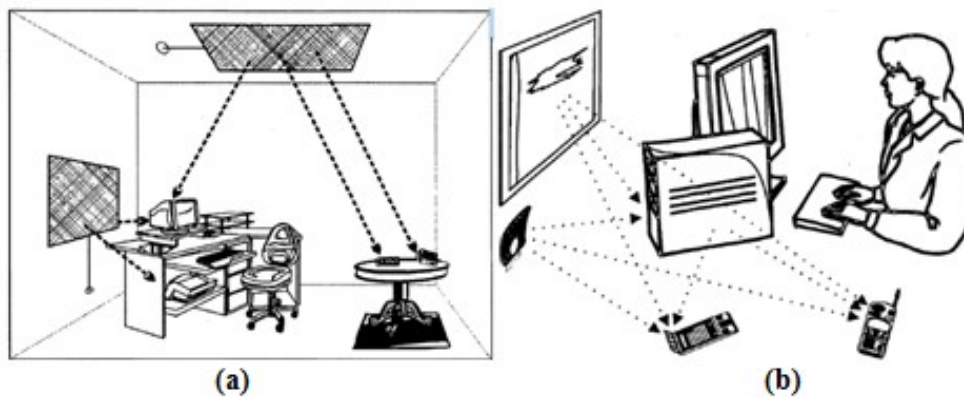

Figure 10: (a) Ceiling and Wall-Mounted Power Transmission Units (PTUs) in the Home or Office Environment, (b) Devices with PRUs Receiving Energy from a PTU and Ambient EM Radiation [39].

WPT is also used in short-range applications like transmitting electrical utility power to various gadgets in the home and business, as presented in Figure 1.10. A power transmission unit (PTU) generates a radiation beam with the use of electricity and is connected to the electrical grid. A power receiving unit (PRU) is built within the device, and it receives RF energy from one or more PTUs before converting it to electricity. Finally, the electrical energy is delivered to appliances using PRUs or a battery. Because each device requires the connection of one or more PRUs to receive adequate power, this strategy is not appropriate from a design standpoint. Furthermore, the range of power

transmission can be expanded by adding additional relay units, although this adds to the design complexity and costs [39].

2. **Sensing Applications:** Sensors are the most important components of a wireless sensor network (WSN). Sensors require a constant power supply to perform properly. Sensors often run at low power levels, which can be provided by an internal battery. Because conventional batteries have a limited lifespan, RF energy harvesting is the best option due to its availability at all hours of the day and night. A rectenna can be used to extend the battery's life. Figure 1.11 shows the usual power requirements for some commonly used handheld and portable devices.



Figure 11: Power Requirement of some Portable Devices [40].

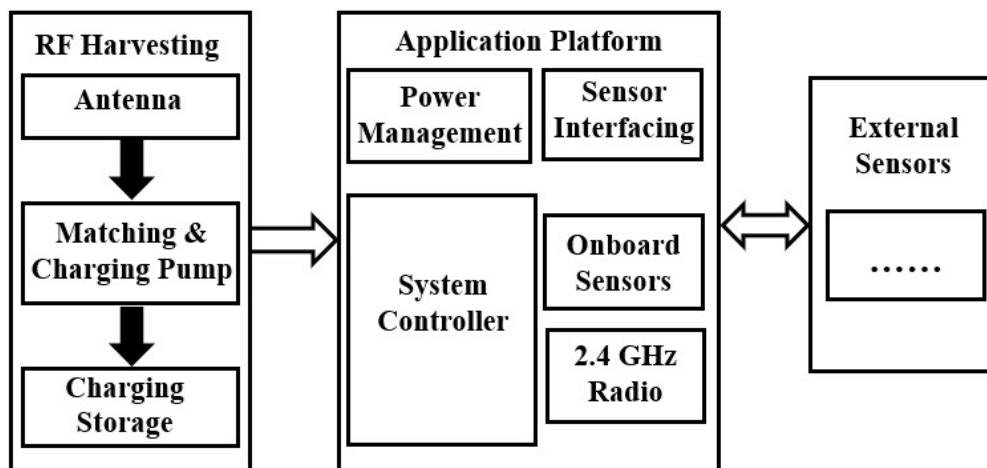

Figure 12: Sensor Node Architecture Powered by RF Energy Harvesting Technique [41]

A sensor node's architecture is seen in Figure 12. An RF energy harvesting circuit with a charge-storing device is included in the first segment. The application-based work of data sensing and transmission is discussed in the second section. The application platform area also includes several sensors and battery management systems. Externally, several sensors are also integrated with the system.

Table 3: Comparison of Various Characteristics of Active and Passive RFID Technologies

Characteristic Parameters	Passive RFID	Active RFID
Tag battery	Not required	Required
Tag Power Source	External (from the reader via radio frequency)	Internal (from the battery)
Signal strength available from the tag to the reader	Small	Large
Signal strength required from the reader to tag	Large	Small
Tag power availability	Only with the field of a reader	Continuous
Multi-tag collection	Connects hundreds of tags from a single reader	Connects thousands of tags from a single reader
Sensor capability	Monitor and transfers only when the tag is powered by a reader	Continuously monitor and record the data
Range of communication	Short-range (limited to 3m)	Long-range (100m or more)
Data storage	Small read/write data storage (almost 128 B)	Large read/write data storage (almost 128 kb)

Radiofrequency identification (RFID) tags for tracking items at shopping malls are examples of RFEH uses. RFID tags have become increasingly popular in tracking systems in recent years. Active RFID tags and passive RFID tags are the two types of RFID tags utilized. The following Table 3 lists the characteristics of these two approaches.

By underground sensor networks connected with a rectenna system, energy harvesting techniques are also used to monitor the health of construction bridges. A stacked microstrip patch antenna operating at 5.7 GHz is designed to gather EM energy in this paper. For conversion, a single-diode half-wave rectifier is utilized. The rectenna's performance is noticeable in both dry and wet concrete, and the decrease in performance is noticeable as the cover thickness increases. Dry concrete outperforms wet concrete in terms of rectenna performance [42]. Figure 13 depicts the underground concrete harvesting mechanism.

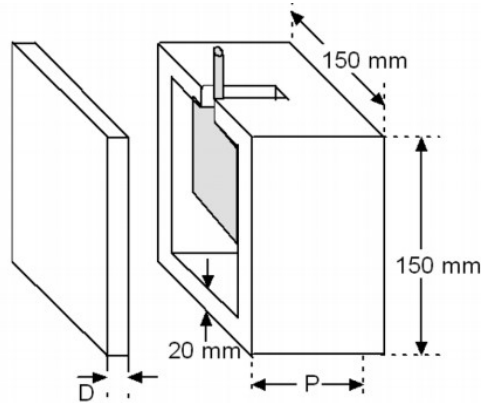

Figure 13: Rectenna System Embedded in Buried Concrete [42].

A rectenna is also implemented to activate the end device radio nodes of a wireless sensor network. A Vivaldi antenna is designed for receiving RF energy from ambient sources [43].

Most people are concerned about their health these days. Many people are suffering from numerous health problems as a result of the contaminated environment and harmful food. Implantable devices are worn by certain persons to monitor the health of several organs continuously. These implantable devices must be delivered with sufficient power continually to offer uninterrupted monitoring. Energy harvesting techniques are becoming more attractive for combining with implantable devices due to the disadvantages of traditional batteries. The RFEH technology, in particular, is widely used because of its more adaptable features than other energy harvesting technologies.

The performance of the RFEH system is tested by embedding a rectenna system in the minced pork front leg [44]. In [45], a rectenna system is used to control a deep-brain stimulation (DBS) device that may be worn on the head. DBS is an effective therapy for psychological and neurological diseases. RFEH's applications in power transmission to deep-body implanted devices are also investigated in [46]. A rectenna application was also investigated to track a person's temperature by integrating the rectenna with a sensor placed in a wearable textile material [47].

IX. CONCLUSION

The rapid growth in wireless technology involves different applications such as the internet of thing-based smart cities. In smart cities, several user-friendly applications are performed. For uninterrupted services, a continuous source of energy is to be provided, which is possible by energy harvesting approaches. The radiofrequency energy harvesting approach has found a suitable technique due to its unique features of increasing availability, large PCE, compactness, and ability to operate indoor and outdoor environments. Besides, the prospects of the RFEH approach for smart cities are expected to play a significant role in providing sufficient batteries to portable/wearable consumer electronics devices.

This chapter aims to provide sufficient information to a researcher in designing a suitable rectenna (or rectifying antenna) system to generate useful electrical power by

harvesting very low-density RF signals which are freely available in the atmosphere. Although considerable advances in rectenna designs have been achieved, the vast majority of the published works are dedicated to maximizing the system efficiency at often high input power levels. Only a few attempts on compact rectenna systems have been reported, however, the achieved gain and power conversion efficiencies (PCE) are low. Therefore, the aim of the current research comes with the agenda of designing compact rectenna systems with a high gain and large conversion efficiency using the combination of dielectric resonator antennas and various rectifier topologies.

REFERENCES

- [1] G. Monti, et al., "Monopole-based rectenna for microwave energy harvesting of UHF RFID systems", *PERC*, vol. 31, 109-121, 2012.
- [2] J. A. Paradiso and T. Starner, "Energy scavenging for mobile and wireless electronics," *IEEE Pervasive Computing*, Vol. 4, no. 1, pp. 18-27, Jan. 2005.
- [3] R. J. M. Vullers, R. V. Schaijk, I. Doms, C. Van Hoof, and R. Mertens, "Micropower energy harvesting," *Solid-State Electronics*, vol. 53, pp. 684-693, 2009.
- [4] S. Kim, R. Vyas, J. Bito, K. Niotaki, A. Collado, A. Georgiadis, and M. M. Tentzeris, "Ambient RF energy-harvesting technologies for self-sustainable standalone wireless sensor platforms," *Proceedings of the IEEE*, vol. 102, pp. 1649-1666, 2014.
- [5] H. S. Kim, J.- H. Kim, and J. Kim, "A review of piezoelectric energy harvesting based on vibration," *International Journal of Precision Engineering and Manufacturing*, vol. 12, no.6, pp.1129-1141, Dec. 2011.
- [6] A. Nechibvute, A. Chawanda, and P. Luhanga, "Piezoelectric Energy Harvesting Devices: An Alternative Energy Source for Wireless Sensors", *Smart Materials Research*, Vol. 2012, Article ID 853481, 13 pages, 2012.
- [7] P. Jaffe and J. McSpadden, "Energy conversion and transmission modules for space solar power," *Proceedings of the IEEE*, vol. 101, pp. 1424-1437, 2013.
- [8] V. Raghunathan, A. Kansal, J. Hsu, J. Friedman, and M. Srivastava, "Design considerations for solar energy harvesting wireless embedded systems," *IPSN'05 Proceedings of the 4th international symposium on information processing in sensor networks*, Article No. 64, pp. 457-462.
- [9] M. A. Green, K. Emery, Y. Hishikawa, W. Warta, and E. D. Dunlop, "Solar cell efficiency tables (Version 38)," *Progress in Photovoltaics: Research and Applications*, vol. 19, pp. 565-572, 2011.
- [10] S. H. Krishnan, D. Ezhilarasi, G. Uma, and M. Umapathy, "Pyroelectric-based solar and wind energy harvesting system," *Sustainable Energy, IEEE Trans. on Sustainable Energy*, Vol. 5, no. 1, pp. 73-81, 2014.
- [11] D. Antolin, N. Medrano, B. Calvo and P.A. Martinez, "A Compact Energy Harvesting System for Outdoor Wireless Sensor Nodes Based on a Low-Cost in Situ Photovoltaic Panel Characterization-Modelling Unit," *Sensors*, Vol. 17, no. 1794, pp. 1-18, 2017.
- [12] L. Long and H. Ye, "How to be smart and energy efficient: A general discussion on thermochromic windows," *Scientific Reports*, vol. 4, no.6427, pp. 1-10, 2014.
- [13] H. Lhermet, C. Condemine, M. Plissonnier, R. Salot, P. Audebert, and M. Rosset, "Efficient Power Management Circuit: From Thermal Energy Harvesting to Above-IC Microbattery Energy Storage," *IEEE Journal of Solid-State Circuits*, Vol. 43, no. 1, pp. 246-255, Jan. 2008.
- [14] Y. Du, K. Cai, S. Chen, H. Wang, S. Z. Shen, R. Donelson, and T. Lin, "Thermoelectric Fabrics: Toward Power Generating Clothing," *Scientific Reports*, Vol. 5, no.6411, 2015.
- [15] S. B. Inayat, K. R. Rader, and M. M. Hussain, "Nano-materials Enabled Thermoelectricity from Window Glasses," *Scientific Reports*, vol. 2, no. 841, Nov. 2012.
- [16] K. Yahya, M. Salem, N. Iqteit and S.A. Khan, "A Thermoelectric Energy Harvesting System. Renewable Energy - Resources, Challenges and Applications", *Renewable Energy-Resources, Challenges and Applications*, pp. 1-18, 2020.
- [17] D. Jang, J. Jeon, and S. K. Chung. "Acoustic Energy Harvester Utilizing a Miniature Rotor Actuated by Acoustically Oscillating Bubbles-Induced Synthetic Jets", 2017 IEEE 30th International Conference on Micro Electro Mechanical Systems (MEMS), pp. 41-44, Jan. 2017.
- [18] H. Basaeri, Y. Yu, D. Young, and S. Roundy. "A MEMS-Scale Ultrasonic Power Receiver for Biomedical Implants", *IEEE Sensors Letters*, Vol. 3, No.4, pp. 1-4, Apr. 2019.

- [19] B. Li, and J. H. You, "Harvesting ambient acoustic energy using acoustic resonators", Proceedings of Meetings on Acoustics, Vol. 12, no. 65001, pp. 1-8, 2011.
- [20] F.U. Khan and Izhar, "State of the art in acoustic energy harvesting ", Journal of Micromechanics and Microengineering, Vol. 25, no. 23001, pp. 13, 2015.
- [21] W. Lumpkins, "Nikola Tesla's Dream Realized: Wireless power energy harvesting," IEEE Consumer Electronics Magazine, Vol. 3, pp. 39-42, Jan. 2014.
- [22] A. Costanzo, M. Dionigi, D. Masotti, M. Mongiardo, G. Monti, L. Tarricone, and R. Sorrentino, "Electromagnetic Energy Harvesting and Wireless Power Transmission: A Unified Approach", Proceedings of the IEEE | Vol. 102, No. 11, pp. 1692-1711, Nov. 2014.
- [23] W. C. Brown, "The history of power transmission by radio waves," IEEE Transactions on Microwave Theory and Techniques, Vol. MTT-32, no. 9, pp. 1230-1242, Sep. 1984.
- [24] W. C. Brown, "Experiments Involving a Microwave Beam to Power and Position a Helicopter", IEEE Transactions on Aerospace and Electronic Systems, Vol. AES-5, no. 5, pp. 692-703, Sept. 1969.
- [25] N. Shinohara, "Power without wires," IEEE Microwave Magazine, vol. 12, pp. S64-S73, 2011.
- [26] T.L. Chern, P.- L. Pan, Y.- L. Chern, W.- T. Chern, W.- M. Lin, C.- C. Cheng, J.- H. Chou, and L.- C. Chen, "Excitation synchronous wind power generators with maximum power tracking scheme," IEEE Transactions on Sustainable Energy, Vol. 5, no.4, pp. 1090-1098, Oct. 2014.
- [27] F. Kong, C. Dong, X. Liu, and H. Zeng, "Quantity Versus Quality: Optimal Harvesting Wind Power for the Smart Grid," Proceedings of the IEEE, Vol. 102, no.11, pp. 1762-1776, 2014.
- [28] S. Nabavi, L. Zhang, "Portable Wind Energy Harvesters for Low-Power Applications: A Survey", *Sensors*, 16, 1101, pp. 1-31, 2016.
- [29] H.H. Ibrahim, M.S.J. Singh, S.S. Al-Bawri and M.T. Islam, "Synthesis, Characterization and Development of Energy Harvesting Techniques Incorporated with Antennas: A Review Study", *Sensors*, 20, 2772, pp. 1-27, 2020.
- [30] W. C. Brown, "The Microwave Powered Helicopter", *J. Microw. Power*, Vol. 1, no. 1, pp. 1-20, Jun. 2016.
- [31] W.C. Brown et al, "Microwave to dc converter," US Patent US3434678A, filed 05 May 1965 and issued 25 March 1969.
- [32] W. C. Brown, "The Microwave Powered Helicopter", *Journal of Microwave Power*, vol. 1, no.1, pp. 1-20, Jun. 2016.
- [33] W. C. Brown, J. R. Mims, N. I. Heenan, "An Experimental Microwave -Powered Helicopter", 1958 IRE International Convention Record, pp. 225-236, Mar. 1966.
- [34] N. Tesla, "Experiments with alternate currents of high potential and high frequency", A lecture, McGraw-Hill, 1904.
- [35] J. L. W. Li, "Wireless power transmission: State-of-the-arts in technologies and potential applications (invited paper)," *Asia-Pacific Microwave Conference 2011*, pp. 86-89, Dec. 2011.
- [36] W. C. Brown, J. F. Skowrong, H. Macmaster and J. W. Buckley, "The Super Power CW Amplitron", 1963 International Electron Devices Meeting, Nov. 1963.
- [37] R. Andryczyk, P. Foldes, J. Chestek, and B. M. Kaupang, "Solar power satellite ground stations: The ground systems for microwave beaming from the SPS would require a rectifying antenna with over 13 billion elements", *IEEE Spectrum*, pp. 51-55, Jul. 1979.
- [38] R. V. Gelsthorpe, P. Q. Collins, "Increasing Power Input to a Single Solar Power Satellite Rectenna by using A Pair of Satellites", *Electronics Letters*, Vol. 16 No. 9, pp. 311-313, Apr. 1980.
- [39] E. Vecchione et al. "Short-Range Wireless Power Transmission and Reception", US 2006/0238365A1, pp. 1-10, Oct. 2006.
- [40] R. J.M. Vullers, R. V. Schaijk, H. J. Visser, J. Penders, and C. V. Hoof, "Energy Harvesting for Autonomous Wireless Sensor Networks", *IEEE Solid-State Circuits Magazine*, Spring2010, pp. 29-38, 2010.
- [41] G. Xu, W. Shen, and X. Wang, "Applications of Wireless Sensor Networks in Marine Environment Monitoring: A Survey", *Sensors*, Vol. 14, 16932-16954, 2014.
- [42] K. M. Z. Shams, and Mohammad Ali, "Wireless Power Transmission to a Buried Sensor in Concrete", *IEEE Sensors Journal*, Vol. 7, No. 12, pp. 1573-1575, Dec. 2007.
- [43] F. Congedo, G. Monti, L. Tarricone, and V. Bella, "A 2.45-GHz Vivaldi Rectenna for the Remote Activation of an End Device Radio Node", *IEEE Sensors Journal*, Vol. 13, No. 9, pp. 3454-3461, Sept. 2013.
- [44] F.J. Huang, C.- M. Lee, C.- L. Chang, L.- K. Chen, T.- C. Yo, and C.- H. Luo, "Rectenna Application of Miniaturized Implantable Antenna Design for Triple-Band Biotelemetry Communication", *IEEE Transactions on Antennas and Propagation*, Vol. 59, No. 7, pp. 2646-2653, Jul. 2011.

- [45] M.K. Hosain, A. Z. Kouzani, MST F. Samad, and S. J. Tye, “A Miniature Energy Harvesting Rectenna for Operating a Head-Mountable Deep Brain Stimulation Device”, IEEE Access, Vol.3, pp. 223-234, 2015.
- [46] A. Abdi and H. Aliakbarian, “A Miniaturized UHF-Band Rectenna for Power Transmission to Deep-Body Implantable Devices”, Cardiovascular Devices and Systems, IEEE Journal of Translational Engineering in Health and Medicine, Vol.7, Mar. 2019.
- [47] G. Monti, L. Corchia, and L. Tarricone, “UHF Wearable Rectenna on Textile Materials”, IEEE Transactions on Antennas and Propagation, Vol. 61, No. 7, pp. 3869-3873, Jul. 2013.