

# SPECTROSCOPIC TECHNIQUES FOR IDENTIFICATION OF DRUGS IN DIFFERENT PHARMACEUTICAL PREPARATIONS

## Abstract

To precisely examine the chemical structure of an analyte, spectroscopic techniques are frequently used. Each technique allows the molecule to engage in interaction with the electromagnetic energy employed. The electric and magnetic properties of radiation interact with chemical substances that have similar properties. As a result, the analyte is recognised and described based on the presence of atoms, bonds, functional groups, basic nuclei, molecular formula, and molecular weight. The study is quite vital to have a reference that covers the majority of the significant analytical methods. The investigation includes information on the fundamentals of spectrum interpretation, rules and laws that must be followed, sampling methods, sample cells, measurement mechanisms, spectral ranges, light sources, types of samples to be analysed, types of used solvents, appearance of spectra, and important applications of individual spectroscopic analysis. These reflect qualitative and quantitative factors that are essential for the research and experiments conducted by the particular spectrum process, and they also encompass every key component of the numerous spectroscopic procedures. As a result, a study of the complete spectroscopic concept, apparatus, and applications will provide all analytical persons with useful information.

**Keywords:** Spectroscopic Analysis, UV Spectroscopy, Atomic Absorption Spectroscopy, Atomic emission

## Authors

### Swapnaja Bansilal Gunjarkar

Lecturer

Adv. V. R. Manohar Institute of Diploma in Pharmacy (Government Aided) Wanadongri, Hingna, Maharashtra, India. swapnjagunjarkar01@gmail.com

### Ankit Gajanan Kaikade

Adv. V. R. Manohar Institute of Diploma in Pharmacy (Government Aided) Wanadongri Hingna, Maharashtra, India.

### Juhi H. Rinke

Adv. V. R. Manohar Institute of Diploma in Pharmacy (Government Aided) Wanadongri Hingna, Maharashtra, India.

### Chetana M. Waghale

Adv. V. R. Manohar Institute of Diploma in Pharmacy (Government Aided) Wanadongri Hingna, Maharashtra, India.

### Shubham P. Bhute

Adv. V. R. Manohar Institute of Diploma in Pharmacy (Government Aided) Wanadongri, Hingna, Maharashtra, India.

### Nikhil D. Amnerkar

Adv. V. R. Manohar Institute of Diploma in Pharmacy (Government Aided) Wanadongri Hingna, Maharashtra, India.

SPECTROSCOPIC TECHNIQUES FOR IDENTIFICATION OF  
DRUGS IN DIFFERENT PHARMACEUTICAL PREPARATIONS

Spectroscopy, Fluorescence  
Spectroscopy, Infrared Spectroscopy,  
Nuclear Magnetic Resonance  
Spectroscopy, Mass Spectroscopy.

## I. INTRODUCTION

Spectroscopy is a branch of science that studies the interaction of electromagnetic radiation and matter. The most important aspect of this interaction is that matter absorbs or emits energy in the form of discrete particles called quanta. The mechanisms of absorption or emission are well understood across the electromagnetic spectrum, from the gamma region (nuclear resonance absorption or Mössbauer effect) to the radio region (nuclear magnetic resonance). When the frequency of the device is measured, it gives the value of the energy change from which the energy of the object can be determined and calculated. Spectroscopic science is the experimental measurement of the frequency of radiation (e.g. emission or absorption) and the reflection of energy from these measurements (Chatwal, G, 2002).

## II. UV SPECTROSCOPY

- 1. Introduction:** UV-Vis (ultraviolet visible) spectroscopy is often used to provide characterization information for many substances. UV-visible spectroscopy is used to identify organic or non-organic, material or liquid, such as organic molecules and functional groups, and also used in coating, dye, textile, biochemical analysis, separation kinetics, band gap measurement, etc. Can be used to measure parameters. . (J.L. Aldabi This, 2020).
- 2. Principle:** When electricity causes electrical changes in the structure of a molecule or ion, the substance will exhibit absorption in the visible or ultraviolet spectrum. Therefore, when the sample absorbs light in the visible or ultraviolet range, the electronic state of the molecules in the sample changes. Energy from light or anti-bonding orbitals moves electrons from the ground orbital state to a higher energy orbital state. (Verma, G. 2018).
- 3. Instrumentation (Figure 1)**

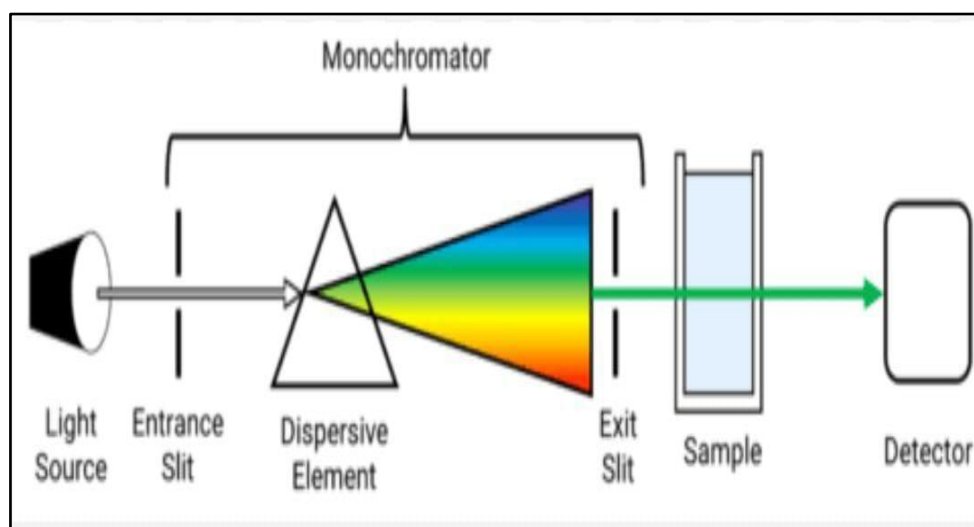

**Figure 1:** Instrumentation of UV- VIS Spectroscopy

The main components of the UV-visible spectrophotometer are as follows:

- Light (UV and visible light)
- Monochromator
- Sample box (cuvette)
- Detector
  
- **Light Source:** UV-visible spectrum requires a permanent light source or a light source that emits radiation in a certain wavelength range. The following are various sources of UV radiation:
  - **Hydrogen Lamp:** Between 160 and 380 nm, radiation from hydrogen lamps is consistently produced and is reliable. High-pressure hydrogen gas is what it is made of; this gas then discharges electricity. Radiation is produced by excited hydrogen atoms.
  - **Deuterium Lamp:** Deuterium lamp is a type of gas discharge lamp, mainly used as an ultraviolet lamp. It emits wavelengths ranging from 160 to 450 nm. It is more expensive than hydrogen batteries.
  - **Tungsten Lamp:** Tungsten lamp is the best type of light in spectrophotometer. It uses a tungsten filament sealed in a container and a visible spectrum of approximately 330 to 900 nm.
  - **Xenon Lamp:** Electric lamp containing xenon is called xenon lamp. The wavelength range of xenon radiation is between 250-600 nm.
  
- **Monochromator:** Monochromator produces monochromatic light by removing unwanted wavelengths from the light source. Multiwavelength polychromatic light enters the monochromator through the entrance slit. The beam is bent in the direction of the dispersion component after collimation. The grating or prism separates the wavelength of the light ray into its components. When the scattering element or slit is changed, only light of a certain wavelength is emitted from the monochromator through the slit.

Type of Monochromators:

- Prism Monochromator
- Grating Monochromator

Every Monochromator contains the following components:

- An entrance slit
- A collimating lens
- A dispersing device
- A focusing lens
- An exit slit

Polychromatic radiation, or radiation with more than one wavelength, enters the monochromator through the input line. After orientation, the beam is directed to

the scattering element. The grating or prism separates the wavelength of the light ray into its components. By changing the dispersion element or exit slit, only radiation of a certain wavelength passes through it to exit the monochromator.

- **Sample Containers (Cuvette):** The cuvettes are used for containing samples for various spectroscopic analysis. They are transparent for all wavelengths of light passing through them. The cuvette can be used for wavelengths from 190 to 200 nm, is square in shape, 1 cm long and made of quartz.
- **Detector:** The detector converts light energy into electrical pulses that are read on the reading device. When an electric current hits the sample, the device measures the amount of electricity the sample absorbs. Absorption spectrophotometer equipment uses the following testing equipment.

Types of Detectors:

- Barrier layer cell/Photovoltaic cell
- Phototubes/ Photo emissive tube
- Photomultiplier tube (Verma, G. 2018).

#### 4. Advantages

- The main advantage is the accuracy of UV-visible spectrophotometer
- The UV-VIS spectrometer is easy to use and operate
- Provide stable employment
- The UV-visible spectrophotometric method is easy to use
- Cost effective
- Covers all UV and visible light
- Can be used for both qualitative and quantitative measurements
- The derivative image can be obtained with a UV-visible spectrophotometer
- Can be used for chemical degradation research
- Only possible for the analytes which have a chromophore (M. Patil, 2018).

#### 5. Disadvantages

- Analysed only molecules containing chromophore
- Absorption can be affected by pH, temperature, bacteria and foreign substances.
- Only liquid samples can be analysed
- It will take time to be ready for use
- Cuvette holders can affect reading patterns (M. Patil, 2018).

#### 6. Applications: UV-visible spectroscopy has many applications,

- Impurity detection
- Analysis of the structure of organic compounds
- Many observations

- Quality assessment
- Drug test
- Quantitative analysis of drugs
- Dissociation constants for acids and bases
- Determination of molecular weight
- According to HPLC determination
- Deviation from the Beer-Lambert Law (Verma, G. 2018).

### III. ATOMIC ABSORPTION SPECTROSCOPY (AAS)

**1. Introduction:** Atomic absorption spectroscopy uses the absorption of optical energy (light) by carbon monoxide (CO) to determine various chemical concentrations. The basis of atomic absorption spectroscopy is the light absorption of free metal ions. This method is used in analytical chemistry to determine the concentration of a product (analyte) in a sample to be analyzed. AAS are used in chemical, biophysical, archaeological and toxicological research and can identify more than 70 different substances in solution or directly in samples via electrothermal evaporation (Paudel S, 2021).

**2. Principle:** This method uses the atomic absorption spectrum of the sample to determine the concentration of a particular element in it. The Beer-Lambert law is used to determine the relationship between absorbance testing and test concentration as it depends on the known pattern of test points (Paudel S, 2021).

#### 3. Types of AAS

- **Flame Atomic Absorption Spectroscopy (FAAS):** FAAS is often used to estimate the amount of metal in solution with parts per million (ppm) or parts per billion (ppb) accuracy. Metal ions were reduced to atoms and then selected by the special material by atomizing light from the hollow cathode lamp into the flame into a fine spray. The main disadvantages of this method are limited linearity, low sensitivity, and the ability to measure only one element at a time. Despite these problems, it has been found to be one of the best, most reliable methods for daily medication (Paudel S, 2021).
- **Graphite Furnace Atomic Absorption Spectroscopy (GFAAS):** GFAAS is a sensitive technique widely used to identify metals at low concentrations (less than 1 ppb) in small samples. Instead of using a flame, a narrow carbon is used to create the pattern, which increases sensitivity and detection is limited because there is no flame, ensuring most of the sample is atomized.

#### 4. Instrumentation (Figure 2)

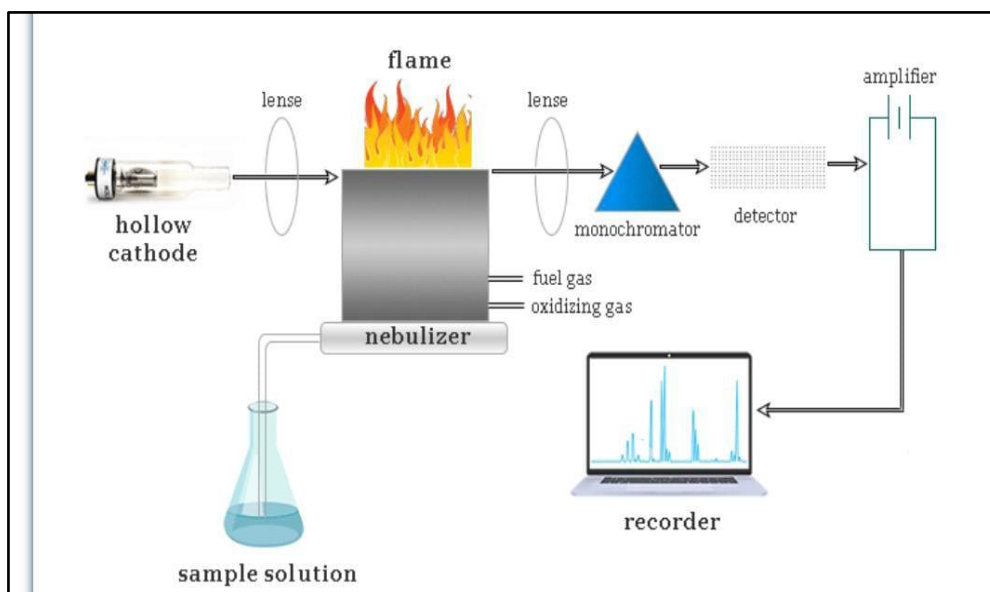

**Figure 2:** Instrumentation of Atomic Absorption Spectroscopy

- **Radiation Source:** Either a white light source with a double monochromator is utilised, or a hollow cathode discharge lamp, to provide a beam of radiation with a very narrow band width. The analysis of the element is done using discharge lamps. A tungsten anode and a metal cup cathode are holding a sample of the elements that need to be stimulated. To create an elemental spectrum, argon carrier gases are utilised at high voltage and low pressure.
  - **Nebuliser/Automiser:** Nebulizers are aroma spray devices where the sample is sprayed into the flame by forcing air through a capillary tube dipped in the sample solution.
  - **Flame:** Burners may be used in series to lengthen the sample's optical path.
  - **Monochromator:** The monochromator is used for tasks requiring higher resolution, but for direct ordinary analysis simple filters can be used in place of the monochromator.
  - **Capture:** A phototube or photomultiplier tube is usually used (Bodel S, 2021).
- 5. Advantage and Disadvantage of AAS:** The advantages include the economy of the machine, its relative ease of use, its sensitivity (allowing to determine a range in ppm and even lower), high precision and accuracy in calibration curves, and most importantly, the occurrence of metal atomic absorption. . In terms of good wavelength and limited bandwidth, it prevents isotopes of the same element from absorbing each other's wavelengths. One of the disadvantages of this method is that it is used less frequently, as there are only around 70 elements that are not earth metals. Another disadvantage of

atomic absorption spectrometry is that it cannot detect non-ferrous metals (Paudel S, 2021).

**6. Applications:** Atomic absorption spectrometry is widely used and important in identifying metals in samples. Therefore, this method is often used in the following situations:

- Pharmacology
- Archaeology
- Manufacturing
- Mining
- Forensic (Paudel S, 2021).

#### IV. ATOMIC EMISSION SPECTROSCOPY (AES)

**1. Introduction:** Atomic emission spectroscopy (AES) is a chemical analysis technique that measures the concentration of elements in a sample by measuring the intensity of specific wavelengths of light emitted by a flame, plasma, arc, or spark. When the intensity of the emitted light is related to the atoms in the element, the wavelength of the atomic line in the emission spectrum is used to identify the element (Y. Anithakumari, 2021).

**2. Principle:** AES works on the principle that when energy is transferred to a molecule in the form of light or heat, the molecule is excited and changes from a lower energy state to a higher state strength. Molecules are unstable in a high energy state and return to a lower energy state when they release energy in the form of photons. An emission spectrometer records the wavelength of the emitted photon. The energy difference between the excitation energy and the lower energy determines the emission level of the molecule. The emission frequency level emitted by each element determines its performance. Emission spectrometers display container emission frequencies (Y. Anithakumari, 2021).

#### 3. Instrumentation (Figure 3)

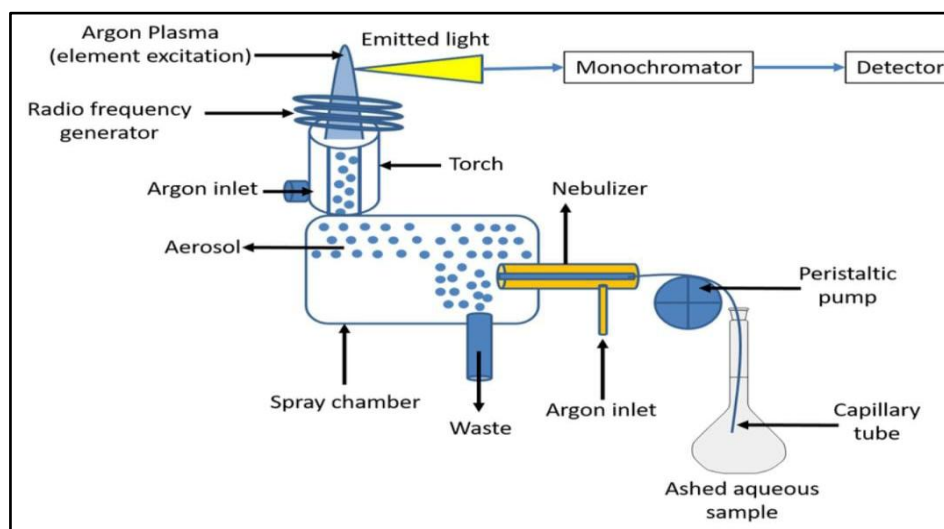

**Figure 3:** Instrumentation of Atomic Emission Spectroscopy



- **Sample Introduction:** The main steps in the AES analysis process are sample preparation and blood injection. Before analysis, the sample must be converted into very free atoms. An inert gas is injected to transport the liquid sample to the excitation source, usually argon at a flow rate of 0.3 to 1.5 L/min. Atomizing the liquid through an atomizer is the most effective way to add it to the water stream. For example, ultrasonic transducers can be used to create aerosols instead of high-pressure jets passing over the end of a narrow orifice. These droplet sizes have a significant impact on the stability of the spectrum emission. Therefore, choosing the right kind of nebulizer is essential for producing droplet sizes that are uniform. Sample properties such as density, viscosity, organic content, total explosives, and total sample volume determine the best nebulizer to use.
- **Excitation Sources:** The atoms of the sample are dissolved, atomized and excited using the excitation source. All elements in the model must be able to be excited, and the best source of stimulation should allow this to happen many times until all elements in the model are excited. Various excitation sources are used for this purpose.
- **Spectrometer:** Spectrometers of samples are used to analyze and measure many specific substances. Atoms or ions will be excited from a low energy state to a high energy stable state from an atomic emission source. Excited molecules or ions will return to a stable or low energy state on their own. During this change, photons of energy are produced that cause the emission spectrum. The number of molecules or ions present inside the sample is directly related to the energy output. A spectrometer can measure this energy by using optics to separate the signal wavelength from the background plasma. Because the structure of a multi-element structure can be very crowded, a high-resolution spectrometer is required to separate the spectrum of adjacent atomic transitions. Dispersion and image transmission constitute the spectrometer. Gratings are used as splitters in AES spectrometers to separates the light into its component wavelengths. The grating works by reflecting light from its curved surface, causing a reflection whose wavelength-dependent diffraction angle affects the wavelength. Since all atoms of different elements in the sample are excited simultaneously, they can be detected using a monochromator or simultaneously using a polychromator and multiple detectors. The images transmission of the spectrometer has a concave mirror or lens and input and output slits through which light is transmitted in a distinct line across the entire spectrum.
- **Detector:** Detectors are the sensors which converts the analog output of the spectrometer into an electrical signal that a computer can display and analyze. To measure the intensity of radiation, a photon detector either emits electrons or creates an electric current when photons hit the detector's surface. Examples include charge-coupled devices (CCDs), charge-coupled devices (CIDs), and photomultiplier tubes (PMTs). In inductively coupled plasma atomic emission spectroscopy (ICP-AES), PMT is the most widely used equipment. When exposed to light, the photocathode in the vacuum enclosure of the PMT detector releases electrons. These electrons move towards the dynode, where they hit it and produce a second electron, then they hit another diode, producing a second electron, and so on. The last end of the test dynode,

which captures electrons, is where the anode is located. When a photon collides with the photocathode in the tube, approximately one million second electrons are produced. The electric field used in a certain period is used to measure the current at the anode in photocells. The development of multi-channel solid-state detectors provides researchers with greater freedom to conduct research on a variety of topics. PMT detectors for analysis are reliable and durable. However, since each wavelength requires a different detector, they limit the number of points that can be calculated at once. Today's AES devices are equipped with state-of-the-art devices to help overcome this problem. Solid state detectors measure the spectrum of continuously emitted light. CID and CCD are two different types of solid state devices. These sensors have several rows of light-sensitive pixels. Both detectors generate and store electrical charges in response to electricity. The amount of charge created on the detector is inversely proportional to the intensity of electricity applied to the detector. The way the signal is read by the chip is very different between the two detectors. The charge coming out of the detector is collected by the charge amplifier in the CCD detector and the charge is measured. CID detectors, on the other hand, measure the value based on the voltage change caused by movement in the detector. The advantage of CID detectors is that they can detect signals with the best signal-to-noise ratio. CCDs are used in high-resolution and low-light applications and are capable of monitoring all wavelengths from 170 to 780 nm. CIDs use to monitor all the wavelengths from 165 to 800 nm.

- **Data Processing and Instrumentation Control:** The current detected at the anode of the photomultiplier tube is converted into a signal that can be sent to the computer and analyzed instantly. The spectrometer is controlled by a computer, and current generations of AES instruments still use computers to collect, process and display results. Different models have different computer control of these functions (Y. Anithakumari, 2021).

#### 4. Advantages of Atomic Emission Spectroscopy

- It is a sensitive method that can detect concentrations as low as 1 ppm.
- Studies require small samples.
- Working hours can be reduced if appropriate standards of comparison are available. 4. No need for sample planning.
- It is easy to observe the structure of solids and liquids (Y. Anithakumari, 2021).

#### 5. Disadvantages of Atomic Emission Spectroscopy

- Applies only to metals and metalloids. Non-ferrous metals cannot be detected.
- Measurement is very expensive.
- This is a destructive process that causes structural damage.
- It cannot be detected in concentrated solutions (Y. Anithakumari, 2021).

## 6. Applications

- Detection of agricultural products and foods can be done using the ICP-AES method.
- It can be used in earth sciences to examine rare earth elements found in rocks.
- Trace metals in metal alloys, steels, lubricants and gasoline can be detected using ICP-AES technology.
- In biology, the ICP-AES method can measure salt in milk, selenium in the liver, copper in tissue and lead in blood.
- Beer and wine will contain trace elements such as calcium (Ca), copper (Cu), iron (Fe), manganese (Mn), magnesium (Mg), phosphorus (P), potassium (K) and zinc (Zn). These metals can be detected using inductively coupled plasma atomic emission spectrometry.
- The concentration of Na<sup>+</sup> and K<sup>+</sup> ions in the human body is important for the completion of many metabolic processes. By diluting and absorbing the flame, the concentration of this drug in the serum sample can be calculated.
- The content of different metals and elements in soft drinks, fruit juices and alcohol can be calculated using flame photometry.
- Flame photometry can also be used to estimate the difference between metals and elements in soft drinks, juices and alcohol.
- Calcium and magnesium content in cement was measured by the AES method.
- Measure lead in gasoline using AES.
- AES is used to determine Ca, Mg, Na and K levels in blood and serum.
- According to WHO, AES is a reliable method for detecting toxic metals.
- AES can identify the metal content of soil.
- Contamination in petroleum products can be detected using AES (Y. Anithakumari, 2021).

## V. FLUORESCENCE SPECTROSCOPY

- 1. Introduction:** Fluorescence spectroscopy is a rapid and sensitive technique to determine the properties of the molecular environment and conditions in the sample. Fluorescence analysis outperforms other analytical methods due to its high sensitivity, specificity, ease of use, and low cost. It is a well-known and widely used method in biotechnology, forensic, environmental, business and medical applications. Both quantitative and qualitative analysis can benefit from the use of quality analysis tools (N. Kommu, 2014).
- 2. Principle:** The transition of electrons from the singlet ground state to the singlet excited state is caused by the absorption of ultraviolet or visible light. Because it is unstable, this state emits energy in the form of ultraviolet or visible light, which then returns to the singlet ground state. Fluorescence emission occurs when the fluorophore decays from the singlet electronic excited state to a sufficient vibrational level in the electronic ground state. The energy vibrational level patterns of the ground state and the excited electron are revealed in the fluorescence excitation and emission spectra, respectively (BK Sharma, 2011).

### 3. Instrumentation of spectrofluorometer (Figure 4)

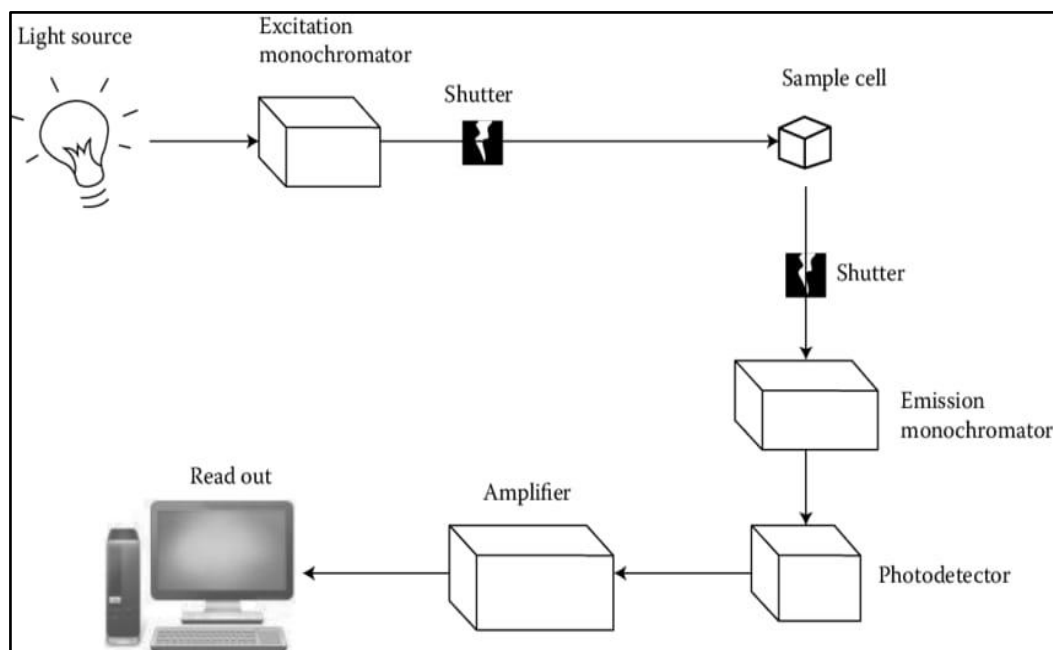

**Figure 4:** Instrumentation of Fluorescence Spectroscopy

- **Source of Light**
  - Mercury vapour lamp
  - Xenon arc lamp
  - Tungsten film
- **Filters**
  - Primary filters
  - Secondary filters
- **Monochromators**
  - Excitation monochromators
  - Emission monochromators
- **Sample Cells**
  - Detectors (BK Sharma, 2011)

### 4. Advantages

- It is one of the new technologies and its potential has not been used yet.
- Affects exposure. 1% is easily reached in fluorescence analysis.
- The method is very sensitive and specific as the wavelength of the excitation light and emission radiation can be selected (BK Sharma, 2011).

## 5. Disadvantages

- Careful buffering is required as the intensity of fluorescence can be highly correlated.
- Fluorescent molecules can be photochemically modified or destroyed by the UV light used for excitation.
- The presence of dissolved oxygen can cause strong photochemical degradation.
- Numbers of iodide and nitrogen oxides work well as extinguishing and degrading agents.
- Since this model has low accuracy for large volumes, it is not suitable for determining the basic properties of the model.
- The effectiveness of this technique is limited as not all elements and compounds show fluorescence (BK Sharma, 2011).

## 6. Application

- Determination of ruthenium
- Determination of boron in steel
- Determination of aluminium in the alloy
- Determination of chromium and manganese in steel
- Determination of uranium salt
- Rare earth terbium estimate
- Bismuth Estimate
- Determination of beryllium in silicate
- Prediction of 4 benzopyrenes
- Determination of Zinc
- Determination of Cadmium (BK Sharma, 2011).

## VI. IR SPECTROSCOPY

- 1. Introduction:** The study of the interaction of infrared radiation with information through absorption, emission, or reflection is called infrared spectroscopy (also known as infrared spectroscopy or vibrational spectroscopy). Use this technique to study and identify compounds or functional groups in solids, liquids, or gases. An infrared spectroscopy method or technique uses an instrument called an infrared spectrometer (or spectrophotometer) that produces infrared spectra. A plot of infrared light transmittance (or absorbance) versus frequency or wavelength on the horizontal axis can be used to describe the infrared spectrum. The reciprocal of the centimeter, sometimes called the wave number, is frequently used in infrared spectroscopy and has the symbol  $\text{cm}^{-1}$ . The symbol  $\mu$  stands for micron (formerly "micron") and is often used to represent the unit of infrared wavelengths. Micron and wave number are related to each other (C. Conti, 2008).
- 2. Principle:** The theory of infrared spectroscopy is based on the idea that molecules tend to absorb frequencies of light specific to their structure. The energy depends on the atomic size, the vibrational bonds involved, and the geometry of the molecule's surface. For

example, a molecule can absorb available energy in matter, causing it to spin faster or vibrate harder (C. Conti, 2008).

### 3. Instrumentation

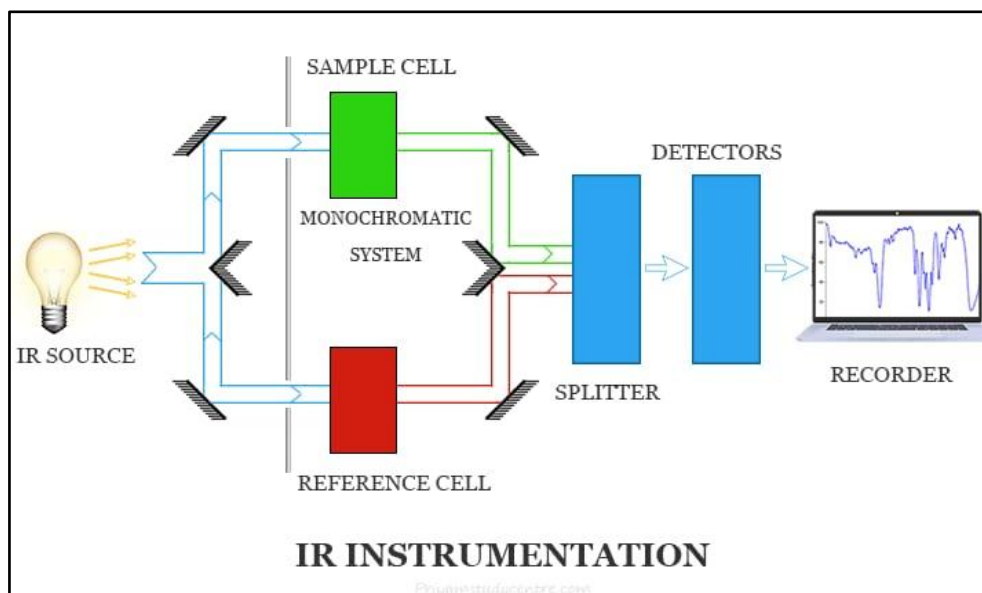

**Figure 5:** Instrumentation of Infrared Spectroscopy

Glass and quartz are optical materials with high absorption in the infrared region; therefore the equipment used to detect the infrared spectrum is different from the equipment used to detect the visible and ultraviolet regions. The principle of the infrared spectrometer is as follows.

- IR radiation sources
- Monochromators
- Sample cells and sampling of substances
- Detectors
- **Infrared Radiation Source:** Infrared instruments, like other types of absorption spectrometers, must be able to isolate narrow sources of radiation. Infrared radiation must be produced by an electrical source and:
  - It should be strong enough to detect
  - It should be stable
  - Extend to the desired wavelength

However, these only suck occasionally.

Various popular sources of infrared radiation are:

- Incandescent lamp

- Nernst Glower
- Earth source
- Mercury Arc
- **Monochromator:** An electronic device that emits radiation at different frequencies. It is important to select the desired frequency from the radiation source and reject radiation at other frequencies because the structure in the infrared spectrum absorbs only certain frequencies. This option is done using a monochromator with two elements:
  - Prism monochromator
  - Grating monochromator
- **Sample Cells and Material Sampling:** Since infrared spectroscopy is used to characterize solids, liquids, and gases, samples of all phases must be completed. But some models need to be made differently. However, the sample carrier must be transparent to infrared light. This is one of the different models at different levels.

A. Sampling of solids: Four methods are commonly used to prepare product samples. These are as follows:

  - Solid Run-in solution
  - Solid Films
  - Mull technique
  - Pressed Pellet Technique
  - Sampling of Liquids
  - Sampling of Gases
- **Detectors**
  - Bolometer
  - Thermocouple
  - Thermistors
  - Semiconductor Detectors
  - Pyroelectric Detector (C. Conti, 2008).

#### 4. Applications of Ir Spectroscopy

- Organic analysis. If two substances have the same infrared spectrum when compared, they must be the same substance.
- Design model. This method helps determine the structure of the unknown product.
- Check the purity of the mixture. While pure chemicals produce unique infrared spectra, impure compounds produce chaotic spectra containing many elusive bands. 4. The progress of the reaction can be monitored by observing the infrared spectrum.
- Distinguish between intramolecular hydrogen bonds and intramolecular hydrogen bonds. The easiest way to understand the type of hydrogen bonds found in organic

compounds is to examine them in dilute solutions using nonpolar solvents. (C. Conti, 2008).

## VII. NMR NUCLEAR MAGNETIC RESONANCE SPECTROSCOPY

- 1. Introduction:** One of the most important analytical techniques developed in recent years is nuclear magnetic resonance (NMR) spectroscopy. Many chemical and non-chemical substances, from single cells to organs and tissues, are examined with NMR. Many areas of this technology are currently under investigation and many NMR capabilities still need to be clarified and validated (J. Keeler, 2011).
- 2. Principle:** The principle of NMR is that various substances in the nucleus have unique magnetic fields that can be used to determine their structure and chemical composition. A simple NMR spectrometer uses a magnetic field and a special detector to measure changes. The charge nucleus migrates from low energy level (E1) to high energy level (E2) due to the force of the external magnetic field, the difference between E2 and E1 is represented by the symbol E, which depends on the energy of the force. . size of magnetic field and nuclear field current. When the frequency ( $\nu$ ) rhythm of electromagnetic radiation reaches the NMR signal, the nuclei move towards more energy (E1/E2) (J. Keeler, 2011).
- 3. Instrumentation (Figure 6)**

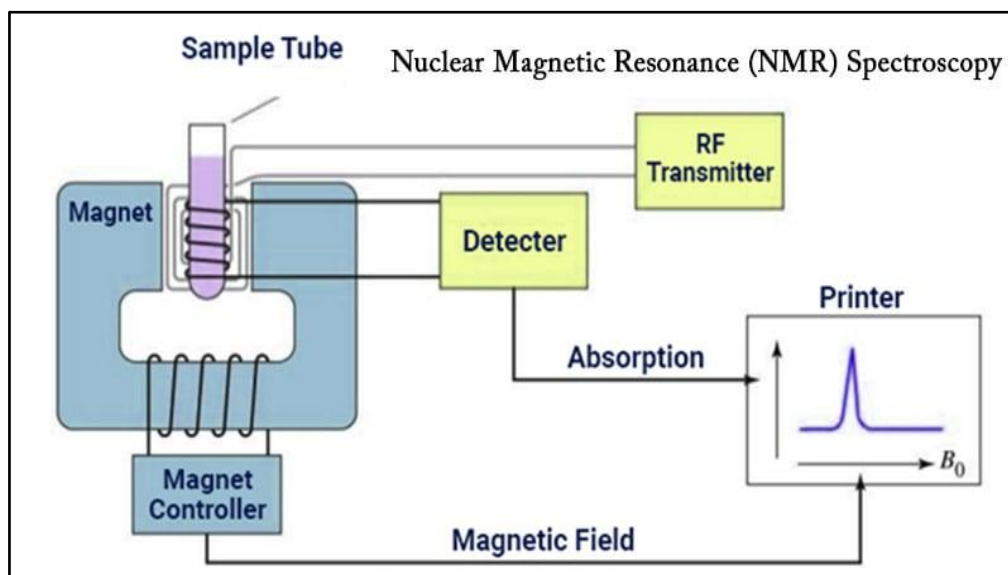

**Figure 6:** Instrumentation of Nuclear Magnetic Resonance Spectroscopy

NMR spectrophotometers are divided into two types according to what they measure.

- Single coil spectrometers: measure absorbance.
- Double coil spectrometer: measurement of resonance radiation.



The resolution of nuclear magnetic resonance spectrometer can be divided into low resolution and high resolution. The former can perform many analyzes of elements and is also known as a broad-line spectrometer.

The main points of NMR measurement are:

- **Sample Holder:** The length of the sample holder is 8.5 cm long and 0.3 mm in diameter. Since glass tubes are cheaper, they are often used as sample holders. The holding model has the basic features mentioned above.
  - It must be stable.
  - It must be possible.
  - It must be cheap.
  - It must be transparent to radio frequency radiation.
  - It should be an inert substance.
- **Sample Probe:** It records the sample tube in the magnetic field as it rotates around its own axis, which can produce fine lines and increase the resolution due to the decrease of magnetic field homogeneity. Depending on the device, the probe may be a single coil or a network of coils.
- **Permanent Magnet:** The most important feature of a permanent magnet or electromagnet is that it produces a magnetic field, that is, the strength and direction of the magnet should not changes from one place to another. Since the field strength is inversely proportional to the chemical change, it must be at least 20,000 guas.
- **Magnetic Coil:** It should be designed to produce NMR spectra. This can be done using a pair of Helmholtz coils placed on both side of the sample probe or a coil around a magnetic pole.

The following equation explains relationship between the resonance frequency of the atomic nucleus and the magnetic field (H<sub>0</sub>):

$$V = \text{constant} \times H_0$$

According to this equation, the relationship between frequency and magnetic field strength (H<sub>0</sub>) is as follows: direct. Make H<sub>0</sub> fixed, adjust the frequency first. If the radio frequency is fixed, the resonance frequency of the core should be changed by changing H<sub>0</sub>.

- **Sweep Generator:** If the frequency of precession is the same as the frequency of the electric current, the core will enter into resonance. Electronic scanning machine can be used to change the magnetic field, which is easier than changing the radio frequency.
- **RF Generator:** Radio Frequency transmitter is another name for RF generator. A radio frequency oscillator is used to generate radio frequency radiation to detect

sample molecules. As a result of the use of radio frequency, the nuclei switch from the ground state to the excited state. The resonance signal is generated by a coil around the sample.

- **RF Receiver:** Absorption and scattering are two processes that can occur when RF radiation passes through a magnetic structure. The resonance frequency can be determined by analyzing the absorption or dispersion.

The following technique is used to identify the resonance signal:

Use a radio frequency bridge in stepwise measurement. It causes the EMF output of the bridge to be seen as absorption and dissipation signals. Signals can be turned off mechanically.

Also known as the cross-coil or nuclear induction method, this method uses separate receiver coils using electromagnetic induction. In this case, the coils of the transmitter and receiver are placed perpendicular to the direction of the magnetic field and to each other.

- **Amplifier:** The RF receiver absorbs very weak signals. Therefore, data must be amplified before being sent to the data logger, which uses amplifiers to amplify the power.
- **Reading:** The NMR spectrum obtained from the device is recorded directly mechanically or electrically (G. Chatwal, 2022).

#### 4. Advantages

- It is the most effective method for analyzing the structure of nuclear structures.
- Easily prepare samples before testing.
- Both organic and inorganic compounds can be identified in various ways.
- Fingerprint techniques for chemical identification (G. Chatwal, 2022).

#### 5. Disadvantages

- Low sensitivity
- It is difficult to observe the desired spectrum when the spectra overlap.
- The molecular mass of the compounds cannot be determined.
- The price is too high.
- Size should be available for many models.
- It is most commonly used in liquid analysis (G. Chatwal, 2022).

#### 6. Applications

- **Diagnosis:** There are various protocols developed to determine the structures of the unknown substances from its NMR spectrum.

Here are some examples:

The total number of protons in the unknown must equal the total number of original NMR signals.

Chemical shift indicates the type of hydrogen atoms present.

For example: methylene, methyl, ether, etc.

Spin-spin splitting or multiplicity indicates the fundamental group configuration in a molecule.

The number of atoms in each group of the hydrogen nucleus can be calculated from the peak area.

- **Quantitative Analysis**

- **Determination of Composition or Percentage Purity:** This method is utilized for calculating the percentage purity of the active pharmaceutical ingredient. NMR spectra are reported for these samples and the compounds used in the samples. By comparing the peak areas of the sample, the purity percentage of the product will be calculated from this spectrum.
- **Chain Length of the Surfactant:** The chain length of the surfactant can be easily determined by looking at the NMR spectrum. If we look at the spectrum of the chemical above, we can see that it has four peaks, which means it has four types of hydrogen. From this we can determine the chain length of the surfactant.
- **Hydrogen Analysis:** Using the spectrum of the material, we can quickly determine the presence of hydrogen in the material.
- **Humidity Analysis:** The molecular formula of water has two hydrogen atoms and one oxygen atom. Hydrogen is unprotected due to bonding between less electronegative atoms. The absorption peak is shifted below the field to accommodate deshielding.
- **Hydrogen Bonds:** The difference between intramolecular and intermolecular hydrogen bonds (such as chelation) can be easily distinguished using NMR. The hydrogen atom is deprotected and moves downward because the hydrogen bond has to transfer the electron cloud from the hydrogen atom to nearby electronegative atoms such as F, N, and O.

- **Determination of Keto-Enol Tautomerism**

Example: Acetylacetone

The keto-enol form of any compound can be determined by NMR spectroscopy based on the number of peaks. 4. Study of isotopes other than protons: Nuclear magnetic resonance spectroscopy can be used to study nuclei that have magnetic moments in addition to protons. For example: fluorine and phosphorus. The  $^{31}\text{P}$  bearing rotation number  $1/2$  shows a sharp nuclear magnetic resonance peak with a resonance frequency of 24.3 MHz at 1400 Gauss.

- **Clinical Applications:** There are two ways NMR is used in medicine for diagnostic purposes in humans:
  - It is used to detect abnormalities in urinary metabolism such as phenylketonuria and maple urine syndrome.

- Magnetic resonance imaging (MRI) is an important diagnostic tool used to check the functions and structures of the human body and it is very safe to perform (G. Chatwal, 2022).

## VIII. MASS SPECTROSCOPY

- 1. Introduction:** Mass spectrometry is an analytical method that helps scientists study protein-protein interactions by identifying biomolecules or proteins found in biological samples. The molecular weight of the product is measured by weighing. Only picomolar doses are required. Excellent precision and sensitivity for small organic molecules with standard error of 5 ppm. Can identify post-transcriptional modifications and amino acid changes in biological systems. The process occurs when molecules and electrons collide with light rays. Molecules are ionized and broken into many pieces. Each ion type has a unique mass-to-charge ratio. Its value is the  $m/e$  ratio. The  $m/e$  ratio expresses the molecular weight of the ion (P. Dharmadhikari, 2022).
- 2. Principle:** Matter or molecules are divided into electrons depending on their mass-to-charge ratio; these are then accelerated, deflected and finally focused on the device. Ion separation is based on mass-to-charge ( $m/z$ ) ratio, ion bias is based on charge, mass, and velocity, and detection is proportional to ion abundance (P. Dharmadhikari, 2022).
- 3. Instrumentation (Figure 7)**

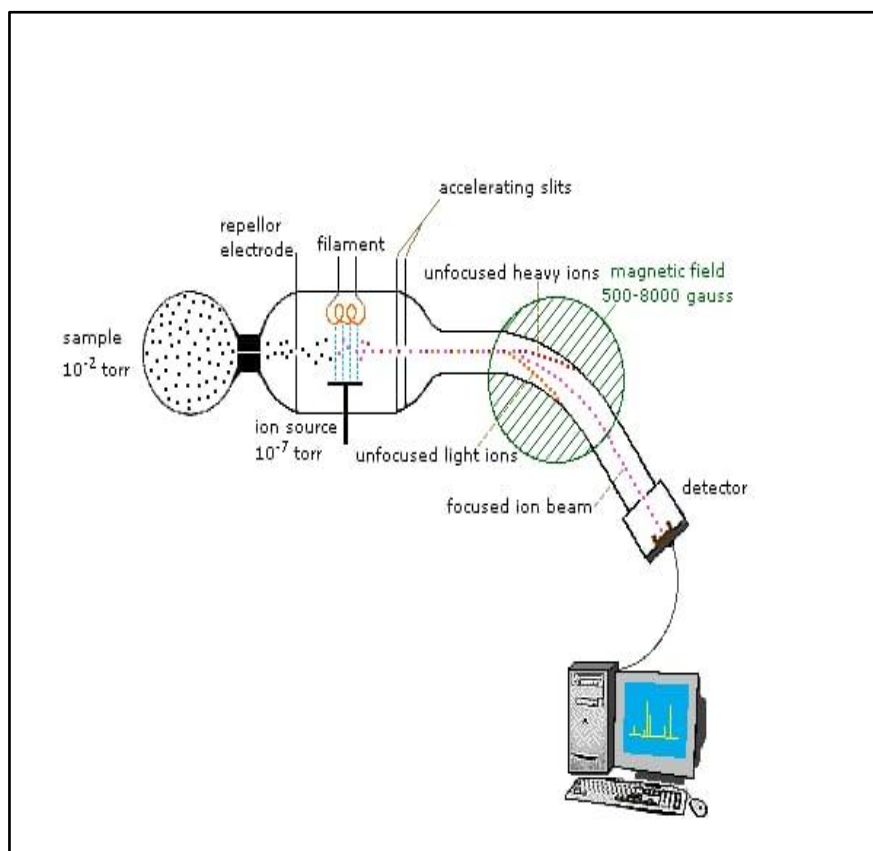

**Figure 7:** Instrumentation of Mass Spectrometry

- **Intel System / Sample Preparation:** Sample vapour must be present in the mass spectrometer so that the sample can enter the ionization chamber. There is also a heating inlet for gaseous sample exchange. Subsamples can be heated in a beaker before being placed in the ionization chamber. It is important to remember that no structure is thermally stable in this case. Non-volatile materials and liquids will evaporate instantly in the ionization chamber. Only a small fraction passes through the ionization chamber, where only about 0.1% is ionized.
- **Ion Source:** The sample enters the ionization chamber through the inlet system. The sample molecules are exposed to radiation, causing the molecules to ionize.  
Ion sources:
  - Knudsen cell
  - Surface ionization
  - Spark source ionization
  - Chemical ionization
- **Magnetic Field:** Particles in the electric field are accelerated towards the magnetic field. They must follow the curve due to the strength of the magnetic field.
- **Analyzer**
  - Separates ions according to their size.
  - It must have an ion conduction heart.
  - Requires high resolution.
- **Detector**
  - The relative number of ion fragments for each group is determined by the ion addition mechanism.
  - Mass spectrometers can use different types of detectors. In most experiments, electron multipliers act as detectors.
  - Photographs coated with silver bromide emulsions sensitive to high-energy ions are another type of capture.
  - Photographic images provide higher resolution than electronic devices (P. Dharmadhikari, 2022).

#### 4. Advantages

- High sensitivity - ability to detect very small quantities)
- High selectivity - Ability to distinguish molecules in a mixture High temporal resolution
- Low price
- Small example
- Fast
- Different isotopes
- The combination can be combined with GC and LC, or proteins or peptides etc. Can be mixed for. (P. Dharmadhikari, 2022).

## 5. Disadvantages

- Do not give information directly (although we can determine this)
- Pure compound is needed.
- Problems arise with non-converting drugs (P. Dharmadhikari, 2022).

## 6. Applications

- The molecular weight, molecular formula, and fragmentation pattern in the mass spectrum of the pure substance help identify the substance. One of the best ways to determine the molecular weight of a substance is by mass spectrometry. The size of the molecule can be determined by the size of the peak of the highest m/e in the mass spectrum of an object bombarded by moving electrons. This will help determine the molecular weight. Similarly, the molecular formula of a place can be found.
- The formation of polymers, natural compounds and pure isotopes can be analyzed using mass spectrometry.
- Because the stable ions consisting of cis and trans ions can be very different, mass spectrometry can be used to distinguish cis and trans isomers.
- Mass spectrometry also helps in studying free radicals, determining bond strength, measuring sublimation temperature, and other tasks.
- Hydrocarbons, petroleum products, lubricants, etc. Similar chemicals such as can be effectively detected using spectrometry.
- Mass spectrometry can be used for the analysis of elements, minerals and superconductors in alloys in inorganic trace analysis (A. V. Kasture, 2008).

## REFERENCES

- [1] Arthus , Vogel, Text book of quantitative analysis ,page no;855.
- [2] B. K. Sharma; A text book of instrumental methods of chemical analysis; Page.No:619 - 736.
- [3] BK Sharma, Instrumental methods of chemical analysis, Molecular fluorescence spectroscopy [2011] page no: S537-S568.
- [4] C. Conti, P. Ferraris, E. Giorgini, C. Rubini, S. Sabbatini, G. Tosi, J. Anastassopoulou, P. Arapantoni, E. Boukaki, S FT-IR, T. Theophanides, C. Valavanis, FT-IR Microimaging Spectroscopy: Discrimination between healthy and neoplastic human colon tissues , J. Mol Struc, 2008; 881: 46-51.
- [5] Diletta Amia, Tui Nerib, Antonino Natalelloa, Paolo Mereghettic, Silvia Maria Dogliaa, Mario Zanonib, Maurizio Zuccottid, Silvia Garagnab, and Carlo Alberto Redib. —Embryonic Stem Cell Differentiation Studied by FT-IR Spectroscopy| Biochimica et Biophysica Acta, 2008; 1783: 98-106.
- [6] Douglas A Skoog, Donald M west, F James holler, Stanley R crouch, Molecular fluorescence spectroscopy ,Text book of Fundamentals of analytical chemistry ,edition:8, page no:826-838 .
- [7] Dr. A. V. Kasture, Dr. K. R. Mahadik, Dr. S. G. Wadodkar, Dr. H. N. More; Pharmaceutical Analysis; volume-II; page. No: 222 – 233.
- [8] Dr. A. V. Kasture, Dr. K. R. Mahadik, Dr. S. G. Wadodkar, Dr. H. N. More; Pharmaceutical Analysis; volume-II; page. No: 249.
- [9] Dr.S. Ravishankar, Text book of pharmaceutical analysis: Flurimetry, edition 4, page no:3-18.
- [10] G Verma, DR. M Mishra, “Development and Optimization of UV VIS Spectroscopy-A Review”, World Journal of Pharmaceutical Research, 2018,7(11),1170-1180.
- [11] G. Vergoten and T. Theophanides, Biomolecular Structure and Dynamics: Recent experimental and Theoretical Advances, NATO Advanced Study Institute, Kluwer Academic Publishers, The Netherlands, 1997; 327.
- [12] Ganesh S, et al. “A Review on Advances in UV Spectroscopy”, Research J. Science and Tech. 2020,12(1),47-51

SPECTROSCOPIC TECHNIQUES FOR IDENTIFICATION OF  
DRUGS IN DIFFERENT PHARMACEUTICAL PREPARATIONS

- [13] Gurdeep R. Chatwal, Anand Sharma Instrumental method of Analysis 5<sup>th</sup> edition, Himalaya publishing house PVT.LTD, 2002 pp 2.566-2.587.
- [14] Gurdeep R. Chatwal, Sham K. Anand; A text book of instrumental methods of chemical analysis; Page. No: 2.185-2.220.
- [15] [https://chem.libretexts.org/Bookshelves/Analytical\\_Chemistry/Analytical\\_Chemistry\\_2.1\\_\(Harvey\)/10%3A\\_A\\_Spectroscopic\\_Methods/10.07%3A\\_Atomic\\_Emission\\_Spectroscopy](https://chem.libretexts.org/Bookshelves/Analytical_Chemistry/Analytical_Chemistry_2.1_(Harvey)/10%3A_A_Spectroscopic_Methods/10.07%3A_Atomic_Emission_Spectroscopy).
- [16] <https://www.chemistrylearner.com/atomic-emission-spectroscopy.html>. Dodrecht, 1984. Publishing Co. Dodrecht, 1989; 415.States of America. McGraw Hill, 1999. Study Institute, D. Reidel Publishing Co. Dodrecht, 1984, 646.
- [17] J L Aldabib, M F Edbeib, “The Effects of Concentration based on the absorbance form the Ultraviolet Visible Spectroscopy”, International Journal of Science Letters, 2020, 2(1): 1-11.
- [18] John A. Dean. —Lange’s Handbook of Chemistry| Section 7.5. Fifteenth Edition. United
- [19] Keeler J. Chichester: John Wiley & Sons; 2011. Understanding NMR Spectroscopy.
- [20] Kommu Naresh, Applications of Fluorescence spectroscopy, Journal of Chemical and Pharmaceutical sciences, [2014], page no: 18-21.
- [21] M. Patil, “Advantages and Disadvantages of UV Visible Spectroscopy”, NOV 2018, <https://chrominfo.blogspot.com/2018/11/advantages-and-disadvantages-of-uv.html?m=1>.
- [22] M. Petra, J. Anastassopoulou, T. Theologis & T. Theophanides, Synchrotron micro-FTIR spectroscopic evaluation of normal paediatric human bone, J. Mol Structure, 2005; 78: 101.
- [23] Melissa A. Page and W. Tandy Grubbs, J. Educ, 1999; 76(5): 666.
- [24] Modern Spectroscopy, 2nd Edition, J.Michael Hollas, ISBN: 471-93076-8.
- [25] P. Kolovou and J. Anastassopoulou, —Synchrotron FT-IR spectroscopy of human bones. The effect of aging|. Brilliant Light in Life and Material Sciences, Eds. V. Tsakanov and H. Wiedemann, Springer, 2007; 267-272.
- [26] Paudel S, Kumar S, Mallik A. Atomic Absorption Spectroscopy: A Short Review. EPRA Int. J. Res. Dev.(IJRD). 2021;6:322-7.
- [27] Petru Pascuta, Lidia Pop, Simona Rada, Maria Bosca, and Eugen Culea. —The Local Structure of Bismuth Borate Glasses Doped with Europium Ions Evidenced by FT-IR Spectroscopy| Journal of Materials Science: Materials in Electronics, 2008; 19: 424-428.
- [28] Pooja A.Dharmadhikari, Prof. Santosh Waghmare, Dr.H.V.Kamble, Review Article on: Mass Spectrometry, International Journal of Pharmaceutical Research and Applications, Volume 7, Issue 3 May-June 2022, pp: 410-416.
- [29] Schuster, K.C., Mertens, F., Gapes, J.R., —FT-IR spectroscopy applied to bacterial cells as a novel method for monitoring complex biotechnological processes|, Vibrational Spectroscopy, 1999; 19: 467-477.
- [30] T. Theophanides Fourier Transform Infrared Spectroscopy, D. Reidel Publishing Co.
- [31] T. Theophanides, C. Sandorfy) Spectroscopy of Biological Molecules, NATO Advanced
- [32] T. Theophanides, Infrared and Raman Spectra of Biological Molecules, NATO Advanced Study Institute, D. Reidel Publishing Co. Dodrecht, 1978; 372.
- [33] T. Theophanides, Inorganic Bioactivators, NATO Advanced Study Institute, D. Reidel
- [34] T. Theophanides, J. Anastassopoulou and N. Fotopoulos, Fifth International Conference on the Spectroscopy of Biological Molecules, Kluwer Academic Publishers, Dodrecht, 1991; 409.
- [35] U. Holzgrabe, I. Wawer, B. Diehl; A text book of NMR spectroscopy in Pharmaceutical analysis; Page. No: 277-279.
- [36] Wikipedia, the free encyclopedia. Infrared spectroscopy <http://en.wikipedia.org>, July 28, 2007. Mount Holyoke College, South Hadley, Massachusetts. Forensic applications of IR <http://www.mtholyoke.edu> July 28, 2007.
- [37] Willard, Merritt Dean; selte; Instrumental method of analysis; 6th edition; Page. No: 422 – 454.
- [38] Y. Anithakumari, Dr. M Sathishkumar, REVIEW ON ATOMIC EMISSION SPECTROSCOPY, Vol. 6 Issue. 10 (October-2021) EPRA International Journal of Research & Development (IJRD). <https://doi.org/10.36713/epra2016>.