

APPLICATIONS OF HYPHENATED TECHNIQUES IN PHARMACEUTICAL SCIENCES

Abstract

The hyphenation term was introduced by Thomas Hirschfield in 1980. Hyphenated techniques are exponentially to deal with various complicated challenges faced by analyst in analytical chemistry. It is the fusion of chromatographic methods and spectrometric or spectroscopic methods. Chromatographic methods are separation methods which separate component in the complex mixture like gas chromatography (GC), liquid chromatography (LC), high-performance liquid chromatography (HPLC) and capillary electrophoresis (CE). Spectroscopy use to elucidate the structure, molecular mass of compounds like UV, IR, Mass, Raman, Fluorescence spectroscopy. The remarkable improvements in hyphenated analytical methods over the last two decades have significantly broadened their applications in the analysis of biomaterials, especially natural products. Nowadays, various types of hyphenated techniques incorporating different types of interfaces are available commercially to show better analysis of the samples is components specificity, accuracy, precision. In this chapter, we have emphasized on most common types of double and triple hyphenated techniques like GC-MS, LC-MS, LC-FTIR, LC-NMR, LC-NMR-MS, etc and their applications in the field of pharmaceutical sciences.

Keywords: Hyphenated Technique; GC-MS; LC-MS; LC-FTIR; LC-NMR.

Authors

Lata Potey

Shree Sainath College of Pharmacy
Dawalameti, Nagpur, Maharashtra, India.

Ashwini Armarkar

Shree Sainath College of Pharmacy
Dawalameti, Nagpur, Maharashtra, India.

Shilpa Chapekar

Shree Sainath College of Pharmacy
Dawalameti, Nagpur, Maharashtra, India.

Yogini Shete

Shree Sainath College of Pharmacy
Dawalameti, Nagpur, Maharashtra, India.

Pooja Birade

Shree Sainath College of Pharmacy
Dawalameti, Nagpur, Maharashtra, India.

Suchita Waghmare

Department of Pharmaceutical Sciences
Nagpur, Maharashtra, India.
latapotey@rediffmail.com

I. INTRODUCTION

A hyphenated technique is a combination (or) coupling of two different analytical techniques with the help of proper interface. Mainly chromatographic techniques are combined with spectroscopic techniques. [1] In the chromatography, the pure or nearly pure fractions of chemical components in a mixture were separated and spectroscopy produces selective information for identification using standards or library spectra. “The coupling of the separation technique and an on-line spectroscopic detection technology will lead to a hyphenated technique. [2] A Hyphenated technique is combination (or) coupling of two different analytical techniques with the help of proper interface. [3] The term hyphenated techniques range from the combination of separation- separation, separation-identification& identification- identification techniques. [4] The term “hyphenation” was first adapted by Hirsch Feld in 1980 to describe a possible combination of two or more instrumental analytical methods in a single run (Hirschfeld, 1980). The aim of the coupling is to obtain an information rich detection for both identification and quantification compared to that with a single analytical technique. [5] See table 1 for the classified hyphenated techniques.

Table 1: Various Types of Hyphenated Techniques

Sr. no	Separation Technique	Hyphenated Mode
1.	Liquid Chromatography	a) Liquid Chromatography-Fourier Transform Infrared Spectrometry (LC-FTIR)
		b) Liquid Chromatography-Mass Spectrometry (LC/MS)
		c) Liquid Chromatography-Nuclear Magnetic Resonance Spectroscopy (LC/NMR)
2.	Thin layer Chromatography	a) Thin layer Chromatography-Mass spectrometry (TLC/MS)
		b) Thin layer Chromatography-Surface enhanced Raman Spectroscopy (TLC-SERS)
3.	Gas Chromatography	a) Gas Chromatography- Mass Spectrometry (GC/MS)
		b) Gas Chromatography- FTIR-MS (GC-FTIR-MS)
		c) Gas Chromatography- Fourier Transform Infrared Spectrometry (GC-FTIR)
		d) Gas Chromatography-Inductively coupled Plasma Mass Spectrometry (GC-ICPMS)
4.	Capillary Electrophoresis	a) Capillary Electrophoresis-Nuclear Magnetic Resonance Spectrometry (CE/NMR)
		b) Capillary Electrophoresis- Surface enhanced Raman Spectrometry (CE-SERS)
		c) Capillary Electrophoresis- Mass Spectrometry (CE/MS)
5.	Supercritical fluid chromatography extraction (SFC/SFE)	a) Supercritical fluid chromatography extraction -Fourier Transform Infrared (SFC-FTIR)
		b) Supercritical fluid chromatography extraction - Capillary Gas Chromatography Mass Spectrometry (SFE-CGC-MS)

II. TYPES OF HYPHENATED TECHNIQUE

1. Double Hyphenated Techniques: The hyphenated techniques with the combination of two analytical techniques at a particular interface are called as double hyphenated techniques.

- **GC-MS:** This technique is developed by the coupling of gas chromatography and mass spectrometry. Most popular method applied for the research and development purpose in the field of analysis. [6] It is used in the detection of drug sample, fire examination, explosive exploration, environmental research, food examination, flavor analysis, unknown sample testing, additionally it can be used in trace element detection, it allows analysis and detection even of tiny amounts of a substance. [7, 8,] This technique is used to analyze volatile, small compounds which can be stable at high temperature, compound with polar substituent's like OH group want to be easily derivatized for analysis by this technique. [9] The most common method of derivatization is to convert analyte with polar group to their trimethylsilyl derivatives. In the actual procedure is a injection of sample in injection port of GC device, vaporization, vaporized, separation in the GC column, analysis by the detector of Mass spectrometry and recording by a recorder.[10]The spectra which is obtained by this hyphenated technique offer more structural information based on the interpretation of fragmentations. The fragment ions with different relative abundances can be compared with library spectra.[11]

The most common type of detector used in this GCMS technique is the quadrupole mass spectrometer, also called as 'Mass Selective Detector' referred by the Hewlett-Packard. Another common detector in MS is the ion trap mass spectrometer. Additionally one may find a magnetic sector mass spectrometer, however these particular instruments are expensive and bulky and not typically found in high-throughput service laboratories. Other detectors may be encountered such as time of flight (TOF), tandem quadrupoles (MS-MS) or in the case of an ion trap MS^n where n indicates the number mass spectrometry stages.[12] (The flow diagram of GCMS has been shown in figure 1)

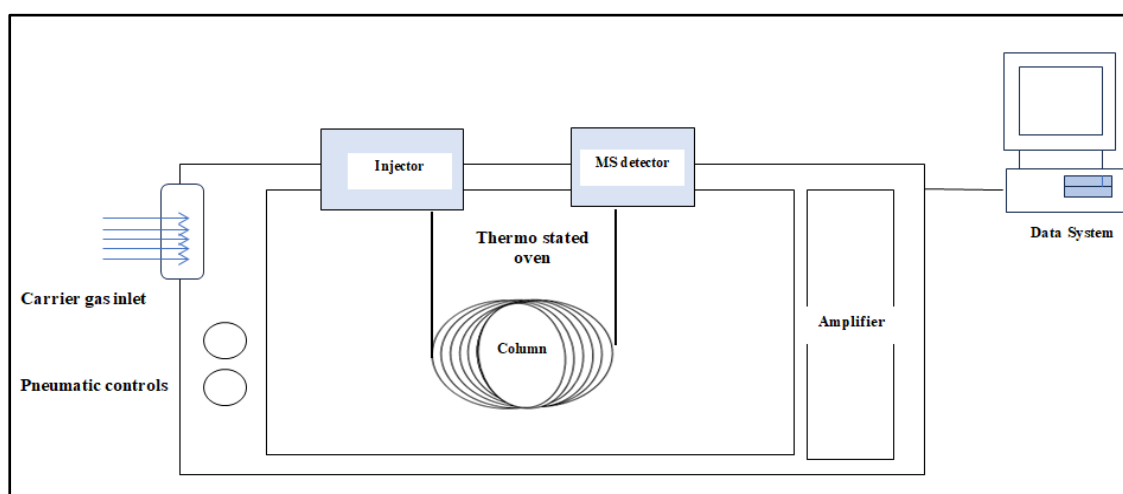

Figure 1: Schematic Diagram of GC-MS.

- **LC-MS:** This hyphenated technique is the fusion of liquid chromatography (LC) with mass spectrometry (MS) used to examine inorganic, organic, biochemical and natural compounds. [13] In addition to pharmaceutical field, it is found useful in food processing, agriculture, cosmetic, and biotechnology. [14] It begins to be used in clinical applications also. This system is consists of an interface which can transfer the compound separated from LC column into MS ion source. [15]The LC-MS interface is a mechanically simple component which helps in preserving the chemical identity of the product separated by LC by removing maximum solvent used in chromatography while transferring analyte. As per the requirement, the interface should not interfere with the ionizing efficiency and vacuum conditions of the MS system. [16]

Most recently used LC-MS interfaces are found to be based on strategies of atmospheric pressure ionization (API) such as atmospheric pressure chemical ionization (APCI), electron ionization (ESI), atmospheric pressure photoionization (APPI). [17]These are newer MS ion sources that facilitate the transition from a high pressure environment (HPLC) to high vacuum conditions needed at the MS analyzer. Although these interfaces are described individually, they can also be commercially available as dual ESI/APCI, ESI/APPI, or APCI/APPI ion sources Various deposition and drying techniques were used in the past (e.g., moving belts) but the most common of these was the off-line MALDI deposition. A new approach still under development called direct-EI LC-MS interface, couples a nano HPLC system and electron ionization equipped mass spectrometer. [18] (The flow diagram of LCMS has been shown in figure 2)

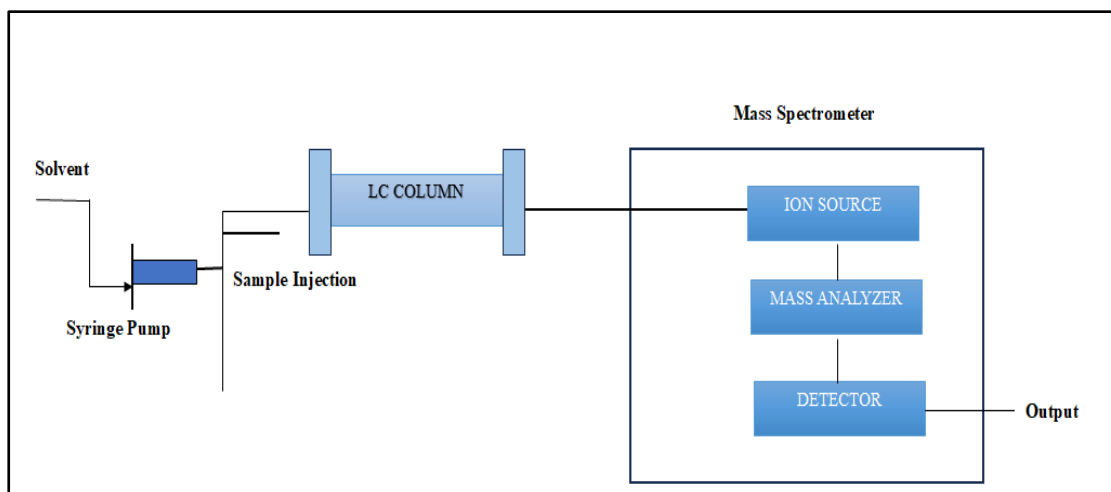

Figure 2: Schematic Diagram of LC-MS.

- **LC-IR:** It is an analytical technique which is a combination of liquid chromatography (LR) and infrared spectroscopy (IR) which permit easy in sample detection and identification. [19] LC is a separation method and IR spectroscopy is helpful to characterize the compound by the presence of functional group in the structure, also detect the structural isomers. This technique (LC-MS) was developed on the basis of two approaches. The first approach is a very simple that consists of flow cell through which effluents are passes from LC column to IR detector to give the IR spectra.[20]

There are so many advantages of this approach like simple operation, low maintenance, real time detection. Another approach is an elimination of LC solvent before to IR detection. In this approach an interface is used to evaporate the eluent and deposit the separated compounds onto a substrate suitable for IR detection. [21] The primary advantages of solvent-elimination LC/IR are the possibility to obtain full spectra of the analytes and the considerably enhanced sensitivity when compared to flow-cell detection. Unfortunately, common LC solvents, and particularly aqueous eluent, are not easily removed and therefore the evaporation interfaces are often rather complex. Literature have shown that many analyst only prefer to use electrospray interface for this coupling technique which is flexible interface used for the analysis of both micro molecules and macromolecules, cationic and anionics and for the thermally labile compounds. There are other interfaces also like atmospheric pressure chemical ionization (APCI), and atmospheric pressure photoionization (APPI). [22] LC/IR is more and more being recognized as a feasible and rewarding technique. With the capability to separate complex mixtures and characterize different molecules, LC-IR has a number of potential applications. One such use is in environmental analyses, where trace amounts of pollutants need to be detected and analyzed. LC-IR has been used to identify trace amounts of herbicides in water samples, with solvent elimination applied to enhance sensitivity. [23] Another use is for the characterization of bacteria, which extends to medical, food, agricultural and even military applications. Using LC's separation capability alongside the conventional method of FT-IR, researchers obtained clean spectra of cellular components. That enables a better understanding of the compositional makeup of various bacteria. [24]

- **LC-NMR:** This hyphenated technique is a combination of liquid chromatography (LC) and nuclear magnetic resonance spectroscopy (NMR) which involve separation followed by sample detection by NMR spectroscopy. LC-NMR is an influential analytical technique helpful to resolve complex mixture. [25] It has wide range of applications. As a microanalytical method, HPLC-NMR allows the detection of various groups of natural compounds and other biomolecules in the nanogram or even picogram range and, therefore, can contribute to the solution of problems of biochemical, physiological and chemo ecological research.[26]It is a valuable tool for natural product analysis. In general, the online technique is used to provide a rapid overview of the major components occurring in plants and other sources of natural products. The more sensitive stopped-flow method allows the detection and structure assignment of even minor components and enables the use of various homo- and heteronuclear correlation NMR experiments.[27] However, unambiguous structure assignment of novel compounds of unexpected structural types requires information from other analytical methods, especially MS. Complete structure elucidation, together with stereochemical information, by multiple online combinations including NMR is possible but currently is rather the exception.[28] Rapid development in analytical chemistry is expected to overcome present limitations of HPLC-NMR.LC-NMR is also combined with other techniques such as two-dimensional NMR measurements (LC-2D NMR), mass spectroscopy or MS (LC-NMR/MS) and solid phase extraction or SPE (LC-SPE-NMR) to give rise to a whole new range of separation and characterization applications that have a high sensitivity. [29](The flow diagram of LCMS has been shown in figure 3)

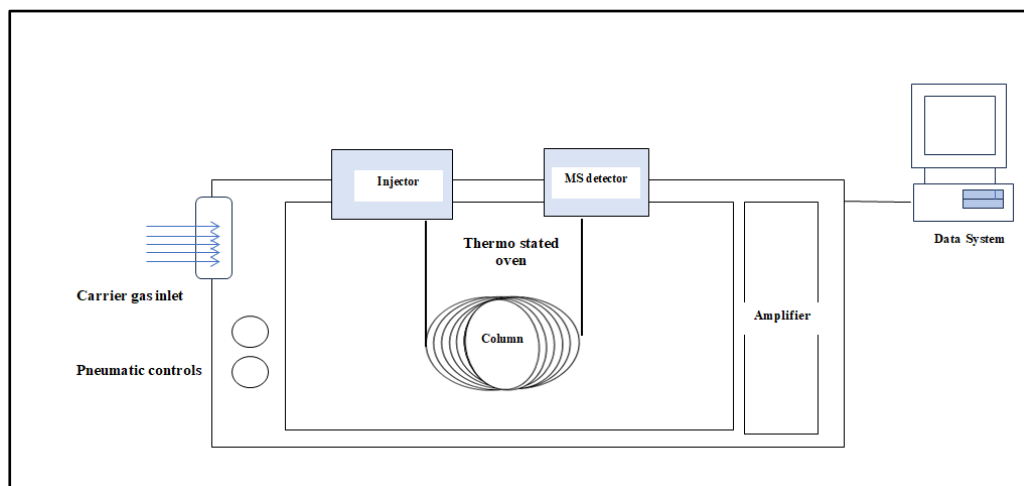

Figure 3: Schematic Diagram of LC-NMR

2. Triple Hyphenated Techniques: The hyphenated techniques with a combination of three different analytical techniques at particular interfaces are called as triple hyphenated techniques.

- LC-NMR-MS:** This technique combines three analytical techniques to give hybrid platforms combining LC with NMR and MS enables a faster and more accurate characterization of unknown compounds in complex clinical and pharmaceutical samples, and even natural product extracts. [30] Hence the complementary information generated by the two detectors can be used for unequivocal structure elucidation of expected analytes without prior component isolation. Accordingly, one finds applications of LC-NMR-MS in identification/characterization of degradation products, impurities, metabolites, natural products, etc. Pure components from the complex mixture of natural product extracts and in vivo matrices containing metabolites, which are difficult to be enriched and prepared synthetically, have been more frequently analyzed by LC-NMR-MS systems.[31] LC-NMR-MS is very useful in the identification of metabolites having ambiguous structures, for example, when the position of hydroxylation could not be fixed because of availability of multiple sites. This combination provides mass and NMR information in a single run without any isolation and enrichment. There are number of reports in the literature where LC-NMR-MS has been used for the identification of metabolites. Most of the studies have involved metabolite identification in urine and other biofluids. [32]
- LC-API-MS:** This technique has been produced by the combination of high performance liquid chromatography (HPLC), atmospheric pressure ionization (API), and Mass Spectrometry. It is developed for determination and characterization of component in complex biological mixtures. [33] Direct identification of a large number of proteins can be done by LC-API-MS in the biological assay. It is also used in analysis of protein in urine and blood plasma. Such applications require efforts by analyst while preparation of samples. Common methods for the sample preparation in various biological assays are liquid-liquid extraction (LLE), size exclusion chromatography (SEC), hydrophilic and hydrophobic solid phase extraction (SPE), affinity chromatography (AC), isoelectric focusing chromatography (IFC). [34]

The samples were separated using the liquid chromatography HPLC 1100 micro series (Agilent, Waldbronn, Germany) and analyzed using an electrospray-coupled Q-ToF mass spectrometer (Ultima, Waters-Micromass, Manchester, UK). The HPLC system was controlled by ChemStation software (Rev. B01.01, Agilent, Waldbronn, Germany) and the mass spectrometer by MassLynx 4.0 software (Waters-Micromass, Manchester, UK). The data analysis was also performed by the MassLynx 4.0 software. [35]

- **LC-ESI-MS:** LC-ESI-MS is a hyphenated mass spectrometry technique. This method combines the resolution of high-performance liquid chromatography (HPLC) separation with the high mass accuracy of the mass spectrometer. It is powerful technique used for the analysis of complex oligonucleotides mixture very efficiently and readily. [32]The instrumentation part of LC-ESI-MS/MS system consisted of an Agilent 1200 HPLC System (Santa Clara, CA, USA) and a Thermo Finnigan TSQ triple-quadrupole mass spectrometer (San Jose, CA, USA) equipped with an electrospray ionization (ESI) interface. Chromatographic separation carried out through a Venusil HILIC column (150 mm × 4.6 mm, 5 μm; Agela, USA) and an isocratic elution with the mobile phase of acetonitrile/water/formic acid (75:25:0.1, v/v/v). [36]

III. APPLICATIONS OF HYPHENATED TECHNIQUES

1. **Natural Product Analysis:** Hyphenated Technique used for the quick structural analysis of natural compounds in crude plant extracts and their dereplication. There are various online identification strategies that can be combined with hyphenated procedures. Online chemical analysis of *Erythrinavogelii* (Leguminosae) elements and online assessment of their antifungal potential study of unstable natural compounds using stop-flow and on-flow techniques LC-NMR along with being a useful technique for reproducing natural compounds in crude plant extracts, LC-NMR can also be used in conjunction with conventional in-mixture NMR investigations to analyze the structural composition of labile products in simple fractions. Study of the antioxidant compounds from *Eriophorumscheuchzeri* (Cyperaceae) by a combination of on-flow LC-NMR and online bioassay and complementary at-line CAP-NMR measurements as stated before, on-flow LC-NMR did not always provide sufficient information for the de novo structure determination of natural products and, thus, at-line spectra can be recorded with more sensitive probes such as CAP-LC-NMR. This aspect is illustrated here by the investigation of the antioxidant compounds of the swiss alpine plant *CyperaceaeEriophorumscheuchzeri*. [37, 38]
2. **Structural Elucidation of Impurities:** Structures based on MS Fragmentation in most cases, pseudomolecular ions are produced using atmospheric pressure ionization procedures, but only fragments can reveal information about the structure of the underlying substance. As a result, fragments must be formed in a subsequent phase. Depending on the instrument being utilized, this process is referred to as MS/MS or MS. In the first step of MS/MS, the pseudomolecular ion is chosen and separated. The ion is then given energy by, for instance, being injected into a collision cell that contains an inert gas at a slightly higher pressure. Through several collisions, the ion is energized and

fragmented into smaller pieces. These daughter ions are discovered in the final phase. [39]

- 3. Chiral Amino Acid Analysis with MS Detection:** After the peptide has been hydrolyzed, a chiral amino acid study is often conducted to characterize diastereomeric peptides. The analysis can be carried out by converting the respective amino acid enantiomers into diastereomers that can be separated using reversed phase chromatography after derivatization of the amino acids using Marfey's reagent (Bruckner and Keller-Hoehl, 1990). It would be necessary to have access to reference materials in order to identify the corresponding pairs of diastereomers. Additionally, optimizing the separation may be quite difficult, particularly with a higher number of amino acids. [40]
- 4. In Food Analysis:** The analysis of food samples is done for a variety of reasons. Scientists work in all key areas of the food industry, analyzing food and food components. As a result, this network consists of food producers, suppliers of food ingredients, as well as governmental, academic, and service laboratories. To ensure food safety comes first. For instance, if a food contains harmful substances like pesticides, herbicides, or poisonous metals, harmful bacteria or other microbes like salmonella, or offensive materials like glass, wool, or insects, it may be deemed unhealthy. [41]

Despite playing a significant role in food analysis, MS cannot be used as a stand-alone approach due to the complexity of food matrices. Contrarily, for applications involving food analysis, HPLC, GC, SFC, and CE in conjunction with an MS detector offer sensitive, picky, and repeatable procedures. SFC-MS assists in the study of thermally unstable and nonvolatile food components that are challenging to analyze by GC-MS, whereas GC-MS is specifically appropriate to the analysis of volatile organic compounds in food and food products. SFC-MS, on the other hand, makes it more difficult to analyze polar molecules. The use of HPLC-MS ensures various benefits, including extraction processes that are completed more quickly and with less effort. Additionally, the capacity of HPLC-MS can recognize and quantify a wider variety of polar, semipolar, and non-polar food components with a broad range of molecular sizes enable this method to outperform GC-MS or SFC-MS. Furthermore, peptide masses may overlap even when utilizing a high-resolution mass spectrometer when doing proteome analysis on complex dietary samples, which is where LC-MS/MS is most frequently used. For the quick and extremely accurate separation of ionic, weakly ionic and strongly polar substances, electromigration techniques like CE-MS are particularly well suited. Low cost, quick analysis, and minimal sample and reagent usage are the key benefits. It is environmentally favorable because there is a reduction in the use of organic solvents. The fundamental disadvantage of CEUV detectors is their low sensitivity; however, sensitivity can be increased by CE-MS coupling. Moreover, preconcentration methods and high-resolution mass spectrometry can be used to further increase the sensitivity of CEMS. However, LC-MS or GC-MS platforms are more reliable and stable than CE-MS platforms. [42]

- 5. Glycoprotein Analysis by LC-EIS-MS:** Mass spectrometry (MS) has evolved as the method of choice for proteomics and related research areas such as glycemic and glycoproteomics because of its speed, high sensitivity, accuracy and suitability for automation. Various mass analysers and ionization/fragmentation techniques are

available, providing high versatility in analysing a wide range of biomolecules in diverse contexts. [43]

- 6. Coupling of Liquid Chromatography with Mass Spectrometry as Interface Technique:** HPLC-MS coupling became a success story with the introduction of the so-called atmospheric pressure ionization (API) interfaces some 10 years ago. With API interfaces the eluent of the HPLC is evaporated outside the mass spectrometer. The analyte is also ionized outside the spectrometer at atmospheric pressure and only the ions generated are introduced into the mass spectrometer so that no huge gas freight has to be pumped off. As a result, mass spectrometric detectors can now easily be combined with liquid chromatographic separations. The most widely used interface technique is electrospray ionization (ESI) followed by atmospheric pressure chemical ionization (APCI) [44]
- 7. Drug Discovery:** Nuclear magnetic resonance (NMR) is one of the most specialized analytical techniques for this purpose, as it is crucial for identifying a drug and determining its structural composition. In the discovery and development of drugs, quantitative ^1H NMR spectroscopy. It covers the principles of quantitative NMR (qNMR), the physiochemical characteristics that affect qNMR, and the newest quantification referencing approaches. It is elaborated on the precise use of qNMR at many stages of drug discovery and development, including studies on natural products, dosage form quantitation, drug metabolism, and impurity profiling and solubility assessments. Because NMR tests are non-destructive, adaptable, and robust with high intra- and inter-subject variability, they are used in the drug discovery and development process.

The identification of a drug and its structural determination is the most important step in the process of the drug discovery and for this, nuclear magnetic resonance (NMR) is one of the most selective analytical techniques. Quantitative ^1H NMR spectroscopy in drug discovery and development. It deals with the fundamentals of quantitative NMR (qNMR), the physiochemical properties affecting qNMR, and the latest referencing techniques used for quantification. The precise application of qNMR during various stages of drug discovery and development, namely natural product research, drug quantitation in dosage forms, drug metabolism studies, and impurity profiling and solubility measurements is elaborated. NMR experiments are used for drug discovery and development processes as it is a non-destructive, versatile and robust technique with high intra and interpersonal variability High-throughput screening and structure-based drug discovery are the main methods used to find new therapeutic drugs, and MR techniques are the key to this process.

Compared to other approaches, which typically require real reference standards for measurement, NMR-based procedures are simpler and faster. [45]

The exact use of the quantitative ^1H NMR technology can be made for a variety of medication formulation and purification processes. Quick quantitative measurements during API (active pharmaceutical ingredient) development of a drug candidate can be provided by ^1H NMR approaches. NMR has recently been able to contribute to the clinical validation stage of drug development thanks to the expansion of qNMR into the investigation of the metabolome. [46]

- 8. Identification of Functional Group:** Functional groups in pharmaceutical compounds can be identified by variety of methods utilizing GC in conjunction with IR and UV detectors. Prior to the development of FTIR instruments, which are quick, functional group identification was done using GC-IR. In this instance, a sample that was injected into the GC after being separated using a column is deposited on a salt window in the IR instrument, causing the functional groups in the sample to absorb IR light. This uses infrared spectroscopy as a separation method, then identification, similar to GC-MS. [47]
- 9. In Clinical Toxicology:** Clinical toxicology benefits from the use of GC due to the creation of molecular ions, the availability of a wider variety of substances that may be analyzed, its high sensitivity, and faster analysis. Supersonic GC-MS is frequently used in clinical toxicology. In some circumstances, this is also used to confirm or reject LC-MS analysis findings. This technique is typically used to identify and measure toxins and venoms. [48]
- 10. Analysis of Drugs of Abuse:** GC-MS: A good analytical instrument for the analysis of illicit drugs is Headspace combined. Analyzing amphetamines and their metabolites in urine and determining the amount of nicotine in prescription medicines are examples of this type of analysis. In SIM mode, GC-MS with chemical ionization and traditional headspace will provide greater sensitivity by roughly 20 times. It is simpler to compare discovered chemicals with library data thanks to GC MS's consistent ionization [49,50]
- 11. In Fingerprint Analysis:** Chromatography is a physical method of separating mixtures of chemicals, such as those found in the herbal extract of herbal medicine (HM), into a variety of pure constituents or relatively straightforward sub-fractions. For the purpose of analyzing HM's fingerprints, chromatographic methods such as liquid chromatography (LC), gas chromatography (GC), thin layer chromatography (TLC), capillary electrophoresis (CE), etc. were used. The most often used technique is LC hyphenated techniques, which have the traits of wide applicability, high resolution, selectivity, sensitivity, and fully automatable operation. The biggest benefit of LC is the ability to choose detector arrays based on the chemical or physical characteristics of target substances. Additionally, to obtain more fingerprint details from a complicated biological material, the multi-wavelength combination of high-performance liquid chromatography-diode array detection (HPLC-DAD) and the data fusion of complementary detectors were discovered in several studies. [51]

IV. ADVANTAGES OF HYPHENATED TECHNIQUES

1. It is use for fast and precise analysis
2. Higher degree of automation
3. Higher sample throughput
4. It has better reproducibility
5. By using hyphenated technique separation and quantification attained at same time
6. It decreases the contamination due to its closed system [52]

V. DISADVANTAGES OF HYPHENATED TECHNIQUES

1. GC-MS not suitable for non-volatile and thermo unstable compound. It required derivatization depending on the type of molecule that are analyzed and derivatization can mask the result
2. Fragmentation pattern in LC-MS are poorly reproducible, therefore the database are problematic, the entire compound in plant extract will ionize under the same condition.
3. Most important disadvantage of LC-NMR is that it took longer time for experimental work. It also include the use of duteriated solvent which has partial use, there is difficulty in solvent selection
4. The LC-NMR technique involving high cost also the high equipment cost.
5. Skilled professional required therefore there is a requirement of operator training. [53]

VI. CONCLUSION

A hyphenated technique is a combination (or) coupling of two different analytical techniques with the help of proper interface. Hyphenated techniques combine the power of separation and quantification for more in-depth analysis, in turn solving more complex problems. A variety of double and triple hyphenated techniques, including LC-MS, LC-NMR, LC-IR, LC-ESI-MS, and LC-NMR-MS, have been utilized because of their several benefits, including increased sample throughput, higher levels of automation and separation reproducibility, quicker analysis, and simultaneous quantification. The significant advancements in hyphenated analytical methods over the last two decades have greatly expanded their applications in the analysis of biomaterials, especially natural products.

VII. ACKNOWLEDGEMENT

The authors wish to thank the Principal and Management of Shree Sainath College of Pharmacy, Nagpur, India for providing opportunity for this book chapter.

REFERENCES

- [1] O.S. Nwozo, E. M. Effiong, P. M. Aja, and C. G. Awuchi, "Antioxidant, phytochemical, and therapeutic properties of medicinal plants: A review," *International Journal of Food Properties*, vol. 26, pp. 359-388, December 2023.
- [2] T. Girase, J. Patil, A. Tatiya, D. Patil, and M. Patil, "Clomiphene Citrate as Nanomedicine Assistance in Ovulatory Disorders and Its Hyphenated Techniques," *Materials Proceedings*, vol. 14, pp. 6, May 2023.
- [3] K.N. Patel, J.K. Patel, M.P. Patel, G.C. Rajput, and H.A. Patel, "Introduction to hyphenated techniques and their applications in pharmacy," *Pharmaceutical methods*, vol. 1;1 pp. 2-13, October 2010.
- [4] D.L. Norwood, J.O. Mullis, and T.N. Feinberg, "7 Hyphenated techniques. In *Separation Science and Technology*," Academic Press, Vol. 8, pp. 189-235, January 2007.
- [5] [5] K.S. Raju, and D.N. Kumar, "Review of approaches for selection and ensembling of GCMs," *Journal of Water and Climate Change*, vol. 11, pp. 577-599 September 2020.
- [6] P. J. Sellers, D. A. Randall, G. J. Collatz, J. A. Berry, C. B. Field, and G. D. Collelo, "A revised land surface parameterization (SiB2) for atmospheric GCMs. Part I: Model formulation," *Journal of climate*, vol. 9, pp. 676-705, April 1996.
- [7] Y. Xu, "From GCMs to river flow: a review of downscaling methods and hydrologic modelling approaches," *Progress in physical Geography*, vol. 23, pp. 229-249, June 1999.
- [8] B. Steil, M. Dameris, C. Brühl, P.J. Crutzen, V. Grewe, M. Ponater, and R. Sausen. "Development of a chemistry module for GCMs: first results of a multiannual integration," *In Annales Geophysicae*, vol. 16, pp. 205-228, February 1998.

- [9] B. Niemann, S. K. Atreya, S. J. Bauer, G. R. Carignan, J. E. Demick, and R. L. Frost, "The abundances of constituents of Titan's atmosphere from the GCMS instrument on the Huygens probe," *Nature*. Vol. 438, pp. 779-784, December 2005.
- [10] V. K. Arora, and G. J. Boer, "A variable velocity flow routing algorithm for GCMS," *Journal of Geophysical Research: Atmospheres*. Vol. 104, pp. 30965-30979, December 1999.
- [11] D.J. Beale, F.R. Pinu, K.A. Kouremenos, M.M. Poojary, V.K. Narayana, B.A. Boughton, K. Kanojia, S. Dayalan, O.A. Jones, and D.A. Dias, "Review of recent developments in GC-MS approaches to metabolomics-based research," *Metabolomics*, vol. 14, pp. 1-31 November 2018.
- [12] S.Z. Hussain, and K. Maqbool, "GC-MS: Principle, Technique and its application in Food Science," *International Journal of Current Science*, vol. 13, pp. 116-126, March 2014.
- [13] H.J. Hübschmann, "Handbook of GC-MS: fundamentals and applications," John Wiley & Sons, July 2015.
- [14] M.S. Lee, and E.H. Kerns, "LC/MS applications in drug development Mass spectrometry reviews" vol.18, pp. 187-279. 1999
- [15] C.K. Lim, and G. Lord, "Current developments in LC-MS for pharmaceutical analysis," *Biological and Pharmaceutical Bulletin*, vol. 25, pp. 547-557, 2002
- [16] S.K. Grebe, and R.J. Singh, "LC-MS/MS in the clinical laboratory—where to from here?," *The Clinical biochemist reviews*, vol.32, pp.5, February 2011.
- [17] B. Zhou, J.F. Xiao, L. Tuli, and H.W. Ransom, "LC-MS-based metabolomics," *Molecular BioSystems*, vol. 8, pp. 470-481, 2012.
- [18] Poletti, editor, "Applications of LC-MS in Toxicology," Pharmaceutical Press, 2006.
- [19] J. Kuligowski, G. Quintas, S. Garrigues, B. Lendl, and de La. M. Guardia, "Recent advances in on-line liquid chromatography -infrared spectrometry (LC-IR)," *TrAC Trends in Analytical Chemistry*, vol. 29, pp. 544-552, Jun 2010.
- [20] G.W. Somsen, T. Visser, "Liquid chromatography/infrared spectroscopy Applications, Theory and Instrumentation," *Encyclopedia of Analytical Chemistry: Applications*, September 2006.
- [21] J. H. Arndt, S. S. Bhati, M. E. Cangussu, G. Geertz, H. Mohammadi, and R. Brüll, "Unraveling the comonomer distribution in ethylene-vinyl ester terpolymers through liquid chromatography with infrared detection. *Journal of Chromatography A*. 2023 Jul 4:464197.
- [22] J. Geiger, E. H. Korte, and W. Schrader, "Development of a simple gradient LC-IR interface for the detection of terpenoids from the α -pinene-ozone reaction," *Journal of Chromatography A*, vol. 922, pp. 99-110, July 2001.
- [23] P.R. Griffiths, "Recent applications of fourier transform infrared spectrometry in chemical and environmental analysis, *Applied spectroscopy*. Vol. 31, pp. 497-505, November 1977.
- [24] T.M. Kalyankar, A.C. Jadhav, and S.M. Mhetre, "Recent Advances in Coupling Technology in Analysis of Natural Product," *Research Journal of Pharmacy and Technology*, vol. 5, pp. 1145-1153, 2012.
- [25] V. Exarchou, M. Krucker, T.A. van Beek, J. Vervoort, I.P. Gerothanassis, and K. Albert, "LC-NMR coupling technology: recent advancements and applications in natural products analysis," *Magnetic Resonance in Chemistry*, vol. 43, pp. 681-700, September 2005.
- [26] O. Corcoran, and M. Spraul, "LC-NMR-MS in drug discovery," *Drug discovery today*, vol. 8, pp. 624-631, July 2003.
- [27] J. L. Wolfender, K. Ndjoko, and K. Hostettmann, "The potential of LC-NMR in phytochemical analysis." *An International Journal of Plant Chemical and Biochemical Techniques*, vol. 12, pp. 2-2, Jan 2001.
- [28] M.V. Elipe, "LC-NMR and other hyphenated NMR techniques," overview and applications.
- [29] F.C. Stintzing, J. Conrad, I. Klaiber, U. Beifuss, and R. Carle, "Structural investigations on betacyanin pigments by LC NMR and 2D NMR spectroscopy," *Phytochemistry*, vol. 65, pp. 415-422, February 2004
- .Y. Lin, S. Schiavo, J. Orjala, P. Vouros, and R. Kautz, "Microscale LC-MS-NMR platform applied to the identification of active cyanobacterial metabolites," *Anal Chem*, vol. 80, pp. 8045-8054, 2008.
- [30] F. Duarte, M. Godejohann, U. Braumann, M. Spraul, and A. M. Gil, "Application of NMR spectroscopy and LC-NMR/MS to the identification of carbohydrates in beer," *Journal of agricultural and food chemistry*, vol. 51, pp. 4847-4852, August 2003.
- [31] S. Bajad, M. Coumar, R. Khajuria, O. P. Suri, and K. L. Bedi, "Characterization of a new rat urinary metabolite of piperine by LC/NMR/MS studies," *European journal of pharmaceutical sciences*, vol. 19, pp. 413-421, August 2003.
- [32] Z. Sun, H. Sun, H. Li, J. You, and L. Xia, "A review on differential isotope-coded derivatization reagents for LC-API-MS analyses," *Current Analytical Chemistry*, vol. 10, pp. 381-392, July 2014.

- [33] A. Imrie, "LC-API/MS in Drug Metabolism and Pharmacokinetic Studies" (Doctoral dissertation, University of Sunderland).
- [34] Stadlmann, M. Pabst, D. Kolarich, R. Kunert, and F. Altmann, "Analysis of immunoglobulin glycosylation by LC-ESI-MS of glycopeptides and oligosaccharides," *Proteomics*, vol. 8, pp. 2858-2871, July 2008.
- [35] B. Meermann, and M. Sperling, "Hyphenated techniques as tools for speciation analysis of metal-based pharmaceuticals: developments and applications," *Analytical and bioanalytical chemistry*, vol. 403, pp. 1501-1522, June 2012.
- [36] Masike, M.A. Stander, and A. de Villiers, "Recent applications of ion mobility spectrometry in natural product research" *Journal of Pharmaceutical and Biomedical Analysis*, vol. 195, pp. 113846, February.
- [37] Bhavyasri, K. Sindhu, and D. Rambabu, "A Review: Liquid Chromatography-Nuclear Magnetic Resonance Spectroscopy (LC-NMR) and Its Applications," *IOSR Journal of Pharmacy*, vol. 9, pp. 54-62, 2019.
- [38] A. Medina, E. V. Maciel, A. L. de Toffoli, and F. M. Lanças, "Miniaturization of liquid chromatography coupled to mass spectrometry.: 2. Achievements on modern instrumentation for miniaturized liquid chromatography coupled to mass spectrometry," *TrAC Trends in Analytical Chemistry*, vol. 128, pp. 115910, July 2020.
- [39] J. L. Wolfender, E. F. Queiroz, and K. Hostettmann, "The importance of hyphenated techniques in the discovery of new lead compounds from nature," *Expert opinion on drug discovery*, vol. 1, pp. 237-260, August 2006.
- [40] Y. Li, Y. Shen, C. L. Yao, D. A. Guo, "Quality assessment of herbal medicines based on chemical fingerprints combined with chemometrics approach: A review," *Journal of Pharmaceutical and Biomedical Analysis*, vol. 185, pp. 113215, June 2020.
- [41] P. Baviskar, D. V. Jain, S. D. Pingale, S. S. Wagh, S. P. Gangurde, S. A. Shardul, A. R. Dahale, and K. S. Jain, "A Review on Hyphenated Techniques in Analytical Chemistry," *Current Analytical Chemistry*, vol. 18, pp. 956-976, November 2022.
- [42] C. G. Awuchi, and H. Twinomuhwezi, "Hyphenated techniques," In *Analytical Techniques in Biosciences*, pp. 125-145, January 2022.
- [43] S. Krishnamurthy, R. Kadu, "A comparative review on detection of Cocaine using hyphenated techniques" *Chemical Papers*, vol. 1, pp. 1-3, April 2022.
- [44] C. Lozano, H. E. Jones, M. P. Barrow, and M. Wills, "Chemoselective derivatisation and ultrahigh resolution mass spectrometry for the determination of hydroxyl functional groups within complex bio-oils," *RSC advances*, vol. 13, pp. 17727-17741, 2023.
- [45] B. Sharma, and D. K. Yadav, "Chromatographic and their hyphenated techniques in quality-based standardization of medicinal plants: Current scenario and future perspectives," *South African Journal of Botany*, vol. 157, pp. 467-483, June 2023.
- [46] J. Hubert, J. M. Nuzillard, and J. H. Renault, "Dereplication strategies in natural product research: How many tools and methodologies behind the same concept?," *Phytochemistry Reviews*, vol. 16, pp. 55-95, February 2017.
- [47] R. Siddiqui, Z. A. AlOthman, and N. Rahman, "Analytical techniques in pharmaceutical analysis: A review," *Arabian Journal of chemistry*, vol. 10, pp. S1409-1421, February 2017.
- [48] Sdrigotti, M. Collard, and G. Purcaro, "Evolution of hyphenated techniques for mineral oil analysis in food," *Journal of Separation Science.*, vol. 44, pp. 464-482, January 2021.
- [49] Song, R. Zhu, Z. T. Hammoud, and Y. Mechref, "LC-MS/MS quantitation of esophagus disease blood serum glycoproteins by enrichment with hydrazide chemistry and lectin affinity chromatography," *Journal of proteome research*, vol.13, pp. 4808-4820, November 2014.
- [50] S. Kumar, and M. J. Bogusz, "Hyphenated techniques in liquid chromatography and their applications in forensic toxicology: A review," *Journal of Forensic Science and Medicine*, vol 7, pp. 123-136, October 2021.
- [51] S. Singh, and R. Roy, "The application of absolute quantitative ^1H NMR spectroscopy in drug discovery and development. *Expert Opinion on Drug Discovery.*" Vol. 11, pp. 695-706, July 2016.
- [52] Zhang, T. Li J, Zhu, D. Gu Q, Li, "Advanced tools in marine natural drug discovery," *Current opinion in biotechnology*, vol. 42, pp. 13-23, December 2016.