

GENDER AND AGE AUTHENTICATION AND CLASSIFICATION USING FINGERPRINT

Abstract

In today's technological advanced scenario, search for physical fingerprint evidence of a suspect to crime by the forensic investigators is an outdated method. The image is enhanced using Contourlet Based Transform (CNT). Here we use, Singular Value Decomposition (SVD), Principal Component Analysis (PCA) and Discrete Wavelet Transform (DWT) have all been used to extract features from a person's fingerprint in order to estimate their age and gender for authentication, behavior analysis etc. For categorization, K nearest neighbour (KNN) is considered. Using a real-time database of male and female fingerprints, the system is evaluated. The five categories of tested fingerprints are: up to 12, 13–18, 19–24, 25–35, and 36 and above. Both male and female values are drawn from the sample database. Determine if it belongs to a male or female and the associated age is the goal of this paper.

Keywords: Contourlet Based Transform, k nearest neighbor, Fingerprint, Gender Classification, Principle Component Analysis, Singular Value Decomposition, Discrete Wavelet Transform.

Authors

D Sheefa Ruby Grace

Assistant Professor
Department of Computer Science
Sarah Tucker College
Tirunelveli, Tamil Nadu, India.
sheefacs@sarahtuckercollege.edu.in

Jai Ruby

Assistant Professor
Department of Computer Applications and
Research Centre
Sarah Tucker College
Tirunelveli, Tamil Nadu, India.
jrubbyeval@gmail.com

N Subathra

Assistant Professor
Department of Computer Science
Sarah Tucker College
Tirunelveli, Tamil Nadu, India.
subathrac@sarahtuckercollege.edu.in

I. INTRODUCTION

Using digital computers for enhancing photo images is known as digital image processing. The image is processed in a number of methods during digital image processing, object recognition is also included in the process. The act of giving an object a name (such as "vehicle") based on its descriptors is known as recognition. Many facets of the human body have been used to determine sex and gender. Recent examples include the ratio of the foot to the shoe dimensions, the number of metatarsals, the humerus, the length of the radial and ulnar bones, the patella, the teeth etc. Humans are uniquely identified by means of biometric identification technologies, mostly for identification and verification.

Due to their uniqueness and ability to remain constant across an individual's lifetime, fingerprints have been utilized for the identification of age and gender[1]. In order to generate investigative leads for locating elusive individuals, gender and age information is crucial. It's crucial to offer information about the gender and age of potential suspects as well as any other relevant details. The classification of gender and age gives a lot of insights about the characteristics of male and female that can be applied over various applications of human computer interaction or psychological analysis. For gender and age authentication and classification various techniques can be employed. For an image, the spatial distortions are well handled by transform domain approaches such as Discrete Wavelet Transform (DWT), Laplacian Pyramid Transform (LPT), Curvelet Transform (CT) and Contourlet Transform (CNT) etc.

In this study, DWT, SVD, and PCA are used to extract a person's gender and age from their fingerprint. No two people, not even identical twins, have ridge patterns on their finger pads that are exactly alike. The literature shows, the major skin ridges (ridge counts) that make up a fingerprint are created during weeks 12 through 19 of pregnancy, and the resulting fingerprint ridge configuration (fingerprint) is then established forever [2-3]. Furthermore, there is a significant amount of variation in epidermal ridge breadth in people [4]. Statistics show that dermatoglyphic characteristics differ by gender, ethnicity, and age groups [5]. Numerous researchers have established that a fingerprint may be analysed to determine a person's sex [6–11]. The method of gender categorization using KNN based on CNT, DWT, SVD, and PCA is shown in Figure 1.

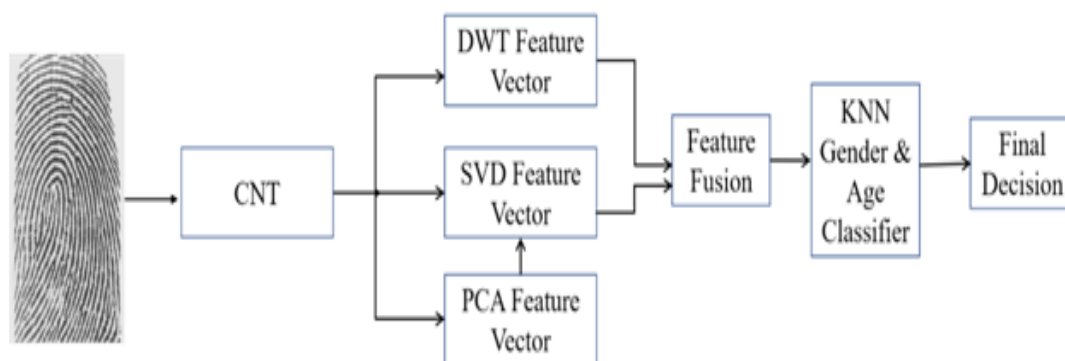

Figure 1: Process for Gender and Age Classification System

A discrete image framework called contourlet transform is used to identify discontinuities at object edges. Wavelet transform approach is a method of transformation. It offers the depiction of time and frequency. In this study, the discrete wavelet transform was utilised to classify gender and age. SVD (Singular Value Decomposition) and PCA (Principal Component Analysis) techniques are used for feature extraction.

The remainder of this paper flows as follows. The Literature Survey on Gender Classification is reviewed in Section 2. Preprocessing is done in Section 3. Followed by feature extraction in Section 4. Experimental setup and result are discussed in Section 5.

II. LITERATURE SURVEY

The ridge density is greater for females than males, according to earlier research on classification of gender based on the ridge density [7,8,9,10,11]. It is made clear that mean ridge counts of males are found to be more than females. Analyzed is a novel method of identification that makes use of simultaneously captured images of the surface and vein of the finger. In order to combine the matching scores for finger vein and finger texture, this research studies a combination of methodologies that include nonlinear fusion [12]. Using solely DWT and SVD, a novel approach for gender classification of fingerprint pictures has been developed [13]. A person's identity is verified using their fingerprint biometric. It is suggested to identify domains based on their transform fingerprints. The Fingerprint has been preprocessed to a size that is appropriate for DTCWT. Applying DTCWT at various degrees results in the fingerprint traits.[14].

III. IMAGE ACQUISITION

Data gathering from multiple imaging modalities is a crucial task for any system area. Picture acquisition, the first stage of any image processing task, is acquiring original input image data from the original source. The use of image acquisition is very flexible.

1. Image Preprocessing

- **Noise Removal:** The purpose of preprocessing the datasets is to make them machine readable and to improve the image quality by eliminating noise. Noise is the term for variations in brightness or intensity in an image. It could be added during the addition of the photographs if the camera flash, the lighting, or the image's background noise all change. The goal of image pre-processing is to eliminate noise from the image in order to improve the input image's quality, obtain the most accurate results possible, and increase effectiveness.
- **Normalization :** The essential preprocessing step of normalisation decreases the colour and intensity variances found in tainted images from various sources. Research from the last 20 years has shown that normalisation greatly improves the accuracy of the unseen dataset by about 8% [16]. The study images were from a preexisting dataset for laboratory analysis. The smear slides are made in the lab using multiple chemical stains, which causes colour variance because different chemicals are used and different staining techniques are used. The model's ability to learn and deal with more complicated models with a variety of images is hampered, which increases the

mistake rate. A solution to standardize this is normalization. By converting the input data to a common space, the Stain Normalisation preprocessing technique aims to reduce colour variability and enhance algorithm generalisation. No matter the scanning technology, stain vendor, or preparation procedures are mapped to equivalent colour attributes in stain normalised digital pathology samples. Stain Normalisation has shown improvement in computer-assisted diagnostic tools due to the decreased variability in tissue colour features [17, 18, 19]. In their article, Cimopi et al. [15] have shown how methods like histopathology [20] and normalization can improve the classification of colorectal tissues in colorectal cancer [10].

- 2. Contourlet Transform:** The wavelet transform excels at identifying discontinuities at object edges but fails to pick up on edge smoothness. Additionally, it can only record a limited amount of directional data. The shortcomings of wavelet can be successfully overcome via contourlet transformation. A discrete image framework with several scales and directions is called a contourlet transform.

The multi-scale analysis and the multi-direction analysis are separated serially in this transform. The smooth contours of images are obtained using the universal contourlet transform using a double filter bank architecture. In this double filter bank, the Laplacian pyramid (LP) is used to initially capture the point discontinuities and the directional filter bank (DFB) is used to convert them into linear structures.

The Laplacian pyramid (LP) decomposition only produces one band-pass image in a multidimensional signal processing that can avoid frequency scrambling. Additionally, directional filter banks (DFB) are only appropriate for high frequency applications since they leak low frequency signals in their directional sub-bands. As a result, DFB and LP are integrated using low frequency reduction and multiscale decomposition. picture signals flow through LP sub-bands in order to obtain band-pass signals and transfer those signals through DFB to collect the directional information of the picture [21]. Wavelet transform is less precise than contourlet transform when working with curves.

It's a makeover that decomposes a given signal into a number of sets, where each set is a time series of portions describing the time elaboration of the signal in the corresponding frequency band. The smooth contours of a picture are obtained via the contourlet transform, which employs a double filter bank construction.

Steps for Image Enhancement

- Input : Real Time Fingerprint Images
- Output: Enhanced preprocessed images
 - Read the images from the Dataset
 - Remove the noise from the images
 - Apply Normalisation
 - Apply CNT

3. Finger Print Feature Extraction: The essential requirement for any pattern recognition is feature extraction. We employed the DWT, SVD, and PCA algorithms for feature extraction. The next section discusses these methods.

4. Feature Extraction using DWT: A data vector with a length that is an integer power of two can be transformed into a new vector with the same length using the DWT linear operation. It is a tool that divides data into various frequency components and analyses each one with resolution that is appropriate for its scale. Decompose the image using a 2D wavelet transform into subbands. That is High-Low, High-High, Low-Low, and Low-High. The majority of the energy was low frequency. Low-Low energy band is used for breakdown since it provides more information. Equation (1) is used to compute the energy of each subband.

$$E_k = \frac{1}{HW} \sum_{i=1}^H \sum_{j=1}^W |x_k(i,j)| \dots(1)$$

$X_k(i,j)$ → represents pixel of k^{th} subband.

H,W → represents subbands' height and width

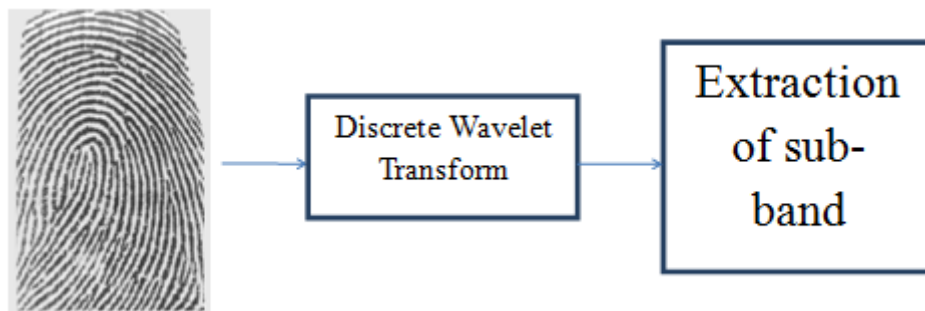

Figure 2: Feature Extraction using DWT

5. Feature Extraction using SVD: A rectangular C by R matrix B has a Singular Value Decomposition(SVD) into the product of an C by R orthogonal matrix O, a R by R diagonal matrix of singular value V and the transpose of a R by R orthogonal square matrix W,

$$B = O V W^T$$

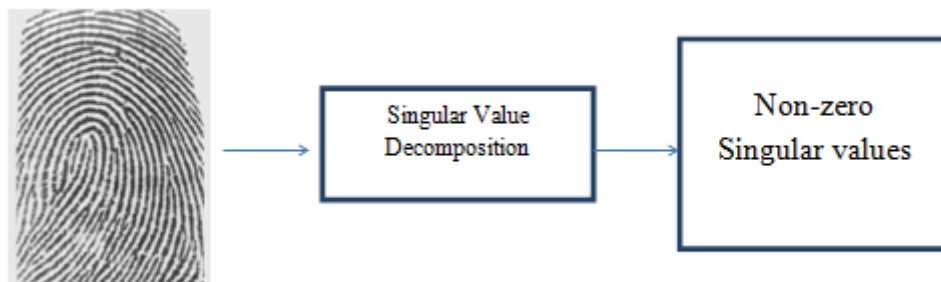

Figure 3: SVD based Feature Extraction.

Eigen vector(V) is calculated using the equation(2)

$$[O \ V \ W^A T] = \text{SVD}(Z) \quad \text{----- (2)}$$

- 6. Feature Extraction using PCA:** The principal components, the features, are orthogonal to one another and result in orthogonal weights. For high dimensional data, PCA is fantastic.

```
[V E] = eig( cov(Z) );
[E order] = sort(diag(E), 'descend');
V = V(:,order);
```

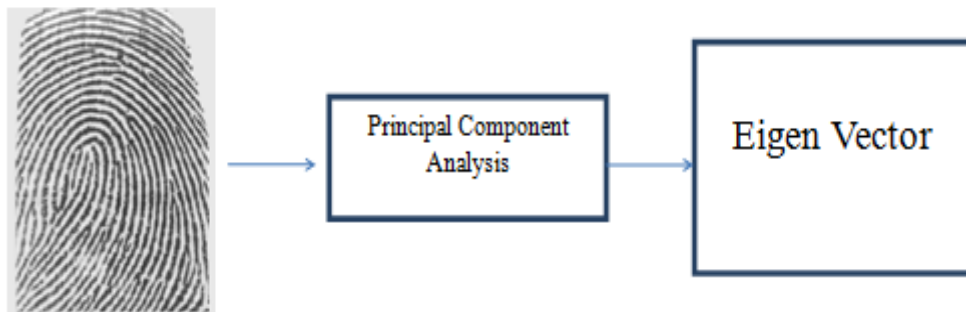

Figure 4: Feature Extraction using PCA

The major components are represented by the covariance matrix's eigenvectors V , and the variance explained is shown by the associated eigenvalues E .

- 7. Fusion:** Due of the strong relationship between the two techniques, the features retrieved using principal component analysis are integrated with singular value decomposition. To create the feature vector for the training images, combine the Eigen Vectors, subband energy vector (E), and feature vectors. The subband energy vector size, for instance, is generated based on the levels selected and is 500×1 if the image size is 550×500 . The resultant feature vector is 500×1 , depending on the DWT levels that were used.

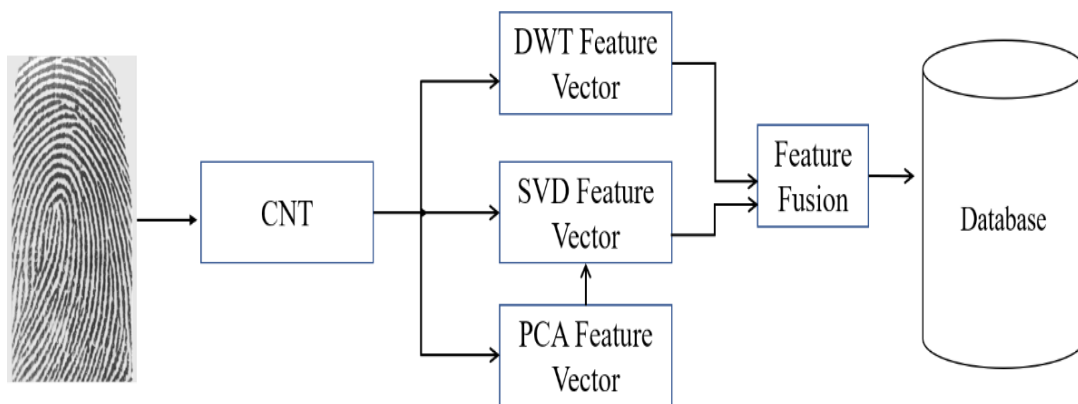

Figure 5: Gender and Age Classification System

The distinctive fingerprint characteristics that will be used for identification are contained in the feature vector. A reference vector is kept that contains the feature vectors for every image in the training set. The resultant vector is created with 'n' rows, each row representing the feature vector of a training image if the training set contains 'n' images. For reference during classification, the number of columns reflects each distinct characteristic of the image vector. The pictures are arranged in groups of 1 to 10.

Table 1: Sample wise Details for Gender and Age

Gender	Age Group	Group
M	36 and above	10
M	25-35	9
M	19-24	8
M	13-18	7
M	Upto 12	6
F	36 and above	5
F	25-35	4
F	19-24	3
F	13-18	2
F	Upto 12	1

- 8. KNN Classifier:** KNN categorises the test image using the learned vector saved. The training set and the grouping created in the previous phase are used to classify the photos.

In order to categorise objects in the feature space using closet training samples, K nearest neighbours are utilised. The following is the KNN classification function.

Class=KNNCLASSIFY(S,T,G)

S → Image used for Testing

T → Trained images

G → Distinct Vector defining the group

9. Classification Algorithm

- Input : feature database and unidentified images
- Output : The class of the image to which the unknown image is assigned
 - Decomposition using DWT at various levels.
 - Sub band energy vector (E) is calculated at each level using (2)
 - Non zero singular values are extracted using SVD
 - Eigen Vector for PCA(V1) is calculated using (3)
 - Fuse the result of PCA and SVD
 - Generate the feature vector by combining E,V and V1
 - Classify unidentified image using KNN

IV. EXPERIMENTAL RESULT

1. **Data Set:** Using a fingerprint scanner called the Digital Persona 4100, the internal database's fingerprint images were gathered. 200 hand thumb impressions from men and women of various ages are included in the database. The database consists of gray scale fingerprint images. The size of the image is 100 x 110. The number of female fingerprint images is greater than the number of male fingerprint images. For the experiments we considered only thumb finger, middle finger and pointing finger at the finger scanning device could not sense the ring finger and the little finger accurately.

The images are classified into various groups as specified in Table 2 and 3.

Table 2: Accuracy of Gender and Age Classification using CNT, DWT, PCA and SVD for Female

Gender & Age Group	Left Hand			Right Hand		
	Thumb Finger	Pointing Finger	Middle Finger	Thumb Finger	Pointing Finger	Middle Finger
F UPTO 12	60	70	80	70	80	70
F 13- 19	80	60	80	60	80	60
F 20 – 25	60	70	70	70	70	70
F 26 – 35	80	60	70	60	70	70
F 36 & above	80	80	80	80	80	70

Table 3: Accuracy of Gender and Age Classification using CNT, DWT, PCA and SVD for Male

Gender & Age Group	Left Hand			Right Hand		
	Thumb Finger	Pointing Finger	Middle Finger	Thumb Finger	Pointing Finger	Middle Finger
M UPTO 12	70	70	80	70	80	70
M 13- 19	80	60	80	60	80	70
M 20 – 25	80	70	70	70	70	60
M 26 – 35	60	60	70	60	70	60
M 36 & above	80	80	80	80	80	70

The above table 2 and table 3 shows the classification accuracy of female and male for the fingerprint of thumb finger, pointing finger and middle finger for different age group using KNN classifier. The result shows that the right thumb fingerprint is better

for female identification and left hand middle fingerprint shows the better result for male identification. Regarding the age group classification, the group 5 (i.e) F 36 & above and group 10 (i.e) M 36 & above shows better accuracy than other groups. This clearly shows that the right thumb finger of female and left middle finger of male with age group above 36 will give more accurate results than other groups.

V. CONCLUSION

In this study, we have put forth a technique for classifying the gender and age of fingerprints by contrasting the numerous features that CNT-extracted improved images possessed. SVD, DWT, and PCA algorithms are applied to extract the features. Gender classification is done using the KNN classifier. Both the adult male and female results are better. For females, the right thumbprint yields superior results, but for men, the left middle fingerprint does. As a future work, the student's academic performance can be examined using this gender and age classification. It can also be used to categorise transgender people.

REFERENCES

- [1] D. Maltoni, D. Maio, A. K. Jain, and S. Prabhakar, "Handbook of Fingerprint Recognition", first ed., Springer, New York, 2003.
- [2] J. John, Mulvihill, and David W. Smith, "The genesis of dermatoglyphics," the journal of pediatrics, vol. 75, no. 4, 1969, pp. 579-589.
- [3] W. Babler, "Embryologic development of epidermal ridges and their configurations," In: Plato CC, Garruto RM, Schaumann BA, editors.; Dermatoglyphics: Science in Transition.
- [4] Miroslav Kralik, Vladimir Novotny, "Epidermal Ridge Breadth: An Indicator of Age and Sex in Paleodermatoglyphics", Variability and Evolution, Vol. 11, 2003, pp. 5-30.
- [5] Harold Cummins, Walter J. Walts, and James T McQuitty, "The breadths of epidermal ridges on the finger tips and palms - A study of variation." American Journal of Anatomy, vol. 68, no.1, 1941, pp. 127-150.
- [6] M. Kralik and V. Novotny, "Epidermal ridge breadth: an indicator of age and sex in paleo dermatoglyphics Variability and Evolution," vol. 11, 2003, pp. 5-30.
- [7] M.D. Nithin, B. Manjunatha, D.S. Preethi, and B.M. Balaraj, "Gender differentiation by Finger ridge count among South Indian population," Journal of Forensic and Legal Medicine, vol. 18, no. 2, pp. 79-81, 2011.
- [8] Dr. Sudesh Gungadin MBBS, MD "Sex Determination from Fingerprint Ridge Density," Internet Journal of Medical Update, Vol. 2, No. 2, 2007.
- [9] G. G. Reddy, "Finger dermatoglyphics of the Bagathas of Araku Valley (A.P.), American Journal of Physical Anthropology, vol. 42, no. 2, 1975, pp. 225-228.
- [10] M. Acree, "Is there a gender difference in fingerprint ridge density?," Forensic Science International, vol. 102, no.1, 1999, pp.35-44.
- [11] D.Maio and D.Maltoni, "Ridge-line density estimation in digital images," in Proceedings of the 14th International Conference on Pattern Recognition (ICPR), 1998, pp. 534-538.
- [12] Ajay Kumar and Yingbo Zhou, "Human Identification using Finger Images," IEEE Trans. Image Processing, vol.21, pp.2228-2244, April 2012.
- [13] Gnanasivam .P and Dr.Muttan .S, " Fingerprint Gender Classification and age estimation using Wavelet Transform and Singular Value Decomposition," International Journal of Biometrics and Bioinformatics (IJBB), Volume (6) : Issue (2) : 2012 .
- [14] Jossy P. George and Abhilash S. K., Raja K. B. , "Transform Domain Fingerprint Identification Based on DTCWT ," International Journal of Advanced Computer Science and Applications, Vol. 3, No. 1, 2012.
- [15] Francesco Ciompi, Oscar Geessink, Babak EhteshamiBejnordi, Gabriel Silva De Souza, Alexi Baidoshvili, Geert Litjens, Bram Van Ginneken, Iris Nagtegaal, and Jeroen Van Der Laak "The importance of stain normalization in colorectal tissue classification with convolutional networks" Technical report.
- [16] Andreea Anghel, Milos Stanisavljevic, Sonali Andani, Nikolaos Papandreou, Jan Hendrick Rüschoff, Peter Wild, Maria Gabrani, and Haralampos Pozidis. "A High-Performance System for Robust Stain Normalization of Whole-Slide Images in Histopathology", Frontiers in Medicine, 6, Sep 2019.

- [17] Adnan Mujahid Khan, Nasir Rajpoot, Darren Treanor, and Derek Magee. “A nonlinear mapping approach to stain normalization in digital histopathology images using image-specific color deconvolution”, IEEE Transactions on Biomedical Engineering, 61(6):1729–1738, 2014.
- [18] Babak EhteshamiBejnordi, Geert Litjens, Nadya Timofeeva, Irene Otte-Höller, André Homeyer, Nico Karssemeijer, and Jeroen A.W.M. Van Der Laak. “Stain specific standardization of whole-slide histopathological images”, IEEE Transactions on Medical Imaging, 35(2):404–415, feb 2016. 43
- [19] Neeraj Kumar, Ruchika Verma, Sanuj Sharma, Surabhi Bhargava, Abhishek Vahadane, and Amit Sethi. “A Dataset and a Technique for Generalized Nuclear Segmentation for Computational Pathology”, IEEE Transactions on Medical Imaging, 36(7):1550–1560, jul 2017.
- [20] Ubydul Haque, Syed Masud Ahmed, Shahed Hossain, Mamun Huda, Awlad Hossain, Mohammad Shafiul Alam, Dinesh Mondal, Wasif Ali Khan, Mohammad Khalequzzaman, and Rashidul Haque. “Malaria Prevalence in Endemic Districts of Bangladesh”, PLoS ONE, 4(8):e6737, aug 2009.
- [21] <https://en.wikipedia.org/wiki/Contourlet>