

# SOLUBILITY ENHANCEMENT TECHNIQUES FOR ENHANCING THE SOLUBILITY OF DAPSONE

## Abstract

Dapsone is antibacterial medication which is used in the treatment of leprosy and dermatological conditions like dermatitis herpetiformis. It belongs to a sulfones class of drugs. It belongs to class-2 drug of BCS which has low solubility and high permeability. The main aim of the study is to develop different formulations of dapsone to increase the solubility and bioavailability. The different techniques for improving, solvent evaporation method, fusion method, nanosuspension, Micronization . The prepared product was evaluated for drug content, solubility and melting point. The formulations are prepared by each technique. The formulations were developed by nanoprecipitation, micronisation, solvent evaporation and fusion method and nanosuspension technique. Out of the all formulations, optimised formulation prepared by nanoprecipitation exhibiting drug content of 88.3% and solubility has been increased to 96%. Optimised formulation prepared by solvent evaporation method exhibiting drug content of 90% and solubility has been increased to 102%. Optimised formulation prepared by fusion method exhibiting drug content of 113% and solubility has been increased to 116%. Optimised formulation prepared by micronisation method exhibiting drug content of 112% and solubility has been increased to 88%. Optimised formulation prepared by nanosuspension method exhibiting drug content of 100% and solubility has been increased to 92.5%.

**Keywords:** Nanoprecipitation, Solvent evaporation method, Fusion method, Nano suspension, Micronization

## Authors

### M. Usha

Bachelor  
Department of Pharmacy  
RBVRR Women's College of Pharmacy  
Meerpet, L.B Nagar, Hyderabad, India

### P. Sankeerthana

Bachelor  
Department of Pharmacy  
RBVRR Women's College of Pharmacy  
Meerpet, L.B Nagar, Hyderabad, India

### R. Jayasri

Bachelor  
Department of Pharmacy  
RBVRR Women's College of Pharmacy  
Meerpet, L.B Nagar, Hyderabad, India  
nihas62001@gmail.com

### S. Niharika

Bachelor  
Department of Pharmacy  
RBVRR Women's College of Pharmacy  
Meerpet, L.B Nagar, Hyderabad, India  
nihas62001@gmail.com

### S. Madhuri

Bachelor  
Department of Pharmacy  
RBVRR Women's College of Pharmacy  
Meerpet, L.B Nagar, Hyderabad, India

### Dr. A. Krishna Sailaja

Bachelor  
Department of Pharmacy  
RBVRR Women's College of Pharmacy  
Meerpet, L.B Nagar, Hyderabad, India

## I. INTRODUCTION

An important physicochemical property of drug substance is solubility, especially aqueous system solubility. To achieve therapeutic efficacy a drug should have a property of aqueous solubility. For drug to enter systemic circulation and exert a therapeutic effect it must be in a solution. Therefore, solubility defined as “concentration at which the solution phase is equilibrium with solute at a stated temperature and pressure”. Solubility is the property of a solute (solid, liquid or gaseous) to dissolve in a solvent (solid, liquid or gaseous) to form a homogeneous solution of the solute in the solvent. The solubility of a substance fundamentally depends on the solvent used, temperature and pressure.

If the solubility of drugs substance is less than desirable, consideration must be given to improve its solubility. The methods to accomplish this, depends on chemical nature of drug and type of drug product under consideration. Chemical modification of drug into salt or ester form are frequently used to increase solubility. A drugs solubility is usually determined by the equilibrium solubility method, by which an excess of drug is placed in solvent and shaken at constant temperature over a long period until equilibrium is obtained. Chemical analysis of drug contain in the solution is performed to determine degree of solubility. The extent of solubility of substance in a specific solvent is measured as the saturation concentration, where adding more solute does increase its concentration in the solution <sup>[1]</sup>.

Knowledge of the solubility of a drug is also important during manufacturing of solid dosage forms such as orally administered drugs, liquid dosage forms such as injectables and other dosage forms. Solubility enhancement remains one of the primary areas of focus during the formulation development phase, there are several situations that may require solubility reduction and enhancement. The extent of solubility ranges widely from infinitely soluble (fully miscible) such as ethanol in water, to poorly soluble, such as silver chloride in water. The term insoluble is often applied to poorly or very poorly soluble.

**Table 1:** Tabular form of Solubility criteria as per USP

Descriptive term	Part of solvent required per part of solvent
Very soluble	<1
Freely soluble	1-10
Soluble	10-30
Sparingly soluble	30-100
Slightly soluble	100-1000
Very slightly soluble	1000-10,000
Practically insoluble	10,000 and over

## II. IMPORTANCE OF SOLUBILITY

Solubility is one of the important parameters to achieve desired concentration of drug in systemic circulation for achieving required pharmacological response. Poorly water-soluble drugs often require high dose in order to reach therapeutic plasma concentrations after oral administration. The improvement of drug solubility there by its oral bioavailability remains one of the most challenging aspects of drug development process especially for oral

drug delivery system. There are numerous approaches available and reported literature to enhance the solubility of poorly water-soluble drugs.

In pharmaceutical field solubility parameters are primarily used to guide organic solvent selection co crystals and salt screening, lipid-based delivery, solid dispersions and nano or micro particulate drug delivery system. Enhance bioavailability of poorly soluble drugs (BCS class II, class IV) a new drug with pH dependent, poor solubility (< 10ug/ml) at intestinal pH and low medium permeability this results in poor drug bioavailability and precipitation in intestinal fluids. With the cryo-spraying technology it was possible to formulate the drug as solid dispersion into amphiphilic lipid based micro spheres to improve dissolution profile.

Controlled release of highly soluble BCS class I drugs. Metoclopramide is a highly soluble, highly absorbable drugs used to treat GI disorders and as antiemetic in chemotherapy treatment. Very bitter taste it is usually administered 3 to 4 times a day. Improve bioavailability of celecoxib. Celecoxib is considered in BCS class II drug which has Poor drug solubility leads to sporadic. As other cox 2i, its cardiovascular toxicity limits its wider therapeutic application. In pre-formulation studies, Solubility is an essential and extensively studied parameter. It focuses on drug solvent system that could occur in drug delivery system. In medicine, solubility plays a critical role in drug effectiveness. Without drug substance cannot be observed, leading to low bioavailability, poor solubility of drug lead to other issues such as challenges with metabolism or permeability, interactions with other drugs or the need to extend drug release. The negative effect of compounds with low solubility includes poor absorption and bioavailability, insufficient solubility for IV dosing, development challenges leading to increasing the development cost and time, burden shifted to patient.

Currently only 8% of new drug candidates have both high solubility and permeability. Nearly 40% of the new chemical entities currently being discovered are poorly water soluble. Any drug to be absorbed must be present must be present in the form of an aqueous solution at the site of absorption <sup>[1,2]</sup>.

### III. NANO-PARTICLES

These are defined as particle of matter ranging between 1 to 100nm in diameter. They are ultrafine particles; these are distinguished from microparticles by size ranges between 1 to 1000micrometer. These are taken in oral route by compressing the powder into the tablet as solid dosage form. These are usually observed in electron microscope or with laser. In the solution as they are smaller in sizes observed in wavelength of visible light <sup>[9]</sup>. They can easily pass through normal filter paper and some requires special nanofiltration technique. These nanoparticles are used in various sectors such as agriculture, automotive, construction, cosmetics, electronics, medicine, food, textile etc.

**1. Nanoprecipitation Technique:** The technique is used to produce nanoparticles is nanoprecipitation. This technique was first developed and patented by Fessi and his co-workers in 1989. It has numerous advantages and easy to prepare. The entire procedure is carried out in single step as it requires two solvents which are miscible. Both the polymer and drug must dissolve in first system (the solvent) not the second system (the non-solvent). Nanoprecipitation occurs by de solvation of polymer when added to non-solvent

results in nanoparticles. The rapid nanoparticle formation by Marangoni effect which is due to interfacial turbulences that take place at the interface of the solvent and the non-solvent and result from complex and cumulated phenomena such as flow, diffusion and surface tension variation. Nanoprecipitation method is most widely used for hydrophilic drugs. The nanoparticle is affected by the parameters of polymer concentration and surfactant concentration of solvent and non-solvent system respectively<sup>[7]</sup>.

- 2. Solid Dispersion:** Solid dispersion, defined as the dispersion of one or more pharmaceutical active ingredients (API) into a carrier at a solid state. The product of solid dispersion contains both hydrophilic and hydrophobic matrix. When drug and polymer in contact then drug occupies empty spaces in polymeric chains and thus drug is incorporated into carrier. Solid dispersions obtained as powder form which are compressed into solid dosage form. These are prepared by solvent and fusion methods. The selection of the procedure for preparing solid dispersion depends mainly upon interaction between drug and carrier. Carrier used in this method are polymers and the selection of carrier is an important parameter in preparation of solid dispersion, especially the carrier must be water soluble. Solid dispersion has better dissolution rate due to reduced particle size and increased particle porosity<sup>[16]</sup>.
- 3. Solvent Evaporation Method:** It is also called as solvent evaporation method. It is a technique in which physical mixture of API (drug) and the carrier is dissolved in the common solvent and is evaporated until a clear solvent solid mass is obtained and solid mass is further dried. In this method the drug and carrier are co-precipitated to form micro particles. The first step involved in the solvent evaporation method is solution preparation containing solvent and drug. The second step involves evaporation of solvent by heating a which result in the formation of solid dispersion of product. The molecular level mixing of drug and polymer occurs. Due to this optimum dissolution/solubility is achieved<sup>[17]</sup>.

In solvent method introduction of solvent causes weak cohesive inter and intra molecular interactions of polymer chain which in turn causes incorporation of dissolved drug molecules into loose polymer chains. This method used to increase the dissolution poorly water-soluble drug which improves the stability, bioavailability and solubility. The main advantage of this approach is that it avoids both drug and polymer thermal degradation i.e., organic solvents are evaporated at low temperature. The disadvantage in this method is phase separation (solvent removal) and expensive preparation.

- 4. Fusion Method:** Fusion method is a physical mixture of a drug the mixture is melted by preparing water soluble carrier as it is heated directly. After heating we will get a solid mass and this solid mass is crushed pulverised and sieved. During melting process, the drug or carrier may decompose due to high temperature. As heating the mixture in a sealed container or under vacuum or in the presence of inert gas like nitrogen we can prevent or overcome any problem. Fusion method is a technique used to increase the solubility as low soluble drugs. This method is to increase the dissolution rate and bioavailability of the substance. Therefore, improving their therapeutic effect and effectiveness<sup>[20]</sup>.

Selection of fusion method for solubility enhancement depends on various factors such as physiochemical properties of the drug, and route of administration, plus, dosage

form. Moreover, a systemic evaluation of different fusion methods and their impact on solubility is typically required to determine the most suitable approach for a specific drug or compound. Fusion method play an essential role in the formulation development of poorly soluble drug. There are certain fusion methods that enhance the solubility of drug and to increase the oral bio availability.

Generally, the fusion method technique can be used in solubility enhancement especially in pharmaceutical development. It contains poorly water-soluble drug into solid dispersion matrix though the process of fusion or melting.

- 5. Micronization:** Micronization is defined as the process of size reduction where the resulting particle size is 1-10 microns. many of the newly developed substances are poorly water soluble, which limits their bioavailability the dissolution rate of these drugs can be increased by using micronized drugs. This technique is beneficial in aspects that s does not require any external processing conditions except mild agitation using magnetic stirrer.

Micronization is used for pulmonary drug delivery systems which require a particle size of around 5 microns. Drug product obtained by this method is formulated into dry powder inhalers or aerosols because of improved aerodynamic behaviour .in this technique involves precipitation in presence of protective hydrophilic polymers followed by drying poorly soluble drug is to be dissolved in organic solvents hydrophilic polymer are dissolved in aqueous solvent which act as non-solvent to drug. Both solutions are mixed together to obtain precipitate then it is dried to drug product <sup>[10]</sup>. The figures are depicted in fig (1) and (2), of the instruments used in the micronization technique are:

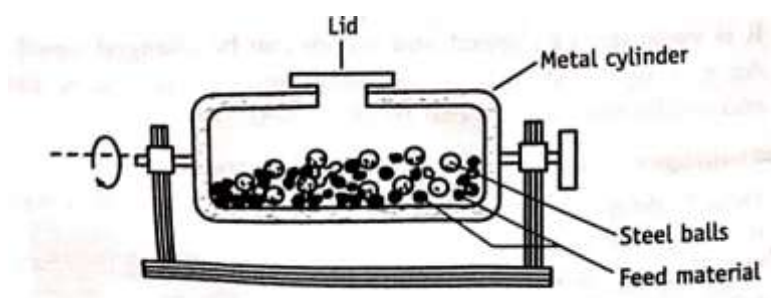

**Figure 1:** Diagrammatic representation of Ball mill

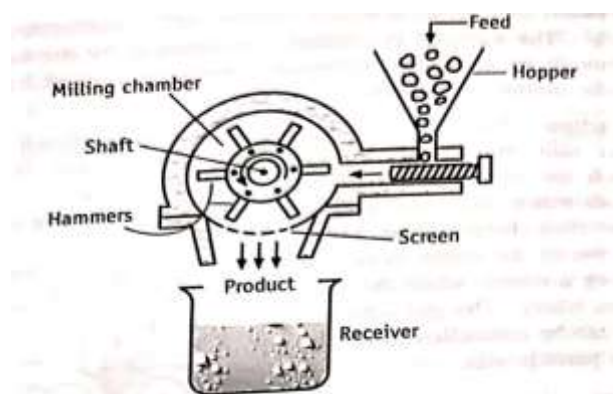

**Figure 2:** Diagrammatic representation of Hammer mill

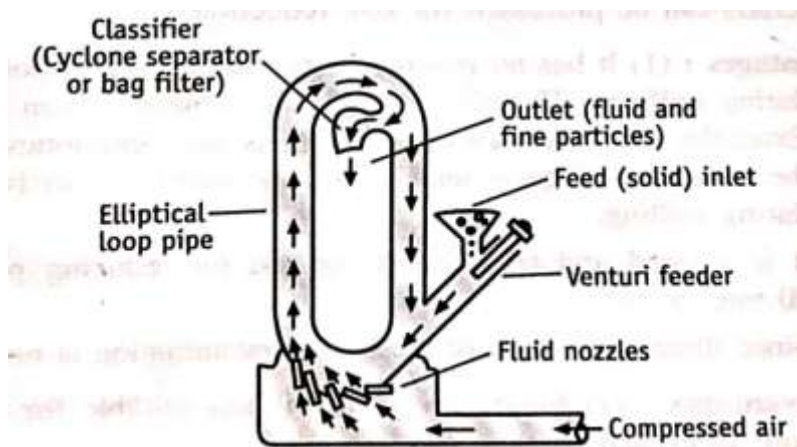

**Figure 3:** Diagrammatic representation of Jet mill

- 6. Nanosuspension:** Nano suspensions are submicron colloidal dispersions of Nano sized drug particles stabilized by surfactants. Nano suspensions consist of poorly water- soluble drug without any matrix material suspended in dispersion. These can be used to enhance the solubility of drugs that are poorly soluble in water as well as lipid media.as a result of increased solubility, the rate of flooding of the active compound increases and the maximum plasma level is reached faster. This approach is useful for molecules with poorly solubility, poor permeability or both, which poses a significant challenge for the formulators<sup>[21]</sup>.

The reduced particle size renders the possibility of intravenous administration of poorly soluble drugs without any blockade of the blood capillaries. The suspension can also be lyophilized into a solid matrix. This approach is useful for molecules with poor solubility, poor permeability, or both which poses a significant challenge for the formulators. The reduced particle size renders the possibility of intravenous administration of poorly soluble drugs without any blockade of the blood capillaries. The suspensions can also be lyophilized and into a solid matrix<sup>[23]</sup>.

#### IV. DRUG PROFILE

##### Dapsone

**Chemical Formula:**  $C_{12}H_{12}N_2O_2S$

**Iupac Name:** N,5-bis(4-chlorophenyl)-3-(propan-2-ylimino)-3,5- dihydrophenazin-2-amine

**Background:** Dapsone is a combination of clofazimine, and rifampicin used to treat leprosy and mostly sold under brand name of Lamprene.

**Color:** white to creamy white in colour

**Class:** Sulphone antibiotic

- 1. Mechanism of Action:** Since dapsone is used for both systemic and dermatological disease it possesses multiple mechanisms. Dapsone when treating leprosy act as an antibacterial agent on Mycobacterium leprae. It inhibits the folic acid pathway, particularly prevents bacteria from utilizing Para-aminobenzoic acid for the synthesis of folic acid. It is a competitive inhibitor of dihydropteroate synthase<sup>[3,4]</sup>.

In treatment of dermatological problems, the drug acts by affecting neutrophilic functions. Dapsone inhibits the myeloperoxidase-peroxidase halide-mediated cytotoxic system, which is component of neutrophil respiratory burst. Thereby it controls the degree neutrophilic-induced destruction lesions. Dapsone also decreases the adhesion of neutrophils to IgA<sup>[3]</sup>.

- 2. Anti Inflammatory Property:** As a dapsone acts as anti-inflammatory, it inhibits the myeloperoxidase-H<sub>2</sub>O<sub>2</sub>-halide mediated cytotoxic system in polymorphonucleocytes. It is part of respiratory burst that neutrophils use to kill bacteria, myeloperoxidase converts hydrogen peroxide(H<sub>2</sub>O<sub>2</sub>) into hypochlorous acid (HOCl). HOCl is the most potent oxidant generated by neutrophils and can cause tissue damage during inflammation. Drug arrests myeloperoxidase in an active intermediate form, irreversibly inhibiting the enzyme. This prevents accumulation of hypochlorous acid and reduces tissue damage during inflammation<sup>[4]</sup>.
- 3. Spectrum of Activity:** Dapsone has a broad spectrum of activity against various microorganisms, including bacteria, protozoa and some parasites. Dapsone exhibits antibacterial activity against mycobacterium leprae which is responsible for causing leprosy, Propionibacterium acnes it involved in development of acne vulgaris. Dapsone used for treatment of certain protozoal infections pneumocystis jirovecii cause severe pneumonia, toxoplasma gondii (dapsone is not used as first line drug instead pyrimethamine and sulfadiazine are preferred). Dapsone spectrum of activity can vary and need to be guided by specific indications and health care professional recommendation. Additionally, resistance to dapsone has been reported in some microorganisms such as mycobacterium leprae<sup>[4]</sup>.
- 4. Indication:** Dapsone has both FDA-approved and non- FDA approved indications. The FDA-approved indications are leprosy and dermatitis herpetiformis. The non- FDA approved indications include autoimmune bullous demonstrates such as sub corneal pustular dermatosis, pemphigus vulgaris. Vasculitis dermatoses such as leukocytoclastic vasculitis and urticarial vasculitis. Neutrophilic dermatoses such as sweet syndrome and Behcet- syndrome<sup>[4,5]</sup>.

**Solubility:**

**Absorbance maxima:** 290nm soluble in methanol, sparingly soluble in alcohols and acetone, insoluble in water

**Bioavailability:** Low or negligible

**Marketed formulation available:** tablets and gels

- 5. Therapeutic Efficacy:** Dapsone is a medication primarily used for the treatment of leprosy and certain types of skin condition such as dermatitis herpetiformis and acne. Dapsone is a key component of multi drug therapy for leprosy, which is recommended treatment by World Health Organisation (WHO). It is active against mycobacterium leprae, the bacterium responsible for leprosy. When used in combination with other drugs like rifampicin and clofazimine, dapsone helps to kill the bacteria, control progression of disease, and prevent transmission. Dapsone is considered the primary treatment for dermatitis herpetiformis, a chronic blistering skin condition associated with gluten sensitivity. Dapsone works by suppressing the immune response that triggers the skin

lesions in response to gluten ingestion. Dapsone found to be effective in the treatment of acne, particularly inflammatory acne lesions. It has both antibacterial and anti-inflammatory properties which help reduce the number of acnes causing bacteria and inflammation associated with acne breakouts. It is not effective for every person, and it also has potential side effects, including blood disorder, liver toxicity, and allergic reactions <sup>[5]</sup>.

## 6. Plan of Work

- Selection of material
- Selection of drug
- Formulation of dapsone nanoparticles by nanoprecipitation technique
- Formulation of dapsone nanosuspension
- Formulation of dapsone solid dispersion
- Formulation of dapsone micro particles by micronization technique
- Evaluation of the prepared formulation for solubility, drug content, invitro bioavailability studies,

## V. MATERIALS AND METHODOLOGY

- **List of Materials:** All the chemicals and equipment's used in the study were listed below:
- **List Of All Chemicals Used:** Dapsone, Ethyl cellulose, Tween -20, Methanol, Eudragit, Poloxamer, Poly vinyl pyrrolidone, Acetone, Urea

### Methodology

#### 1. Preparation of Dapsone Formulation by Nanoprecipitation Technique:

**Table 2:** Formulation table for F-1 Formulation

CHEMICALS	QUANTITY
Dapsone	500 mg
Ethyl cellulose	500 mg
Tween -20 (0.1%)	100 ml
Methanol	10ml
Distilled water	Q.S

**Table 3:** Formulation table for F-2 Formulation

CHEMICALS	QUANTITY
Dapsone	500 mg
Ethyl cellulose	1gm
Tween-20 (0.1%)	100ml
Methanol	10ml
Distilled water	Q.S



- **Experimental Procedure:** The weighed quantity of dapsone and ethyl cellulose was dissolved in 10 ml methanol (organic phase). 0.1% tween-20 was prepared, 1ml was pipetted out and diluted to 100ml of water (aqueous phase). It was kept for stirring about 20 minutes at 700rpm. The organic phase was added to aqueous phase dropwise with continuous stirring until it reaches end point. Appearance of whitish or precipitate indicates end point. This solution was kept in magnetic stirrer for about 2hr at a speed of 700rpm. After that filter the solution by manual filtration to obtain a product.

**Table 4:** Effect of surfactant in nanoprecipitation

Surfactant and its Concentration	Effect of Surfactant on the Property of Formulation
At Optimum Concentration of Surfactant	Desired Amount of Product is Achieved
At Low Concentration of Surfactant	Desired Amount of Product is not Achieved

- **Evaluation of the Formulation Prepared by Nanoprecipitation:**
  - **Percentage of product yield:** The obtained product was weighed after drying and the product yield was calculated by following formula:
    - ❖ Percentage of product yield = practical yield/theoretical yield x 100
  - **Solubility:** 10mg of drug product was weighed and dissolved in 10ml distilled water. The solution was kept in orbital shaker for 24hr. The solubility of dapsone was determined by U V Spectroscopy.
  - **Drug content:** 50mg of drug product was weighed and dissolved in 50ml of methanol. The solution was kept for magnetic stirring for 2hr at a speed of 700rpm by enclosing with aluminium foil to prevent evaporation of methanol. The Drug content of dapsone formulation was determined by UV spectrophotometry

## 2. Preparation of Dapsone Formulation by Solid Dispersion:

- **Solvent Evaporation Method:**

**Table 5:** Formulation table for F1 formulation

CHEMICALS	QUANTITY
Dapsone	100 mg
Poly vinyl pyrrolidine	1.5 gm
Acetone	5ml

**Table 6:** Formulation table for F2 formulation

CHEMICALS	QUANTITY
Dapsone	100 mg
Poly vinyl pyrrolidine	3 gm
Acetone	5 ml

- **Experimental Procedure:** Solid dispersion of Dapsone and PVP were made in ratio of 1:5 i.e., 100mg of dapsone was weighed in a China dish. A melt was formed by constant stirring and 1.5g of polymer (PVP) was added, melted for few minutes. Then solvent was added and stirred until the solvent is evaporated. After evaporation of solvent the material was removed and fine powder was obtained, then the dispersion was passed through sieve no:100 and uniform dispersion was obtained.
- **Fusion method**

**Table 7:** Formulation table for F-1 Formulation

CHEMICALS	QUANTITY
Dapsone	100 mg
Urea	1.5 gm

**Table 8:** Formulation table for F-2 Formulation

CHEMICALS	QUANTITY
Dapsone	100 mg
Urea	3 gm

- **Experimental Procedure:** The required quantity of urea was weighed and melted on hotplate above melting point of urea and then required quantity of dapsone was added to above content. The mixture was stirred continuously to prevent formation of clogs until they form congealed mass. It was cooled and then triturated in mortar and pestle, passed through sieve no 100 to obtain fine powder.

**Table 9:** Effect of polymer in solvent evaporation and fusion method:

Polymer and its Concentration	Effect of Polymer on the Property of Formulation
At Optimum Concentration of Polymer	Desired Amount of Product is Achieved
At Low Concentration of Polymer	Desired Amount of Product is Not Achieved

- **Evaluation of the Prepared Formulation by Solvent Evaporation and Fusion Method:**
  - **Percentage of product yield:** The obtained product was weighed after drying and the product yield was calculated by following formula:
    - ❖ Percentage of product yield = practical yield / theoretical yield X 100
  - **Solubility:** 10g of solid dispersion was accurately weighed and transferred to conical flask then to this flask 10ml of distilled water was added and kept in an orbital shaker at a constant temperature covered with aluminium foil 24 hours at 50rpm. The solubility of dapsone formulation was determined by flask shake

method. The solubility of dapson formulation was determined by UV spectrophotometric method

- **Drug Content:** 50mg of solid dispersion was weighed and dissolved in 50ml of methanol. The solution was kept for magnetic stirring covered with aluminium foil for 2 hours at a speed of 700rpm. The drug content of dapson formulation was determined by UV spectrophotometry
- **Determination of melting point:** solid dispersion prepared by both solvent and fusion method were taken into two different capillary tubes and inserted into melting point apparatus. The melting point for solid dispersion was measured using thermometer.

### 3. Preparation of Dapson Formulation by Micronization:

**Table 10:** Formulation table for F-1 Formulation

CHEMICALS	QUANTITY
Dapsone	200 mg
Eudragit	200 mg
Methanol	10 ml
Tween-20	50ml
Distilled water	50 ml

**Table 11:** Formulation table for F-2 Formulation

CHEMICALS	QUANTITY
Dapsone	200 mg
Eudragit	400 mg
Methanol	10 ml
Tween-20	50 ml
Distilled water	50 ml

- **Experimental Procedure:** the weighed quantities of dapson, eudragit was dissolved in 10 ml methanol (organic phase). It was kept for stirring for about 30 min at a speed of 700rpm. 0.1% tween-20 was prepared, 1ml of tween-20 was pipetted out and diluted to 50ml of distilled water (aqueous phase). Aqueous phase was kept in magnetic stirring for about 2hr at a speed of 700rpm. Aqueous phase was taken in round bottom flask and organic phase was added dropwise with continuous stirring until appearance of whitish precipitate which indicates end point. The above solution was kept for mechanical stirring for 3hr at a speed of 500rpm. Filter the solution by manual filtration to obtain product.
- **Evaluation of The Prepared Formulation by Micronization:**
  - **Percentage of product yield:** The obtained product was weighed after drying and the product yield was calculated by following formula:
    - ❖ Percentage of product yield = practical yield/ theoretical yield X 100

- **Solubility:** 10mg of drug product was weighed and dissolved in 10ml distilled water. The solution was kept in orbital shaker for 24hr at a speed of 50rpm. The solubility of dapsone formulation was determined by U V Spectrophotometry.
- **Drug content:** 50mg of drug product was weighed and dissolved in 50ml of methanol. The solution was kept for magnetic stirring for 2hr at a speed of 700rpm by enclosing with aluminium foil to prevent evaporation of methanol. The drug content of dapsone formulation was determined by U V Spectrophotometry.

#### 4. Preparation of Dapsone Formulation by Nanosuspension

**Table 12:** Formulation table for F-1 Formulation

CHEMICALS	QUANTITY
Dapsone	50 mg
Poloxamer	500 mg
Distilled water	100 ml

**Table 13:** Formulation table for F-2 Formulation

CHEMICALS	QUANTITY
Dapsone	50 mg
Poloxamer	1000 mg
Distilled water	100 ml

- **Experimental Procedure:** Required quantity of polaxamer, dapsone was weighed and dissolved it in distilled water. The solution was kept in probe sonicator for 2min at a speed 500rpm.

#### 5. Evaluation of The Prepared Formulation by Nanosuspension

- **Solubility:** 20 ml of aqueous solution was kept in orbital shaker for 24hr at speed of 50rpm. The solubility of dapsone formulation was determined by U V Spectrophotometry.
- **Drug content:** 10 ml of nanosuspension solution was added to 10ml of methanol. The solution was kept for magnetic stirring for 3hr at a speed of 700rpm by enclosing with aluminium foil to prevent evaporation of methanol. The drug content of dapsone was determined by flask shake method.
- **Dissolution studies:** The receptor chamber was filled with 50 ml of 7.4 PH buffer solution and donor chamber was filled with 1ml nanosuspension solution. Both the chambers were separated by dialysis membrane. Periodic removal of 1ml of solution from sampling port and addition of 1ml buffer to sampling port simultaneously to maintain sink condition. Sampling was done for every 20 minutes. The percentage of drug release was determined by U V Spectrophotometry.

## VI. RESULTS

The solubility of pure dapsone drug (10mg/ml) was found to be 37% by using orbital shaker. The solubility of dapsone was determined by UV Spectrophotometry. Standard plot for dapsone Dapsone drug shows linearity with Regression of 0.984 and slope of 0.287

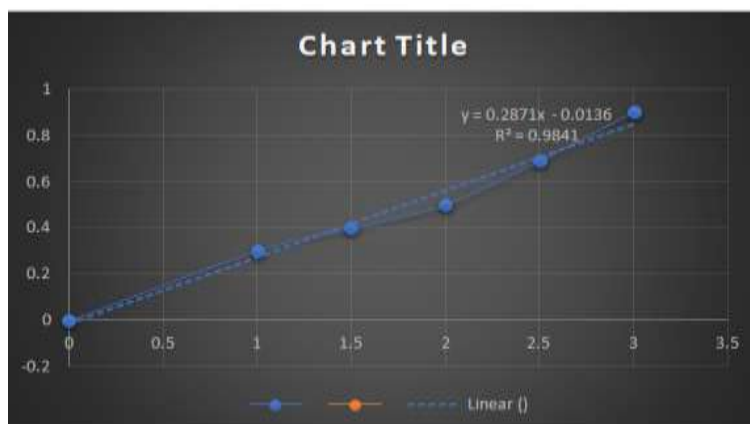

**Figure 4:** Standard plot of pure dapsone drug

### 1. Evaluation of the Formulation Prepared by Nanoprecipitation Technique:

- **Formulation-1:** The product yield of nanoparticles prepared by nanoprecipitation technique was observed to be 60%  
The drug content of prepared formulation by nanoprecipitation was found to be 92%  
The solubility of dapsone was enhanced to 74% by nanoprecipitation technique.
- **Formulation -2:** The product yield of nanoparticles prepared by nanoprecipitation technique was observed to be 66.6%  
The drug content of prepared formulation by nanoprecipitation was found to be 88.3%  
The solubility of dapsone was enhanced to 96% by nanoprecipitation technique

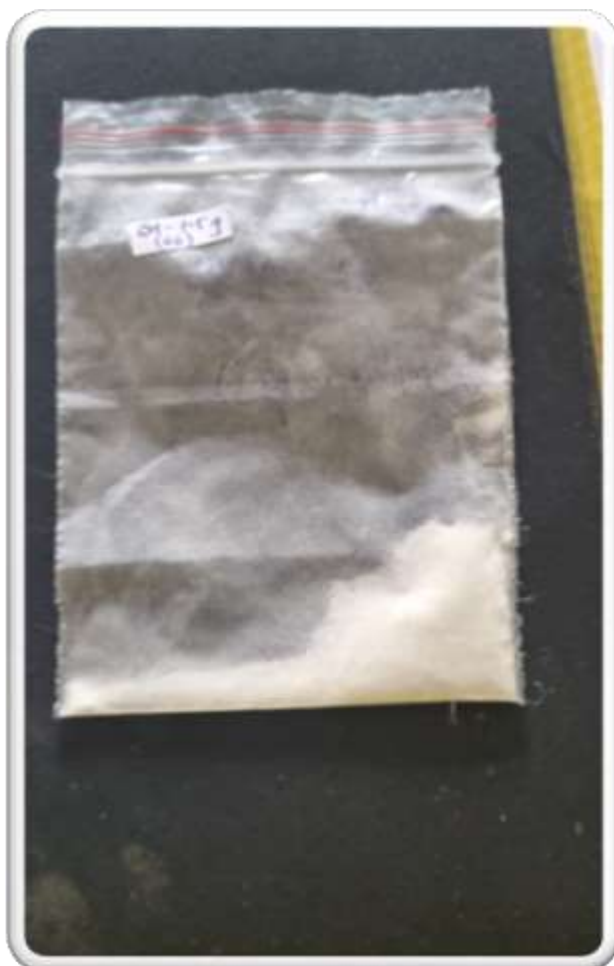

**Figure 5:** Formulation Prepared by Nanoprecipitation Technique

## 2. Evaluation of the solid dispersion prepared by solvent evaporation and fusion method

### ❖ Solvent Evaporation

- **Formulation-1:** The product yield of solid dispersions prepared by solvent evaporation method was observed to be 81.25%  
The drug content of prepared formulation by solvent evaporation was found to be 90%  
The solubility of dapsone was enhanced to 102.4% by solvent evaporation method  
The melting point of prepared formulation by solvent method was found to be 180°C
- **Formulation-2:** The product yield of solid dispersions prepared by solvent evaporation method was observed to be 72%  
The drug content of prepared formulation by solvent evaporation was found to be 87%  
The solubility of dapsone was enhanced to 83.27% by solvent evaporation method  
The melting point of prepared formulation by solvent method was found to be 179°C



**Figure 6:** Formulation Prepared by Solvent Evaporation Method

### ❖ Fusion Method:

- **Formulation-1:** The product yield of solid dispersions prepared by fusion method was observed to be 87.5%  
The drug content of prepared formulation by fusion method was found to be 95%  
The solubility of dapsona was enhanced to 104.9% by fusion method  
The melting point of prepared formulation by fusion method was found to be 178°C
- **Formulation-2:** The product yield of solid dispersions prepared by fusion method was observed to be 83.87%  
The drug content of prepared formulation by fusion was found to be 113%  
The solubility of dapsona was enhanced to 116.3% by fusion method  
The melting point of prepared formulation by fusion method was found to be 179°C

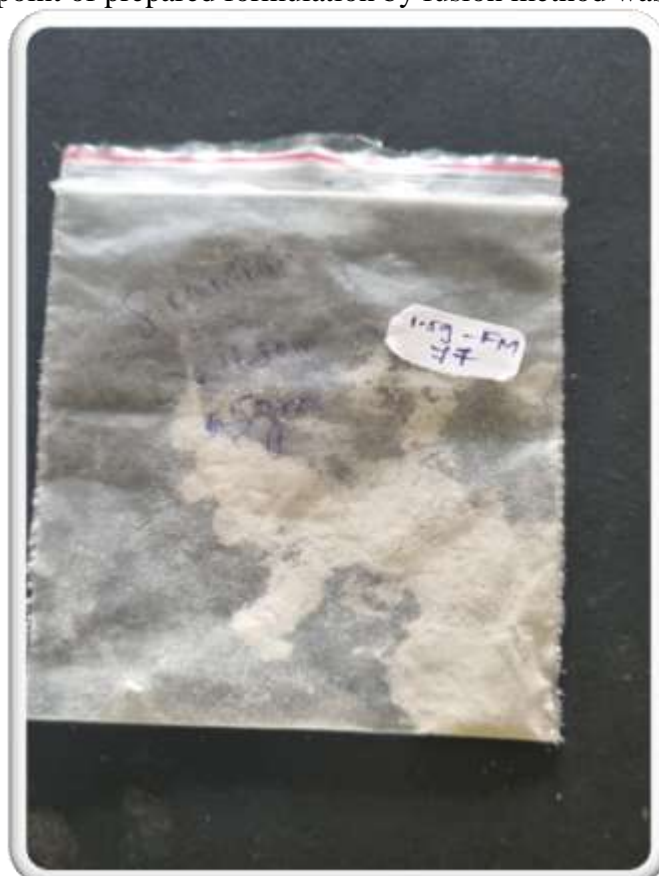

**Figure 7:** Formulation Prepared by Fusion Method

### 3. Evaluation of the Prepared Formulation by Micronization Technique:

- **Formulation-1:** The product yield of microparticles prepared by micronization was observed to be 79.5%  
The drug content of prepared formulation of dapsona by micronization technique was found to be 97%  
The solubility of dapsona was enhanced to 72% by micronization technique.

- **Formulation-2:** The product yield of microparticles prepared by micronization was observed to be 84.6%  
The drug content of prepared formulation of dapsones by micronization technique was found to be 112%  
The solubility of dapsones was enhanced to 88% by micronization technique.



**Figure 8:** Formulation Prepared by Micronization Technique

#### 4. Evaluation of the Prepared Formulation by Nanosuspension Technique:

- **Formulation-1:** The drug content of prepared formulation by nanosuspension technique was found to be 100%  
The solubility of prepared formulation was enhanced to 90.5% by nanosuspension technique
- **Formulation-2:** The drug content of prepared formulation by nanosuspension technique was found to be 100%  
The solubility of prepared formulation was enhanced to 92.5% by nanosuspension technique





**Figure 9:** Formulation Prepared by Nanosuspension Technique

## VII. DISCUSSION

Dapsone belongs to class-II drug exhibiting poor solubility, good permeability and good bioavailability. The bioavailability of dapsone through oral administration was 80%. The solubility of dapsone in water is 37%, this might affect therapeutic potential and results in low bioavailability. Dapsone is used in treatment of leprosy and other dermatitis problems. To enhance dapsone solubility several techniques have been adopted such as nanoprecipitation technique, solvent evaporation & fusion method, micronisation, nanosuspension methods.

Dapsone nanoparticles were prepared by nanoprecipitation technique. Two formulations (F1, F2) were developed by altering drug to polymer ratio. Prepared formulation was evaluated for drug content, solubility, percentage of product yield. The F1 formulation of prepared nanoparticles exhibiting solubility of 74%, drug content of 92%, product yield of 60%. The F2 formulation of prepared nanoparticles exhibiting solubility of 96%, drug content of 88.3%, product yield of 66.6%. Out of this two formulations F2 increased solubility than F1 due to altered drug polymer ratio.

Solid dispersion of dapsone powder was prepared by solvent evaporation and fusion method. In solvent evaporation method and fusion method two formulations were prepared

by for each method. The evaluation test were done for both prepared solid dispersions and it shows solubility of fusion method is more when compared with solvent evaporation method. The solubility of F1, F2 formulations of solvent evaporation method was observed to be 102.4%, 87%. The solubility of F1, F2 formulations of fusion method was observed to be 104.9%, 116.3%.

Dapsone microparticles were prepared by micronisation technique using solvent evaporation method. Two formulations (F1, F2) were developed by altering drug to polymer ratio. Prepared formulation was evaluated for drug content, solubility, product yield. The F1 formulation of prepared microparticles exhibiting solubility of 72%, drug content of 97%, product yield of 79.5%. The F2 formulation of prepared microparticles exhibiting solubility of 88%, drug content of 112%, product yield of 84.6%. Out of this two formulations F2 increased solubility than F1 due to altered drug polymer ratio.

Dapsone nanoparticles were prepared by nanosuspension technique by using probe sonicator. The two formulations were formulated and evaluated for solubility, drug content. The enhanced solubility in nanosuspension technique was found to be in F2 prepared formulation which is 92.5%.

## VIII. CONCLUSION

In this study, attempts have been made to improve solubility of dapsone by adapting several techniques such as nanoprecipitation, solvent evaporation & fusion method, micronisation, nanosuspension methods. Initially the solubility of dapsone in aqueous medium was observed to 37%. By adopting the solubility enhancement techniques the solubility of dapsone was enhanced to 116.3%. All techniques were proved to be good solubility enhancing techniques for dapsone. These techniques were promising techniques in improving solubility of dapsone. The aims and objectives were fulfilled and achieved.

## REFERENCES

- [1] Leon Lachman, Herbert A Lieberman's Roop K Khar, S P Vyas, Farhan J Ahmad, Gaurav K Jain. Industrial pharmacy. Solubility studies, 4<sup>th</sup> Edition, CBS Publishers and distributors pg:271-278.
- [2] CVS Subrahmanyam. Biopharmaceutics and pharmacokinetics concepts and application. physicochemical factors influencing drug absorption, 2<sup>nd</sup> Edition, Delhi Vallabh Prakashan, pg:101-112.
- [3] Williams. Foye's principles of medicinal chemistry, 5<sup>th</sup> edition, classification of drugs, Lippincott's Williams and wilkins publication pg no: 456-460.
- [4] Hughes W, Smith.B. Antimicrobial agents for chemotherapy 1984. efficacy of diamino diphenyl sulphone and other drugs in murine pneumocystis carinii pneumonitis, pg no: 436-440.
- [5] Ahmad RA, Rogers HJ. Clinical pharmacology. pharmacokinetics and protein binding interaction of dapsone pg no: 519-524.
- [6] Raneev thakur, Abhishek Sharma, Vimal Arora. world scientific journal (2023), Nanoparticles methods for hydrophobic drugs- A Novel approach: graphical abstract pgno: 2-7.
- [7] Lepeltier, couvreur. advanced drug delivery 2014, Nanoprecipitation and ouzo effect: Application to drug delivery devices 2014; pgno:86-97.
- [8] Jasdeep hitanga, Neha Sharma, Hitesh Chopra, Dr. Sandeep Kumar. world journal of -pharmaceutical research. A Review: Nanoprecipitation technique employed for development of nanosuspension 2015; Volume-4, pg no:2127-2134.
- [9] Govender T, Stolnik S, Garnett M C, Illum L, Davises. Journal of control release. PLGA nanoparticles prepared by nanoprecipitation drug loading and release studies of a water-soluble drug 1997; Pg no:171-185.

- [10] K. R Vandana, Y. Prasanna Raju, V.Harini Chowdary, M.Sushma, N. Vijaya Kumar. Saudi Pharmaceutical journal . Insitu-micronization technique: An emerging novel concept in advanced drug delivery 2014; Pg no:283-289.
- [11] Saeeda, enteshari, Jalehvarshosaz. Advanced biomedical research. solubility enhancement of domeperidone by solvent change insitu micronization technique2018; Pg no:1-7.
- [12] Ujwala Desai, Praveen D. Choudhari, pravin S.Uttekar, Deepak Pawar. American journal pharmaceutical research. formulation and evaluation of microparticle formed by InSitu micronization technique: Optimization of process parameter2013; Pgno:878-898.
- [13] D.K Sharma. Asian journal of pharmaceutics. solubility enhancement strategies for poorly water-soluble drugs in solid dispersion2016; Pg no:273.
- [14] Laximikanth.B, Madhuri T Deshmukh. journal of drug delivery and therapeutics. Review on solubility enhancement by solid dispersion2021; Pg no:148-154.
- [15] Sharma R, Sharma A, Varma P, International journal of pharmacy and life sciences (2013), A Review of solid dispersion, Pg no:2845-2854.
- [16] D.M Brahmanekar, Sunil B Jaiswal. Biopharmaceutics and pharmacokinetics, 3<sup>rd</sup> edition, solubility enhancement techniques-Solid dispersion, Vallabh prakshan publishers; Pg no:298-300.
- [17] Gurjeet Singh, lakhvir kaur. Solid Dispersion: An eminent technology to improve solubility, solvent evaporation method; Pg no:180-183.
- [18] G. Y Sharwan Kumar, G.Naveen. World journal of pharmaceutical research. Review on solid dispersion methods 2019; Pg no:340-351.
- [19] Ruba Malkawi. Current trends on solid dispersion past present and future 2022
- [20] Javed Ali, Mohammad Fazil. Development and evaluation of solid dispersion of spironolactone using fusion method, Pg no:63-68.
- [21] Harshil M Patel, Bhumi B Patel, International journal of advances in pharmaceutics. Nanosuspension in Novel approach to enhance solubility of poorly water-soluble drugs 2016; vol-5 pg no:21-29.
- [22] B.Shrannavar, S. Sawant. International journal of pharmaceutical science (2020), formulation and evaluation of nanosuspension of rovastatin for solubility enhancement, Pg no:5949-5958.
- [23] Shivaraj popat Jadhav, santhosh kumar singh. Advances in pharmacology in pharmacy. review on nanosuspension as novel method for solubility and bioavailability enhancement of poorly soluble drugs 2022; Pg no:117-128.
- [24] Sarika V Khandbahale. Asian Journal of pharmaceutical research. A review- Nanosuspension technology in drug delivery system 2019; vol-9: pg no:2231-5691.
- [25] S.Naveen, Y.Kavya. challenges and advancement in pharmaceutical research. A comprehensive review of pharmaceutical nanosuspension as a nanotechnology tool for solubility enhancement 2022; 9: Pg no:1-10.
- [26] Rasenack, N.Muller. Pharmaceutical research. Dissolution rate enhancement by in situ Micronization of poorly water-soluble drugs 2002 ;Pg no 1894-1900.
- [27] Amit Kumar Nayak, Kunal Pal, Indranil Banerjee, Samarendra Maji and Upendranath Nanda. Advances and challenges in pharmaceutical technology. Micronization of poorly soluble drugs 2021; Pg no:190-197.
- [28] Laxmi Raj, Shravan Kumar. Evaluation of solid dispersion of Nebivolol using solvent evaporation method. International journal of pharmaceutical science and research 2018; Pg no:322-328.