

# PREPAID ENERGY METER

## Abstract

A prepaid digital energy meter through GSM (Global System for Mobile Communications) capability is a type of electricity meter that permit clients to pay for their electricity in advance and remotely, using their mobile phones or computers. The GSM capability enables the meter to communicate with the power utility company, allowing customers to receive real-time updates on their energy usage, account balances, and recharge options. The meter is equipped with a SIM card that enables it to communicate with the power utility company's servers through a mobile network. Customers can purchase electricity credits by sending an SMS message or by using an online payment system. Once the payment is processed, the meter is automatically credited with the purchased amount of electricity.

The prepaid digital energy meter with GSM capability provides several benefits, including

- 1. Improved Accuracy:** The meter measures the exact amount of energy consumed by the customer, providing accurate billing information.
- 2. Better Control:** Customers can monitor their energy usage in real-time and adjust their consumption to avoid overages or excessive usage.
- 3. Convenience:** The meter allows customers to purchase and top up their electricity credits remotely, using their mobile phones or computers.
- 4. Cost-Saving:** Prepaid meters help customers to manage their energy consumption, which can result in reduced energy bills.

Overall, prepaid digital energy meters with GSM capability are becoming

## Authors

### T Rengaraj

Department of EEE  
PSR Engineering College  
Sevalpatti, Sivakasi, Virudhunagar, India  
rajpriya160619@gmail.com

### S Ramasamy

Department of ECE  
PSR Engineering College  
Sevalpatti, Sivakasi, Virudhunagar, India  
sramasamyece90@gmail.com

### S Sambooranalaxmi

Department of ECE  
PSR Engineering College  
Sevalpatti, Sivakasi, Virudhunagar, India.  
samboognee@gmail.com

### Rajat Kumar Dwibedi

Department of ECE  
Aarupadai Veedu Institute of Technology  
Vinayaka Mission's Research Fountation  
(Deemed to be University)  
Chennai, Tamil Nadu, India  
rajatsrr@gmail.com

increasingly popular as they offer a more convenient and efficient way of managing energy usage and payments.

**Keywords:** Digital energy meter, GSM (Global System for Mobile Communications), SIM card.

## I. INTRODUCTION

1. **General:** In human life electricity is more important one. I agree that electricity is a vital requirement for sustaining life, and it is important to use it judiciously to ensure its proper utilization. It is unfortunate that many areas in our country do not have access to electricity, while some areas have surplus supply. Proper distribution of electricity is essential to ensure that everyone has access to this vital resource. The subject of power theft is a major trouble that requirements to be addressed. It is important to accurately estimate the required amount of power and take measures to prevent power theft to ensure that the power supply is not disrupted. In addition, power companies need to improve their services and address consumer complaints to ensure that customers are satisfied. The use of smart energy meters can help to address some of these issues. Smart meters provide accurate information on energy consumption, reducing the chance of errors in the billing system. They also allow for remote monitoring of energy consumption, which can reduce the need for manual meter reading, saving time and reducing human efforts. This technology can also help to identify areas with high energy consumption and provide insights on how to improve energy efficiency. Overall, the use of smart energy meters is a step in the right direction towards ensuring the proper distribution and efficient utilization of electricity
2. **GSM- Based Meter:** GSM-based prepaid energy meters use a GSM module to facilitate message among the meter and the utility company's server. Consumers can use a mobile phone to recharge their prepaid account through SMS. Here are some key features and benefits of GSM-based prepaid meters.
  - **Real-Time Monitoring:** GSM-based prepaid meters allow for real- time monitoring of electricity consumption. This means that consumers can track their energy usage and adjust their behavior accordingly to conserve energy.
  - **Instant Recharge:** Consumers can recharge their prepaid account instantly through SMS or USSD codes. This eliminates the need to physically visit a recharge station or the utility company's office to recharge the account.
  - **Automatic Disconnection:** Once the prepaid account balance is exhausted, the GSM-based prepaid meter automatically disconnects the power supply. This helps to prevent electricity theft and encourages consumers to use electricity judiciously.
  - **Cost Savings:** The use of GSM technology in prepaid energy metering reduces operational costs for the utility company. This is because manual meter reading and billing processes are eliminated, and the entire process becomes automated.
  - **Improved Revenue Collection:** With GSM-based prepaid meters, the utility company can collect revenue in advance, ensuring a steady cash flow. This helps to improve the financial health of the utility company and enables it to invest in infrastructure development and maintenance.

## II. LITERATURE REVIEW

### Chapter Introduction

- 1. Energy Usage in Advance:** Prepaid energy meters have gained popularity as a solution for managing electricity consumption and billing). (1) A review on prepaid energy meter based on GSM technology, (2) Monitor their real- time energy consumption, and avoid unexpected bills. Prepaid energy meter using GSM technology. This chapter aims to Design and development of a prepaid energy meter using GSM technology (3) their benefits and challenges, and the need for Design and implementation of a prepaid energy meter (4) (5) and Prepaid Energy Meter Using Arduino to ensure their accuracy and fairness. We will examine the impact of prepaid meters on energy consumption and (6) Prepaid Energy Meter Using Arduino, as well as the accuracy and fairness of billing practices. Additionally, we will explore the affordability and accessibility of prepaid meters, particularly for low-income households. Moreover, we will review the existing literature on prepaid energy meters to provide insights into the potential benefits and challenges associated with their use. Prospects and challenges (7)(8) of relevant studies on prepaid energy meters, including their impact on energy consumption, accuracy and fairness of billing practices, and A review of prepaid energy meter (9). The insights provided in this chapter will be useful for policymakers, energy suppliers, and consumers who are interested in using prepaid energy meters for managing electricity consumption and billing.
- 2. Managing Electricity Consumption:** Prepaid energy meters have emerged as an innovative solution Practical Approach for Sustainable Energy Supply (10) and billing. These meters enable consumers to pay for their energy usage in advance, monitor their real-time energy consumption, and avoid unexpected bills. A Zig Bee-Bound Home Automation System WEE Tra C422-430 (15). We will examine the impact of prepaid meters on energy consumption. This paper provides an overview of the working principle and implementation of a prepaid energy meter with GSM technology (11), as well as the accuracy and fairness of billing practices. Additionally; we will explore the affordability and accessibility of prepaid meters, especially for low-income households. This paper presents a detailed description of the design and implementation of a prepaid energy meter with GSM network (12).Furthermore, we will review the existing literature on prepaid energy meters to provide insights into the potential benefits and challenges associated with their use. The literature review will examine the findings of relevant studies on prepaid energy meters, including their impact on energy consumption, accuracy and fairness of billing practices, and affordability and accessibility. This chapter aims to provide policy makers, this paper presents a detailed description of the design and development of a prepaid energy meter using GSM technology (13), (14). of prepaid energy meters, their potential benefits and challenges, and the need for proper maintenance and regulation. The insights provided in this chapter can assists take holders in making informed decisions about the use of prepaid energy meters for managing electricity consumption and billing.

## III. PROPOSED SYSTEM

A prepaid energy meter with GSM (Global System for Mobile Communications) operates on the principle of allowing users top repay for their electricity usage before they consume it. The meter uses a GSM module to communicate with a remote server, which manages the prepayment process and sends instructions to the meter to allow or deny access to

electricity. Here is a brief overview of the working principle of a prepaid energy meter with GSM: The user purchases a prepaid electricity token from a vending point, which could be a physical outlet or an online portal. The token contains a unique code that represents a specific amount of electricity units (kWh). The user enters the code into the prepaid meter's keypad to load the units onto the meter. The prepaid meter communicates with a remote server through a GSM module that is embedded within the meter. The server validates the token code and updates the meter's internal memory with the amount of prepaid units purchased. Here Figure 1 & Figure 2 is represented block diagram and working diagram of proposed method.

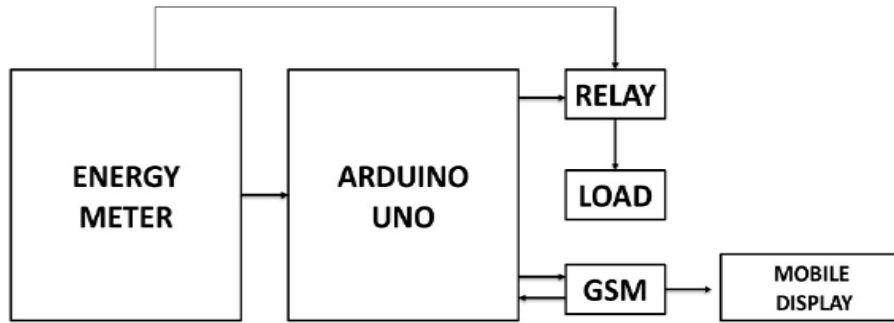

**Figure 1: Block Diagram**

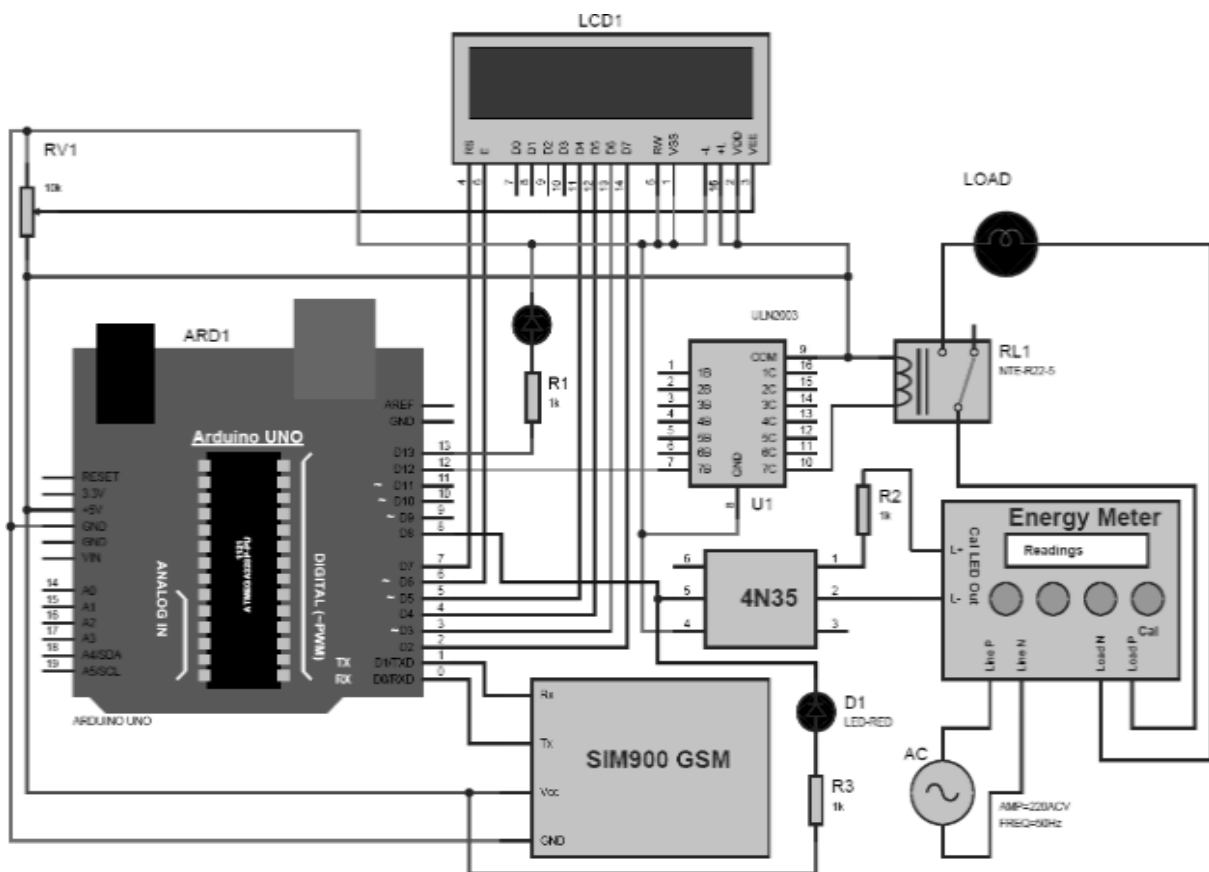

**Figure 2: Working Operation**

### Recharge Measured For LCD Display



**Figure 3: Measure Balance**

**Table 1: Calculation Values**

Recharge	Price	Unit	Pulse
ATrech1	100	10	1000
ATrech2	200	20	2000
ATrech3	300	30	3000

From Figure 3, the methods display the measured value. The Calculated values are displayed in Table 1.

### IV. CONCLUSION

With this type of meter, users can purchase credits for their energy usage, and the meter deducts the credit as energy is consumed. The hardware implementation of prepaid energy meters was found to be a more challenging and expensive process compared to simulation. However, it provided more accurate and reliable results. The use of physical components and sensors enabled the system to monitor and control energy consumption effectively. Overall, prepaid energy meters with GSM technology offer a convenient, secure, and efficient way for users to manage their energy consumption and cost.

### REFERENCES

- [1] M. Ahmad, et al. (2016). A review on prepaid energy meter based on GSM technology. *International Journal of Advanced Research in Electrical, Electronics and Instrumentation Engineering*, 5(3), 2295- 2302.
- [2] S. S. Suryawanshi, et al. (2016). Prepaid energy meter using GSM technology. *International Journal of Advanced Research in Electrical, Electronics and Instrumentation Engineering*, 5(2), 1661-1665.
- [3] R. V. Ghodke, et al. (2017). Design and development of a prepaid energy meter using GSM technology. *International Journal of Science, Technology and Management*, 6(2), 42-47.
- [4] D. I. Ugwueze, et al. (2018). Design and implementation of a prepaid energy meter using GSM technology. *International Journal of Engineering and Technology (UAE)*, 7(4.41), 181-187.
- [5] P. N. Nwankwo, et al. (2019). Design and implementation of prepaid energy meter using GSM technology.

- International Journal of Scientific and Research Publications, 9(8), 421-425.
- [6] "Prepaid Energy Meter Using Arduino" by S. S. Naik and S. D. Dhamal, International Journal of Emerging Technology and Advanced Engineering, vol. 6, no. 6, pp. 122-125, June 2016.
  - [7] "Prepaid energy meter using GSM technology" by N. Anand and K. S. Rajan, International Journal of Advanced Research in Electrical, Electronics and Instrumentation Engineering, vol. 3, no. pp. 11983- 11988, July 2014.
  - [8] "Design and Implementation of Prepaid Energy Meter using Smart Card" by A. T. Shittu and A. B. Makanjuola, International Journal of Electrical and Computer Engineering, vol. 2, no. 4, pp. 443-450, August 2012.
  - [9] "A review of prepaid energy metering in Nigeria: Prospects and challenges" by O. A. Ajewole and S. A. Oladokun, Renewable and Sustainable Energy Reviews, vol. 33, pp. 229-238, March 2014.
  - [10] "Prepaid Energy Metering System: A Practical Approach for Sustainable Energy Supply in Nigeria" by A. O. Fagbenle, A. O. Akinbode, and E. M. Okoroigwe, Journal of Energy Technologies and Policy, vol. 3, no. 1, pp. 11-21, January 2013.
  - [11] "Prepaid Energy Meter with GSM Technology" by S. S. Sangle and S. D. Dakhole, International Journal of Engineering Research and Applications, Vol. 4, Issue 8, August 2014.
  - [12] "Design and Implementation of Prepaid Energy Meter Using GSM Network" by M. S. Bada and O. O. Fakolujo, Journal of Computer Sciences and Applications, Vol. 3, No. 3, June 2015.
  - [13] "Prepaid Energy Meter with GSM and Arduino Based Microcontroller" by J. A. Singh and A. K. Verma, International Journal of Advanced Research in Computer Science and Electronics Engineering, Vol. 2, Issue 6, June 2013.
  - [14] "Design and Development of a Prepaid Energy Meter Using GSM Technology" by S. S. Adeyemo and S. O. Oyedele, Journal of Emerging Trends in Engineering and Applied Sciences, Vol. 5, No.2, February 2014.
  - [15] Karvinder Gil et al "A ZigBee-Bound Home Automation System WEE Tra C422-430 MAY 2000