

EVOLUTION AND APPLICATION OF SMART SOIL MOISTURE SENSING TECHNOLOGIES IN PRECISION AGRICULTURE

Abstract

In Pedology and agricultural management, soil moisture is crucial for maintaining the physicochemical, biological, agronomical, ecological, hydrographical, and geomorphic soil features. The framework for managing irrigation and making efficient use of available water resources is provided by the soil moisture detection system. It contributes significantly to Precision Agriculture (PA) by constant monitoring of humidity and moisture content data in real-time. The high cost, the necessity of site-specific measurement, poor performance, and small sampling capacity of soil humidity sensors limit their applications. The objective is to investigate the effectiveness of all soil moisture monitoring systems in addition to the developments in novel detection methods and to assess their applicability in agricultural soil management. Based on their performance and design, a study of the benefits and drawbacks of soil moisture detectors is conducted. The development of sensor systems has led to an improvement in detection approaches by utilizing a set of technologies, including Wireless Sensor Networks (WSN), Internet of Things (IoT) and Remote Sensing (RS). The diverse RS, IoT, and WSN techniques utilized in Precision Agriculture are covered in this overview, along with their effects on the progress of "smart agriculture." This paper conducts a rigorous review of the WSN, RS, and agricultural IoT research status. To achieve smart and intelligent agricultural production, the study also focuses on the optimization of environmental parameters, such as soil property monitoring and

Authors

Dr. Chaitra B. S

Assistant Professor
Department of Biotechnology Saphthagiri
College of Engineering
Bangalore, Karnataka, India.
chaitrabs@saphthagiri.edu.in

Dr. Gouri Mirji

Assistant Professor,
Department of Biotechnology Saphthagiri
College of Engineering
Bangalore, Karnataka, India.
gourimirji_bt@saphthagiri.edu.in

Dr. Sowmya C

Assistant Professor,
Department of Biotechnology Saphthagiri
College of Engineering
Bangalore, Karnataka, India.
sowmya@saphthagiri.edu.in

irrigation management. Moreover, the issues and difficulties associated with detecting soil moisture are examined, and a projection for the future growth of agricultural IoT, RS, and WSNs is provided. Finally, this review discusses how novel technologies are potentially applied to detect soil moisture.

Keywords: Soil moisture, Precision Agriculture (PA), Thermo- gravimetric technique (oven- drying), Calcium carbide technique, Sensors, Wireless Sensor Networks (WSNs), Agricultural Internet of Things (IoT), Remote sensing (RS), Monitoring, Irrigation.

I. INTRODUCTION

Soil is the top-most geological component on the earth's crust, which provides water and nutrients for plant growth. It has a huge significance in the field of agricultural management. There are various soil parameters affecting plant growth and development, such as soil- moisture, soil- temperature, and soil organic carbon sequestration (SOC sequestration).^[1]

Soil- Moisture is the quantity of soil- water, that constitutes the dampness and humidity in the soil. It is important in climate modeling and weather forecasting. It is a significant aspect in the determination of net yield, and in considering the characteristic behaviours in the conduct of water content. Finding precise soil- water contents is limited due to the several variants affecting the quality such as salinity, thermal aspects of soil, the assembly of soil particles, including saturation of soil particles. Soil- Moisture Sensors (SMS) are chiefly used as the support for cultivators in the scheduling of irrigation and freshwater management.

Efficient water- management is becoming increasingly crucial for farmers.^[2] Water is a vital tool in the process of cultivation, hence, appropriate supervision of irrigation acts as a critical factor in atmospheric changes. The capability of agri-business to retain profitability amidst calamitous events, and to obtain information on irrigation is remarkably important with the application of soil- moisture sensors. The utilization of sensors is intensifying in all arrays of agricultural activities. The competence and outcome of mounted sensors in precision agriculture and ecological applications are noteworthy.^[2]

II. SOIL MOISTURE SENSORS (SMS)

The Soil- Moisture Sensor is an instrument coupled with an irrigation system regulator that estimates soil moistness in the active zone of the roots. The estimation of soil moistness that is given by electric- resistivity, was preferred by cultivators. It was because of the ease to attain accurate results with negligible effort.^[2] Consequently, resistivity-based soil- moisture sensors are also used in a greenhouse setup. Sensors are constantly subjected to adjustments to increase their performance in assessments.^[1] Soil- moisture detectors provide a mode to expand production efficacy. Nevertheless, they are still challenging to adopt such approaches due to the cost inefficiency and the absence of soil-specific calibration relations.^[3]

III. PRECISION AGRICULTURE (PA)

The agricultural farm management method, that uses data and technology to ensure all necessities of crops and soil, to maintain their optimum strength and productivity, is called Precision Agriculture (PA). The key objective of the method is the utilization and integration of various technologies to produce high-yield, profitable and sustainable crops while preserving the used resources.^[3] The practice of PA leads to:

- 1 Maximum crop production
- 2 Preservation of resources
- 3 Profitability

- 4 Sustainability
- 5 Environmental protection.



Figure 1: New Paradigm for Precise Agriculture ^[3]

IV. EVOLUTION OF SOIL MOISTURE SENSING TECHNIQUES

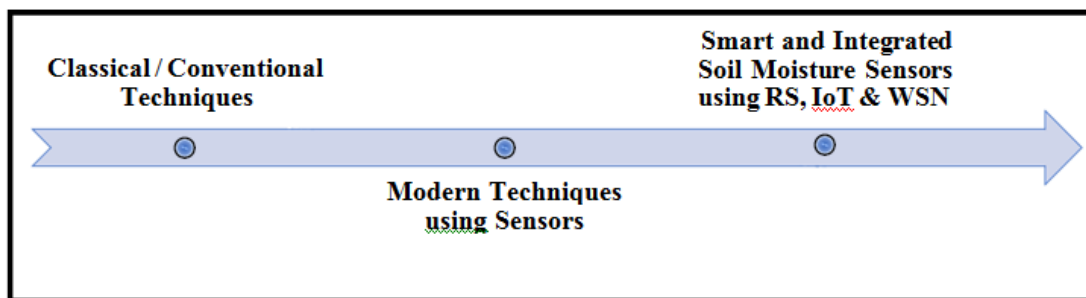

Figure 2: Evolution of Soil Moisture Sensing Techniques

V. CLASSICAL / CONVENTIONAL SOIL- MOISTURE SENSING TECHNIQUES

Conventional soil moisture detection involves the removal of moisture- content from the soil analyte by either the process of evaporation or a chemical reaction. This class of techniques includes thermo- gravimetric and calcium carbide reagent techniques.^[5] There are various other spectroscopic methods to estimate the soil moistness quantity.

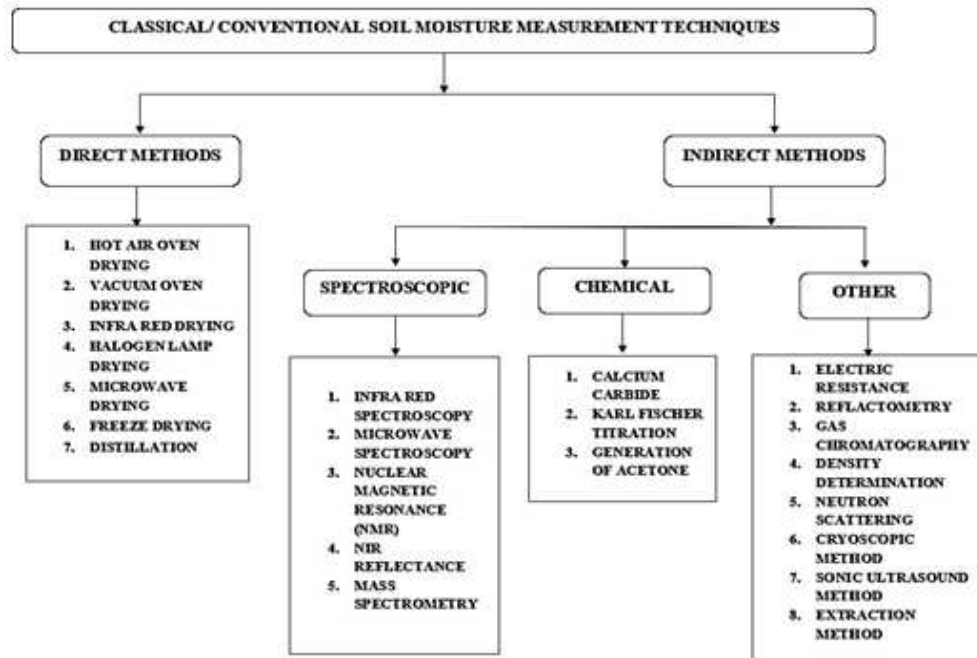

Figure 3: Classical/ Conventional Soil- Moisture Sensing Techniques

1. Thermo- Gravimetric Technique (Oven-Drying): The thermo- gravimetric technique is also termed as an oven- drying. It is generally employed for the measurement of soil humidity. It is the standard reference in the determination of soil- water content. In this method, moist soil is taken as a sample and is exposed to oven- drying for 1 day, at 105°C, and the dry mass of the soil sample is subsequently recorded.

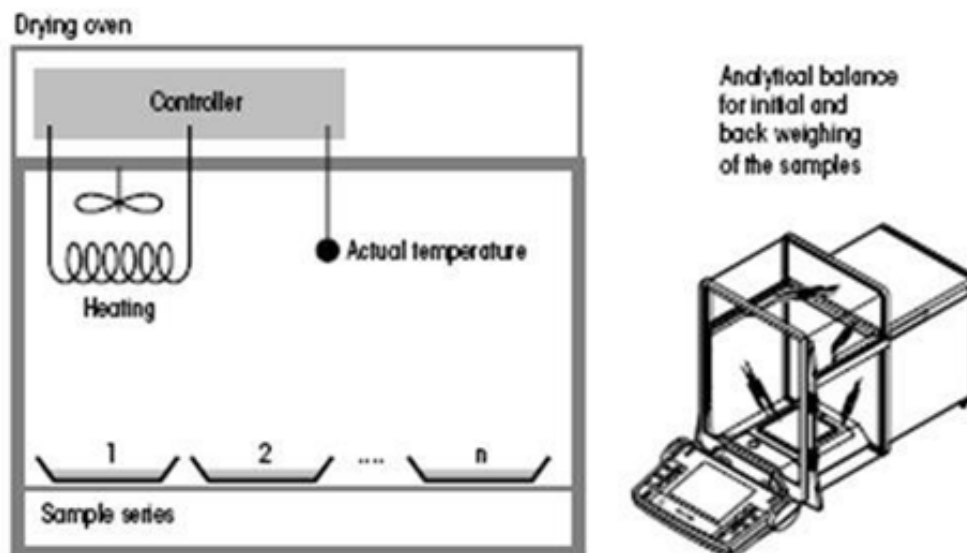

Figure 1: Thermo-Gravimetric Technique of Soil Measurement ^[5]

$$\text{water content} = \frac{w_2 - w_3}{w_3 - w_1} \times 100$$

Where,

- w_1 - Weight of empty container
- w_2 - Weight of sample (wet soil + container)
- w_3 - Weight of sample after 24 hours in the oven (dry soil + container)

2. Calcium Carbide Technique:

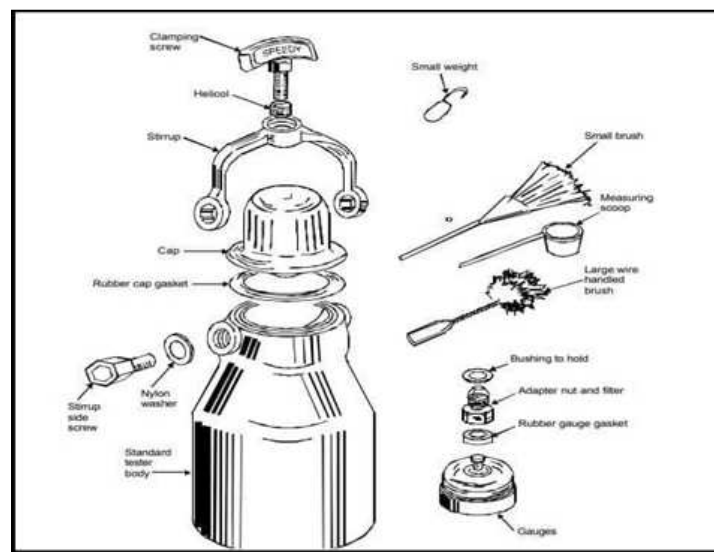

Figure 2: Calcium Carbide Tester ^[5]

The calcium carbide reagent method is a rapid-testing method that may be used in the field or in a lab to determine how much moisture is present in the soil. The developed gas pressure determines how much soil moisture is present in the specific wet or moist soil. This results from the reaction between the chemical reagent of Calcium Carbide with the soil- water. Acetylene is released as a gas, that is directly proportional to the quantity of readily obtainable soil- moisture, and it can be measured inside a sealed chamber. A pressure gauge device is used to measure the apparent moisture- content. It is typically calibrated using the gravimetric soil moisture content. This approach does not yield characteristic findings because a few volumes of the water may be stuck within the soil clumps, which may not interact with the Calcium Carbide reagent in very plastic clay soils or other unbreakable soil particles. Additionally, a 2 g sample takes roughly 2.2 g of calcium carbide and highly qualified staff are needed to conduct the tests.

$$\theta = w \cdot (\gamma_d / \gamma_w)$$

- θ → Volumetric soil moisture content
 w → Gravimetric soil moisture content
 γ_d → Dry-unit weight of the soil mass
 γ_w → Unit weight of water

VI. ADVANCED SOIL- MOISTURE SENSING TECHNIQUES

Current soil- moisture sensing methods investigate the soil's electric properties like dielectric property, impedance, capacitance, and soil resistance. The application of high electrode potential, the exposure of infrared rays and microwaves and various radioactive methods like neutron scattering technique, gamma rays' attenuation, and other optical methods are also adopted. Unlike the exposure to infrared rays, the amount of soil- water can be determined in both laboratories and in- situ applications using these methods. ^[6]

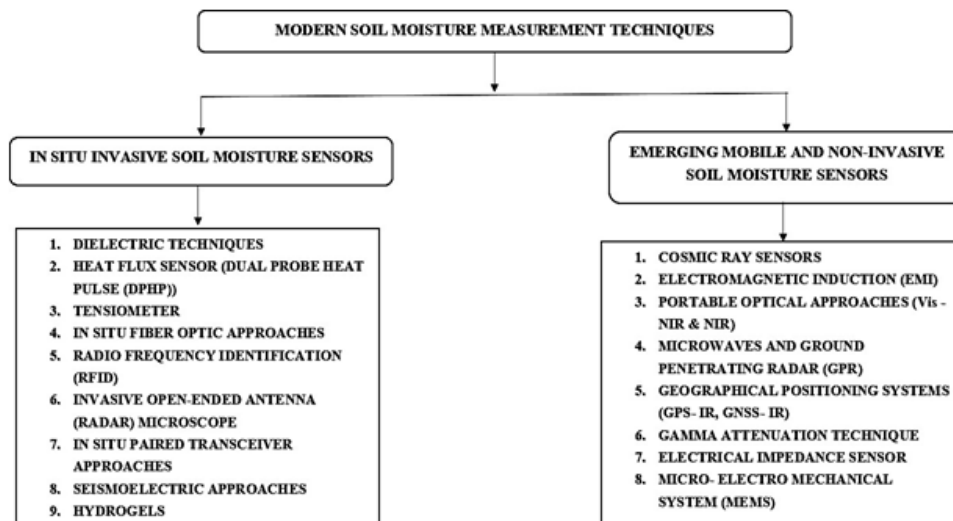

Figure 4: Modern Soil Measurement Sensors

1. In- Situ Invasive Soil Moisture Sensors:

- Dielectric Methods of Soil- Moisture Measurement:** Time Domain Reflectometry (TDR), Frequency Domain Reflectometry (FDR), and other capacitance techniques are the most important methods that exploit the dielectric properties to measure humidity and soil dampness. The principle behind this method is the huge difference between the dielectric constant value of soil and pure water. The TDR along with FDR provides more precise results in shallow soils because of the minimal effect of temperature on the estimation of electrical permittivity in the soil.
- Time Domain Reflectometry (TDR):** TDR calculates the permittivity and dielectric property in the soil-matter by estimating the delay- time between the incident and the

reflected electromagnetic waves, that is propagated as a parallel waveguide, in the system of inserted probes and conductors. The waveguides are comprised of a pair of stainless- steel rods which is fitted from the surface to a depth of 0.3 to 0.6 meters into the soil matter. The vast difference between the evident dielectric- constant of soil-water and that of the other components of the soil such as soil particle, soil mass, soil atmosphere and volumetric water content affects the travel- time of the electromagnetic pulse. Hence, TDR is advantageous due to its high progressive resolution, the repeatability of measurements, and the rapid speed of about 28 seconds in the acquisition. The frequency of operation is up to 1 GHz frequency.

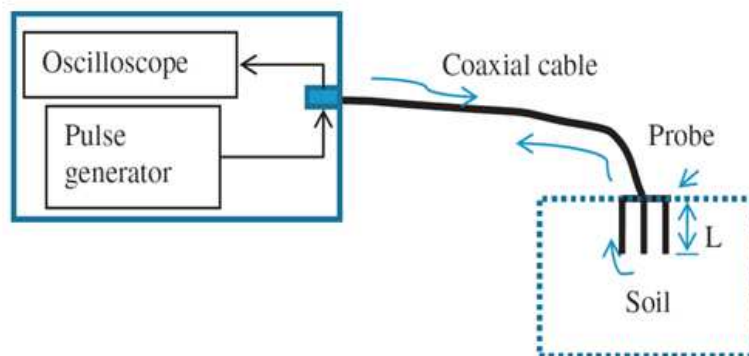

Figure 1: TDR ^[6]

- Capacitive Techniques and Frequency Domain Reflectometry (FDR):** This technique embeds a sensing module and an oscillating circuit into the soil. An operational frequency is determined by the dielectric property of the wet soil. The method estimates the number of times a capacitor charges up using the soil as a dielectric medium. A capacitor is formed by a couple of parallel electrodes in capacitance sensors. Under the operative frequency of 10 to 150 MHz, the variations in the soil moisture content are sensed due to a tuned circuit of oscillator and capacitor, working together. The FDR utilizes a sweeping frequency to collect the data over a broad range of frequencies. The concept is comparable to the capacitive technique's basic principle. These methods need to be calibrated frequently and are particular to the types of soil. These sensors have a relatively lower initial cost than TDR.

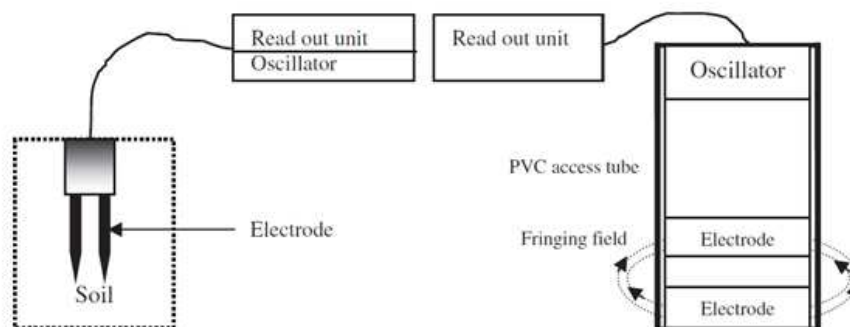

Figure 2: FDR ^[6]

- Heat Flux Sensor (Dual Probe Heat Pulse Sensor (DPHP)):** A dual probe heat pulse sensor (DPHP) is a type of heat flux sensor. This sensor comprises of 2 probes: heater and thermometer probes, used for the measurement of volumetric soil- water content. This technique depends on the exposure of an instant heat pulse to an inestimable line source. The temperature rise is detected at a short distance from the heat- line source. It has an inverse relation with the volumetric soil heat capacity and direct relation with the volumetric soil- moisture content.

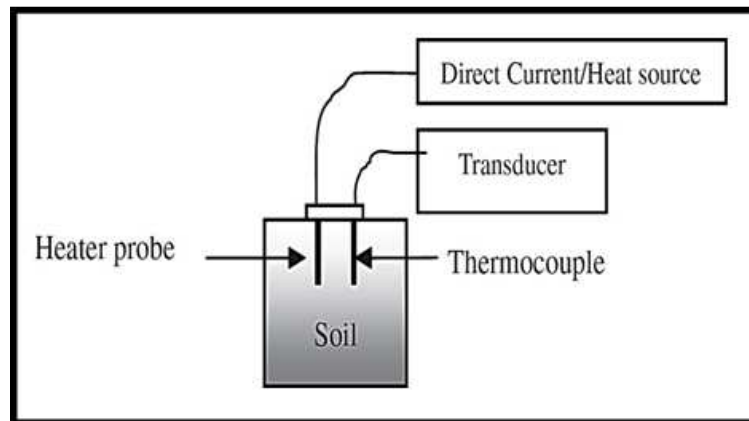

Figure 3: DPHP ^[6]

- Tensiometer:** Tensiometers are chiefly used for the measurement of capillary tension and matric potential of the soil matter. The matric potential is estimated directly using the tensiometer. The tensiometer comprises a perforated ceramic- cup that is completely filled with water and concealed inside the soil, at a required depth from the soil surface. The ceramic- cup is linked with an airtight water-contained tube connected to a vacuum device. After the tensiometer is concealed inside the soil, water from the perforated cup interacts with the soil sample and attains an equilibrium state through the perforated ceramic- cup. The loss in water-content causes a hydrostatic pressure drop, that is quantified by the vacuum device.

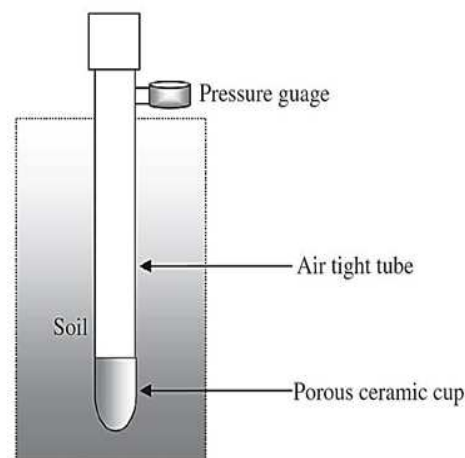

Figure 4: Tensiometer ^[6]

- Radio Frequency Identification Sensors (RFID):** An ultra high frequency radio frequency identification system (UHF RFID) functions over a broad range of frequencies (120 kHz -10 GHz). It identifies to measure the labelled objects automatically. RFID offers very cheap soil- moisture detecting devices such as discrete labels/ tags/ sensors. They can be used passively with no power. They can interconnect over a range of distances. The passive RFID sensors function by utilizing the generated energy from the reader. It provides for a unique ID and an analog potential as an output signal, that may be utilized in low-watt microcontrollers or detectors.

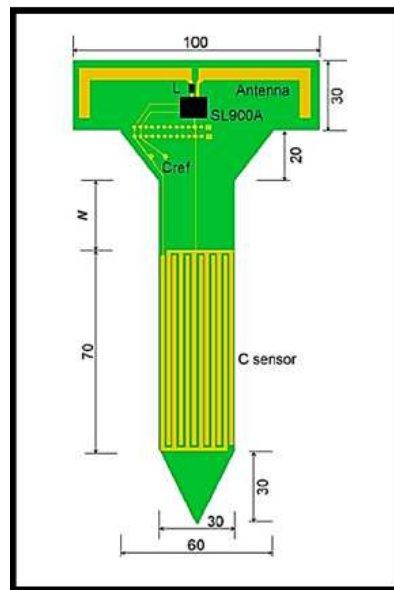

Figure 5: RFID ^[6]

- Evolving, Mobile and Non-Invasive Soil- Moisture Sensors ^[6]:** Non- invasive soil- moisture detectors are used for both mobile- mapping or point- sourcing and monitoring of the soil- water content. The mobile and non-invasive method has the potential capacity to overcome problems of inconvenient low- volume measurements, non-movable detectors, time consumption, and unreasonable estimation of moisture in larger areas. They are also operatable in stony soils, where invasive sensors offer less interaction with the soil. Disadvantages of the use of non-invasive methods include limited penetration depth, varied range of penetration- depth to the soil- water content, difficulty in separation of output signals from different layers of the soil, the survey- time, and the requirement for a high level of operational skills.

- Cosmic Rays Sensors:** Cosmic rays sensors are commercial, non- invasive, immobile detectors, that naturally estimate the neutrons radiated by cosmic rays. A neutron moisture meter is one of the cosmic ray sensors. It consists of an inert neutron detector, that is positioned at a few distance heights, above the soil surface, to measure the emission of rapid, evaporating neutrons from the soil surface, into the atmosphere. Neutrons are released by the collision of neutrons with the soil's hydrogen atoms. It is suitable for stony soils. These sensors can measure a wide ground area of approximately 520m–1200 m in diameter. Hence, they may be suited

for large-scale cultivation of crops on homogeneous soil matter. The application drift towards precision agriculture and irrigation rate variations are yet to be discovered in the aspect of these sensors.

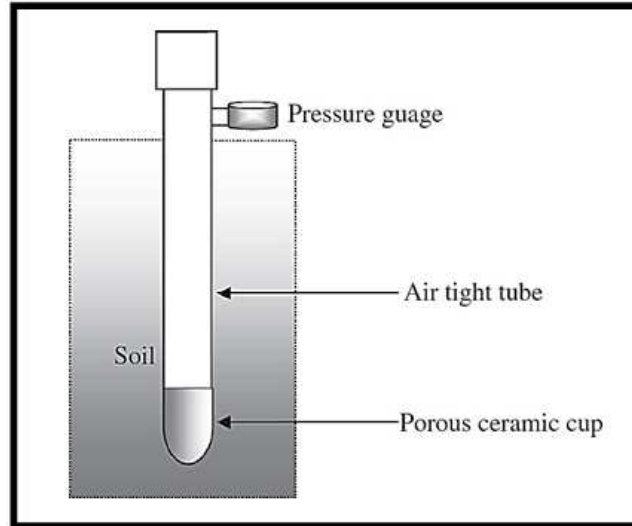

Figure 1: NMM ^[6]

- **Electro- magnetic Induction (EMI) Sensors:** Electro- magnetic induction (EMI) investigation is regularly performed in farming techniques to plot variability in soil-moisture for either the different soil types or the bulk soil. EMI surveys conducted, are easy, rapid, and non-invasive methods. They provide a high spatial resolution. Specialized skills or knowledge are not essential to process and interpret data when compared to the other physio-geological strategies (i.e., GPR, etc). EMI sensor is an indirect approach. It responds to the ions or salt concentration in the soil solution and is not directly sensitive to soil moisture. The increased soil moisture content increases the mobility of ions and further rises its apparent electrical conductivity in the soil (EC_a).
- **Portable and Optical Approaches in Soil- Moisture Detection (Vis-NIR & NIR):** Portable and optical methods involve the use of MIR, NIR, and vis-NIR, which are used to estimate a wide array of soil properties. A largely preferred approach for the measurement of soil- moisture is Vis-NIR in the range of 400–1000nm. Optical approaches are generally recommended, because of their cost efficiency, portable accessibility, and amplified tolerance for the analyte preparation. The basic principle is that the changes in the absorption spectrum result from the accumulation of water-films in clay capillaries and on the surface of the soil.
- **Microwaves- based Ground Penetrating Radar (GPR):** GPR transmits and reflects the high frequency of 1 MHz up to 1 GHz, electromagnetic microwaves within the layers of the soil. The estimations of GPR provide data regarding the dielectric-property of the subsurface in soil layers. It calculates the travel- time of the ground waves, that propagates from the source of the antenna to the receiver. This calculation is directly related to the dielectric- constant value of the soil analyte. It is a non-invasive approach of measurement with the highest resolution. It is also utilized for the

measurement of the variations in the properties of electrical permittivity over large surface areas of the ground. The application of GPR is limited, because of the requirement of high intellectual knowledge and the non-suitable range of electrical conductivity in saline soils.

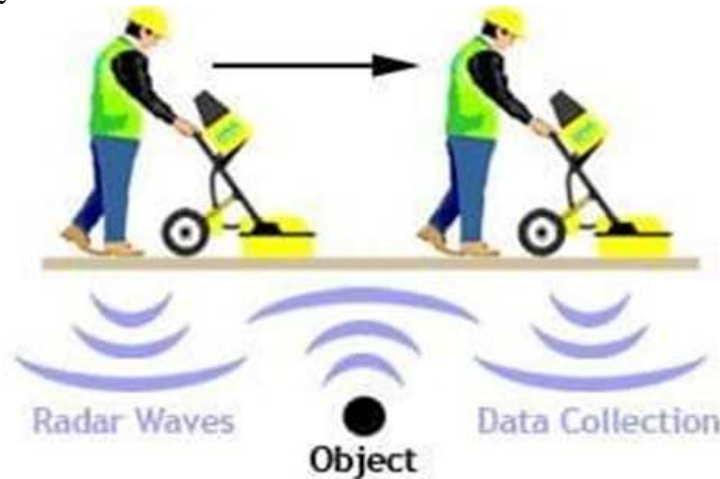

Figure 2: GPR ^[6]

- Geographical Positioning Systems (GPS- IR):** The two major strategies used in Remote Sensing as sensors are Global Navigation Satellite System interferometric reflectometry (GNSS-IR) and Geographical Positioning System interferometric reflectometry (GPS-IR). The receptors utilize the variations between the incident and the reflected L- band microwaves (1– 2 GHz frequency and 15–30 cm wavelength), to measure the dielectric constant related to soil moisture. The rise in soil- water content reduces the frequency by increasing the noise and signal of the reflected waves. The effectiveness of the calibration is highly affected by the wavelength. The L- band microwave can only enter a few millimetres into the wet soil, and up to around 0.05 m in dry soil, and the diameter of the calibrated soil ranges from about 100 m for an antenna fixed at 1-meter height to 660 m for an antenna fixed at 20-meter height. The GPS signals are far, wide, and they measure the soil- water content with the commercially accessible, manually operated receptor with a modifiable antenna height.

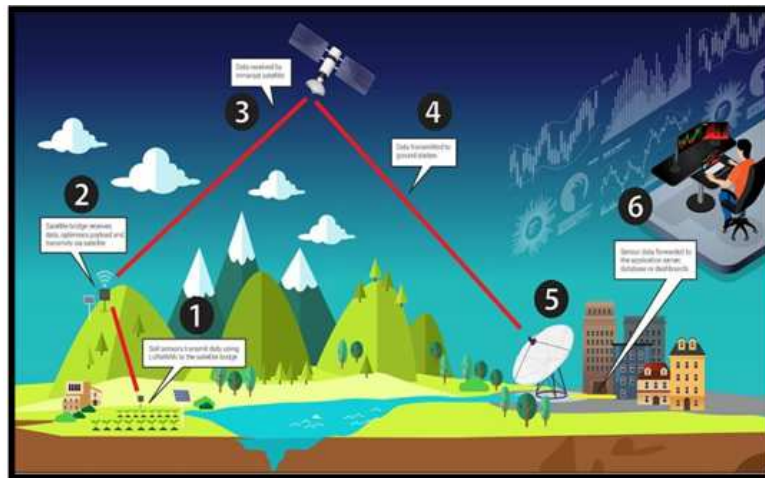

Figure 3: GPS-IR ^[6]

VII. WIRELESS SENSOR NETWORKS (WSNs) IN SOIL- MOISTURE MEASUREMENT

A wireless sensor network (WSN) is a network technology that is comprised of several sensors- nodes, that help in detecting, collecting and calibrating agricultural data. The data is obtained from the environments where the sensors are deployed and is subsequently transmitted to the users.^[7]

1. General Process of WSN:

- Collection of the soil information
- Survey of the farmland for cultivational improvement.
- Measurement of the water requirement for the crops.
- The frequent determination of the irrigation for crops.

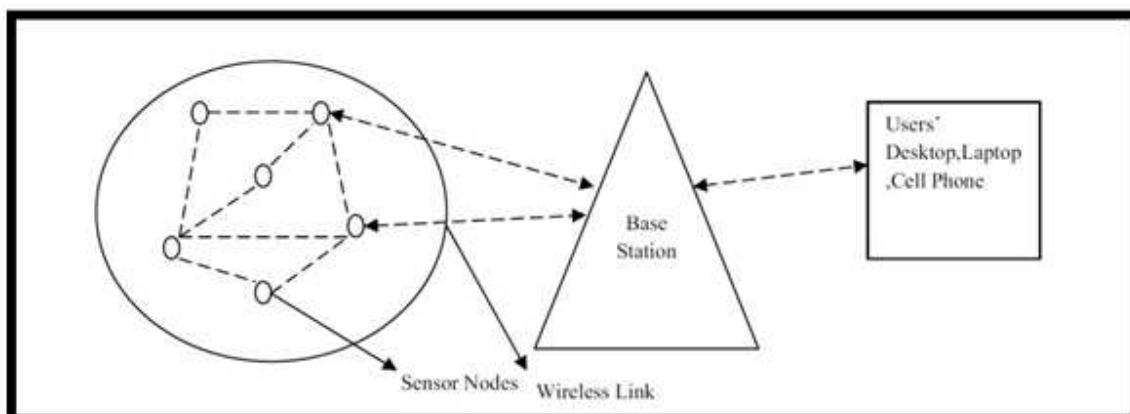

Figure 1: Overview of WSNs ^[7]

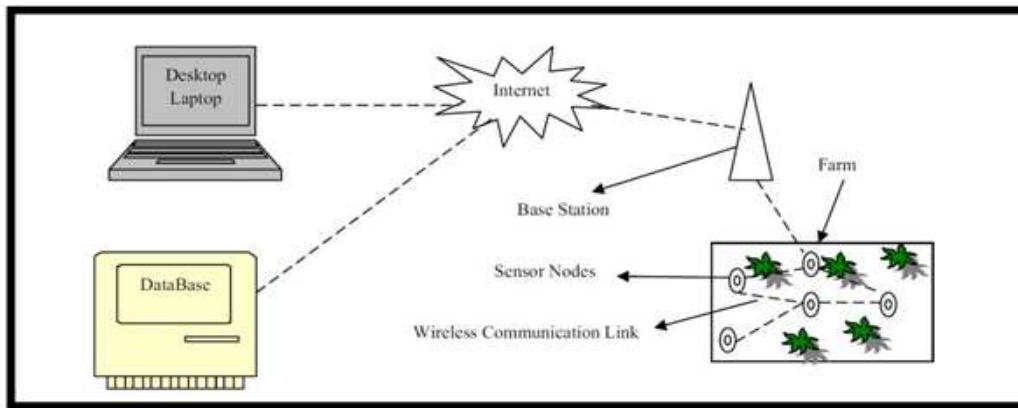

Figure 2: Overview of WSNs in Precision Agriculture ^[7]

VIII. CLASSIFICATION OF WSN

1. Categories of WSN:

- **Structured WSN:** This type of WSN is set up in a specific area and is configured easily whenever there is a problem with the sensor- nodes.
- **Unstructured WSN:** This type of WSN is set up in bulk without any sensor- network architecture. It is mainly located in areas where they are out of humans-reach to collect agricultural data.

2. Types of WSNs:

- **Terrestrial WSN** - It is installed on the surface of the ground to inspect the geological aspects of the land.
- **Underground WSN** - It is installed inside mines, caves, or under the ground to monitor the soil and moisture conditions.
- **Underwater WSN** - It is installed inside the regions of the ocean or river for the surveillance of underwater conditions.
- **Multi-Media WSN** - It is installed to collect, access and process multimedia information such as video, audio or image data.
- **Mobile WSN** - The sensor- nodes of the mobile WSN can be moved from one place to another. It is installed for monitoring the land and underwater conditions.

IX. APPLICATION OF WSN IN PRECISION AGRICULTURE

1. **Monitoring of Crops:** El-kader illustrated a precision agricultural surveillance model for potato crops.^[8] Soil testing was done using sensor nodes to check whether the land is suited for agriculture or not. It also provided improved facilities for irrigation and fertilizers.
2. **Irrigation Management:** Gutierrez proposed an automated WSN- based irrigation system for the optimization of the water utility in the farm field.^[9] It was comprised of dispersed wireless networks of soil- moisture and temperature sensors. The system was

feasible and cost-effective to minimize the amount of water required for each crop.

3. Environmental Management: Parrilla proposed an Electro-magnetic Induction based soil electric conductivity measuring system for olive groves.^[10] Both the conditions of moist and dry soil were considered. The efficiency of 48 soil analytes was discussed based on the water content and the texture of the soil.

4. WSNs Technologies In Soil Moisture Measurement:

- **Communication technologies in WSN:** ZigBee, Bluetooth, Wi-Fi, GPRS, WiMAX.
- **Soil Moisture Sensors:** EC-10HS, EC-5, ECHO-EC 20, FDS100, MTS400, 5TM sensor, TDC220 sensor, VH400 sensor, MPS-1, CS625, SEN-13322.
- **Crops grown with the application of WSN:** Broccoli crop, Orchid greenhouse, Vineyard, Potato crop, Wheat, Olive orchard.
- **Operating System for sensor nodes:** Tiny OS, Tiny OS 2.0.
- **Platform for integration of different components in WSNs:** Arduino platform.
- **Irrigation model:** Automatic Irrigation Model.

X. INTERNET OF THINGS (IoT) IN SOIL- MOISTURE MEASUREMENT

Internet of Things (IoT) is a technology, that is designed in combination with sensors, to monitor the conditions of the crop-field and automate the irrigation system. The field conditions are detected and monitored from any place. It consists of sensors and other software- technologies that collect and transmit data over the internet. This data can be accessed in other computer systems. Therefore, the Internet of Things is gradually transforming into the Internet of Plants in the current years.^[11]

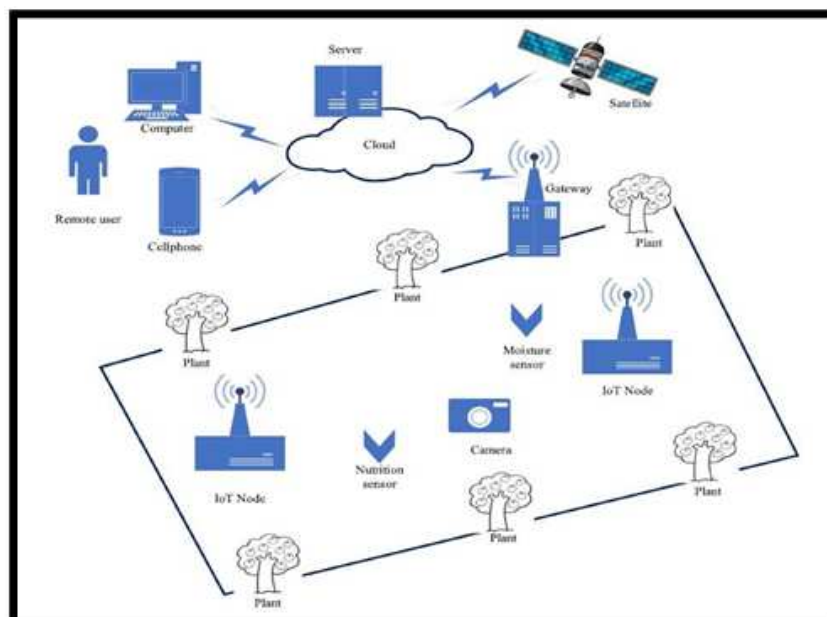

Figure 1: Overview of IoT^[11]

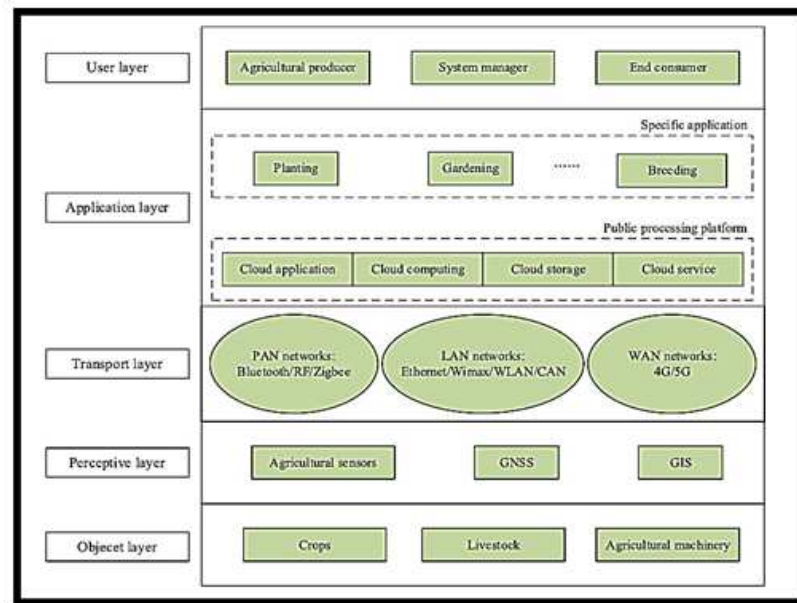

Figure 2: Architecture of Agricultural IoT ^[12]

XI. IMPORTANT TECHNOLOGIES IN AGRICULTURAL IoT ^[12]

There are various key technologies within the agricultural IoT, that assist in the detection of soil- water content. They are Sensor perception technology, Information transmission technology, Information processing technology, Radio frequency identification and 3S technology. The information is transmitted either by node location technology or wireless communication technology. The 3S technology of agricultural IoT consists of RS, GNSS and GIS techniques. These act as chief technologies in the detection of soil- moisture.

XII. SURVEILLANCE OF SOIL- MOISTURE USING CLOUD IoT COMBINED WITH ANDROID SYSTEM

The agricultural IoT process is illustrated with an FC-28 soil- moisture sensor with the Launchpad- CC3200, connected to the Wi-Fi router.^[13] The process includes the following steps:

- 1 The hardware is developed by connecting the sensor unit with the Launchpad- CC3200 to the Wi-Fi router.
- 2 The soil- water content is estimated by the sensors FC-28 and M2X.
- 3 The values are stored in an Excel sheet.
- 4 The device is connected to a public device and soil moisture data can be accessed on another system.
- 5 The soil- moisture data can be monitored by using Blynk App on Android mobile phones.

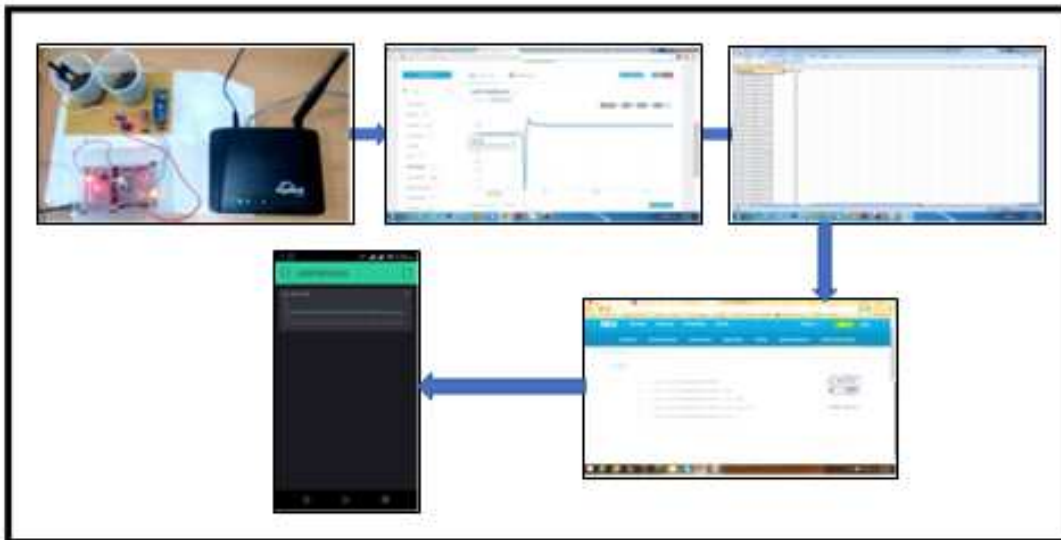

Figure 1: Process of Agricultural IoT ^[13]

XIII. REMOTE SENSING (RS) IN SOIL- MOISTURE MEASUREMENT

Remote sensing (RS) is an innovative technology in Precision Agriculture management, that gathers data to assist in environmental management. RS utilizes the electro- magnetic radiation concept to evaluate the properties of targeted soil parameters like soil moisture and texture, from a distant place. ^[14] It is proved advantageous because of its cheap cost, speed, comparatively high spatial resolution, extensiveness, non- invasiveness, timeliness, and flexibility. Great developments are made in the application of RS technology for the on-field determination of soil properties. ^[15]

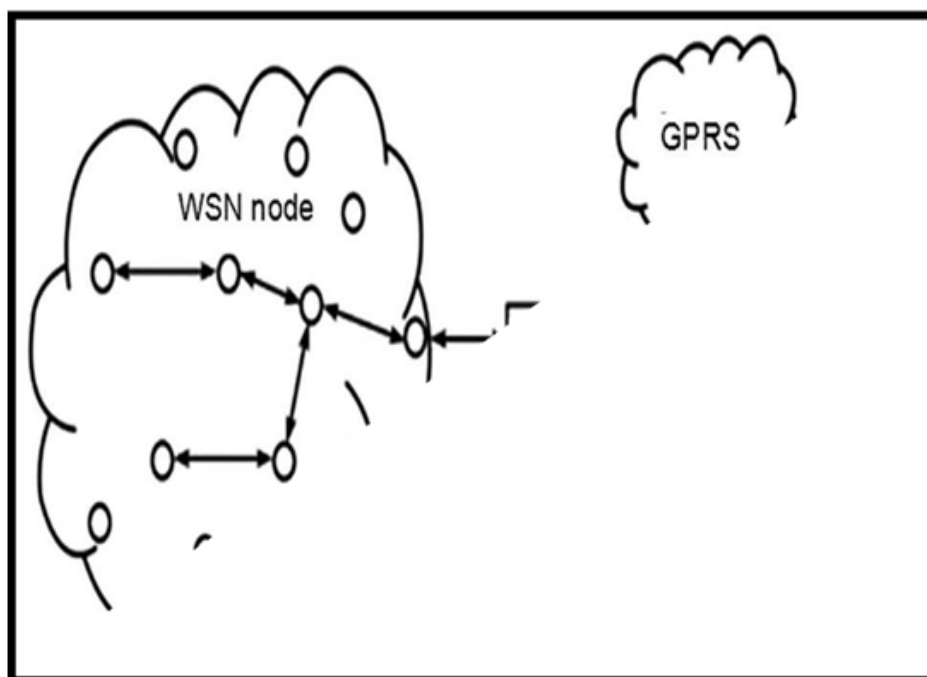

Figure 1: Overview of RS in PA ^[15]

XIV. SOURCES OF REMOTE SENSING DATA^[16]

- 1. Space- Borne Remotely Sensed Image:** Space- borne remotely sensed imaging is an empowering tool, with a high potential to generate the spatial mapping of the top-most soil layer. It evaluates the properties based on the soil- specific background interlinkages, chemical bonds and electromagnetic properties.
- 2. Air- Borne Hyperspectral Image:** Air- borne hyperspectral imaging is the most precise tool, to map the spatial soil parameters, within the agricultural- fields. The obtained data has a large area- coverage from a mission of single flight, with a suitable flight period. It can also differentiate the data into the site- segments based on the soil properties and its heterogeneity. This imaging assists in digital soil-mapping.
- 3. Unmanned Aerial System (UAS):** UAS is the latest advancement in remote sensing technology. The progress in sensors' development with advancements in dimension and spectral resolution has led to the minimal cost of both cameras and platforms. It is extensively used because of its combined features of short revisit time of space- borne and the high spatial resolution of air- borne systems. This resolution covers the diverse agricultural landscapes.

XV. PROCESS OF RS IN PA

The agricultural data gathering system is a characteristic agri-environmental information surveillance system. This system operates based on the ZigBee communication technology. This system not only resolves the irrigational problems efficiently with the soil-moisture data using WSN sensors- nodes and sensor technology but also plays a vital role in the conservation of water and improvement in performance efficiency. In this system, the sensor node compatible with the 2.4 GHz IEEE 802.15.4 is considered along with a wireless transceiver chip, CC2430, designed by the TI Chipcon Company. The base station selected is the 16/32 RISC- embedded microcontroller along with the S3C2410 chip and ARM920T kernel. The soil- water content is detected using ZigBee technology and GPRS software and recorded in the data report. This process is highly feasible and reliable for the collected soil data.

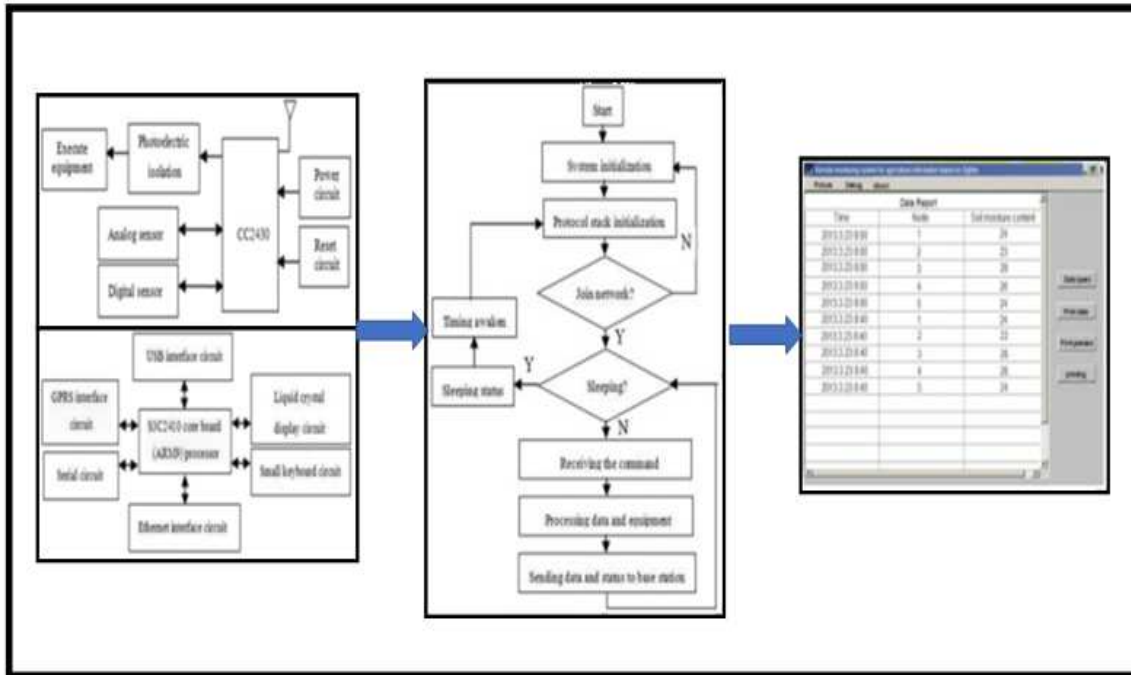

Figure 1: Process of RA in PA ^[16]

XVI. APPLICATIONS OF SMART SOIL- MOISTURE SENSORS IN PRECISION AGRICULTURE

Smart sensors are used for evaluation of soil health and optimized plant growth ^[6]. These sensors regulate and automate the irrigation management system, thus producing maximal agricultural production. These sensors, combined with advanced technologies, provide for profitability and sustainability ^[3]. Other applications include catchment hydrology, flood forecasting, landslide prediction, ecosystem services and environmental protection ^[2].

XVII. CONCLUSION

Integrated soil- moisture detection systems are utilized in Precision Agriculture for maintenance of soil- water composition and management of irrigation. The classical/conventional techniques of soil- moisture detection included the thermo- gravimetric technique, the calcium carbide chemical technique, and other spectroscopic techniques. Gradually, sensors started taking the limelight in the field of testing environmental parameters. Various invasive and non-invasive sensors are used such as TDR, FDR, DPHP, RFID, Tensiometer, GPR, GPS-IR, GNSS-IR, NMM, and MEMS. WSN, IoT, and RS are various advanced technologies used in combination with soil moisture sensors for monitoring crops, irrigation management, and environmental management. The network of sensors with either WSN, IoT or RS in Precision agriculture provides high yield, profitable and sustainable crops, thereby preserving the used resources.

REFERENCES

- [1] Praveen Barapatre, Jayantilal N. Patel; Determination of Soil Moisture using Various Sensors for Irrigation Water Management, *International Journal of Innovative Technology and Exploring Engineering (IJITEE)*, Volume-8 Issue-7 May, 2019, ISSN: 2278-3075.
- [2] Heyu Yin, Yunteng Cao, Benedetto Marelli, Xiangqun Zeng, Andrew J. Mason, Changyong Cao; Soil Sensors and Plant Wearables for Smart and Precision Agriculture, *Adv. Mater.* 2021, 2007764, DOI: 10.1002/adma.202007764.
- [3] Luca Maiolo & Davide Polese; Advances in Sensing Technologies for Smart Monitoring in Precise Agriculture, In *Proceedings of the 10th International Conference on Sensor Networks (SENSORNETS)*, pages 151-158, 2021, ISBN: 978-989-758-489-3, DOI: 10.5220/0010415401510158.
- [4] Lech Gałęzewski, Iwona Jaskulska, Dariusz Jaskulski, Arkadiusz Lewandowski, Agnieszka Szyplowska, Andrzej Wilczek & Maciej Szczepańczyk; Analysis of the need for soil moisture, salinity and temperature sensing in agriculture: a case study in Poland, *Nature portfolio*, 2021, 11:16660, DOI : <https://doi.org/10.1038/s41598-021-96182-1>.
- [5] Susha Lekshmi S.U, D.N. Singh, Maryam Shojaei Baghini; A critical review of soil moisture measurement, *S.L. S.U. et al. / Measurement* 54, 2014, 92–105, DOI : <http://dx.doi.org/10.1016/j.measurement.2014.04.007>.
- [6] Marcus Hardie; Review of Novel and Emerging Proximal Soil Moisture Sensors for Use in Agriculture, *Sensors* 2020, 20, 6934; DOI : 10.3390/s20236934.
- [7] Divyansh Thakur, Yugal Kumar, Arvind Kumar, Pradeep Kumar Singh; Applicability of Wireless Sensor Networks in Precision Agriculture: A Review, *Springer Nature*, 2019, DOI : <https://doi.org/10.1007/s11277-019-06285-2>.
- [8] El-Kader, S. M. A., & El-Basioni, B. M. M. (2013). Precision farming solution in Egypt using the wireless sensor network technology. *Egyptian Informatics Journal*, 14(3), 221–233.
- [9] Gutiérrez, J., Villa-Medina, J. F., Nieto-Garibay, A., & Porta-Gándara, M. Á. (2014). Automated irrigation system using a wireless sensor network and GPRS module. *IEEE Transactions on Instrumentation and Measurement*, 63(1), 166–176.
- [10] Pedrera-Parrilla, A., Van De Vijver, E., Van Meirvenne, M., Espejo-Pérez, A. J., Giráldez, J. V., & Vanderlinden, K. (2016). Apparent electrical conductivity measurements in an olive orchard under wet and dry soil conditions: significance for clay and soil water content mapping. *Precision Agriculture*, 17(5), 531–545.
- [11] Jinyuan Xu, Baoxing Gu, Guangzhao Tian; Review of agricultural IoT technology, *Artificial Intelligence in Agriculture*, 2022, 10– 22 .
- [12] Sanika Ratnaparkhi, Suvaid Khan, Chandrakala Arya, Shailesh Khapre, Prabhishek Singh, Manoj Diwakar, Achyut Shankar; Smart agriculture sensors in IOT: A review, *Materials Today: Proceedings*, 2020, DOI: <https://doi.org/10.1016/j.matpr.2020.11.138>.
- [13] P. Divya Vani, K. Raghavendra Rao; Measurement and Monitoring of Soil Moisture using Cloud IoT and Android System, *Indian Journal of Science and Technology*, Vol 9(31), August 2016, DOI: 10.17485/ijst/2016/v9i31/95340.
- [14] Yufeng Ge, J. Alex Thomasson, Ruixiu Sui; Remote sensing of soil properties in precision agriculture: A review, *Front. Earth Sci.* 2011, 5(3): 229–238, DOI: 10.1007/s11707-011-0175-0.
- [15] Zenglin Zhang, Pute Wu, Wenting Han, Xiaoqing Yu; Remote monitoring system for agricultural information based on wireless sensor network, *Journal of the Chinese Institute of Engineers*, 2017, Vol. 40, No. 1, 75–81, DOI: <http://dx.doi.org/10.1080/02533839.2016.1273140>.
- [16] Theodora Angelopoulou, Nikolaos Tziolas , Athanasios Balafoutis, George Zalidis, Dionysis Bochtis; Remote Sensing Techniques for Soil Organic Carbon Estimation: A Review, *Remote Sens.* 2019, 11, 676; DOI: 10.3390/rs11060676.