

PV BASED BI DIRECTIONAL NOVEL ISOLATED CONVERTER FOR EV SYSTEM

Abstract

Electric Vehicles (EV) have been compelled to play a vital role in the future transportation system due to the scarcity and increasing expense of non-renewable energy source. The increased use of EVs necessitates the installation of PV panels because of its ample amount of production and cleaner form of energy. Nevertheless, the output from PV is low due to varying climatic condition. Hence, the PV energy necessitates using a DC-DC converter design which raises the low voltage output to the required level. In this proposed system, the battery energy storage (BES) serves as a backup source of energy while the PV array electricity is the main energy source. The bidirectional control of an isolated Cuk converter incorporates the charging and discharging control of the Battery Energy Storage system. In addition to this, it enables effective power transmission with negligible input/output current ripples. The employed adaptive PI controller is used to fine-tune the Proportional Integral (PI) controller's factors to enhance the Converter's functionality and effectiveness in conditions of changing temperature and irradiance. The isolated Cuk converter is precisely administered with the employed controller, resulting in a constant DC voltage output. The controlled DC voltage is provided to the single phase VSI which feeds the output to the LC filter that attenuates output voltage ripple and reduces high frequency ripple current of the inverter switches. The bidirectional isolated Cuk Converter's effectiveness and viability for PV-based EV applications are demonstrated by the results of a thorough simulation of the proposed strategy using MATLAB. These results show outstanding reliability and robust voltage stability.

Keywords: Bidirectional Isolated CUK Converter, Adaptive PI controller, LC filter, Battery Energy Storage System (BESS), Voltage Source Inverter (VSI).

Authors

S. Marisargunam

Assistant Professor
Department of Electrical and
Electronics Engineering
PSN College of Engineering and
Technology
Tirunelveli, Tamilnadu, India.
sargunam2001@yahoo.com

K. S. Kavim

Research Scholar
Department of Electrical and
Electronics Engineering
Government College of
Engineering, Tirunelveli,
Tamilnadu, India.
kavinksk@gmail.com

L. Anbarasu

Associate Professor
Department of Electrical and
Electronics Engineering, Erode
Sengunthar Engineering College
Perundurai, India.
lanbarasu78@gmail.com

Khaliq Ahmed

Research Scholar Faculty of
Electrical Engineering, Ujjain
Engineering College
Ujjain, Madhya Pradesh, India.
khaliqahmed@yahoo.com

I. INTRODUCTION

In current era of energy crisis and escalating environmental problems necessitates the use of alternative sources in EV system to the consumption of filthy fossil fuels and non-renewable energy sources. To meet this problem, solar energy is the ideal substitute to meet the increased demand in the quest for an eco-friendly world. Solar energy is a clean, abundant source of energy that is in high demand globally. Due to its low resource requirements and wide range of applications, solar energy will eventually be more beneficial. Henceforth, it is used in EV application in a wide range. Nonetheless, the intermittent nature of RES, particularly in power-plant-based PV systems, makes meeting load demand extremely difficult [1], [2]. As a result, modern technologies, such as power electronic devices and control systems, are necessary to achieve high power conversion.

Hence, in this system, an advanced bidirectional DC-DC converter design [3] is employed to perform efficient energy conversion system from PV to power EVs. Bidirectional DC-DC converters are available in two configurations: isolated and non-isolated topology. The most fundamental and straightforward non-isolated conventional DC-DC converter architecture is the buck-boost bidirectional converter. Even though it functions well in satisfying the voltage requirement of DC/AC inverter, it has some issues like high voltage stress, hard switching and high duty-cycle operation [4]. By altering the transformer turns ratio, the novel isolated converters achieve significant voltage gain in comparison to conventional non-isolated converters. On the flip side, it has also the ability to achieve galvanic isolation and enhance equipment safety [5], [6]. Several prevalent isolated converters such as flyback, forward, half bridge and full bridge converters were used. Flyback and forward converters are excluded due to their high current ratings [7], [8]. Half bridge and full bridge DC-DC converters are the extensively used isolated converters. A full bridge DC-DC converter involves switches that are capable of managing the entire load current and the circuit won't be able to generate enough current owing to the large amount of switches and devices connected in parallel to each switch [9], [10] as opposed to a half bridge DC-DC converter, which would have saturation and eventually an over current issue [11] due to the dc offset in the transformer magnetizing current. Hence in this proposed framework, Bidirectional isolated Cuk converter is utilized to give a cost-effective solution and fulfill all design requirements. This converter has Some innate qualities that make it especially appropriate for the design aims are as follows: It is ideally suited for EV applications for three reasons: 1) merely two primary switches are required for obtaining bidirectional power flow; 2) a dc blocking capacitor is installed in series to each transformer to neutralize the dc component of the transformer magnetizing current; and 3) inductors at both ends of the power supply can regulate current and lessen ripple current.

To mitigate the problem of voltage stability in PV system, several control techniques has been adopted. Different control tactics were tested in order to optimize voltage levels by controlling the amount of active power present between the photovoltaic system and the grid. According to the findings, PI controllers were used to address this problem. Several prevalent PI controllers are extensively used to optimize the performance of the converter but it does not generate optimum result due to it nonlinearities [12]. Hence, to increase the effectiveness of the PI controller, the gain values can be tweaked using several approaches which is based on evolutionary algorithms [13] such genetic algorithm, particle swarm optimization, Ziegler Nichols, Ant colony optimization and cuckoo algorithm. Although these algorithms appear to

be good from a design standpoint, they demonstrate delayed convergence and poor search ability. The adaptive PI controller adopted in this system achieves best in tuning the parameters and results with a converter with enhanced performance.

In short, the adaptive PI controller and the suggested bidirectional isolated Cuk Converter provides an outstanding solution for PV-based EV applications. It has a constant voltage output, the highest possible power density, and barely perceptible input/output current ripples, which surpass the limits of traditional converters. The improved system response and stability provided by the adaptive PI controller ensure optimal control performance.

II. RELATED WORKS

Nafis Subhani et al [14] addresses an enhanced quadratic DC-DC boost converter using the switched-capacitor cell-based construction in order to acquire an exceptionally high voltage gain while using a low duty cycle. Without a voltage doubler circuit, the recommended converter possesses the ability of attaining output voltage gains that are quite high. The proposed converter requires two independent control power supplies since it uses two semiconductor toggle switches missing a shared base. As a result, the overall system cost is hampered for the converter applications with lesser budgets.

Aravind et al [15] introduces a new multiport converter with three primary inputs are suggested. It has shared input as well as output grounding, input sources featuring high voltage gain, and low voltage stress over switches. Numerous benefits include affordability, cost-effectiveness, and lightweight for a transformer less power supply. However, due to its intricacy, determining its final life expectancy may be more challenging. It could be less resistant to surges, impulses, and step changes in input and output, and it could require more attention to electrical noise that is conducted and radiated on the output.

Sivaprasad et al [16] presented a non-isolated dual input bridge-type dc-dc converter for hybrid energy source integration that uses two insulated-gate bipolar transistors (IGBTs) without an anti-parallel diode and two IGBTs with one as well as an inductor, a capacitor, and two IGBTs to handle the two sources. Although this converter has high voltage gain, low conduction losses and higher power density. The switches in the Bridge type DC-DC converter are under more voltage stress because of the converter's negative output voltage, and as a result switching losses are not significantly reduced.

Ting Qian et al [17] utilizes main switches and shared power transformers to combine resonant forward converters with flyback converters. The galvanic separation among the input along with output phases of both switched mode converters are supplied by a transformer. It simultaneously performs resonant conversion of energy and duty ratio management. However, the outcomes voltage is correctly retained at a constant frequency by simply changing the duration of the driving impulses.

Olympio et al [18] presents the three single-phase isolated ac-ac converters based on interleaved transformers and the dual active bridge (DAB) converter. However, the dual active bridge (DAB) DC-DC converter has concerns with higher backflow power and also places more current stress on the switch tube while running with a single-phase shift due to

the structures' ability to support diminutive filter components, bidirectional power flow, and outstanding efficacy across a broad load range.

Harini et al [19] presents a novel high gain converter architecture that has features including high gain capacity, dual-input adaptability, and maximum energy efficiency. However, it also has problems relating to the complexity of the circuit, the possibility of electromagnetic interference, and the requirement for accurate control algorithms. When determining whether this converter architecture is appropriate for off-board EV charging applications, certain factors must be taken into account.

III. PROPOSED TOPOLOGY AND ITS OPERATION

1. Description of Proposed System: In the transportation sector, the introduction of EVs greatly aids in minimizing the effects of greenhouse emissions, as well as in lowering the insufficiency of fossil fuels. To solve this issue, significant efforts are being made to find novel solutions. This paper provides a ground-breaking approach to overcoming these essential challenges, which is a PV-based EV charging system, as shown in Fig. 1. To power the electric vehicle, the proposed system uses both the PV system and the grid, assuring consistent performance and reliability. The bidirectional isolated Cuk converter which plays a pivotal role successfully handles the PV system's voltage requirements by boosting the low voltage output to the necessary level. An adaptive PI controller is used to improve the operation of the bidirectional isolated Cuk converter.

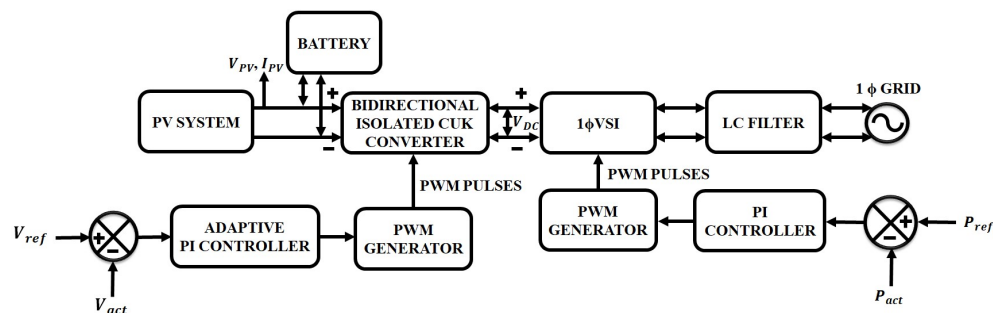

Figure 1: Proposed Block Diagram

This control strategy successfully optimizes the PI parameters using the difference between the converter's actual output voltage and the desired reference voltage level, allowing for more precise and effective system control. The controller's output is then sent into a pulse width modulation generator that creates the gating pulses necessary to power the bidirectional isolated Cuk converter. The desired output voltage is then delivered to 1 ϕ VSI. The single phase VSI which is supplied by the controlled DC voltage feed the output to the LC filter, which attenuates output voltage ripple and lowers high frequency ripple current of the inverter switches and then the power is delivered to the electric vehicle.

- 2. Modeling of PV System:** In most cases, a current source connected in parallel fashion to a couple of diodes, a shunt resistance R_p , and a resistance R_s makes up a model circuit of a photovoltaic cell. This is illustrated in Fig. 2 and the PV's output current is stated as,

$$I_c = I_{ph} - I_d - I_p \quad (1)$$

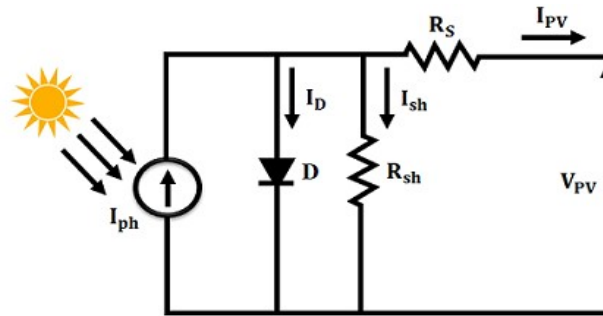

Figure 2: Schematic Equivalent Circuit Diagram of PV

Where I_{ph} indicates the produced photo current, I_d and I_p represents the current through the P-n junction and shunt resistance respectively.

The photovoltaic system is extensively used technique which transforms photons of light into electricity. Nevertheless, the performance of the PV module is impacted by changes in temperature and irradiance. The PV module's voltage and current are significantly impacted by variations in temperature and irradiance, correspondingly. Due to the earth's rotation and the sun's movement, neither factor stays constant throughout the day; consequently, a DC-DC converter is necessary to run a PV system at its peak efficiency. Bi directional isolated Cuk converter is used to boost the output of PV towards the necessary level.

- 3. Bidirectional Isolated CUK Converter:** Solar panels, a form of renewable energy, offer low output voltages. The output voltage needs to be elevated when these are linked to the high voltage bus (power grid). To address this problem, the efficient bidirectional isolated Cuk converter is used. In isolated Cuk converter, the high frequency transformer is placed between the two capacitors C_1 and C_2 . It's a DC-DC converter which involves best characteristics are: In addition to being a key feature of current imposition, the input with current source attribute helps to absorb sudden fluctuations in input voltage, utilizes capacitive exchange of energy among the input and output facilitates seclusion employing transformers without the requirement for a gap, such as in toroidal cores with low levels of dispersion inductance, and furthermore helps to reduce unwanted voltage peaks in semiconductors. Apart from this, it features significant output voltage range as well as minimal input current ripple. The isolated Cuk converter when works in CCM, it involves couple of modes.

IV. MODES OF OPERATION

Mode 1: As soon as S_1 , the switch, is activated, the power from the source retained by the capacitor C_a gets transmitted onto the transformer, creating a current that is negative in the input coil and a positive current in the output. Then this current traverses by means of the capacitor c_b and discharges into the inductor L_{12} , the capacitor C_0 , and the charge R_o .

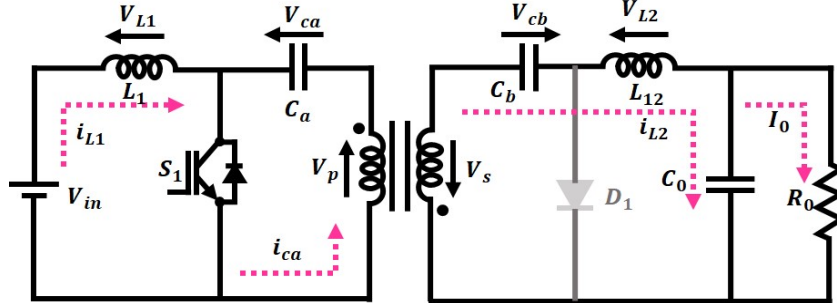

Figure 3: Circuit Diagram of Mode 1 Operation

Mode 2: The main source and the power collected in the inductor L_1 flow through C_a , once S_1 (the switch) is flipped down resulting in an electrical current that is positive in the input coil of the transformer and a resulting negative current in the output coil. D_1 (diode) gets polarized next, leading to discharge in the load R_o , capacitor C_0 as well as inductor L_{12} .

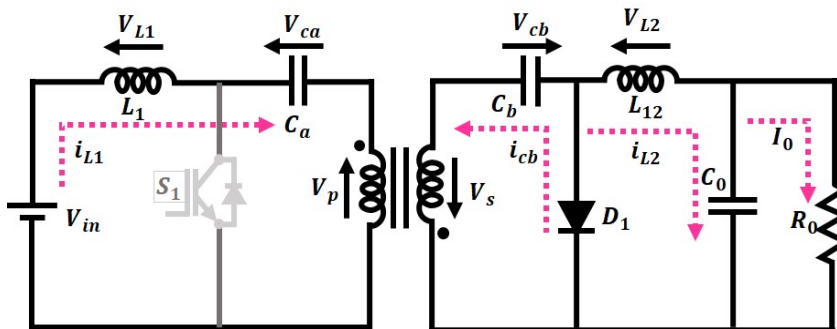

Figure 4: Circuit Diagram of Mode 2 Operation

The relationship of input-output voltage is given by,

$$V_{out} = \left[\frac{D}{1-D} \right] V_{in} \quad (2)$$

The corresponding output current relationship is expressed as

$$I_{out} = \left[\frac{1-D}{D} \right] I_{in} \quad (3)$$

To optimize the performance of bidirectional isolated Cuk converter, adaptive PI controller is used which possess improved voltage stability and control the active power present between Photovoltaic system and the power grid

- Adaptive PI Controller:** In order to regulate how the isolated cuk converter switches, the PI controller is essential. It makes sure that the resulting voltage closely resembles the reference voltage. Prevalent PI controllers rely on consistent values of proportional (K_p) and integral gains (K_i), they cannot effectively deal with unexpected disturbances, parametric fluctuations, and model uncertainties. Adaptive-PI (A-PI) controllers alter their parameters and gains to address this issue. Based upon the error function, the control parameters are adjusted using fuzzy rules which is followed below,

If absolute error $|e(t)|$ is minimum, then K_i is zero and K_p becomes maximum.

If $|e(t)|$ is maximum, then K_i and K_p becomes greater.

If $|e(t)|=0$, then K_i is minimum and K_p becomes maximum.

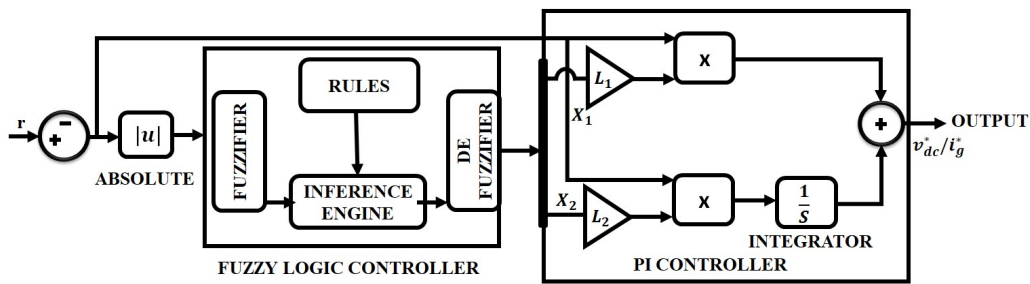

Figure 5: Adaptive PI Controller

The mathematical expression of Gaussian membership function in Fuzzy Logic Controller (FLC) is computed as,

$$\mu(x) = \exp\left(-\frac{1}{2}\left(\frac{x_i - c_i}{\sigma_i}\right)^2\right) \quad (4)$$

Where C_i and σ_i in the equation represents the center and variance respectively.

The expression of PI controller is given by,

$$\frac{v_{dc}^*}{i_g^*(fuzzy)} = X_1 L_1 e(t) + X_2 L_2 \int e(t) dt \quad (5)$$

Where K_p and K_i indicates the proportional and integral gains, $e(t)$ is the input provided to the controller and v^*DC/i_g is the resulting output of the controller. The aforementioned equation clearly shows that the K_p and K_i values are not constant and are unable to regulate parameter uncertainties, load changes, disturbances, and electrical faults. These issues are met by adaptive fuzzy-PI controller because it uses adaptive gains and it is expressed as,

$$\frac{v^*DC}{i_g^*(fuzzy)} = X_1 L_1 e(t) + X_2 L_2 \int e(t) dt \quad (6)$$

Where X_1 and X_2 in the equation denotes the fuzzy logic controller output and L_1, L_2 represents the constant learning rate for the K_p and K_i gains respectively. The

controller's output signal is then routed to a PWM generator, which is in charge of generating precise gating pulses. These gating pulses effectively govern the isolated Cuk converter's switching function. The isolated cuk converter's stable voltage output is then effortlessly fed to 1φ VSI. LC filter receives input from inverter's output that attenuates the output voltage ripple and minimizes the high frequency ripple current of the inverter switches and finally it directs the power to the grid to power the electric vehicle.

V. RESULT AND DISCUSSION

This work develops a novel adaptive PI-controlled bidirectional isolated Cuk converter that supports both PV and EV applications. The proposed system is evaluated using MATLAB simulation to ascertain its performance under varying condition. Temperature and irradiance, two important elements impacting the effectiveness and stability of the system, are taken into account in the simulation. The parameter specifications provided in Table 1

Table 1: Parameter Specification

PV system	
Peak power	100W, 15panels
Short current circuit (I_{sc})	5.86 A
Open voltage circuit (V_{oc})	22.68 V
Isolated CUK Converter	
SWITCH-MOSFET	10KHZ
$L_1 L_2$	1mH
C_a, C_b	4.7 μ f
C_o	22 μ f

Figures 6(a) and (b) illustrate the waveforms of temperature and solar irradiation, accordingly. The graph shows that, in order to evaluate the system's functionality, the sun intensity is increased from 800 W/m² to 1000 W/m² in 0.1s while the changes from 25°C to 30°C in temperature occurs.

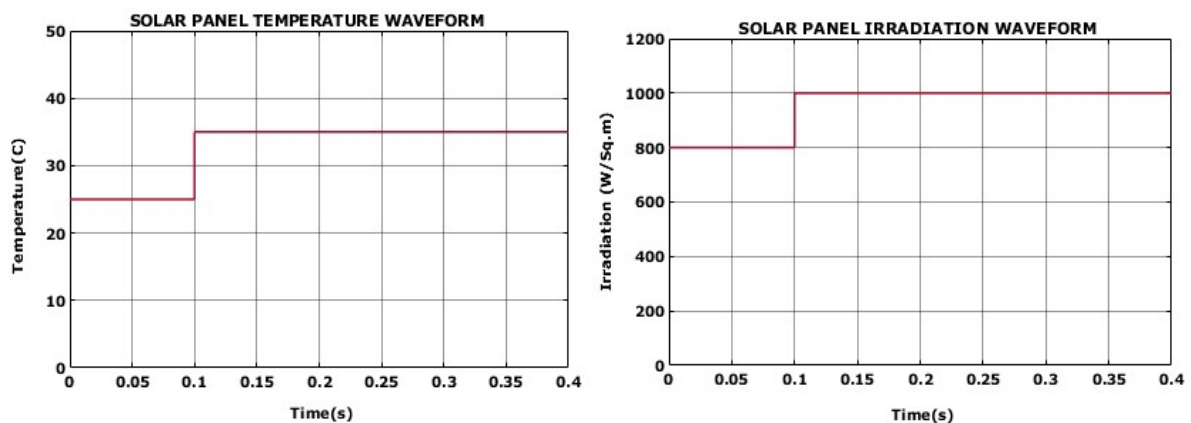

Figure 6 (a): Temperature waveform of solar panel

Figure 6 (b): Irradiation waveform of solar panel

Figure 7 (a) and 7 (b) shows how resulting voltage as well as resulting current of PV panels is affected by variations in temperature and solar radiation. The solar panel's output voltage starts out at 48V and changes to 60V in 0.1s due to a change in operating conditions. Similar to this, the PV-generated current hits 12 A at 0.1s after slight fluctuation.

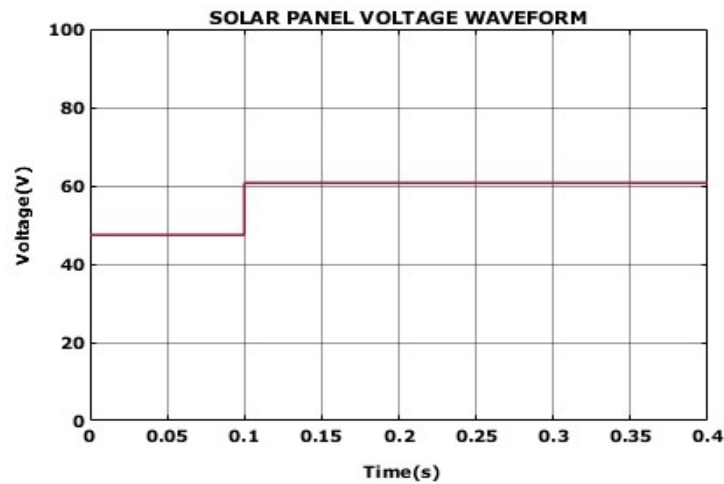

Figure 7(a): Voltage Waveform of Solar Panel

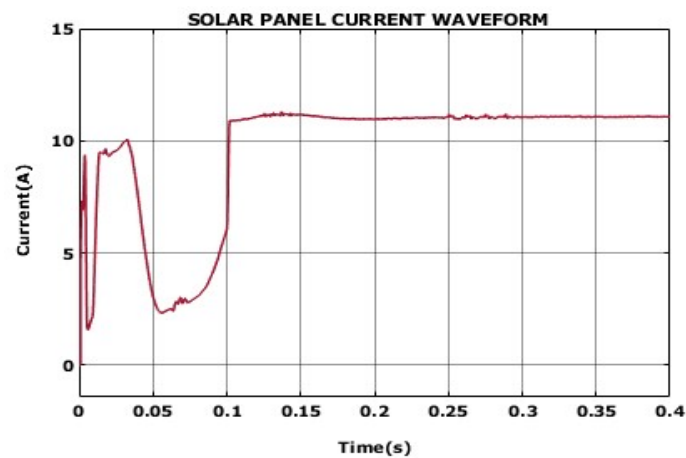

Figure 7(b): Current Waveform of Solar Panel

To demonstrate the dynamic performance, the isolated Cuk converter and its recommended control method are put to the test. When examining the waveforms of the PV panels shown in figures 7 (a) and (b), it becomes clear that the abrupt changes in temperature and irradiation have an immediate effect on the PV panel's resultant voltage as well as current. The isolated Cuk converter generates a constant 300V at its output. With the use of PI controller the voltage variation in its input has no impact on its output. Converter with adaptive PI controller represented in figure 8(b) shows that it is highly effective in delivering the stable output voltage whereas the converter with PI controller exhibits fluctuation and ripples at the output which is shown in figure 8(a).

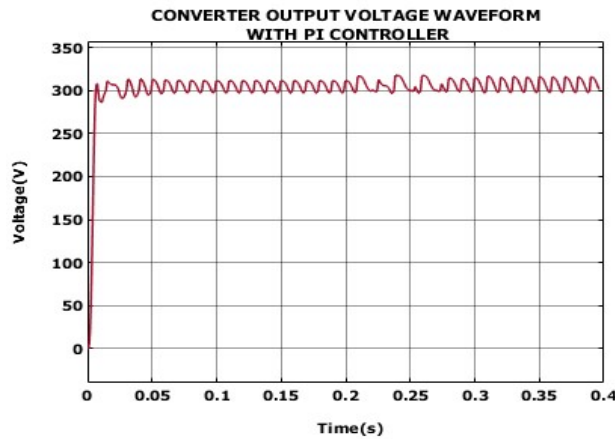

Figure 8(a): Waveform of Converter Output Voltage

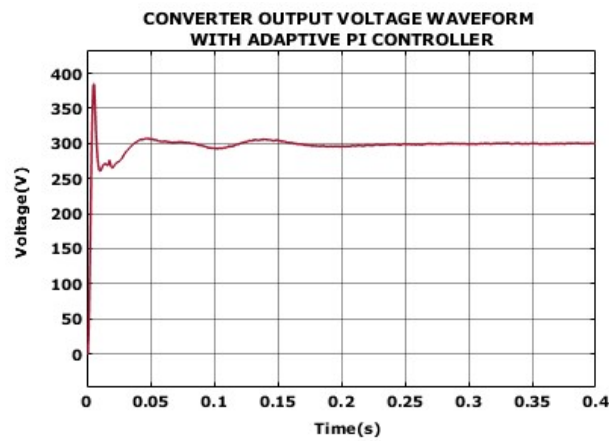

Figure 8(b): Waveform of Converter Output Voltage with PI Controller with Adaptive PI Controller

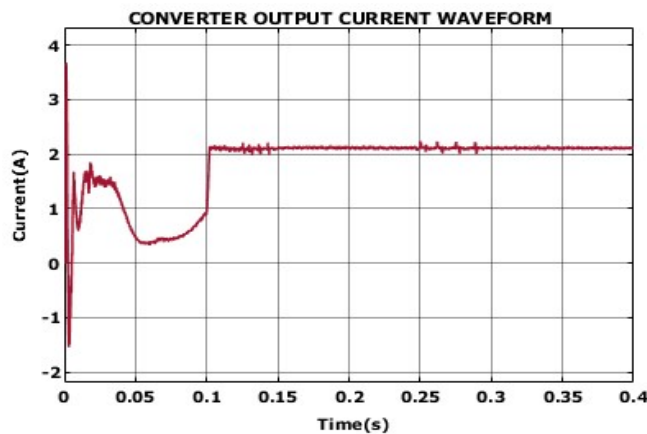

Figure 8(c): Waveform of Converter Output Current

Figure 9 (a), (b) and (c) shows the output waveform of battery SOC, current and voltage waveform respectively. The output current waveform of the battery shows negative spike in the initial stage and after it remains constant because the state of charge (SOC) is

maintained stable at 60% whereas the output voltage value reaches to 26 volt and stability is maintained which is shown in figure 9(c).

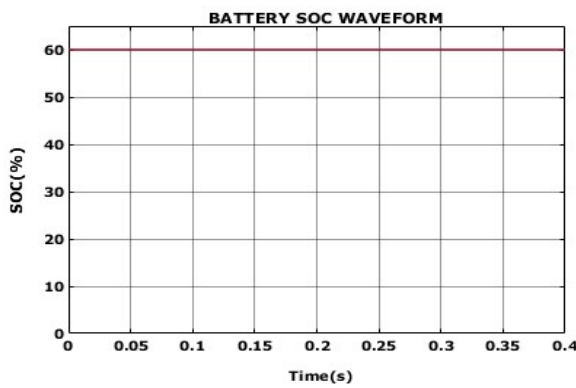

Figure 9(a): Battery SOC Waveform

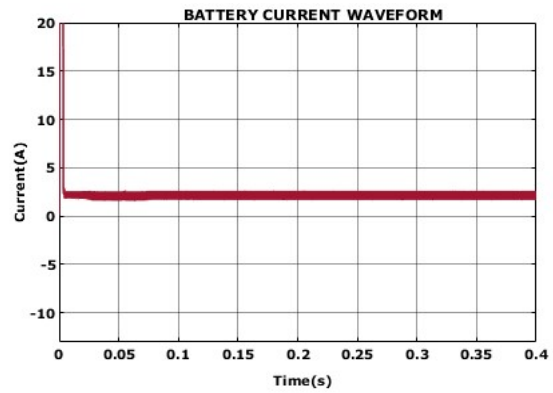

Figure 9(b): Battery Current Waveform

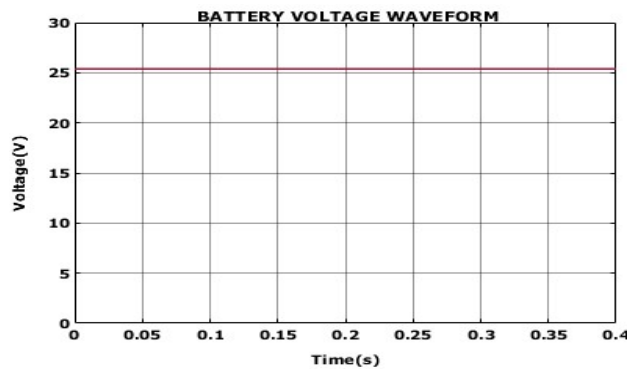

Figure 9(c): Voltage Waveform of Battery

The grid voltage and grid current waveforms from the single-phase grid are evaluated for stability in addition to being analyzed as part of the isolated Cuk converter's voltage output waveform. Using a grid voltage synchronization technique based on PI controller, this evaluation is conducted. The grid voltage and grid current waveforms display impressive stability as illustrated in Fig. 10(a) and (b) correspondingly, due to the use of the PI controller.

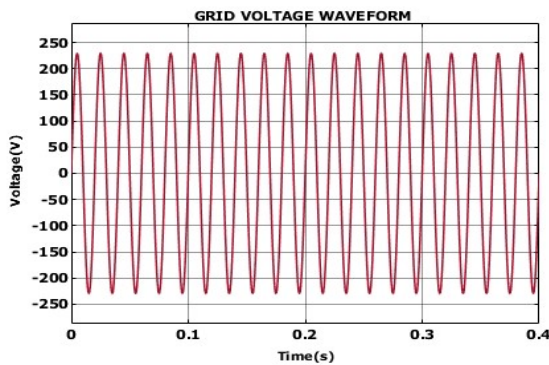

Figure 10(a): Waveform of Grid Voltage

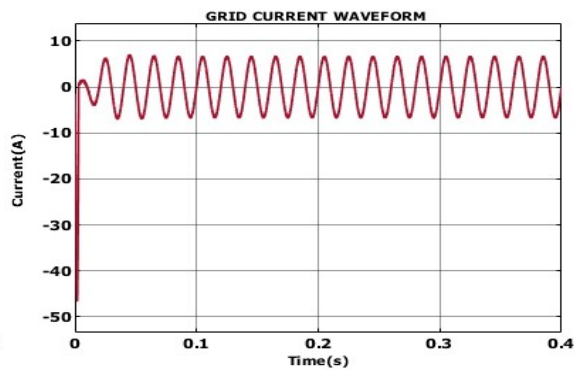

Figure 10(b): Waveform of Grid Current

Figure 11 (a) and (b) shows the waveform of real and reactive power respectively. While the reactive power is seen to be insufficient, the real power is recorded to be 750W.

Here, the PV-based EV system benefits from the controlled and limited reactive power consumption since it enables the best possible use of the available power resources

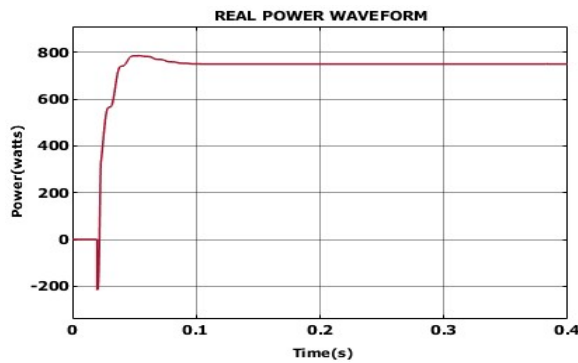

Figure 11(a): Waveform of Real Power

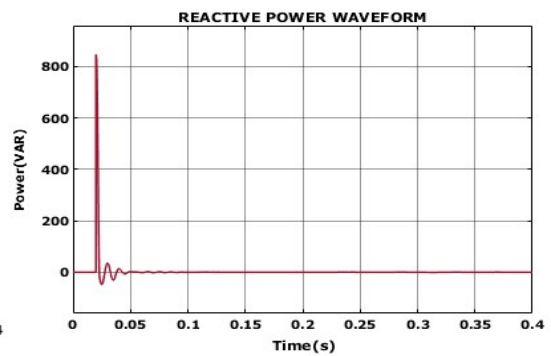

Figure 11(b): Waveform of Reactive Power

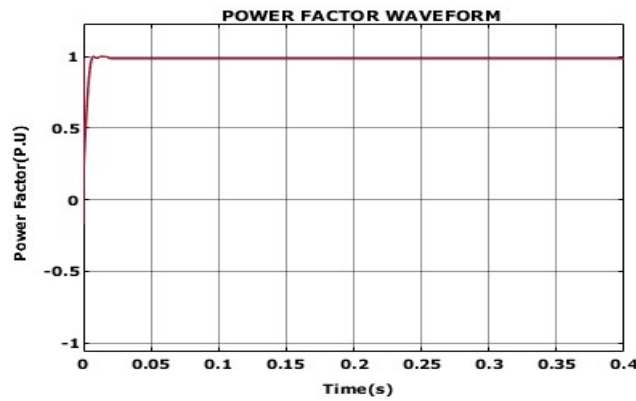

Figure 12: Waveform of Power Factor

The waveform of power factor is represented in figure 12. It clearly illustrates that the ideal power factor, unity is achieved which results in the most efficient loading of the power supply.

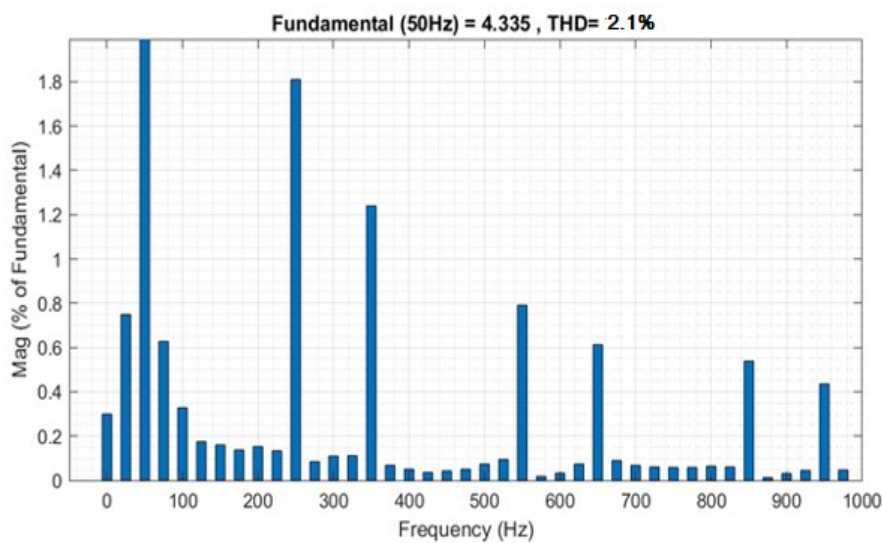

Figure 13: Total Harmonic Distortion

The Total Harmonic Distortion graph is represented in figure 13 and in figure 14, comparison is made with other converters. Compared to other converters, the isolated Cuk converter achieved low THD value of 2.1%. It indicates the efficacy of the suggested method in minimizing harmonic distortion. Using the efficient isolated Cuk converter with adaptive PI controller, the presence of harmonics is minimized and the overall power quality gets improved.

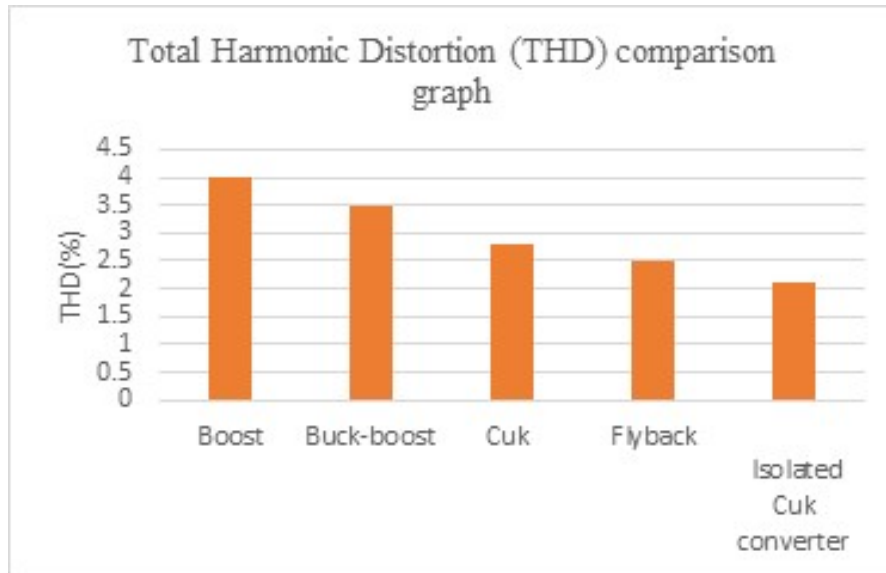

Figure 14: THD Comparison Graph

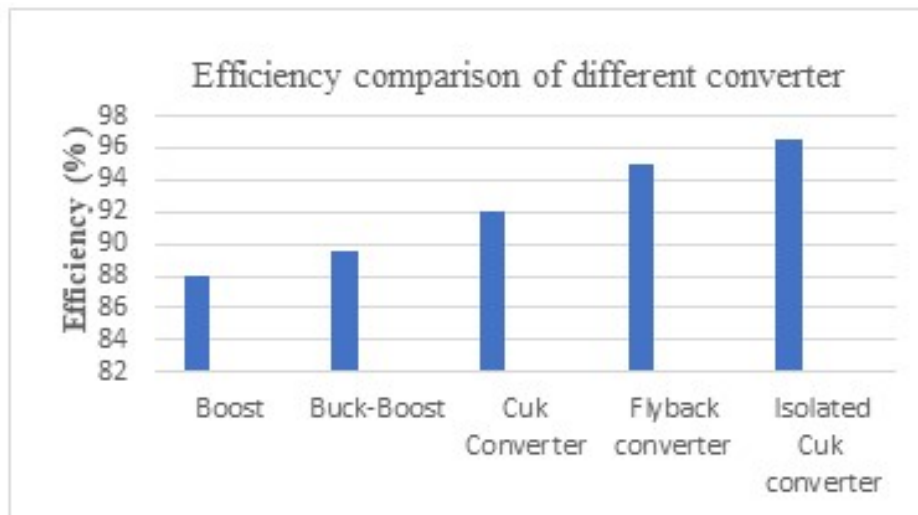

Figure 15: Efficiency Comparison of Different Converters

According to the comparison graph in Fig. 14, the isolated Cuk converter achieves the highest efficiency of 96.5%, indicating that it is highly effective in delivering the desired output power with minimal losses. It outperforms the other converters and it is used in high power applications such as PV-based EV charging systems.

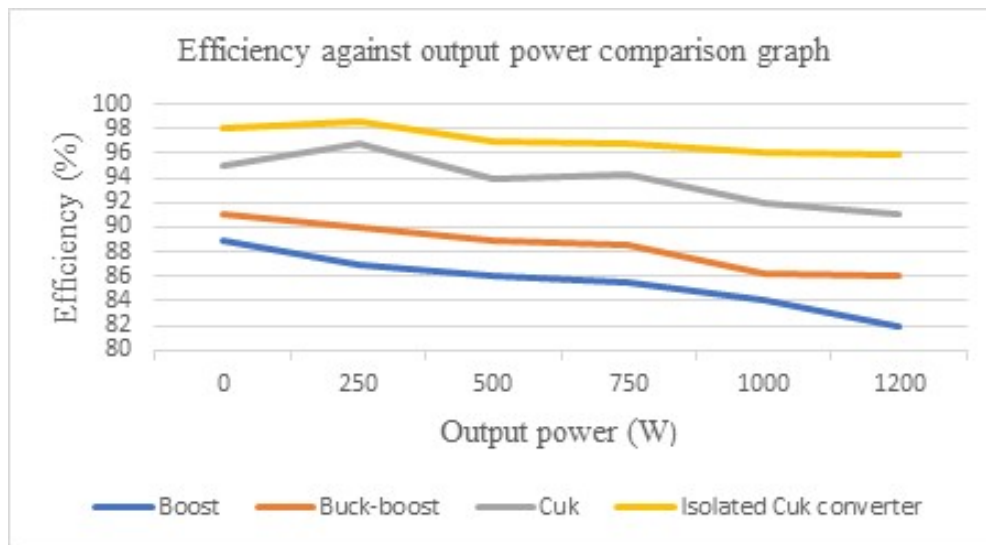

Figure 16: Efficiency against Output Power Comparison Graph

The efficiency against output power comparison graph is shown in figure 16. It clearly illustrates that the isolated Cuk converter achieves higher efficiency of 98 % in delivering the output power. It outperforms the other converter in delivering the high output power.

VI. CONCLUSION

Electric vehicles (EVs) have the potential to revolutionize transport and protect the world from imminent climate-related catastrophes. They are regarded as a feasible option for conventional vehicles that depend on depleting fossil resources. In the suggested framework, a bidirectional isolated CUK converter with an integrated adaptive PI controller is used to power the EV more effectively. According to the simulation results, the used approach outperforms other converter topologies in terms of maximum power density, negligible input/output current ripples, and efficient power transmission. Additionally, the adaptive PI controller improves the system's response by giving the converter a stable output voltage. The usefulness of the PI is further demonstrated by the consistency of grid voltage synchronization and the minimal reactive power requirements.

REFERENCE

- [1] Shailendra Kumar Tiwari, Bhim Singh, Puneet Kr. Goel 2018, "Design and Control of Microgrid Fed by Renewable Energy Generating Sources", IEEE Transactions on Industry Applications, vol. 54, no. 3, pp. 2041-2050.
- [2] Yashi Singh, Bhim Singh, Sukumar Mishra 2022, "An Uninterruptable PV Array-Battery Based System Operating in Different Power Modes With Enhanced Power Quality", IEEE Transactions on Industrial Electronics, vol. 69, no. 4, pp. 3631-3642.
- [3] Saman A. Gorji, Hosein G. Sahebi, Mehran Ektesabi, Ahmad B. Rad 2019, "Topologies and Control Schemes of Bidirectional DC-DC Power Converters: An Overview", IEEE Access, vol. 7, no. 8, pp. 117997-118019.
- [4] Balaji Chandrasekar, Chellammal Nallaperumal, Sanjeevikumar Padmanaban, Mahajan Sagar Bhaskar, Jens Bo Holm-Nielsen, Zbigniew Leonowicz, Samson O. Masebinu 2020, "Non-Isolated High-Gain Triple Port DC-DC Buck-Boost Converter With Positive Output Voltage for Photovoltaic Applications", IEEE Access, vol. 8, no. 6, pp. 113649-113666.

- [5] Tian Cheng, Dylan Dah-Chuan Lu, Ling Qin 2018, "Non-Isolated Single-Inductor DC/DC Converter With Fully Reconfigurable Structure for Renewable Energy Applications", IEEE Transactions on Circuits and Systems II: Express Briefs, vol. 65, no. 3, pp. 351-355.
- [6] Jianwu Zeng, Wei Qiao, Liyan Qu 2015, "An Isolated Three-Port Bidirectional DC-DC Converter for Photovoltaic Systems With Energy Storage", IEEE Transactions on Industry Applications, vol. 51, no. 4, pp. 3493-3503.
- [7] Giorgio Spiazzi, Simone Buso 2021, "Extended Analysis of the Asymmetrical Half-Bridge Flyback Converter", IEEE Transactions on Power Electronics, vol. 36, no.7, pp. 7956-7964.
- [8] Mohammad Ali Saket, Martin Ordonez, Navid Shafiei 2018, "Planar Transformers With Near-Zero Common-Mode Noise for Flyback and Forward Converters", IEEE Transactions on Power Electronics, vol. 33, no. 2, pp. 1554-1571.
- [9] Sen-Tung Wu, Bo-Yu Yang 2023, "Design and Implementation of an Isolated Bidirectional Phase-Shift Full-Bridge Converter with High Transformation Ratio", IEEE Access, vol. 11, no. 2, pp. 17945-17955.
- [10] Manuel Escudero, David Meneses, Noel Rodriguez, Diego Pedro Morales 2020, "Modulation Scheme for the Bidirectional Operation of the Phase-Shift Full-Bridge Power Converter", IEEE Transactions on Power Electronics, vol. 35, no. 2, pp. 1377-1391.
- [11] Matthias Schulz, Stefan Ditze 2022, "Analysis and Experimental Verification of an Isolated Half-Bridge Bidirectional DC-DC Converter", IEEE Transactions on Power Electronics, vol.37, no. 5, pp. 5089-5106.
- [12] Mohamed I. Mosaad, Haitham Saad Mohamed Ramadan, Mansour Aljohani, Mohamed F. El-Naggar, Sherif S. M. Ghoneim 2021, "Near-Optimal PI Controllers of STATCOM for Efficient Hybrid Renewable Power System", IEEE Access, vol. 9, no. 2, pp. 34119-34130.
- [13] Evren Isen 2022, "Determination of Different Types of Controller Parameters Using Metaheuristic Optimization Algorithms for Buck Converter Systems", IEEE Access, vol. 10, no.12, pp. 127984-127995.
- [14] Nafis Subhani, Zazilah May, Md. Khorshed Alam, Irfan Khan, Md. Alamgir Hossain, Sabrina Mamun 2023, "An Improved Non-Isolated Quadratic DC-DC Boost Converter With Ultra High Gain Ability", IEEE Access, vol. 11, no. 2, pp. 11350-11363.
- [15] R. Aravind, Bharatiraja Chokkalingam, Lucian Mihet-Popa 2023, "A Transformerless Non-Isolated Multi-Port DC-DC Converter for Hybrid Energy Applications", IEEE Access, vol. 11, no. 5, pp. 52050-52065.
- [16] Sivaprasad Athikkal, Gangavarapu Guru Kumar, Kumaravel Sundaramoorthy, Ashok Sankar 2019, "A Non-Isolated Bridge-Type DC-DC Converter for Hybrid Energy Source Integration", IEEE Transactions on Industry Applications, vol. 5, no. 5, pp. 4033-4043.
- [17] Ting Qian, Qichen Wu 2018, "A Scheme of a Resonant Forward-Flyback Converter with Suppressed Frequency Variation", IEEE Transactions on Power Electronics, vol. 33, no.5, pp. 3711-3716.
- [18] Olympio Cipriano da Silva Filho, Fernando Lessa Tofoli, Dalton de Araújo Honório, Luiz Henrique Silva Colado Barreto, Demercil de Souza Oliveira 2022, "Single-Phase Isolated AC-AC Converters Based on the Dual Active Bridge Converter", IEEE Transactions on Industrial Electronics, vol.69, no. 6, pp. 5680-5689.
- [19] Harini, S., N. Chellammal, Bharatiraja Chokkalingam, and Lucian Mihet-Popa. "A Novel High Gain Dual Input Single Output Z-Quasi Resonant (ZQR) DC/DC Converter for Off-Board EV Charging." IEEE Access 10 (2022): 83350-83367.