

# ASSOCIATING THE EVOLUTION OF MOBILE COMMUNICATION TECHNOLOGIES AND THE INTERACTIONS OF SOCIAL NETWORKS

## Abstract

The very first interaction among human beings was gestures. In the course of time Man invented sounds, languages, communication etc. Telecommunication was the greatest one among his innovation. Man was transformed from telephone to cellular technology in the year of 1973. Now a days it had become fashion connecting with unknown people through social networks. As technology grows our world shrinks every minute. This paper aims to state the evolution of mobile technology and the use of social networks in terms of interaction and also analyse the pros and cons of social interactions.

**Keywords:** Social networks, Mobile Technology

## Author

**S.Muthumari**

Assistant Professor

Computer Science and Information  
Technology

S.S.Duraisamy Nadar Mariammal College  
Kovilpatti, TamilNadu, India.

muthu0903@gmail.com

## I. INTRODUCTION

Communication technologies have heartened the information flow and there is no boundary with the use of mobile communication[1]. Telecommunication needed some fixed place for the telephone and it was some what very costly and was not as comfortable to man. The word mobile means capable of moved or being moved. That is man can communicate with anyone while he is moving towards any place. The technology changed from wire communication to wireless communication[2]. At present, a new trend social media has been evolved among the young society to interact with others that is also unknown people. Here, We have just explained some mobile communication technologies and the social networks.

## II. MOBILE COMMUNICATION

The cell phone is a mechanical development that has changed current urban communities into continuous frameworks that continually screen natural conditions critical to the activity of the construction[8]. There were over 1.15 billion remote versatile supporters across India toward the finish of 2021.

1. History of Mobile communication Early cell phone frameworks looked like transmission frameworks, in that strong transmitters were utilized to cover a distance of 20-30 miles from a high pinnacle or roof[5]. The principal cell framework in the U.S. was placed into activity by the Ringer Framework in Chicago, in 1983, as a feature of a fast organization plan. The ideas of recurrence reuse and handoff, as well as various different ideas that shaped the premise of present day cell innovation, were portrayed in the last part of the 1960s, in papers by Frenkiel and Doorman[9].

### 2. Mobile Phone Generations

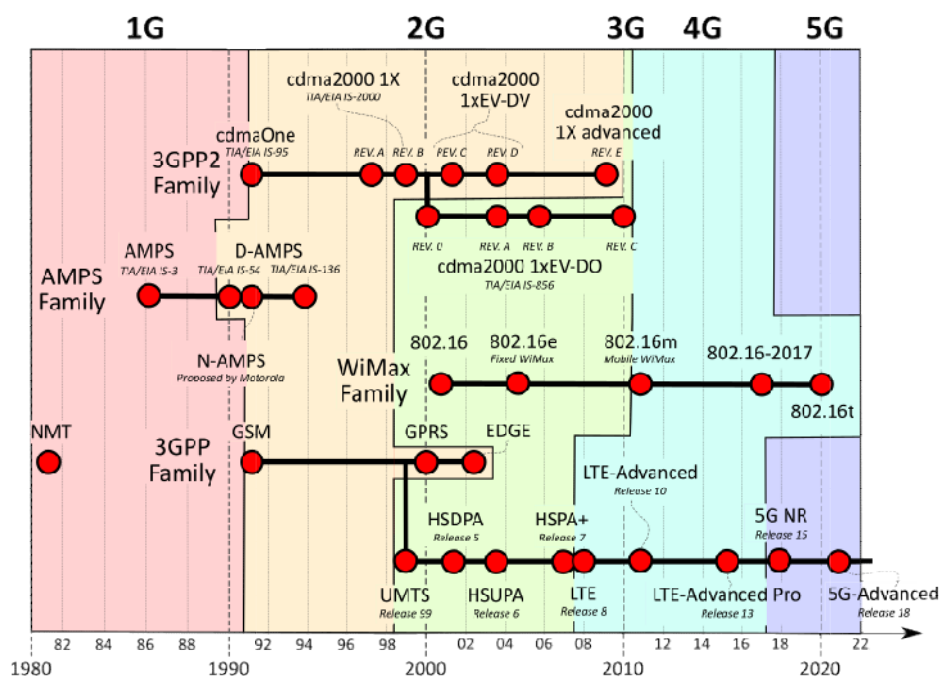

Figure 1: Cellular Network Generations

- **1G Technology:** 1G refers to first generation mobile phone technology that used analog telecommunications standard. It was introduced in early 1979.
- **2G Technology:** 2G refers to second generation mobile phone technology that used with digital encryptions. And also it was better than 1G and enabled the facility of plain text messages called SMS. This second generation launched GSM (Global System for Mobile Communications) standards. In this period TDMA was transformed with CDMA and in 2.5G General Packet Radio Service or GPRS was introduced[3]
- **3G Technology:** 3G innovation gives a data move pace of no less than 144 kbit/s. Later 3G deliveries, frequently meant 3.5G and 3.75G, additionally give portable broadband access of a few Mbit/s to cell phones and versatile modems in PCs. CDMA2000 is a group of 3G portable innovation norms for sending voice, information, and flagging information between cell phones and cell locales[5].
- **4G Technology:** 4G gives, notwithstanding the typical voice and different administrations of 3G, versatile broadband Web access, for instance to workstations with remote modems, to cell phones, and to other cell phones. Potential and current applications incorporate revised portable web access, IP communication, gaming administrations, top quality versatile television, video conferencing, 3D TV, and distributed computing[7].
- **5G Technology:** 5G remote innovation is intended to convey higher multi-Gbps top information speeds, ultra low inertness, greater unwavering quality, gigantic organization limit, expanded accessibility, and a more uniform client experience to additional clients. Better execution and further developed effectiveness engage new client encounters and associates new enterprises[4]
- **6G Technology:** The examination local area is right now talking about the bearing toward the 6th era (6G) and vision of 6G versatile organizations under different known as B5G, 5G+, and 6G. 6G is presently the ongoing remote correspondence innovation being developed, a steady development from the underlying 1G. 6G is the innovation that will empower the 6G remote correspondence framework to turn into a reality[4]. Remote ages are delivered roughly 10 years separated. Accepting that this pattern proceeds, 6G is supposed to enter our lives around 2030. The overall attributes of all ages are examined to see the improvement between ages since the 1G obviously.

### III. MOBILE TECHNOLOGY CONSUMPTION

In a survey, conducted among 100 people the result shows 60% of people use mobile phones more than 4 hours a day. In 2022 97% of people use their mobile phones more than 8 hours a day[6]. A survey detected that during night time the use of internet is highly surplus. Without mobile phone a single day is not possible for us in this current scenario. So it is necessary to find the reason behind the usage of mobile phone this much important. Social media has coined the term called social interaction. There is a lot of social medias which consumes our time.

## 1. **Mobile Technology Trends :** The expanded reception of cell phones has prompted the noteworthy development of the portable application industry[15].

Presently, there are around 5.31 billion one of a kind portable clients around the world, as indicated by GSMA Insight. In 2021, clients downloaded 230 billion applications to their cell phones, which is a 63% expansion starting around **Mobile Technology Trends : 2016**, as per Statista.

The income of Android and iOS portable applications came to \$133 billion out of 2021, as per BusinessofApps.

## 2. **Here Top 5 Mobile Technologies are Illustrated Below.**

- **Artificial Intelligence:** The clearest illustration of computer based intelligence on PDAs is in the voice colleague. Regardless of what family your cell phone is from, assuming you have an associate like Siri or Google Collaborator, there is Man-made reasoning[9]. Voice acknowledgment and its amalgamation are the most clear instances of this innovation.
- **Augmented Reality and Virtual Reality:** Another stage comes consistently, the cell phone basic client brilliant time has elapsed and presently clears a path for different mediums where the client can be more drawn in and the encounters more vivid. AR is being utilized in a ton of spaces as of now, for example in the Online business area where customers are more disposed to buy an item after they've examined it with AR innovations or social applications where other than channels, the clients can likewise add AR objects in their streams[14].

In VR universes, the clients typically have extra gadgets (joysticks, and so on) for communicating with virtual items. Since we are discussing versatile applications, VR isn't that famous and utilized because of the idea of the gadget.

- **Mobile IoT Apps:** The Web of Things has become standard in numerous areas, from medical services and agribusiness to assembling and transportation, which has prompted the expanded improvement of IoT applications. So, IoT applications overcome any barrier between associated cell phones and individuals[11].

Applications are the instruments for distant administration of associated gadgets, permitting clients to:

- screen readings of cell phones and sensors
- investigate information, construct diagrams and create reports
- oversee gadgets (design, open/close, turn on/off, trigger notices, from there, the sky is the limit).
- **Mobile Payments:** Notwithstanding various financial applications, the most generally utilized installment applications incorporate Apple Pay, Google Pay, PayPal, AliPay, WeChatPay and Zelle. These applications engage clients to perform monetary

exchanges quicker, more straightforward and from anyplace, adding to the blast in portable business[10]. In 2023, the pattern of creating Web based business applications for portable installments will proceed.

- **Cloud Based Mobile Applications :** Cloud innovation has developed such a great amount throughout recent years. Distributed storage is developing to become modest as specialist co-ops put resources into more productive cloud framework. Cloud innovation is the foundation of portable application advancement in 2023.

Numerous things we do on applications today influence cloud innovation, such as booking a taxi or requesting food[12]. Cloud has made web facilitating modest, more burden proficient and open. This has provoked the speedy reception of the portable innovation pattern.

#### IV. SOCIAL INTERACTIONS BY SOCIAL MEDIA

Web-based entertainment began in the mid 2000s. The principal web-based entertainment website to arrive at 1,000,000 month to month dynamic clients was MySpace - it accomplished this achievement around 2004. This is seemingly the start of virtual entertainment as far as we might be concerned. In the intelligent diagram we plot month to month dynamic clients, by stage, starting around 2004.

1. **Social Interactions Using Mobile Phones:** Slowly, mobile phone has become one important part of the human life and has eventually replaced the face-to-face communication by introducing social media [15]. The reception of the cell phone by youngsters has been a worldwide peculiarity lately. The use of such advancements has expanded emphatically over the course of the last ten years and the majority of the majority are enjoyed its use[1],[2],[13].

Based on a study [14] it is observed that face to face communication with friends and family members had been decreased badly as a result of the technology utilization. People are enjoying their own lonely time occupying themselves with lifeless devices.

2. **Origin of Social Media:** In 1987, the immediate forerunner to the present web appeared when the Public Science Establishment sent off a more hearty, cross country computerized network known as the NSFNET. After 10 years, in 1997, the principal genuine web-based entertainment stage was sent off.

In 2002, LinkedIn was established as a systems administration site for vocation disapproved of experts. By 2020, it had developed to in excess of 675 million clients around the world. It stays the web-based entertainment webpage of decision for work searchers as well as HR administrators looking for qualified up-and-comers.

Two other significant introductions to online entertainment fell after an eruption of beginning achievement[12]. In 2003, Myspace sent off. By 2006, it was the most visited site on earth, prodded by clients' capacity to share new music straightforwardly on their profile pages.

## V. CONCLUSION

Social media might play an evident role in the current scenario. All the technologies have both sides; benefits and problems. As people we have to find out the best ways to use them in a right manner. It provides many facilities even entrepreneurship through its broad community of people. Its evolution is uncontrollable day by day. We can enjoy our life using the mobile communications and social media in an ethical manner.

## REFERENCES

- [1] Banafaa, M., Shayea, I., Din, J., Azmi, M. H., Alashbi, A., Daradkeh, Y. I., & Alhammadi, A. (2023). 6G mobile communication technology: Requirements, targets, applications, challenges, advantages, and opportunities. *Alexandria Engineering Journal*, 64, 245-274.
- [2] Abascal, J., & Civit Balcells, A. (2023, March). Mobile communication for older people: new opportunities for autonomous life. In *Workshop on Universal Accessibility of Ubiquitous Computing: Providing for the Elderly (2000)*.
- [3] Elliott, J., Hounghonon, G. V., Ivaldi, M., & Scott, P. (2023). Market structure, investment and technical efficiencies in mobile telecommunications.
- [4] Alraih, S., Shayea, I., Behjati, M., Nordin, R., Abdullah, N. F., Abu-Samah, A., & Nandi, D. (2022). Revolution or evolution? Technical requirements and considerations towards 6G mobile communications. *Sensors*, 22(3), 762.
- [5] Azemi, Y., Ozuem, W., Wiid, R., & Hobson, A. (2022). Luxury fashion brand customers' perceptions of mobile marketing: Evidence of multiple communications and marketing channels. *Journal of Retailing and Consumer Services*, 66, 102944.
- [6] Haibeh, L. A., Yagoub, M. C., & Jarray, A. (2022). A survey on mobile edge computing infrastructure: Design, resource management, and optimization approaches. *IEEE Access*, 10, 27591-27610.
- [7] Gopi, B., Logeshwaran, J., & Kiruthiga, T. (2022). An Innovation in the Development of a Mobile Radio Model for a Dual-Band Transceiver in Wireless Cellular Communication. *BOHR International Journal of Computational Intelligence and Communication Network*, 1(1), 20-25.
- [8] Habibi, M. A., Nasimi, M., Han, B., & Schotten, H. D. (2019). A comprehensive survey of RAN architectures toward 5G mobile communication system. *Ieee Access*, 7, 70371-70421.
- [9] Zhou, Y., Tian, L., Liu, L., & Qi, Y. (2019). Fog computing enabled future mobile communication networks: A convergence of communication and computing. *IEEE Communications Magazine*, 57(5), 20-27.
- [10] Wong, L. W., Tan, G. W. H., Hew, J. J., Ooi, K. B., & Leong, L. Y. (2022). Mobile social media marketing: a new marketing channel among digital natives in higher education?. *Journal of Marketing for Higher Education*, 32(1), 113-137.
- [11] Yang, K. C., Kang, Y., & Wang, R. P. (2022). Integrating social and mobile media in environmental marketing communications in China: Opportunities and challenges. *Research Anthology on Social Media Advertising and Building Consumer Relationships*, 1246-1264.
- [12] Tsao, S. F., Chen, H., Tisseverasinghe, T., Yang, Y., Li, L., & Butt, Z. A. (2021). What social media told us in the time of COVID-19: a scoping review. *The Lancet Digital Health*, 3(3), e175-e194.
- [13] Olanrewaju, A. S. T., Hossain, M. A., Whiteside, N., & Mercieca, P. (2020). Social media and entrepreneurship research: A literature review. *International Journal of Information Management*, 50, 90-110.
- [14] Ortiz-Ospina, E., & Roser, M. (2023). The rise of social media. *Our world in data*.
- [15] Auxier, B., & Anderson, M. (2021). Social media use in 2021. *Pew Research Center*, 1, 1-4.