

SEED QUANTIFYING AND PACKAGING UNIT FOR SMALL-SCALE ENTERPRISES

Abstract

Before the green revolution, farmers are lied on saving seeds from the previous crop cycle. Today, advanced seeds from companies are dominating farmers' fields. This shift has spurred innovation in the agriculture sector, driven by the increasing demand for packaged seeds, necessitating automation for efficient production. Manually weighing or counting seeds and packaging them are no longer viable as bulk production is required. Also, Packaging seeds by weight leads to revenue loss as seed companies often supply excessive amounts to ensure the promised quantity. Additionally, farmers, uncertain about the seed quantity in each bag, tend to order extra. Therefore, seed companies recognize seed counting as a crucial cost-saving and demand-meeting tool, assuring both parties involved. The seed industry has made significant progress, and many seed-counting machines have been introduced in India. They are, however, very expensive and, at times, lack efficiency.

The proposed work introduces an affordable and reliable seed counting and packaging machine. The machine incorporates a vibrating platform where the user pours the seeds to be quantified. The hardware is designed such that, one seed at a time is dropped. A proximity sensor is used to record the count and a load cell to measure the seeds by weight. This product aims to be a reliable and rapid seed counting and packaging machine at an affordable price, allowing small/medium scale industries to eliminate out dated methods and avoid costly investments in expensive machinery, thus stream lining seed production processes.

Keywords: crops, seeds, cultivation, agriculture, machinery

Authors

Dr. R. Manjunatha

Department of ECE
P.E.S College of Engineering
Mandya, India .

Shashank B. M

Department of ECE
P.E.S College of Engineering
Mandya, India.

Ruthuparna. K

Department of ECE
P.E.S College of Engineering
Mandya, India.

Suhruth. M. V. Jamadagni

Department of ECE
P.E.S College of Engineering
Mandya, India.

Vaishnavi. M

Department of ECE
P.E.S College of Engineering
Mandya, India.

I. INTRODUCTION

The history of agricultural progress since the early days of man has been the history of seeds for new crops and crop varieties brought under cultivation. In the early days, it was achieved through the cultivation of indigenous plants/ In recent times, through the well-known techniques of selection, hybridization, mutation, polyploidization, and plant biotechnology, scientists have made available many new and better varieties. However, to the farmer, all this scientific research would be of little value unless they got genetically pure seeds, had a high germination percentage and vigor, were in sound health, etc. Seeds are the basic and most critical input for sustainable agriculture. It is estimated that the direct contribution of quality seed alone to the total production is about 15–20%. In 2018, the Indian seeds market reached a value of US\$ 4.1 Billion, registering a CAGR of 15.7% during 2011–2018[10]. The seed industry in India reached US\$ 6.3 Billion in 2022. Looking forward, the market is to reach US\$12.7Billion by 2028, exhibiting a growth rate(CAGR)of 12.43% during 2023-2028.

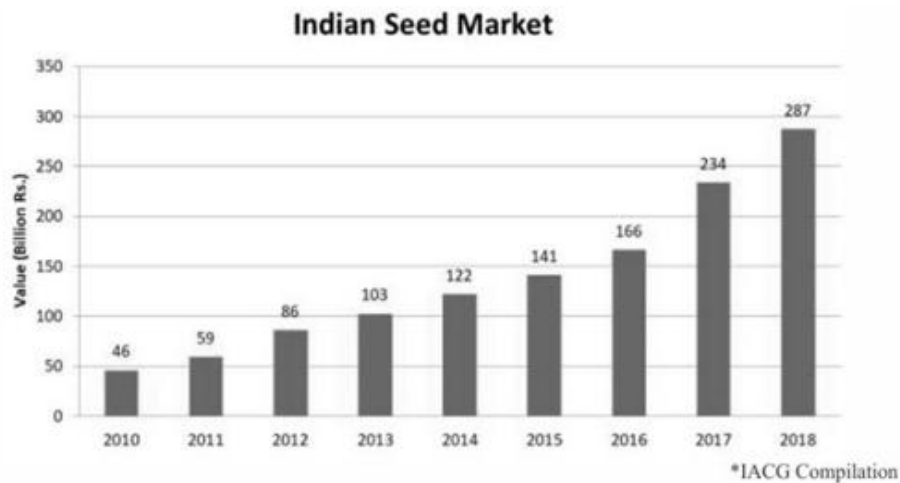

Figure 1: Indian Seed Market Trend. Image from Report on Seed Industry Scenario, World Seed Trade and Technology Congress 2019

Traditionally, the seed packaging industry packed seeds by weight using weighing scales. To assure the correct quantity of seeds, seed distributors added a safety margin to the packed weight. Also, farmers have no idea how many seeds they will receive in each bag, so they tend to order additional bags to be certain they get the required amount. This safety margin results in a loss of revenue. Only with counting-based systems can both the seed company and the farmer know exactly how many seeds each bag contains. Consequently, the seed company can reduce the automatic overfill and the farmer can purchase the precise number of seeds needed, and the outcome is a substantial financial saving for both sides. The seed counter is a uniquely appropriate solution for items that are sold by units as opposed to weight. The machines typically provide total counts of seeds or batch sizes for packaging.

Amidst India's new-age agricultural revolution, a shift towards packed seeds is evident as farmers value high-quality, treated seeds over saving seeds from the previous crop cycle. The main reasons are the need for specialized equipment, storage space, and the

benefits of treated seeds. Hybrids are made by crossing two highly inbred parent. Every seed that is planted has the same genetics. Farmers know that they will get a very consistent crop in each field when they plant hybrid seeds. Seed companies of all sizes that invest heavily in R&D recognize the significance of seed counting to optimize cost savings during the packing stage.

II. LITERATURE SURVEY

India is an agrarian economy that ranks second globally in food and agricultural production. Agriculture accounted for 17.8% of GDP and employed 59% of the country's workforce in 2020 and continues to clock a stable growth. The farmers of the nation are in need of seeds for ploughing and cultivation and these days advanced seeds developed by seed companies dominate the farmers' fields. With these developments, the face of seed production has changed and new challenges have paved the road for innovation in this sector. The increase in demand for hybrid, packaged seeds has played a key role in companies having to adopt automation to keep up.

- **Automatic Seed Counting System [1]:** In this paper, the complete seed counting model is explained. The focus of the project is on building a system which could tackle the problem of inaccurate seed measurement and counter the accurate number of seeds. For this purpose, an IR sensor-based counting system would operate the belt conveyor after a certain number of grains/seeds fall in the box and the next box comes into the cycle. There are a lot of potential aspects that can be taken and innovated from this paper, like the seed weighing and processing device and the photo electric seed counter. This paper serves as the backbone for project ideation.
- **Study, Testing and Application of Proximity Sensors for Experimental Training on Measurement Systems [2]:** This paper from the 2017 18th International Carpathian Control Conference, presents an experimental system that allows the study and testing of two proximity sensors (inductive and capacitive) and their utility through the understanding of operation, selection and explanation of information from datasheets. This paper presents an efficient method for experimental training in the field of proximity sensors and has been used as a reference for designing the counting mechanism for the project.
- **Research of New Type Cell Wheel Feed Precision Seed-Metering Device[3]:** A paper Published at the 2011 International Conference on New Technology of Agricultural speaks about a new wheel cell precision feed that consists mainly of a feeding cell, guide plate, cell wheel, brush wheel, friction plate, clamp and transmission parts. Cell wheel feed is a kind of typical mechanical precision seed-metering device featuring a simple structure, reliable performance and low costs. The paper is insightful and the system discussed there, for seeding is used as the basis for our feeder module.
- **Electro-Magnetic Actuated Vibrating Platform [4]:** A paper Published in the 2013 IEEE 19th International Symposium for Design and Technology in Electronic Packaging, presents a model of a vibrating platform based on an electromagnetic actuator. The vibrating platform consists of a rigid plate articulated on one side of the

frame, an electromagnetic actuator consisting of a moving core and a fixed coil, an electronic control system and a vibration transducer that produces the plate oscillations in a vertical plane. This design with modifications can be suitable for de-clustering and forcing the seeds down through the iris in the proposed model

- **A photoelectric seed counter [5]:** This paper presents a system for automated counting of seeds and similar small particles. The system described in this paper uses a photosensitive detector and a vacuum pickup to count individual seeds and gives a direct digital readout.
- **Study on the principle of an air-blowing type seed metering device [6]:** Published in the Chinese Society for agricultural machinery journal, the paper describes a seed metering Device that counts seeds by passing seeds through an air-blowing tunnel. This type of feeder mechanism consumes more energy and is bulky but effective in letting seeds in a serial fashion thus is more accurate in its counting.
- **A Photoelectric Seed Counting Detector [7]:** The paper describes an inexpensive and simple detector with high accuracy. The operation of the described system is simple and stable, no external sensitivity control is provided for different-sized seeds. The proposed design makes use of a photoelectric seed detector which requires an external light source and fragile focussing lenses. Component collimation, a principal limitation of the speed at which can be counted is discussed. Building on the system here, the project eliminates the use of sensitive components and attempts to make the system robust by adding a mechanism to count different sizes of seeds accurately.
- **Testing of Electric Signals from Piezoelectric Sensor in Application for Counting Grains in Seeding Machines [8]:** This paper describes the experimental setup that uses a piezoelectric sensor to control the movement of grains in agricultural seed machines and also focuses on the precision sowing of seeds using two seed species. The counting system described in this paper gives a new dimension by using a piezoelectric sensor to count the number of seeds compared to the technique that uses a photoelectric sensor. This work plans to use a proximity sensor as this sensor serves as a middle ground between the two options available.

III. SEED MORPHOLOGY

Seed morphology encompasses the examination of various physical features, such as seed size, shape, texture, and colour, which play a crucial role in seed identification and classification. While seed size tends to be relatively consistent within a species, variations can occur depending on factors like seed position within a fruit or on the plant, seed maturity, and environmental influences. Additionally, dimorphic or heteromorphic seeds, as well as abnormalities caused by external factors like chemicals or diseases, contribute to size variations. For accurate seed size measurements, validated tools like calibrated rulers, vernier callipers, and eyepiece micrometres are commonly employed. Digital equipment may also be used, but manual methods are preferred when precise positioning is necessary for displaying the length, width, and thickness axes of certain seeds. Proper evaluation of seed size is essential for distinguishing and establishing baseline parameters for a given variety of seeds. Once the physical parameters of a given seed are established by replicating the process across

batches of seed, the same is used to program the apparatus.
Below are a few illustrations of seed measurement:

1. **Seed length:** The maximum seed length of a cleaned, mature seed. Measurement is usually the longest axis of the seed.



Figure 2: Measurement of Seed Length

2. **Seed width:** The maximum seed width of a seed under measurement, usually the second longest axis, perpendicular or nearly so to the length axis.



Figure 3: Measurement of Seed width

3. **Seed thickness:** The maximum seed thickness under measurement, usually the third longest axis, if needed.



Figure 4: Measurement of Seed Thickness

The above images show the measurements of Corn Seed done digital vernier calliper. The seed data was recorded as per the seed measurement protocol provided by the international seed morphology association:

(a) Length and Width axes

(b) Thickness axes



Figure 5: Seed Axes

- Test Seed Variety 1: DILL Seeds



Figure 6: Dill Seeds

Table I: Dill Seed

Common Name	Dill Leaf Seeds
Species	Anethum graveolens
Kingdom	Apiaceae
Classification	Very Small Sized Seed

Dill, an annual herb, produces small oval-shaped, light- brown seeds with aromatic flavour, sold solely by weight due to their size. The system is customized to accommodate this very small-sized seed variety (dimensions less than 10mm), bypassing user input stages for counting. The proximity sensor remains idle and the loadcell is active.

- Test Seed Variety 2: Red Maize Seeds

Common Name	Red Maze
Taxon	Zea mays
Family	Poaceae

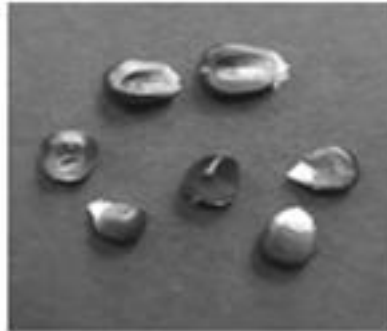

Figure: 7 & Table II: Red Maize

seed no	length(mm)	width(mm)	thickness(mm)
1	10.13	8.62	6.03
2	10.21	8.79	4.25
3	9.26	8.5	3.92
4	10.05	8.77	4.08
5	11.14	7.3	3.92
6	9.44	8.31	5.64
7	9.64	8.46	3.98
8	10.36	8.25	3.6
9	10.08	10.24	5.46
10	11.96	8.51	4.07
11	9.6	8.13	4.54
12	11.44	8.05	4.26
13	11.57	8.36	4.16
14	9.79	9.41	3.91
15	10.76	9.88	3.15
16	10.32	9.13	2.98
17	9.26	8.1	3.43
18	11.95	8.7	4.7
19	10.5	8.51	4.51
20	9.25	6.84	4.45
21	10.57	9.57	4.81
22	10.39	9.2	3.92
23	10.21	8.66	4.01
24	9.57	10.12	4.94
25	10.52	8.57	4.04
26	11.09	7.92	3.63
27	8.96	8.37	5.09
28	10.01	7.93	3.74
29	12.72	8.6	4.88

30	10.66	8.05	4.18
31	9.58	7.9	3.47
32	10.8	7.93	3.54
33	10.19	8.06	4.25
34	9.13	8.06	4.36
35	9.72	8.5	5.12
36	9.11	8.04	4.26
37	9.66	8.47	3.88
38	11.02	10.08	5.1
39	9.01	8.95	3.37
40	9.92	7.51	3.62
41	9.66	7.75	4.26
42	9.61	7.35	5.79
43	9.18	7.34	3.5
44	9.19	8.41	4.7
45	9.79	8.28	5.55
46	10.03	8.5	3.72
47	9.78	9.42	3.92
48	10.47	7.93	6.05
49	10.3	7.71	6
50	9.36	8.11	4.2

Table III: Measurement of Maze seed quantification by count**Table IV:** Measurement of Red Maize seed weight to enable quantification by weight

Trial	Net. Weight	No. of Seeds
1	10 grams	41
2	10 grams	40
3	10 grams	39

Also known as maize (*Zea mays*), red corn is one of the world's most popular cereal grains. It's the seed of a plant in the grass family, native to Central America but grown in countless varieties worldwide. Maize has become a staple food in many parts of the world, it is widely cultivated throughout the world, and a greater weight of maize is produced each year than any other grain. India produces 27 million tonnes of maize every year. Corn is typically yellow but comes in a variety of other colours, such as red, orange, purple, blue, white, and black. Upon measurement of seed dimensions and weight from different batches of seeds, the following insights were drawn:

Parameters	Length (mm)	Width(m)	Thickness(mm)
Minimum	8.96	6.84	2.98
Average	10.1384	10.24	4.33
Maximum	12.72	10.24	6.05
Classification		Medium Sized Seed	

Table V: Insights from Red Maize Seed Measurements

The system is programmed to open the flaps in accordance with the maximum dimensions of the seed to ensure the channelization of seeds for counting.

- Test Seed Variety 3: Red Beans



Figure 8: Bean Seeds

Common Name	Red Bean
Species	Phaseolus vulgaris
Kingdom	Legumes

Table VI: Bean Seeds

Red kidney beans are one of the many varieties of common beans. Red beans are kidney-shaped and have a deep glossy red colour. The maximum dimension of the seeds is determined by measuring seed dimensions and weight from different batches of seeds, and the flaps are opened accordingly to facilitate quantification.

Seed no.	Length(mm)	Width(mm)	Thickness(mm)
1	13.5	6.72	5.41
2	13.08	6.8	5.26
3	13.97	6.41	5.83
4	14.03	6.68	5.21
5	12.47	6.23	5.52
6	13.78	7.35	5.69
7	13.22	6.82	5.89
8	12.84	6.31	4.8
9	15.34	7.23	6.02
10	14.19	7.11	6.02
11	11.9	5.38	5.25
12	13.53	7.25	5.69
13	14.05	6.62	5.65
14	14.2	7.23	5.69
15	15.42	7.42	6.15
16	12.36	6.63	5.36
17	14.67	7.36	5.36
18	12.96	6.78	5.88
19	12.76	6.48	4.67
20	13.07	6.93	5.27
21	12.54	6.14	5.1
22	12.16	6.66	5.64
23	12.71	6.33	5.65
24	14.84	6.54	5.99
25	13.74	6.94	5.82
26	12.3	6.66	5.36
27	13.57	6.74	5.06
28	12.36	5.48	4.69
29	15.52	5.53	5.74
30	13.84	7.06	5.32
31	13.24	6.62	5.05
32	12.45	6.19	5.54
33	12.26	6.63	5.6
34	13.05	6.22	4.81
35	12.48	5.77	5.01
36	14.07	6.63	5.29
37	11.62	6.89	5.42
38	11.43	6.37	4.97

39	12.31	4.96	4.93
40	12.09	6.23	5.06
41	11.64	5.77	4.76
42	12.87	6.52	4.93
43	13.51	6.16	5.16
44	13.41	5.84	5.18
45	10.76	6.01	4.79
46	12.42	6.23	4.79
47	12.24	6.42	5.05
48	12.06	6.12	4.23
49	13.02	6.65	5.43
50	14.2	7.23	6.15

Table VII: Measurement of Bean seed dimensions to ensure quantification by count

Trials	Net. Weight	No. of Seeds
1	10 grams	41
2	10 grams	40
3	10 grams	39

Table VIII: Measurement of Bean seed weight to enable quantification by weight

Parameters	Length (mm)	Width(m m)	Thickness(mm)
Minimum	10.76	4.96	4.23
Average	13.121	6.5056	5.3312
Maximum	15.52	7.42	6.15
Classification		Medium Sized Seed	

Table IX: Insights from Bean Seed Measurements

- Test Seed Variety 4: OKRA



Figure 9: Okra Seeds

Common Name	Lady's finger
Taxon	Abelmoschus esculentus
Family	Mallows

Table X: Okra Seeds

Okra (*Abelmoschus esculentus*) seeds play a crucial role in the propagation of the popular okra plant. These seeds are characterized by their small, round to oval shape and distinctive dark brown to black colouration.

The unique shape of the okra seeds presents a limitation in measurement, as it allows for the assessment of only their diameter. From observations and data presented in the table below, it is evident that the diameter of the okra seeds is consistently less than 10mm. This limitation in measuring only the diameter showcases the specific attributes of the okra seeds, highlighting their classification as small-sized seeds.

Seed no.	Diameter(mm)	Seed no.	Diameter(mm)
1	5.5	25	5.8
2	5.15	26	4.92
3	5.2	27	5.62
4	5.72	28	4.88
5	5.4	29	4.5
6	4.46	30	5.58
7	4.63	31	5.25
8	4.96	32	5.34
9	5.57	33	5.75
10	4.42	34	5.97
11	4.54	35	5.63
12	5.03	36	4.93
13	5.14	37	5.38
14	4.67	38	5.44
15	5.1	39	5.39
16	5.41	40	5.87
17	5.76	41	5.24
18	5.1	42	5.5
19	4.56	43	5.65
20	5.24	44	5.34
21	5.85	45	4.76
22	6.21	46	5.57
23	5.9	47	5.42
24	5.56	48	5.29
25	5.8	49	5.77
50	5.6	50	5.6

Table XI: Measurement of Okra seed dimensions to test quantification by count

Trials	Net. Weight	No. of Seeds
1	10 grams	159

2	10 grams	153
3	10 grams	147

Table XII: Measurement of Okra seed weight to enable quantification by weight

Parameters	Diameter (mm)
Minimum	4.42
Average	5.3
Maximum	6.21
Classification	Small Seed - weight only

Table XIII: Insights from Okra seed measurement

Owing to the seed dimension and limitation of existing hardware, the seed is classified as a small-sized seed and quantification of this variety is possible only by weight.

IV. DESIGN

- Vibrating Platform and Feeder:** The feeder design is such that seeds can be easily loaded atop the feeder. A vibrating platform made of 0.5mm industrial grade Aluminium sheet metal is supported by a platform made of white PVC sun board and four Heavy Duty Constant Rate Helical-30 Coil springs of Compression type with a height of 11cm, an outer diameter of 1.8cm, an inner diameter of 1.4cm, and a pitch of 4mm supports the feeder platform. A 12V DC Vibrating motor is housed in a casing beneath the platform and provides vibrations to the platform. The spring legs are used to move in proportion to the vibrations produced by the motor, allowing the seeds on the feeder to be de-clustered and facilitating their movement towards the counting and weighing units. intensity of vibrations can be easily controlled by varying the motor speed. The vibration control mechanism allows the system to dynamically adapt to a seed variety (size) and thus achieving the lowest possible error while counting.

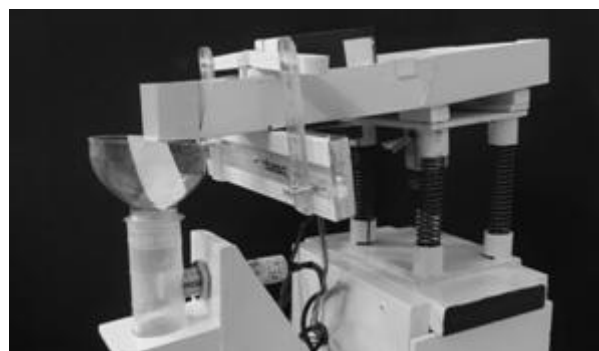

Figure 10: Vibrating Platform and feeder

- Channelising Flaps:** It is critical for any given counting system that targets follow one

another and do not overwhelm the sensor. In order to achieve the same, the Seed quantifying unit for small-scale enterprises makes use of soft-plastic channelizing flaps as shown in the figure. The design and implementation of these flaps serves as the basis and is of utmost importance for the functioning of the counting mechanism. The flaps are integrated into the feeder platform discussed above and their lateral movement is controlled by rack-pinion arrangement and a stepper motor. The racks are arranged in a way such that the pinion when rotated forces the racks to move in opposite directions. The racks are tied to the flaps with the help of hard plastic and white PVC Sun-board sticks as shown in the picture above. This mechanism allows for smooth opening and closing actions of the flaps. The rack and pinion arrangement provides precise and symmetrical movement of the flaps with respect to the steps of the stepper-motor shaft and thus provides the ability to control the opening of the flaps in accordance with the dimensions of the selected seed varieties. These flaps complement the vibration mechanism and help ensure the passage of seeds in a single file. There by enabling the channelization o fseeds.

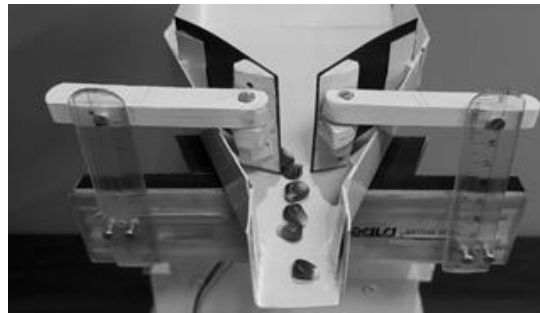

Figure 11: Chennalising flaps as seen on the prototype

- 3. Counting Module:** The counting module comprises an N-P-N, Normally closed Dielectric Capacitive Proximity Sensor. The Dielectric Capacitive Proximity Sensors can detect any object whose dielectric is more than the air and thus is an ideal sensor for this counting application. Keeping in mind the maximum sensing distance, the proximity sensor is placed inside a polycarbonate case. This ensures that the target (Seeds) passes by the sensing plates at an optimal distance and speed, the probability of a miss can be greatly re-



Figure 12: Counting Module as seen on the prototype

- 4. Graphical User Interface:** The graphical user interface consisting of a keypad and an LCD display, allows the user to quantify seeds based on their needs. By concealing the inner workings, user controls have been simplified. Nonetheless, the user has complete command of the system. It also shows the live count and weight while allowing for user interaction
- 5. Weighing Module:** The weighing module consists of a strain-gauge type load cell and adds the ability to quantify by weight to the system. The seeds passing by the capacitive proximity sensor–counting module reach the collecting platform placed atop the loadcell which weighs the seed weight in the range (of 1g to 40 kg). The weighing module with the counting module acts as a well- rounded quantifying system.



Figure 13: Weighing Module as seen on the prototype

V. WORKING METHODOLOGY

A Vibrating Platform (Feeder mechanism), Movable Flaps, a Counting and Weighing Unit, and a Graphical User Interface make up the Seed Quantifying Module.

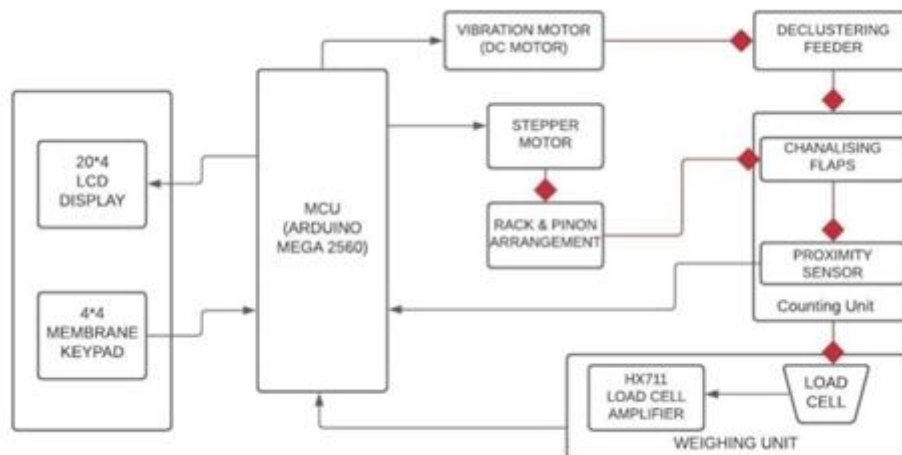

Figure 14: Block Diagram

A 20x4 LCD and a 4x4 Keypad constitute the Graphical User Interface, which allows the user to interact with the system. The LCD can display a variety of outputs, including seed selection, live count/weight, and results. The user can select the seed variety and enter

numeric data for quantification using the 4x4 Keypad. The rack and pinion arrangement is regulated with the help of the stepper motor, the flaps open based on the seed variety provided by the user, and the opening is automatically controlled based on the type of seed. After the flaps have been set to the seed variety. The microcontroller transmits an instruction to the DC motor to start vibrating, enabling, seed de-clustering and channelization. To enable/update the count, the de-clustered seeds are allowed to fall freely down a channelized path, with each seed passing through a proximity sensor wrapped in a poly-carbonate casing. The channelized path ensures that the target remains within the sensor's sensing range. The weighing platform, which is placed above the load cell, is accessible via the channelized path. The weight being placed on the collecting platform is constantly measured by the calibrated load cell.

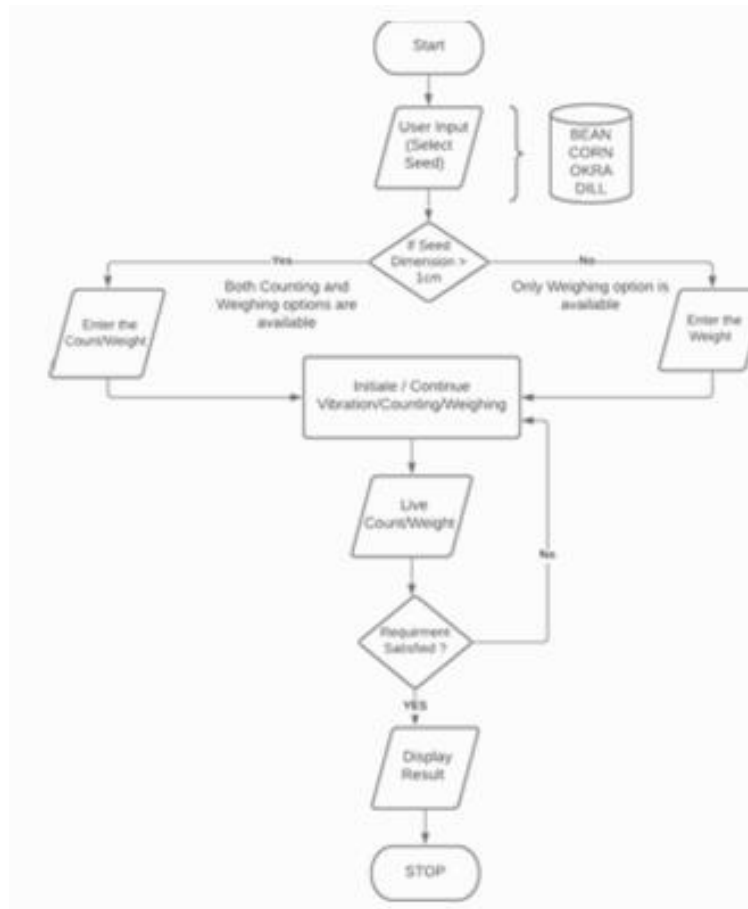

Figure 15: Flow Chart depicting the algorithm for seed quantification

The User Interface provides a visual representation of the underlying processes and improves accessibility for the user. The system starts by displaying a welcome screen that contains information about the device. It then enters the menu section where the user may choose to begin the quantification process.

The process begins with the user selecting the variety of seeds to be quantified. The system provides an inbuilt repository of the various varieties to choose from, while also permitting the user to add their own configurations for new varieties. All varieties that span a dimension of less than 10 mm are automatically selected to be quantified by weight, as they lack the resolution to be counted by the system. However, the user is

provided with the option to select either the count or weight option for quantification when the variety spans a dimension greater than or equal to 10 mm.

In the case of the weighing mode, the flaps are opened to the maximum setting and the seeds are allowed to flow onto the weighting plate with the aid of the vibrating platform. The load cell provides a continuous live update of the weight in the display. Once the pre-set weight is reached, the system awaits the user's consent to continue. After the user unloads the seeds and places the weighing plate back on the load cell, the system resumes its operation by beginning another cycle of weighing. After all, cycles are completed, the system displays the final result of how many seeds were weighed in total and how many packets were created.

In the case of the counting mode, the flaps are opened to a selected value defined by the variety of the seed. The seeds are made to flow in a single file through the flaps and with the aid of the vibrating platform. As seeds pass in the vicinity of the proximity sensor, it provides a live count in the display. Once the pre-set count is reached, the system awaits the user's consent to continue. After the user unloads the seeds and places the weighting plate back on the load cell, the system resumes its operation by beginning another cycle of counting. After all, cycles are completed, the system displays the final result of how many seeds were counted in total and how many packets were created.

After displaying the result, the user is redirected to the menu where they may further choose to quantify another variety of seeds. The user is also provided with the option to turn off the system when they have completed their operation. Alternatively, leaving the system in standby mode for more than 10 minutes, also automatically powers it off.

VI. RESULTS

TABLE XIV: Tests Results

SEED VARIETY	TRIALS	COUNT		WEIGHT (g)	
		Actual Count	Achieved Count	Actual Weight	Achieved Weight
BEANS	1	30	28	9.0	9.1
	2	30	27	8.6	8.6
	3	30	30	9.6	9.5
	4	30	27	8.7	8.9
	5	30	28	9.0	8.9
RED MAIZE	1	30	21	6.9	7.0
	2	30	25	6.4	6.5
	3	30	22	5.6	5.6
	4	30	24	6.1	6.0
	5	30	22	5.6	5.3
OKRA	1	NA	NA	20.0	19.9
	2	NA	NA	20.0	20.0
	3	NA	NA	20.0	19.8
	4	NA	NA	20.0	19.8
	5	NA	NA	20.0	19.9
DILL	1	NA	NA	20.0	19.5
	2	NA	NA	20.0	19.4
	3	NA	NA	20.0	19.4
	4	NA	NA	20.0	19.3
	5	NA	NA	20.0	19.3

With respect to the below testing data, the following results can be derived:

1. **Bean Seed Counting Efficiency – 93.3%, Bean Seed Weighing Efficiency – 99.7%**
2. **Red Maize Counting Efficiency – 76%, Red Maize Weighing Efficiency – 99.3%**
3. **Okra Weighing Efficiency – 96.9%**
4. **Dill Weighing Efficiency – 99.3%**

It can be concluded from the above performance metrics that the weighing module performs satisfactorily for all varieties. The counting module on the other hand drops in efficiency as the dimensions of the seed reduce. As the dimensions drop below 10 mm, it no longer serves as a reliable metric for the purpose of quantification, and therefore system resolves to quantify by weight only.

VII. CONCLUSION

The goal of this project is to develop a low-cost prototype of a seed quantifying machine for small-scale seed industries in the Indian agricultural market that currently lack low-cost machines to streamline production and packing. The prototype discussed here can weigh and count seeds at the same time or as required by the user. During the development of the system discussed in the previous chapters, various approaches for the different tasks were examined. Finally, the desired modules were designed, manufactured, and tested to produce satisfactory results. This work demonstrates how a capacitive proximity sensor, a load cell, a stepper motor, a DC motor, and other inexpensive materials such as a rack-pinion set and PVC sun board when mechanically arranged precisely, can function as a quantifying machine. The system responded positively to operations including selected seed varieties that are popular in the market. It thereby exhibited its capability and resilience to compete with existing products. A further market deployment study will herald in uncovering its performance as well as introduce new avenues of growth for the product, as it possesses the potential to branch into other quantifying domains such as the mechanical small parts industry, pharmaceutical industry, etc.

With the advent of the development of this product, small businesses can now benefit massively by adopting a low investment solution with high returns in performance, allowing them to scale up production and meet the increasing demand, all the while growing less dependent on manual labour.

VIII. ADVANTAGES AND SHORTCOMINGS

1. Advantages

- Counting and weighing can be achieved together using the machine.
- Flexible, can be scaled to different seed varieties.
- Minimal human intervention since the complete quantifying line is automatic
- Saving Labour Costs
- Monetary benefits to both the parties (Seed companies and Customers)

2. Shortcomings

- As the seeds fall freely past the sensor, small seeds might be missed at times.
- The user needs to manually measure the dimensions of a new (seed) variety using a calliper before adding it to the database system.
- The user needs to overlook the packaging process automatically.

IX. OTHER APPLICATIONS

1. To count different varieties of tablets and capsules in pharmaceutical industries
2. To count mechanical components like screws, rivets, nuts, nails and bolts in production houses
3. To count or weigh different categories of field crops like, cereals, millets, pulses, oilseeds, fibre, fodder and green manure crops

X. FUTURE SCOPE

1. Application-specific refinement can be made to achieve better results
2. Addition of a packaging unit, by replacing the (seed) collection palette over the weighing module with a funnel or conveyor belt system
3. Along with counting and weighing modules, an additional (seed) segregator can be added to further automate the process and for quality
4. An inventory management system over the cloud can be integrated to work with the system control purposes

REFERENCES

- [1] Jangali Satish G; Girish Karikatti; Anjali Kathani; Sanjay Gunjetti, "Automatic Seed Counting System", International Journal of Engineering & Technology (IJERT), —Vol. 4, Issue 05 — May 2015, ISSN: 2278-018.
- [2] Dorina Purcaru; Ion Mircea Gordan, "Study, Testing and Applications of Proximity Sensors for Experimental Training on Measure Systems", 978-1-5090-4862 ©2017IEEE.
- [3] Wang Yecheng; Qiu Lichun, "Research of New Type Cell Wheel Feed Precision Seed Metering Device", 978-1-4244-9577-1/11/\$26.00 ©2011 IEEE.
- [4] Alexandru Vasile; Elena-Lauran Trifan, "Electro-Magnetic Actuated Vibrating Platform", 19th International Symposium for Design and Technology in Electronic Packaging (SIITME), 978-1-4799-1555-2/13/\$31.00 ©2013 IEEE.
- [5] W.S Reid; D.J Buckley; W. Mason, "A Photoelectric Seed Counting Detector", J.agric. Engineering Res. (1976)21, 213-215.
- [6] Ma Chenglin, "Study on the Principle of an Air-Blowing Type Seed- Metering Device[J], Transactions of the Chinese Society for Agricultural Machinery, 2019, 12(4), P1-12. (Ch).
- [7] H D Either; M Brown, "A Photoelectric Seed Counter", Agronomy Journal, Vol.65, July-August 1973.
- [8] Jan Szymenderski; Lukasz Gierz; Dawid Wojcieszak; Krzysztof Koszela, "Testing of Electric Signals from Piezoelectric Sensors in Application for Counting Grains in Seeding Machine".

