

BASICS OF OPTICS AND OPTICAL FIBER COMMUNICATION

Authors

Dr. Arif Tamboli

tambolipoona@gmail.com

I. OPTICS AND FIBER OPTIC COMMUNICATION

- 1. Overview Of Optics And Optical Fiber Communication:** Topic Covered: History of fiber optic systems, block diagram, Fiber material, fiber cables and fiber fabrication, Propagation of light in optical fiber, acceptance angle, numerical aperture, Types and specification of optical fiber, Advantages of optical fiber communication, applications, fiber joints, fiber connectors, splicer.

Fiber Optic Communication plays very important role in between the communication of various nations starting from Japan to Asia to middle east to Europe to America.

As shown below the Optical Fiber cables are laid down under the sea and these cables are called as Submarine Cables. The name Submarine Cable comes from Submarine which is under water.

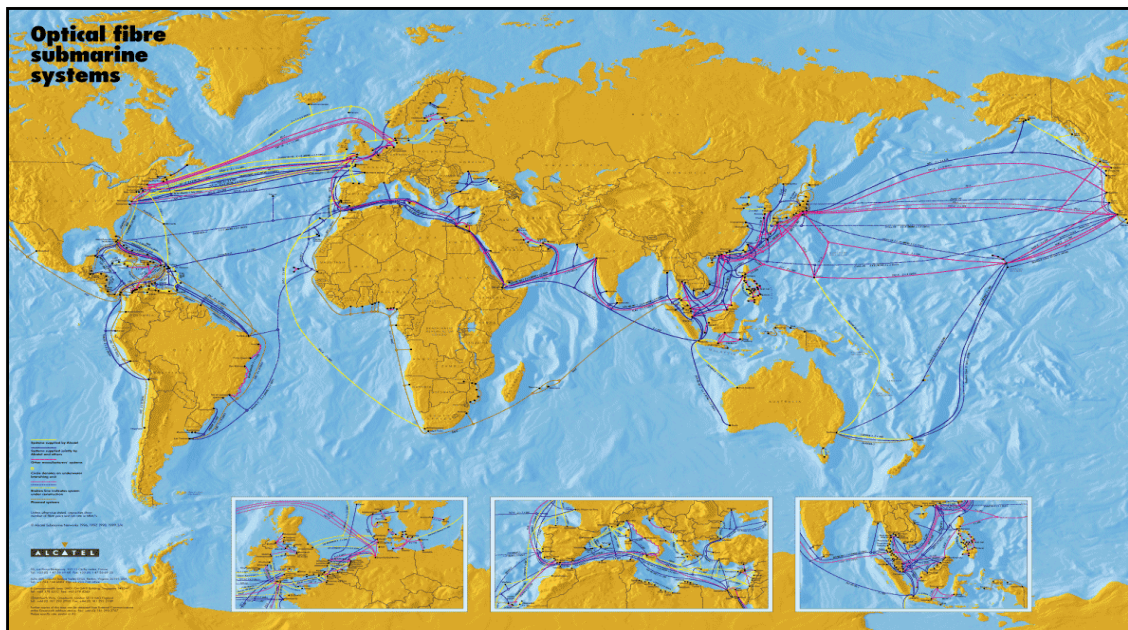

As the name suggest Fiber Optic Communication the fiber is use for transmitting or carrying the Information Signal. The fiber is special type of material made from glass. In this type of communication, the information signal is in the form of light signal. In conventional

or traditional communication, the metallic cables (copper cable) are used for transmitting or carrying the Information Signal and an Information signal is in the form of an electric signal.

The information signal is always non electric signal (Audio or Video) therefore it is first converted in to electric signal and thereafter in to light signal. Therefore, in Fiber Optic Communication light sources of particular wavelength are required.

At the receiving end we require photo detector to convert the light signal in to electric signal.

An *optical fiber* is a glass or plastic fiber designed to guide light along its length. Fiber optics is the overlap of applied science and engineering concerned with the design and application of optical fibers. Optical fibers are thin cylindrical dielectric (non-conductive) waveguides used to send light energy for communication. Optical fibers consist of three parts: the core, the cladding, and the coating or buffer.

Optical fibers are widely used in fiber-optic communication, which permits transmission over longer distances and at high data rates than other forms of communications. Fibers are used instead of metal wires because signals travel along them with less loss, and they are immune to electromagnetic interference. Optical fibers are also used to form sensors, and in a variety of other applications.

Light is kept in the "core" of the optical fiber by total internal reflection. This causes the fiber to act as a wave-guide. Fibers which support many propagation paths or transverse modes are called multi-mode fibers (MMF). Fibers which support only a single mode are called single mode fibers (SMF). Multi-mode fibers generally have a large-diameter core, and are used for short-distance communication links or for applications where high power must be transmitted. Single mode fibers are used for most communication links longer than 200 meters.

Joining lengths of optical fiber is more complex than joining electrical wire or cable. The ends of the fiber must be carefully cleaved, and then spliced together either mechanically or by fusing them together with an electric arc. Special connectors are used to make removable connections.

Materials and fiber design depend on operating conditions and intended application. Optical fibers are protected from the environment by incorporating the fiber into some type of cable structure. Cable strength members and outer jackets protect the fiber. Optical cable structure and material composition depend on the conditions of operation and the intended application.

2. Let us understand the Fiber Optic Communication from Block Diagram.

Block diagram of Fiber Optic Communication System

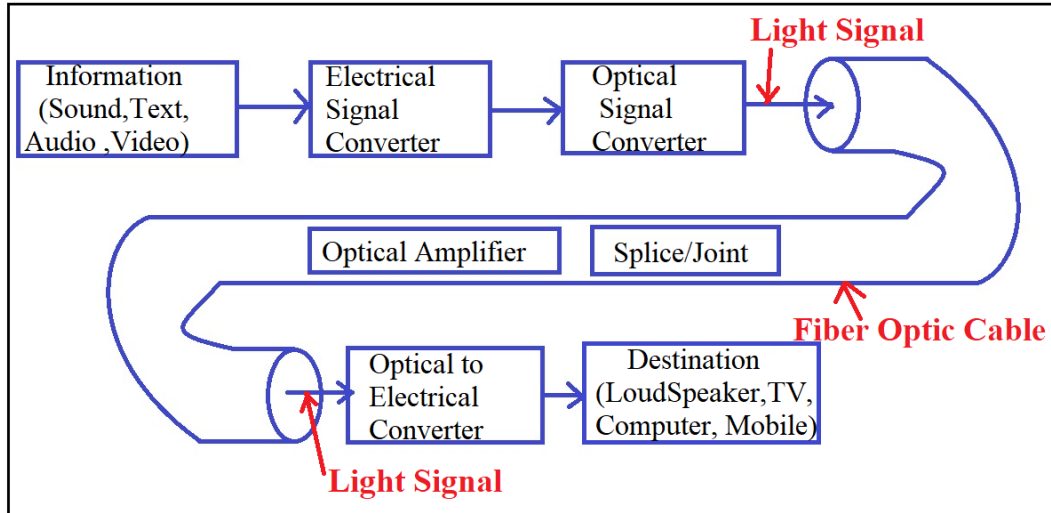

As shown above the first block is information, which consist of Signal in the form of Sound, Text and combination of Audio and Video.

In second block all these signals are converted in to an Electrical signal by using proper transducer such as Microphone, Key board of Computer or keypad of mobile phone and Video Camera along with Microphone.

Microphone converts sound signal in to an Electrical signal, Key board of Computer or keypad of mobile phone converts text in to an Electrical signal and Video Camera along with Microphone converts Video (Scene) and Audio Signal in to an Electrical signal.



In third block Electrical signal is converted in to Light (Optical) signal of proper wavelength. The light sources used are LED'S or LASER Diodes.

The light emitted from a LASER is highly monochromatic; it means that light is having only one wavelength (color). LASER light is also coherent, means light emitted is having same phase and frequency therefore this light is unidirectional and dose not gets spread in all direction like the light of ordinary bulb or LED.

In contrast, light emitted from LED or ordinary bulb is a combination of many wavelengths (colors). It is incoherent or Non-Coherent light.

In the first generation of Fiber Optic Communication the Light (Optical) sources of 600 to 700 nano-meter was used, in second generation it was 900 to 1300 nano-meter and in third generation it is 1600 to 1800 nano-meter.

Due to very short wavelength in nano-meter the frequency of carrier signal (Light) is in Tera Hertz (THz) and bandwidth of Fiber Optic Communication is very very high.

Because we know the relation between the **wavelength (λ)**, **frequency (γ or f)** and **velocity of light (c) is given by equation $c = \gamma \lambda$.**

If the frequency (γ or f) carrier signal (light) is very high in that case bandwidth increases.

Secondly the information signal is carried by light and therefore the speed of transmission if signal is very high.

The light signal is pass through the Fiber Optic Cable of different types such as

- Mono mode/Single Mode step Index FOC
- Multi mode step Index FOC
- Graded Index Multi mode FOC (It is also called as Radial Index).

Laser Diodes are used for Multi mode step Index fiber optic cable to avoid the interference of light signals because in Multi mode many rays of light signals are pass simultaneously.

LED is used for Mono mode step Index fiber optic cable because in mono mode only one ray of light is pass.

At the Output of Fiber Optic Cable (Fourth Block), light signal is converted in to an Electrical signal by using proper photo converters such as 1) Photo Diode 2) Photo Transistor or 3) PIN Diode 4) Avalanche Photo Diode 5) Light Dependent Resistor (LDR).

The Photo converters must be very sensitive to detect the light signal of particular wavelength. All Photo converters produces Photo current due to recombination of EHP.

This Electrical signal is further converted in to proper Information signal (Fifth Block) by using proper transducers such as Loud speaker which converts Electric signal in to Sound or Television which converts Video signal in to Picture etc.



II. ADVANTAGES OF OPTICAL FIBER COMMUNICATION

- Information signal gets carried very fast that is Very high data transfer rates in GBPS/MBPS
- Can carry Very large information that is Very large Band Width (BW)
- Signal is Unaffected by Electromagnetic Noise.
- Fiber Cable is Light in weight and low cost as compare to conventional metallic Copper cable.
- Tapping (Stealing) of signal is very difficult because fiber is made by glass and it gets break if you tap the cable. Therefore, it is very safe and secured.

1. Another advantages of optical fibers

- Can carry much more information and Higher carrying capacity(BW)
- Much higher data rates
- Much longer distances than co-axial cables
- Less Immune to electromagnetic noise
- Light in weight
- Unaffected by atmospheric agents
- It is Thinner
- Less signal degradation
- It consumes Low power, Flexible and Non-flammable

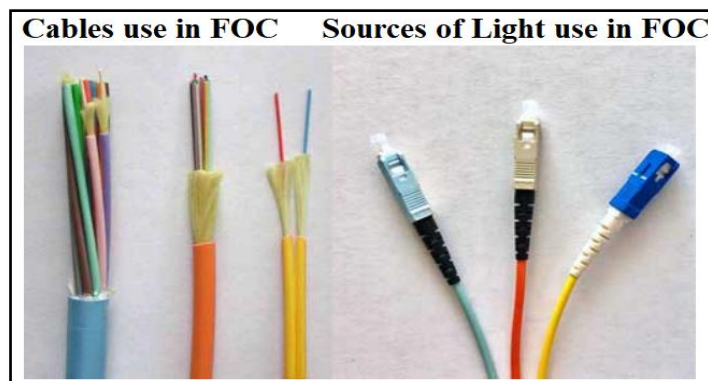

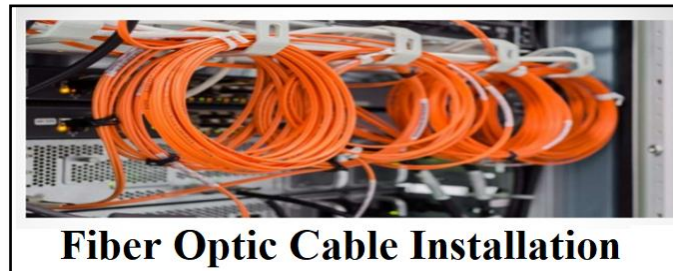

III.LOSSES IN OPTICAL FIBERS

Various Types of Losses Are

- Attenuation loss
- Dispersion loss
- Wave guide loss
- Material absorption loss
- Material Scattering loss
- Wave guide scattering loss
- Fiber bending loss
- Fiber coupling loss.

- 1. Coherent and Monochromatic Light:** Coherent means same Phase and frequency and Monochromatic means single wavelength (one color). The Coherent light is emitted by LASER Diode because it is highly directional means it propagates in only one direction. It does not get scatter in all direction. The light emitted by LASER Diode is also monochromatic because only one color means single wavelength.

The Non Coherent light is emitted by LED (Light Emitting Diode) because it gets spread in all direction. The light emitted by LED is also monochromatic because only one color means single wavelength. But light emitted by torch, bulb or tube light is not monochromatic because it consists of many wavelengths and it also gets spread in all direction.

Coherent Laser Light

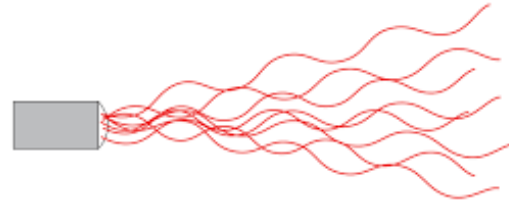

Incoherent LED Light

LASER light is Coherent and Monochromatic

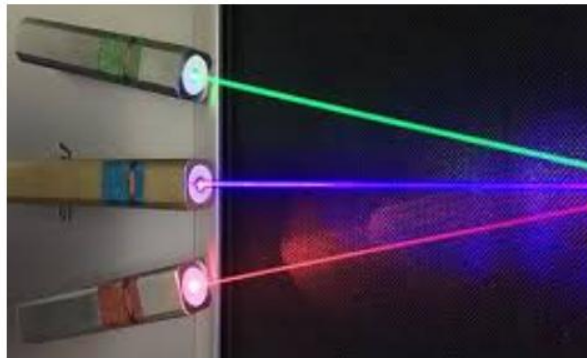

As shown below the white light emitted by torch is combination of light of all colors. It is like when all colors are mix at that time resultant color is white. Therefore, it is not monochromatic and non-coherent.

If this white light is emitted by LED then it does not have the combination of all colors but gets spread in all directions therefore it is monochromatic but non coherent.

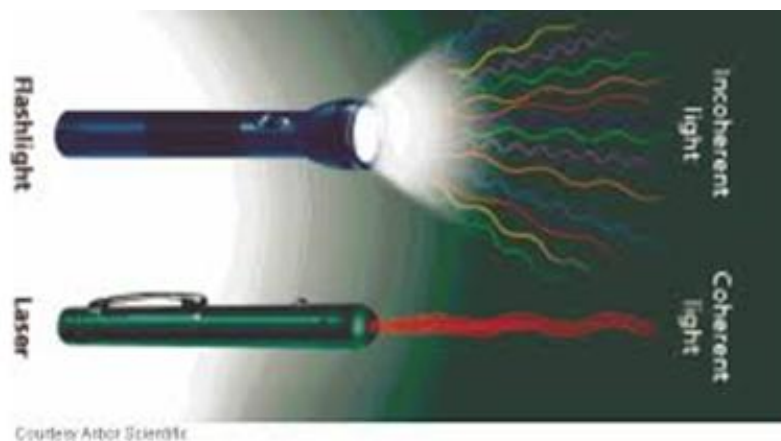

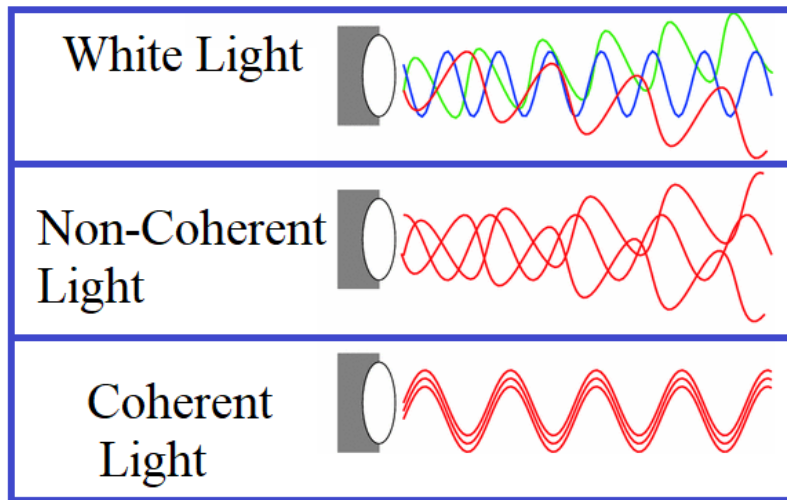

As shown below the colour of light emitted by LED (Light Emitting Diode) is Red. This is due to single wavelength which is associated to red color. But the phase angle of each ray is not constant. Therefore this light gets spread in all direction and it does not propagates in only one direction. Three arrows indicates the phase difference between the emitted rays of light.

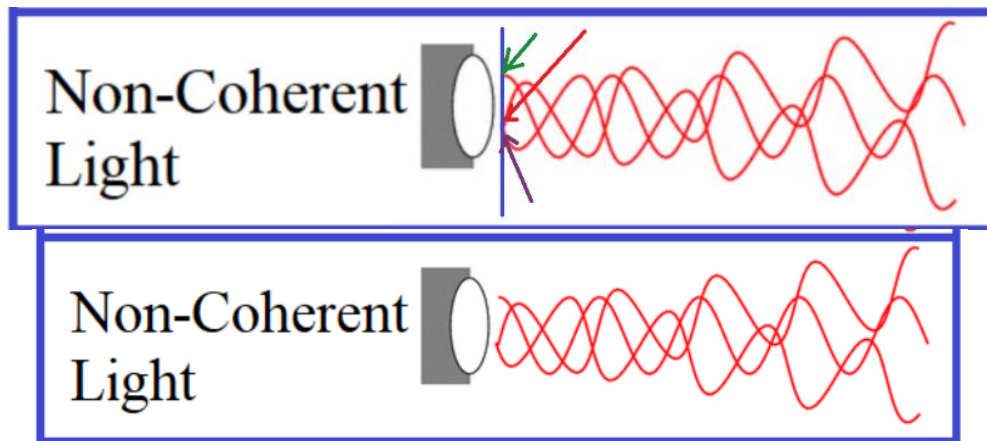

Fiber Optic Cable consist of Core and Cladding and the medium through which the light signal passes is Core. Core as well as Cladding is made from Glass material of particular Refractive Index.

IV. STRUCTURE OF OPTIC FIBER CABLE

As shown below Optic fiber cable consists of 1) Protective Jacket 2) Cladding and 3) Core.

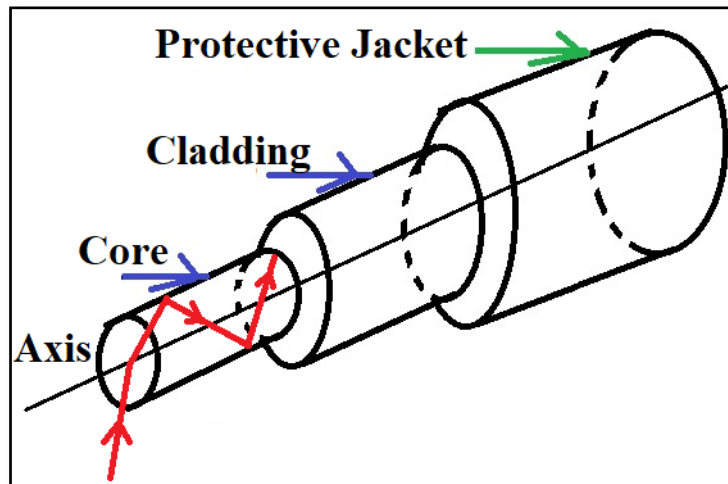

1. Refractive Index (RI), Snell’s law, Critical Angle (θ_c) and Total Internal Reflection (TIR)

- The Refractive Index (**RI**) is indicated by symbol (**n**) and in optic fiber cable, Refractive Index of Core material (**n₁**) is always greater than RI of cladding material (**n₂**).
- Due to “**n₁ > n₂**” the ray of light focused/launched in to core gets strike at the junction of core and cladding and it reflects back in to the core medium.
- The ray of light is always focused / launched in to Core of fiber. When this ray of light gets strike at the junction of core and cladding at that time “**refraction**” of this ray in to cladding is zero and “**reflection**” in to core is maximum. It will happen if the Ray of light satisfies the condition of “**Critical Angle θ_c** ”.
- To have zero “**refraction**” the angle of refracted ray along with normal drawn at the junction of core and cladding must be ninety (90) degree.

2. Definition of Refractive Index (RI): Refractive Index is the ratio of Speed of light in free space to the Speed of light in that material.

Refractive Index (RI) is very important parameter and it is ratio of Speed of Light In free Space to the Speed of light in a particular medium.

It is indicated by symbol (**n**)

$$RI = \frac{\text{Speed of Light In free Space}}{\text{Speed of light in a particular medium}}$$

$$n_0 = RI \text{ of Air} = 1, \quad RI \text{ of Glass} = 1.5$$

$$RI \text{ of Diamond} = 2.417 \quad RI \text{ of Water} = 1.333$$

Medium	Refractive Index
Vacuum	1.00000 (exactly)
Air	1.00029
Alcohol	1.329
Diamond	2.417
Glass	1.5
Ice	1.309
Sodium Chloride (Salt)	1.544
Sugar Solution (80%)	1.49
Water (at 20 degree Centigrade)	1.333

3. **Snell’s Law and Total Internal Reflection (TIR):** As shown below consider an Incident Ray of Red color is focused in to glass material having Refractive Index (RI) “ n_1 ” (Medium-I). The another material above the glass is having Refractive Index (RI) “ n_2 ” (Medium-II). Let us draw the normal which is perpendicular to the junction of two materials having Medium-I and Medium-II as shown below.

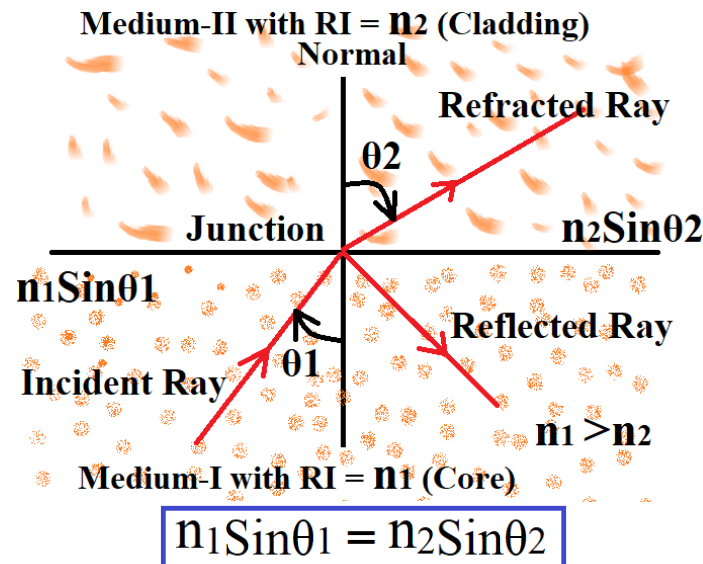

As shown above “ θ_1 ” is the angle between incident ray and normal of material having RI, “ n_1 ” . “ θ_2 ” is the angle between the refracted ray and normal of material having RI, “ n_2 ” .

When θ_1 is increased at that time θ_2 also increases and refraction is reduced. If the angle of refracted ray is 90° in that case refraction is zero and reflection is maximum as shown below.

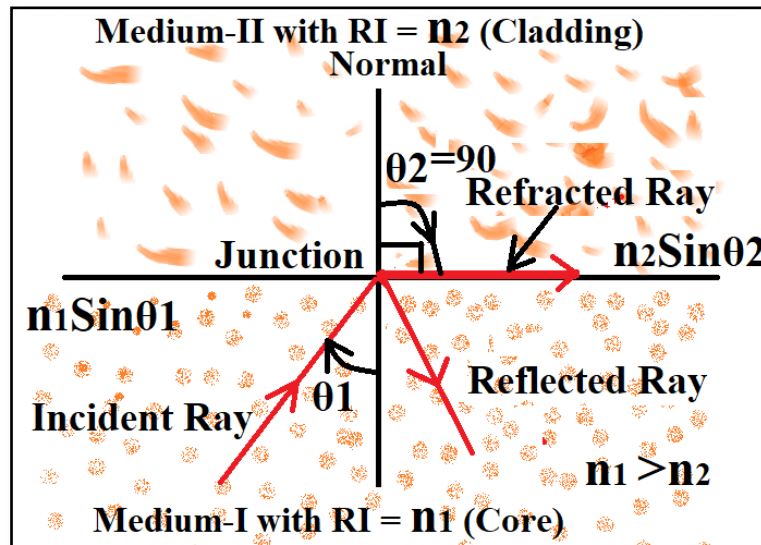

As shown below reflected ray is once again reflected by placing the material having Refractive Index (RI) of “ n_2 ” just below the material having Refractive Index (RI) of “ n_1 ”.

Let us consider the material having Refractive Index (RI) as “ n_1 ” is **Core** and the material having Refractive Index (RI) as “ n_2 ” as **cladding**.

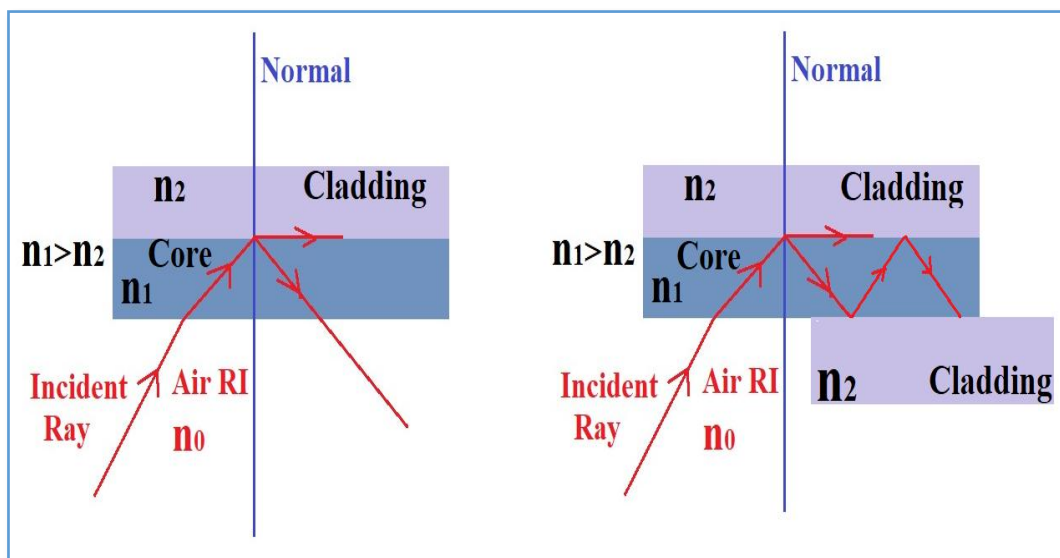

As shown below Core is surrounded by cladding and the Incident ray of light gets multiple times reflected back in to core from the junction of core and cladding and this is called as total internal reflection (TIR). But it will happen if and only if the Incident ray of light satisfies the condition of Critical Angle (θ_c).

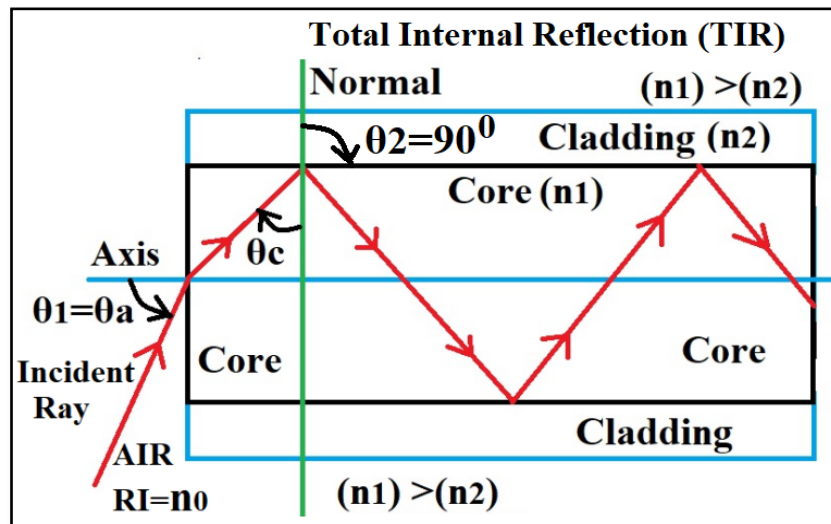
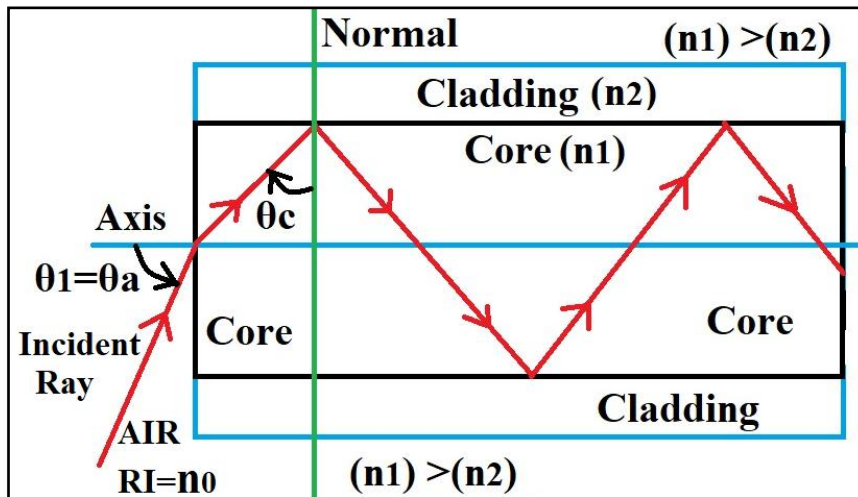

As shown above ray of light is launched in to Core of Fiber Optic Cable (FOC) through air. The Refractive Index (RI) of Air is $n_0=1$.

Here θ_1 is the angle between incidence ray and Axis of FOC. Here normal is Axis of FOC, because the air acts as one material (on LHS) and core of FOC acts as second material (on RHS).

When ray enters in to fiber at that time it gets bend. This ray gets strikes at the junction of core and cladding.

The second normal is drawn at the junction of core and cladding. Applying the Snell's law at the junction of Core and Cladding, where the Refractive Index (RI) of Core is n_1 and Refractive Index (RI) of Cladding is n_2 .

Therefore

$$n_1 \sin \theta_1 = n_2 \sin \theta_2$$

If $\theta_2=90^\circ$ then $\text{Sin}(90^\circ)=1$

$$\text{Sin}\theta_1 = \frac{n_2}{n_1}$$

$$\theta_1 = \text{Sin}^{-1}\left(\frac{n_2}{n_1}\right)$$

θ_1 is called as Critical angle (θ_c) because at 90° the refraction is Zero and Reflection is maximum.

$$\text{Critical angle} = \theta_c = \text{Sin}^{-1}\left(\frac{n_2}{n_1}\right)$$

If incident ray Satisfies this angle then that ray propagates by the principal of Total Internal Reflection (TIR).

When the angle of incidence ray is greater than or equal to the Ccritical angle (θ_c), then the Ray of light is totally reflected back into the core. This phenomenon is called total internal reflection (TIR).

This phenomenon of total internal reflection is used to guide the ray of light in optical fiber cable. As explain above if incident ray Satisfies the condition of **critical angle (θ_c)** then that ray propagates through the entire length of FOC due to Total Internal Reflection (TIR).

Cylindrical view of Core and cladding material.

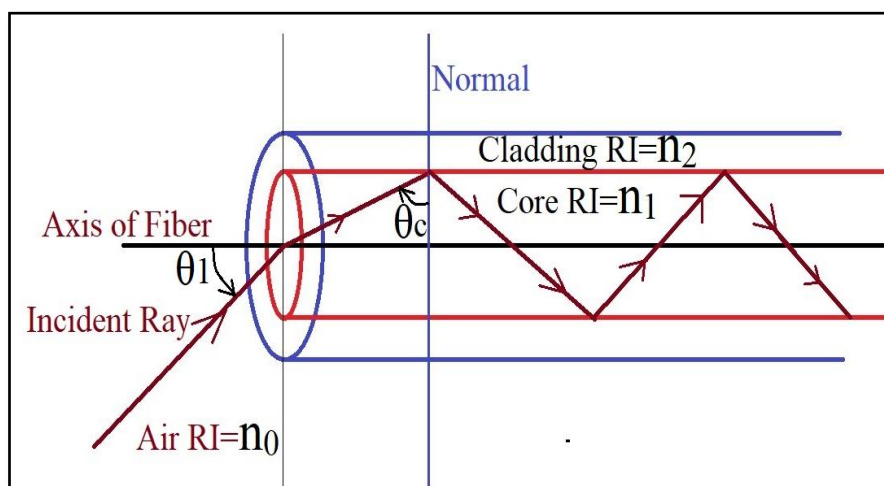

Number of rays can be launch in to core as shown below.

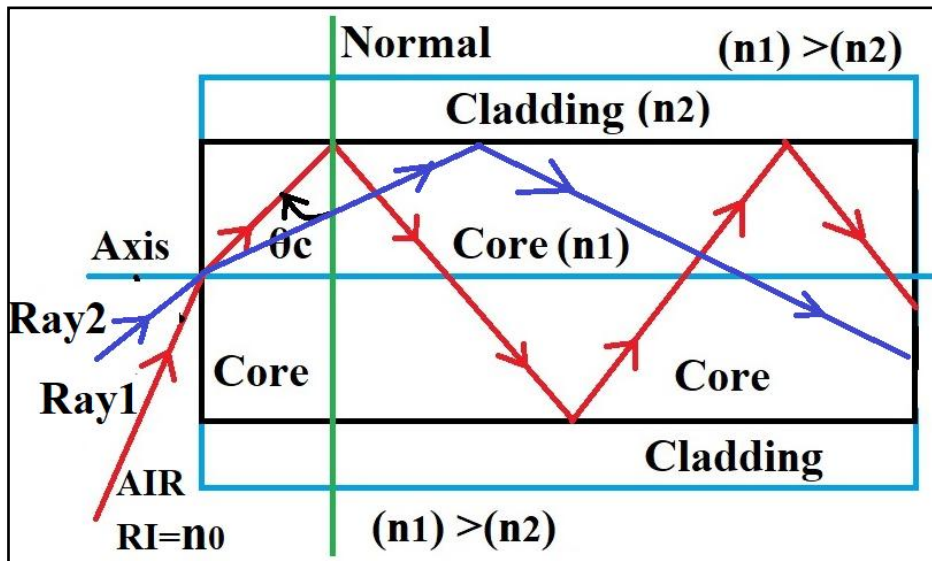

The time required to travel for the ray of light in a given medium depends on Refractive Index (RI) of that medium, if Refractive Index (RI) is large in that case more time is required for the ray to travel. Large Refractive Index (RI) means medium is dense.

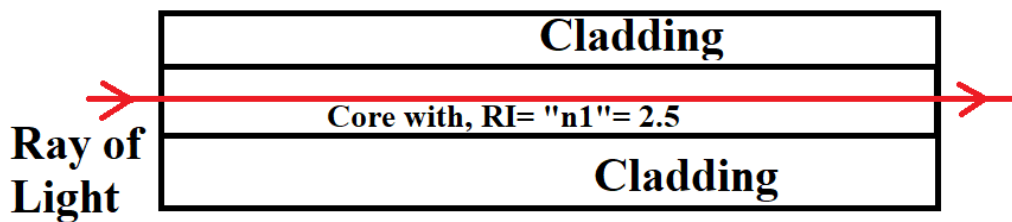
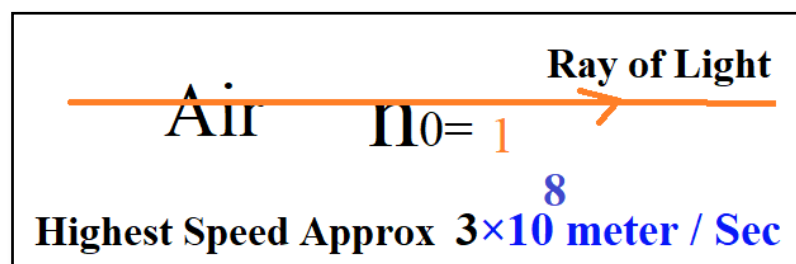

Diagram-1

As shown in above diagram-1 the ray of light is passing through the Refractive Index (RI) of of core material of 2.5 and in diagram-2 the ray of light is passing through the Refractive Index (RI) of of core material of 1.5. Therefore the speed of Ray of light through the Refractive Index (RI) of of core material of 1.5 is very large. If the length of fiber optic cable is same then Ray of light in diagram number 2 will come out first.

As shown below the Ray of light is passing through the free space (Air) having Refractive Index (RI) as One and the speed is 3×10^8 meter per second.



V. MATERIALS USED FOR FIBER OPTIC CABLE

- GeO_2 - SiO_2 Core, SiO_2 Cladding
- P_2O_5 - SiO_2 Core, SiO_2 Cladding
- SiO_2 Core, B_2O_3 - SiO_2 Cladding

SiO_2 is Silicon Dioxide, GeO_2 is Germanium dioxide, also called as Germanium (IV) oxide, **P_2O_5 is Phosphorus pentoxide and B_2O_3 is Boron trioxide or diboron trioxide** is the oxide of boron. It is a colorless transparent solid, almost always glassy (amorphous), which can be crystallized.

- 1. Advanced Materials:** Several materials, with attenuation coefficients far smaller than that of silica glass, are being used in experimental optical systems in the mid-infrared region. These include heavy-metal fluoride glasses, halide-containing crystals, and chalcogenide glasses. For these materials, the infrared absorption band is located further in the infrared than in silica glass so that mid-infrared operation, with its attendant reduced Rayleigh scattering (which decreases as $1/\lambda^4$), is possible.

Attenuation's as small as 0.001 dB/km are expected to be achievable with fluoride-glass fibers operating at wavelengths in the 2 to 4 μm band. If these extremely low-loss materials are economically made into fibers, and if suitable semiconductor light sources are perfected for room-temperature operation in the mid-infrared band, repeaterless transmission over distances of several thousand, instead of hundreds, of kilometers would become routine.

Manufacturing techniques for Fiber Optic Cable

- OVD: Outside Vapour Deposition
- MCVD: Modified Chemical Vapour Deposition
- PCVD: Plasma Activated Chemical Vapour Deposition
- VAD: Vapour Phase Axial Deposition

In Optic fiber communication always an information signal (Audio, Video, text) which is available in Non Electric signal is converted in to an Electric signal and then it is converted in to Optical Signal.

In Optic fiber communication a Ray of Light of particular wavelength (highly monochromatic) is used to communicate (Carry) the information signal. Therefore Optical Converters are required (Electric to light and Light to Electric).

In the first generation of Fiber Optic Communication the Light (Optical) sources of 600 to 700 nanometer was used, in second generation it was 900 to 1100 nanometer and in third generation it is 1500 to 1700 nanometer.

If we calculate the frequency of optical signal by using the relation between $C = \gamma \times \lambda$, where C is velocity of light, γ is frequency and λ is wavelength. The frequency is always in GHz and therefore the bandwidth of OFC is very very large.

Acceptance angle and Acceptance Cone: We know that if incidence ray Satisfies the condition of critical angle (θ_c) [at the junction of core and cladding] then that ray propagates through the entire length of FOC due to Total Internal Reflection (TIR).

Therefore it is necessary to launch the incident ray in to fibre with specific angle. We also know that Critical angle (θ_c) is the angle of incident ray with normal at the junction of core and cladding.

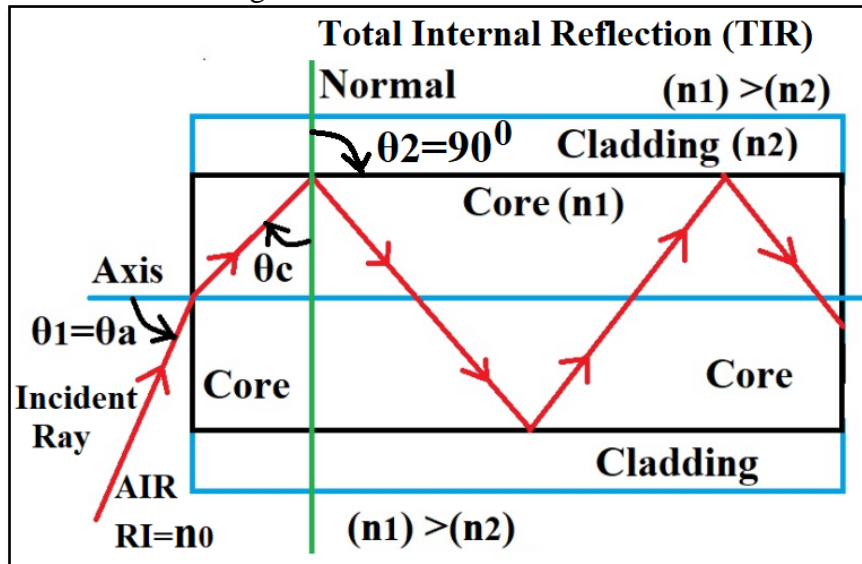

By applying Snell's law at the Core and Cladding

$$n_1 \sin \theta_1 = n_2 \sin \theta_2$$

$$\text{If } \theta_2 = 90^\circ \text{ then } \sin(90^\circ) = 1$$

$$\text{Therefore } n_1 \sin \theta_1 = n_2$$

$$\sin \theta_1 = n_2 / n_1$$

$$\theta_1 = \sin^{-1}(n_2 / n_1)$$

But $\theta_1 = \theta_c = \text{Critical Angle}$

$$\theta_c = \sin^{-1}(n_2 / n_1)$$

- Acceptance Angle:** Acceptance angle (θ_a) is the maximum angle of incident ray with the axis of fiber optic Cable (FOC), which satisfies the condition of critical angle (θ_c) upon entering in to fiber optic Cable. Acceptance angle is denoted by symbol (θ_a).

If the angle of incident ray is less than Acceptance angle (θ_a) then that ray propagates through the entire length of Fiber Optic Cable (FOC) due to Total Internal Reflection (TIR) because that ray also satisfies the condition of Critical angle (θ_c).

As shown below the Ray-X is launch in to fiber such that, angle of this ray is less than Acceptance angle (θ_a). But the Ray-Y is having the angle greater than Acceptance

angle (θ_a) therefore Ray-Y will get lost eventually at the junction of core and cladding due to refraction. If the angle of an Incident ray is very very large than the Acceptance angle (θ_a) then that ray gets trap in to Fiber Optic Cable (FOC).

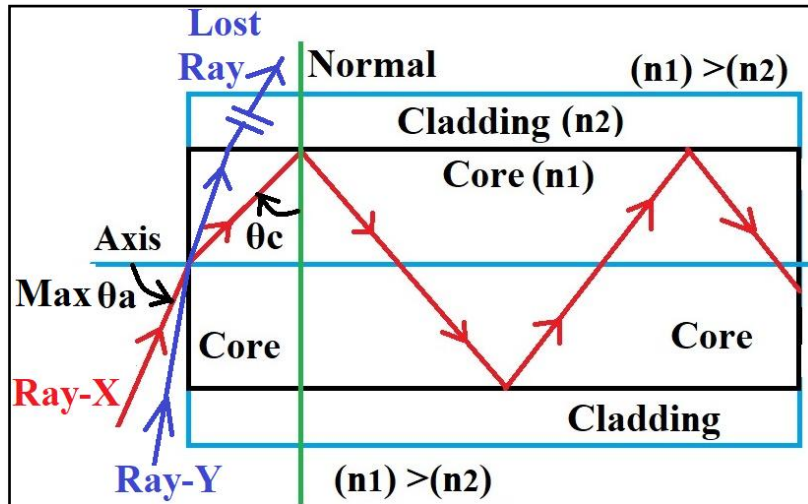

Acceptance angle is the maximum angle of incident ray (θ_a) to the axis of FOC, at which ray may enter in to FOC in order to get propagate.

- 3. Acceptance Cone:** It is the cone in all planes through which an incidence ray is launch in to fiber such that it Satisfies the condition of Critical angle (θ_c).

As shown in the diagram of **Acceptance angle**, Ray-X and Ray-Y are launch in vertical plane (Y-plane) and below the Axis of fiber. But these rays can be launch in the same plane in apposite direction that is above the axis of fiber.

As shown below if you consider the “n” number of planes in that case formation of Cone takes place and this cone in all planes is nothing but Acceptance Cone.

As shown below the conical angle is ($2\theta_a$).

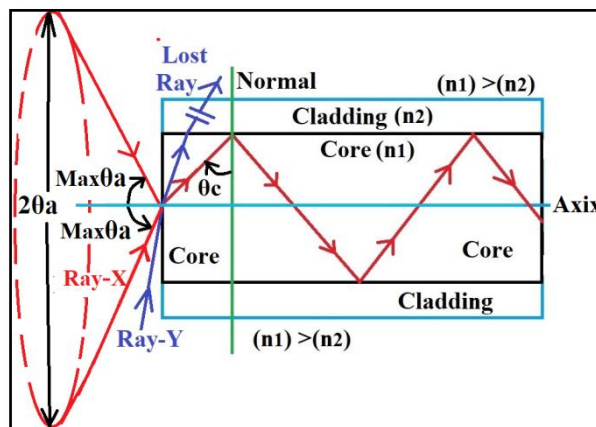

As shown below Ray-A, Ray-B and Ray-C entering in to FOC is having the angle less than $\text{Max}(\theta_a)$ therefore all these rays also satisfies the condition of Critical angle (θ_c) upon entering in to fiber.

Therefore, all rays propagate through the entire length of FOC due to Total Internal Reflection (TIR).

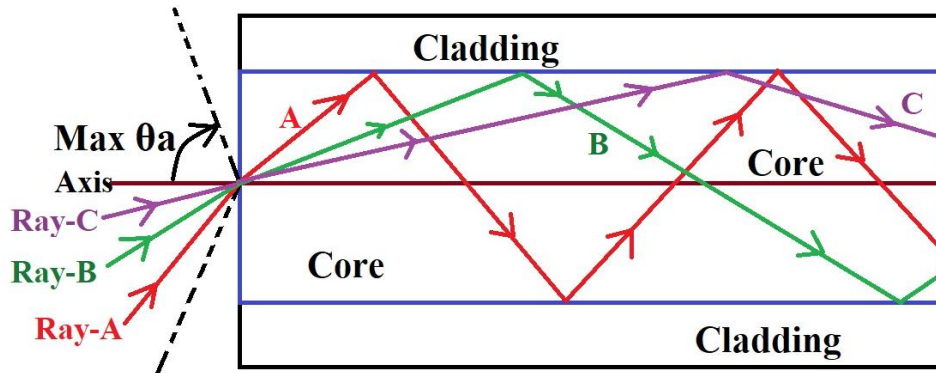

Ray-A will have maximum number of reflections and Ray-C will have minimum number of reflections. Ray-C will travel fast and it will come out in less time as compare to all other Rays.

- Numerical Aperture (NA):** Ability of fiber optic cable to collect/gather the maximum number of ray in a particular angle is called as Numerical Aperture (NA).

The Numerical Aperture (NA) is measure of the light gathering ability of FOC.

It depends on RI of Core (n_1) and RI of Cladding (n_2).

Numerical Aperture (NA)

$$NA = \sqrt{n_1^2 - n_2^2}$$

It also depends on Acceptance angle (θ_a)

$$NA = \text{Sin}(\theta_a)$$

- Derivation for Numerical Aperture (NA):** Let us consider an Incidence Ray launch in to fiber which satisfies the condition of Critical Angle (θ_c) as shown below.

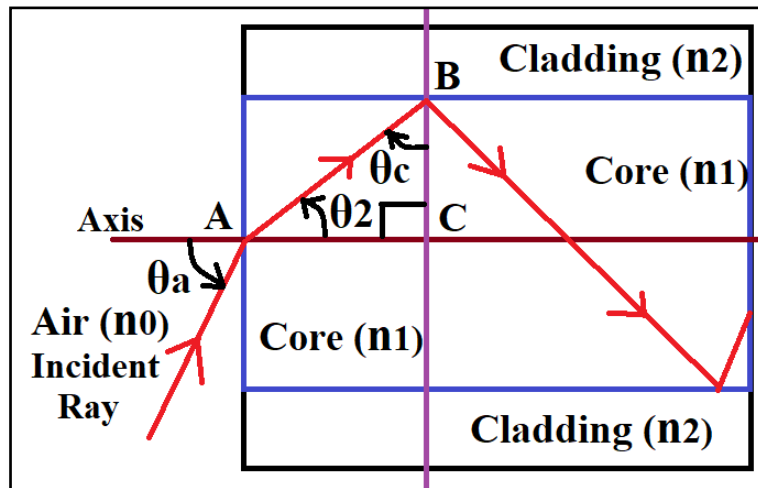

Apply Snell's law at the entry point of Incidence Ray, where Air with $RI=n_0$ and Core with $RI=n_1$ are acting.

$$\text{Therefore } n_0 \sin \theta_a = n_1 \sin \theta_2 \text{ -----(1)}$$

In diagram shown above Triangle ABC is Right Angle Triangle.

$$90^\circ = \theta_c + \theta_2 \text{ -----(2)}$$

$$\Pi/2 = \theta_c + \theta_2$$

$$\theta_2 = \Pi/2 - \theta_c \text{ -----(3)}$$

Substitute (3) in (1)

$$n_0 \sin \theta_a = n_1 \sin (\Pi/2 - \theta_c)$$

Now Using $\sin(A-B) = \sin A \times \cos B$

$$n_0 \sin \theta_a = n_1 (\sin \Pi/2 \times \cos \theta_c) \text{ -----(4)}$$

But $\sin \Pi/2 = 1$

$$n_0 \sin \theta_a = n_1 \times \cos \theta_c \text{ -----(5)}$$

Let us Replace Cos on RHS in terms of Sin

by using $\sin^2 \theta + \cos^2 \theta = 1 \text{ -----(6)}$

$$\cos^2 \theta = 1 - \sin^2 \theta$$

$$\cos^2 \theta_c = 1 - \sin^2 \theta_c$$

$$\cos \theta_c = \sqrt{1 - \sin^2 \theta_c} \text{ -----(7)}$$

Substitute equation (7) in equation (5)

$$n_0 \sin \theta_a = n_1 \sqrt{1 - \sin^2 \theta_c} \text{-----(8)}$$

But $\sin \theta_c = n_2/n_1$ **Because** $\theta_c = \sin^{-1}(n_2/n_1)$

$$\sin^2 \theta_c = (n_2^2/n_1^2) \text{-----(9)}$$

Substitute equation (9) in equation (8)

$$n_0 \sin \theta_a = n_1 \sqrt{1 - (n_2^2/n_1^2)} \text{-----(10)}$$

$$n_0 \sin \theta_a = n_1 \sqrt{\frac{n_1^2 - n_2^2}{n_1^2}} \text{-----(11)}$$

$$n_0 \sin \theta_a = \frac{n_1}{n_1} \sqrt{n_1^2 - n_2^2}$$

$$n_0 \sin \theta_a = \sqrt{n_1^2 - n_2^2}$$

But $n_0 = 1$

$$\sin \theta_a = \sqrt{n_1^2 - n_2^2} = \mathbf{NA}$$

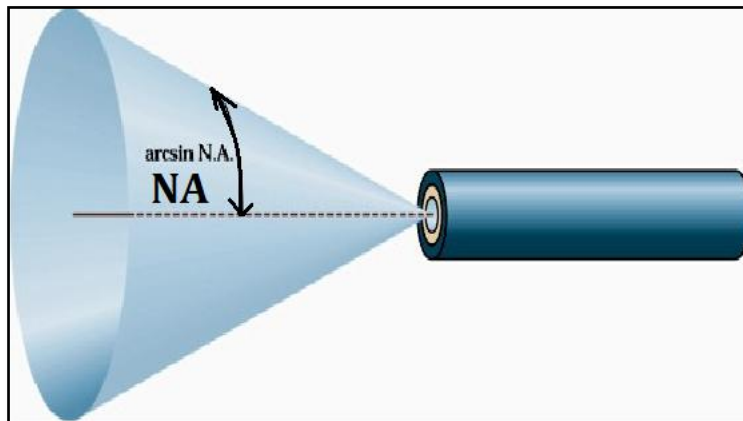

In above diagram “arcsin NA” means “ $\sin^{-1}(\text{NA})$ ”

6. How to Calculate Number of Modes in a Fiber?

Modes are sometimes characterized by numbers. Single mode fibers carry only the lowest-order mode, assigned the number 0. Multimode fibers also carry higher-order modes. The number of modes that can propagate in a fiber depends on the fiber’s numerical aperture (or acceptance angle) as well as on its core diameter and the wavelength of the light. For a step-index multimode fiber, the number of such modes, V , is approximated by

An optical fiber is characterized by one more important parameter known as V number more commonly called as normalized frequency. It is expressed as (**Number of Modes**): -

$$\text{Number of Modes} = V = \frac{2\pi a}{\lambda} \times NA$$

Where

$$NA = \sqrt{n_1^2 - n_2^2}$$

The V number is a dimensionless parameter which is often used in the context of Step-Index Fibers.

Where λ is the vacuum wavelength, a is the radius of the fiber core, and NA is the numerical aperture. The V number should not be confused with some velocity “v”, e.g. the phase velocity of light, and also not with the Abbe number, which is also sometimes called V-number.

$$\begin{aligned} \text{Normalized frequency} = \\ \text{Number of Modes} = V = \frac{2\pi a}{\lambda} \times NA \end{aligned}$$

$$\text{Number of Modes} = V = \frac{2\pi a}{\lambda} \times \sqrt{n_1^2 - n_2^2}$$

But

$$\begin{aligned} NA &= \sin(\theta_c) \\ \text{Number of Modes} = V &= \frac{2\pi a}{\lambda} \times \sin(\theta_c) \end{aligned}$$

Where “a” = Diameter of Core
 Radius of curvature of Fiber Optic Cable:

It is given by equation

$$R_c = \frac{3 \lambda n_1^2}{4 \pi \sqrt{n_1^2 - n_2^2}}$$

$$R_c = \frac{3 \lambda n_1^2}{4 \pi \cdot NA}$$

- **Example 1:** Calculate the critical angle θ_c . Given RI Core n_1 is 1.5 and RI Cladding n_2 is 1.25.

$$\text{Ans: } \theta_c = \sin^{-1}\left(\frac{n_2}{n_1}\right)$$

$$\theta_c = \sin^{-1}\left(\frac{1.25}{1.5}\right) = \sin^{-1}(0.833)$$

$$\text{critical angle} = \theta_c = \mathbf{56.40 \text{ degree}}$$

- **Example 2:** Calculate the RI Core n_1 Given critical angle $\theta_c = 45^\circ$, RI Cladding n_2 is 1.25.

$$\text{Ans: } \theta_c = \sin^{-1}\left(\frac{n_2}{n_1}\right)$$

$$45^\circ = \sin^{-1}\left(\frac{n_2}{n_1}\right)$$

$$\sin(45^\circ) = \left(\frac{n_2}{n_1}\right)$$

$$n_1 = n_2 / \sin(45^\circ)$$

$$n_1 = 1.25 / 0.707$$

$$n_1 = \mathbf{1.76}$$

- **Example 3:** Calculate the RI Cladding n_2 . Given critical angle $\theta_c = 35^\circ$, RI Core $n_1 = 1.5$.

$$\text{Ans: } \theta_c = \sin^{-1}\left(\frac{n_2}{n_1}\right)$$

$$35^\circ = \sin^{-1}\left(\frac{n_2}{n_1}\right)$$

$$\sin(35^\circ) = \left(\frac{n_2}{n_1}\right)$$

$$n_2 = n_1 \times \sin(35^\circ)$$

$$n_2 = 1.5 \times 0.57$$

$$n_2 = \mathbf{0.855}$$

- **Example 4:** A silica fiber with a core diameter large enough having RI of Core 1.5 and Cladding 1.47.

Calculate a) Critical angle b) Numerical Aperture c) Acceptance angle 4) Conical Angle.

Ans: a) Critical angle (θ_c):

**Given RI of Core n_1 is 1.5 and
RI of Cladding n_2 is 1.47.**

$$\theta_c = \sin^{-1}\left(\frac{n_2}{n_1}\right)$$

$$\theta_c = \sin^{-1}\left(\frac{1.47}{1.50}\right) = \sin^{-1}(0.98)$$

critical angle = $\theta_c = 78.5^\circ$

b) Numerical Aperture (NA):

**Given RI Core n_1 is 1.5 and
 RI Cladding n_2 is 1.47.**

$$NA = \sqrt{(n_1)^2 - (n_2)^2}$$

$$NA = \sqrt{(1.50)^2 - (1.47)^2}$$

$$NA = 0.30$$

c) **Acceptance angle (θ_a):**

**Given RI Core n_1 is 1.5 and
 RI Cladding n_2 is 1.47.**

We know that

$$n_0 \sin\theta_a = \sqrt{(n_1)^2 - (n_2)^2}$$

But $n_0 = 1$

$$\sin\theta_a = \sqrt{(n_1)^2 - (n_2)^2}$$

$$\theta_a = \sin^{-1}\sqrt{(n_1)^2 - (n_2)^2}$$

$$\theta_a = \sin^{-1}(0.30)$$

$$\theta_a = 17.4^\circ$$

D) **Conical Angle** = $2\theta_a$

$$= 2 \times 17.4^\circ$$

$$= 34.8^\circ$$

- **Example 5:** Calculate the NA Given RI Core $n_1=1.55$ and RI Cladding $n_2=1.50$.

Numerical Aperture (NA):

$$NA = \sqrt{(n_1)^2 - (n_2)^2}$$

$$NA = \sqrt{(1.55)^2 - (1.50)^2}$$

$$NA = 0.390$$

- **Example 6:** Calculate Acceptance angle Given RI Core $n_1=1.50$ and RI Cladding $n_2=1.45$.

Ans: We know that

$$\sin \theta_a = NA$$

$$\text{But } NA = \sqrt{(n_1)^2 - (n_2)^2}$$

$$\sin \theta_a = \sqrt{(n_1)^2 - (n_2)^2}$$

$$\text{Acceptance angle} = \theta_a$$

$$\theta_a = \sin^{-1} \sqrt{(n_1)^2 - (n_2)^2}$$

$$\theta_a = \sin^{-1} \sqrt{(1.50)^2 - (1.45)^2}$$

$$\theta_a = \sin^{-1}(0.15)$$

$$\theta_a = 8.626$$

- **Example 7:** Calculate the number of reflections of ray in one meter length of fiber optic cable. Given RI Core $n_1=1.50$, RI Cladding $n_2=1.49$ and core diameter is $50\mu\text{m}$.

Ans: As shown below the diameter of core is $50\mu\text{m}$, therefore $Y = \text{Half of Core diameter} = 25\mu\text{m}$.

Now we want to calculate the distance X at which first reflection takes place. So that we can calculate the number of reflections of ray in one meter length of fiber optic cable.

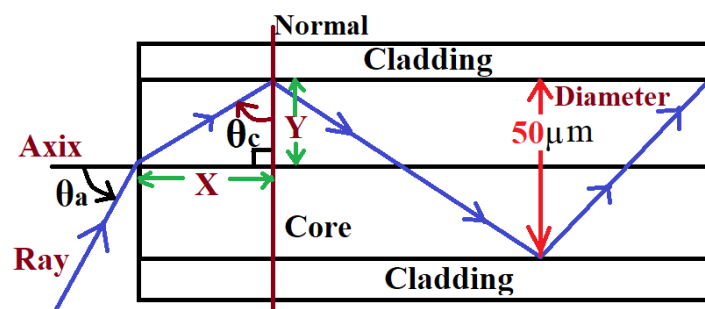

Let us use trigonometric equation for angle θ_c in terms of \tan ,
 because $\tan\theta_c = \text{front side}/\text{adjacent side} = X/Y$,

$$\text{critical angle, } \theta_c = \text{Sin}^{-1}\left(\frac{n_2}{n_1}\right)$$

$$\theta_c = \text{Sin}^{-1}(1.49/1.50)$$

$$\theta_c = \text{Sin}^{-1}(0.99) = 81.89^\circ$$

$$\theta_c = 81.89^\circ$$

$$\tan\theta_c = \tan(81.89^\circ) = 7.017$$

$$\tan\theta_c = X/Y, \text{ But } \tan\theta_c = 7.017$$

$$\text{therefore } 7.017 = X/Y$$

$$X = 7.017 * Y, \text{ But } Y = 25\mu\text{m}$$

$$\text{therefore } X = 7.017 * 25\mu\text{m}$$

At distance X first reflection takes place, therefore Total number of reflections in one meter length can be calculated by equating.

$$\text{First Reflection} = 7.017 * 25\mu\text{m}$$

$$??\text{reflections} = 1 \text{ meter}$$

$$\text{First Reflection} * 1 \text{ meter} = ??\text{reflection} * 7.017 * 25\mu\text{m}$$

$$??\text{reflection} = \frac{1 \text{ meter}}{7.017 * 25\mu\text{m}}$$

$$??\text{reflection} = \frac{1 \text{ meter}}{175.425\mu\text{m}}$$

$$??\text{reflection} = 0.005700 * 10^6$$

$$??\text{reflection} = 5700$$

Total numbers of reflections on one meter length are 5700.

- **Example 8:** Calculate alpha and beta angle in diagram shown below.

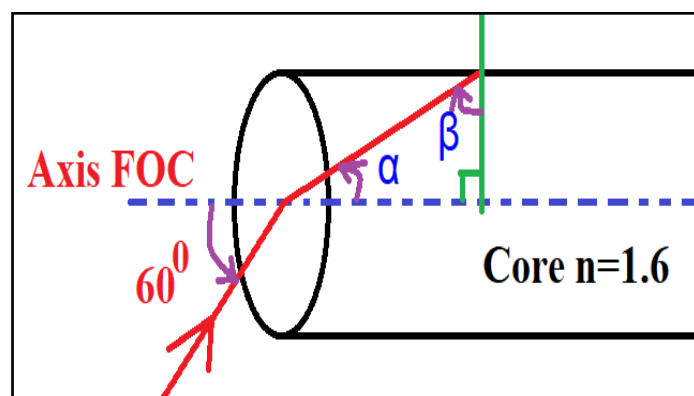

Answer: Applying Snell's law at the interface of Air and Core we can write.

$$\underline{n_0 \sin 60} = \underline{n_1 \sin \alpha}$$

- **Substitute all known values we will get value of Alpha**

$$\underline{n_0 \sin 60} = \underline{n_1 \sin \alpha}$$

$$\sin 60 / \sin \alpha = n_1$$

$$1.6 = .86 / \sin \alpha$$

$$\sin \alpha = .86 / 1.6 = 0.54$$

$$\alpha = 32.8$$

- **Applying logic for right angle triangle we can write**

$$\alpha + \beta = 90^0$$

Therefore

$$\beta = 90^0 - 32.8^0 = 57.2^0$$

III. TYPES OF OPTICAL FIBER OPTIC CABLES

Optical fiber is a long thin transparent dielectric material which carries Electromagnet (EM) waves of visible light and light of Infra-Red (IR) frequencies from one end to the other end of the fiber by means of TIR (Total Internal Reflection). The light in visible frequency range only having Electromagnet (EM) properties and Infra-Red (IR) does not possess Electromagnet (EM) properties

NOTE: Glass or Plastic is used as Dielectric material in optical fiber cables.

Optical fiber cable works as Wave guide which passes the light signal. The light signal may be television signals, digital data of computers, voice or video signal in television to any desired distance from one end to the other end of the fiber.

1. Optical Fiber Consists of Three Sections

- **Core:** It is an inner cylindrical material made up of glass or plastic.
- **Cladding:** It is a cylindrical shell of glass or plastic material in which Core is inserted.
- **Protective Jacket:** The Cladding is enclosed in polyurethane jacket and it protects the fiber from surroundings.

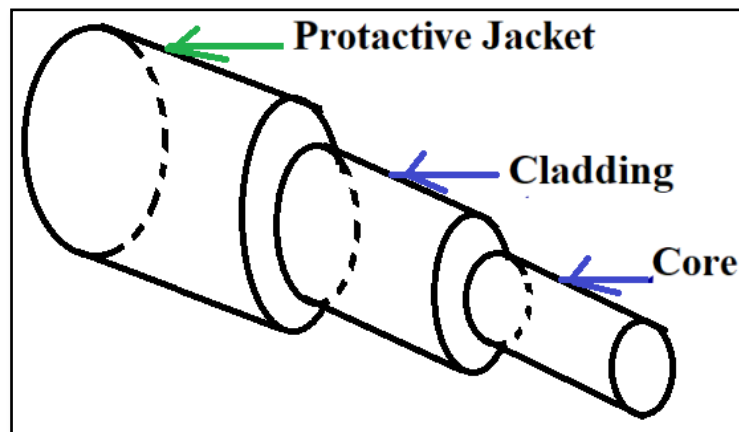

2. Optical Fiber Cables are Classified

- Single mode (mono mode) Step Index fiber optic cable
- Multi mode Step Index fiber optic cable
- Multi mode Graded Index fiber optic cable
- **Single mode Step Index:** As the name suggest Single Mode, in this fiber only one (signal) Ray of Light can be transmitted. Therefore, the use of single frequency is possible in Single Mode Step Index fiber.

As the name suggest Step Index in this fiber there is sudden change in Refractive Index of Core (n_1) and Cladding (n_2). ($n_1 > n_2$). The RI is constant for the core in this fiber.

In Single Mode, the ray of light propagates in parallel to the axis of fiber and there is no multiple reflection of ray. Hence it is called single mode step index fiber. Due to only one ray which is transmitted from one end to the other end in parallel to Axis of FOC, in this fiber interference of signal does not takes place.

The core diameter of this fiber is about 8 to 10 μm (Equal to Hair diameter of Human) and the outer diameter of cladding is 60 to 70 μm .

These are extensively used because distortion and transmission losses are very less. Highly directive source of light that is LASER is required.

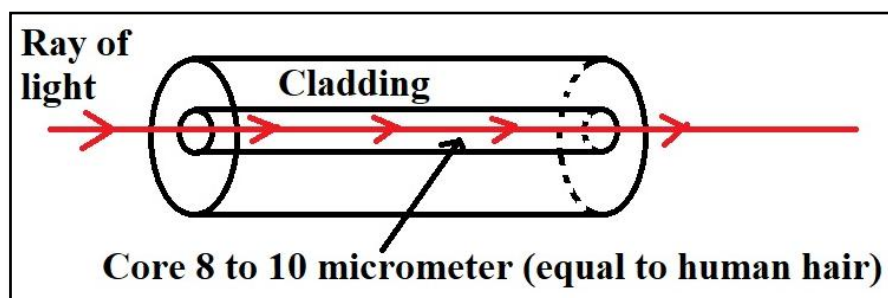

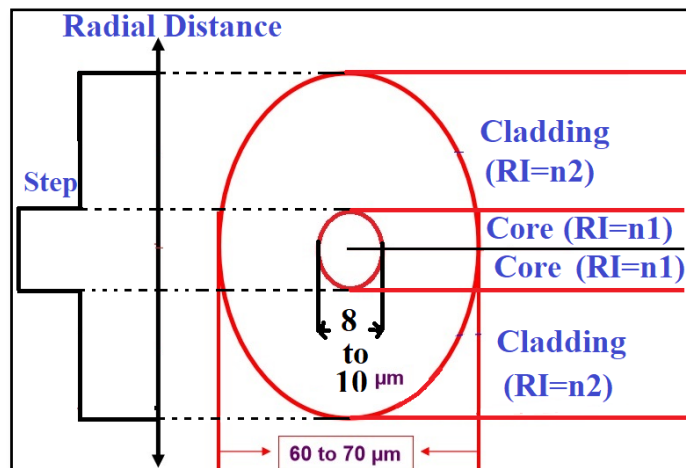

As shown above the core size of single mode fibers is small. The core size is typically around 8 to 10 micrometers (μm). A fiber core of this size allows only the fundamental or lowest order mode to propagate around a 1300 nanometer (nm) wavelength. Single mode fibers propagate only one mode, because the core size approaches the operational wavelength (λ). The value of the normalized frequency parameter (V) relates core size with mode propagation.

In single mode fibers, V is less than or equal to 2.405. When $V \leq 2.405$, single mode fibers propagate the fundamental mode down the fiber core, while high-order modes are lost in the cladding. For low V values (≤ 1.0), most of the power is propagated in the cladding material. Power transmitted by the cladding is easily lost at fiber bends. The value of V should remain near the 2.405 level.

Single mode fibers have a lower signal loss and a higher information capacity (bandwidth) than multimode fibers. Single mode fibers are capable of transferring higher amounts of data due to low fiber dispersion. Basically, dispersion is the spreading of light as light propagates along a fiber.

Signal loss depends on the operational wavelength (λ). In single mode fibers, the wavelength can increase or decrease the losses caused by fiber bending. Single mode fibers operating at wavelengths larger than the cutoff wavelength lose more power at fiber bends. They lose power because light radiates into the cladding, which is lost at fiber bends. In general, single mode fibers are considered to be low-loss fibers, which increase system bandwidth and length.

- **Single mode (mono mode) Step Index Advantages**

- Minimum dispersion therefore Pulse at Input can be reproduced at Output very accurately.
- Very less attenuation therefore it can be use for very long distance without using repeaters.
- Large bandwidth and high data transfer rate because ray travels without reflections.

- **Single mode (mono mode) Step Index Disadvantages**

- Due to very less core diameter of 8 to 10 micrometer, it is very difficult to couple light signal in to this fiber optic cable.
- Highly directive light source such as LASER is required.
- Interfacing modules required for this cable are more expansive.

3. Multi-Mode Step Index

- **Multi Mode Step Index Fiber Optic Cable:** As the name suggests Multi Mode, in this fiber many signals (Rays of Light) can be transmitted. Therefore, the use of multiple frequencies is possible in Multi-Mode Step Index fiber.

As the name suggest Step Index in this fiber there is sudden change in Refractive Index of Core (n_1) and Cladding (n_2), ($n_1 > n_2$). The RI is constant for the core in this fiber.

In Multi-mode, many rays of light propagates in fiber due to **TIR (Total Internal Reflection)**. The core diameter of this fiber is about 100 to 200 micrometer (μm) and the outer diameter of cladding is 100 to 150micrometer (μm). Several signals can be transmitted and several frequencies are used to modulate the number of information signals.

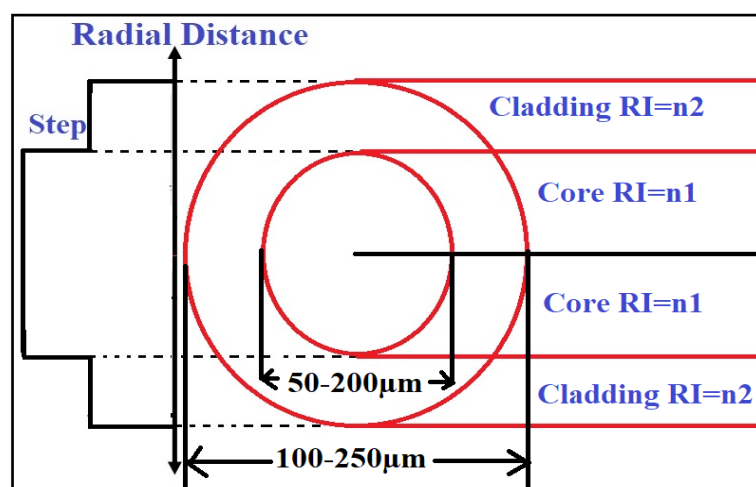

As their name implies, multimode fibers it can support for propagation of more than one mode (approx. 100 modes). The number of modes propagated depends on the core size and numerical aperture (NA). As the core size and NA increase, the number of modes increases. Typical values of Numerical Aperture (NA) is from 0.20 to 0.29.

A large core size ($>10\mu\text{m}$) and a higher Numerical Aperture (NA) have several advantages. Launching or focusing of light due to more core diameter becomes easy. The higher NA and the larger core size make it easier to make fiber connections. During fiber splicing, core-to-core alignment becomes less critical.

Another advantage is that multimode fibers permit the use of light-emitting diodes (LEDs). Single mode fibers typically must use LASER diodes. LEDs are cheaper, less complex, and last longer. LEDs are preferred for most applications.

Multimode fibers also have some *disadvantages*. As the number of modes increases, the effect of intermodal (Modal) dispersion increases. Intermodal dispersion (Modal) means that modes (Ray of light) come at the output of fiber optic cable is at slightly different times. This time difference causes the light pulse to spread as shown below.

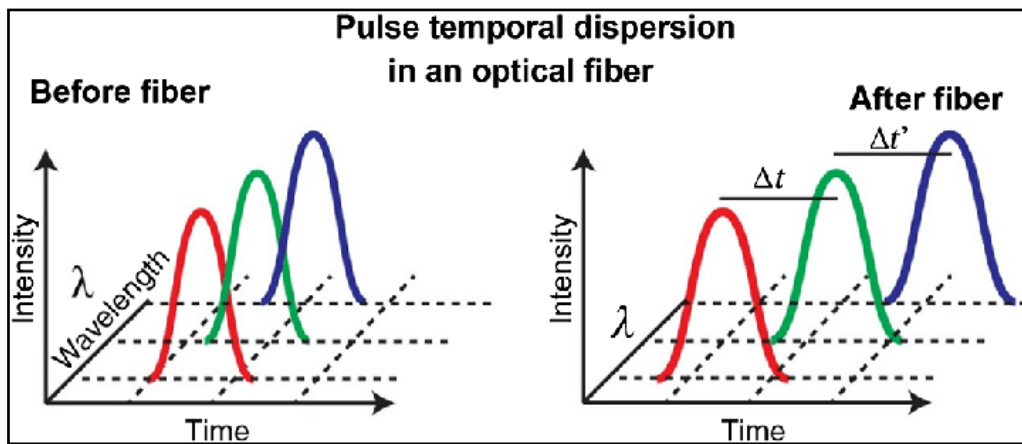

Modal dispersion affects system bandwidth. Fiber manufacturers adjust the core diameter, NA, and index profile properties of multimode fibers to maximize system bandwidth.

Sr.No.	Single Mode Fiber	Multi-Mode Fiber
1	Supports only one mode. Only one ray of light can pass.	Supports many modes. Many rays of light can pass.
2	Smaller Core diameter. 8 to 10 micrometers.	Large Core diameter. 50 to 200 micrometers.
3	Transmission losses are small.	Transmission losses are more.
4	Used for long distance communication	Used for short distance communication
5	They are mostly made from glasses	They are mostly made from plastic fiber.
6	They are by default step index	They can be step index or Graded Index
7	Minimum dispersion and less attenuation	Comparatively large dispersion and large attenuation
8	Very Large Band Width	Comparatively less

4. Multi-mode Graded Index: As the name suggest Multi Mode, in this fiber many signals (Rays of Light) can be transmitted. Therefore, the use of multiple frequency is possible in Multi-Mode Step Index fiber.

As the name suggest **Graded Index** in this fiber Refractive Index of core is not constant. The Refractive Index of core goes on gradually decreasing form the Axis of FOC (Fiber Optic Cable) towards the Junction of Core and Cladding. The Refractive Index is maximum at the axis of FOC (Fiber Optic Cable).

As shown below the core is divided in to many parts such as **nx, ny ,nz and nw**. The Refractive Index of core is not constant and Refractive Index is divided in to **nx, ny ,nz and nw**. Where **nx > ny > nz > nw**. The Refractive Index of core goes on gradually decreasing form the Axis of FOC(Fiber Optic Cable) towards the Junction of Core and Cladding.

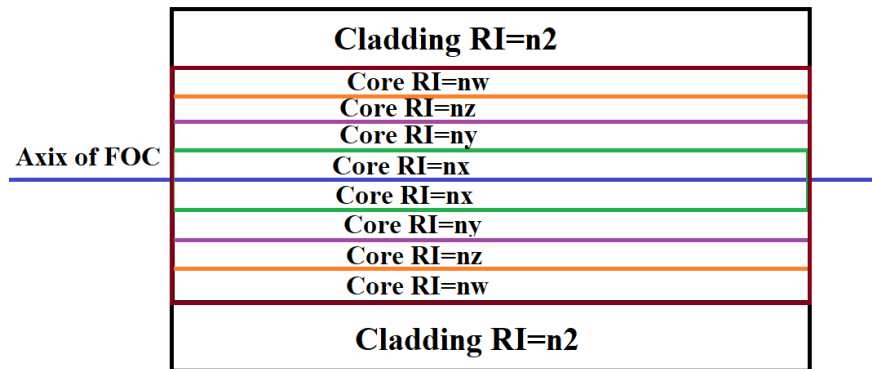

In this fiber many signals (Rays of Light) can be transmitted. Therefore, the use of multiple frequency is possible in Multi-Mode Graded Index fiber.

As we go radically away from center of the core, the Refractive Index of core goes on decreasing slowly towards the junction of Core and Cladding.

The core diameter of this fiber is about 100 to 200µm and the outer diameter of cladding is 100 to 150µm.

Several signals can be transmitted Several frequencies used to modulate the signal. The prorogation of Ray of light is due to refraction in core. The Ray of light reflects back in tore at the junction of Core and Cladding.

Due to Gradual decrease in refractive Index of core, the Ray of light travel in parabolic shape as shown below the Ray-A and Ray-B both travels in parabolic shape.

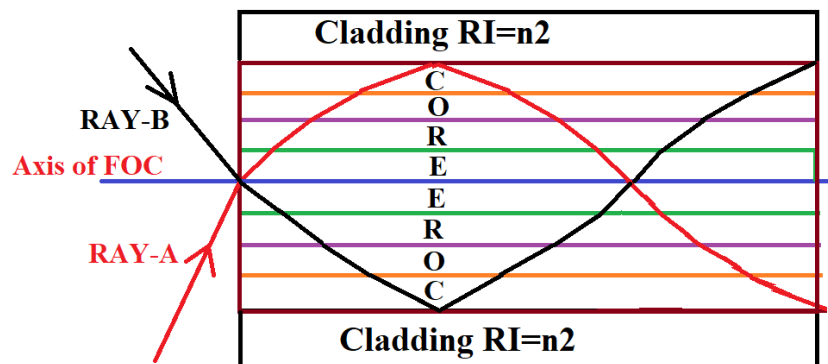

As shown below, if the Ray of light “RAY-C” is incident such that it travels along the Axis of FOC (Fiber Optic Cable) then that Ray of light travels in denser medium (RI= n_x , High Refractive Index), because the Refractive Index is Maximum at Axis of FOC ($n_x > n_y > n_z > n_w$).

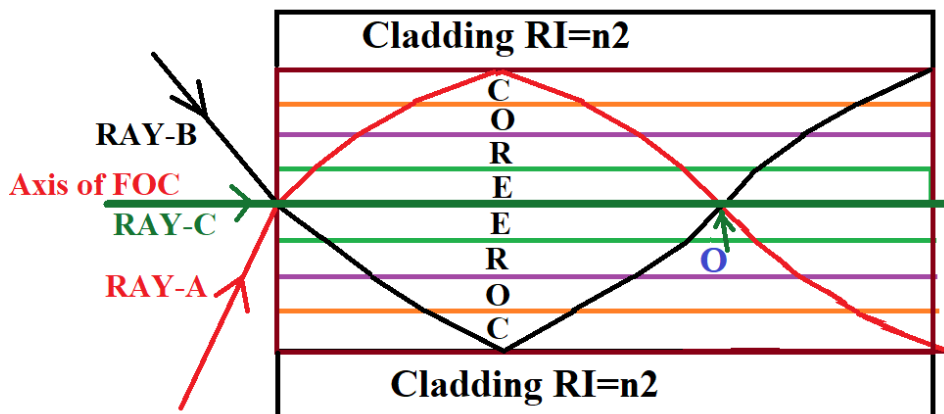

As shown above all three Rays namely “RAY-A”, “RAY-B” and “RAY-C” meets at the point “O”. The “RAY-A” and “RAY-B” takes the longer path and travels the longer distance before they come at the point “O”.

The “RAY-A” and “RAY-B” gets travel in different planes as well as different Refractive Index. But “RAY-A” and “RAY-B” travels through the area where Refractive Index is less.

The speed of “RAY-A” and “RAY-B” is large as compare to the speed of “RAY-C” because the “RAY-C” travels through the area where Refractive Index is maximum (RI= n_x , High Refractive Index).

Therefore even though the “RAY-A” and “RAY-B” travels the longer distance and “RAY-C” travels short distance, all three RAY’S will meet at the point “O” at same time and all three RAY’S will come out from FOC at the same point

5. Refractive Index Profile of Multi mode Graded Index FOC

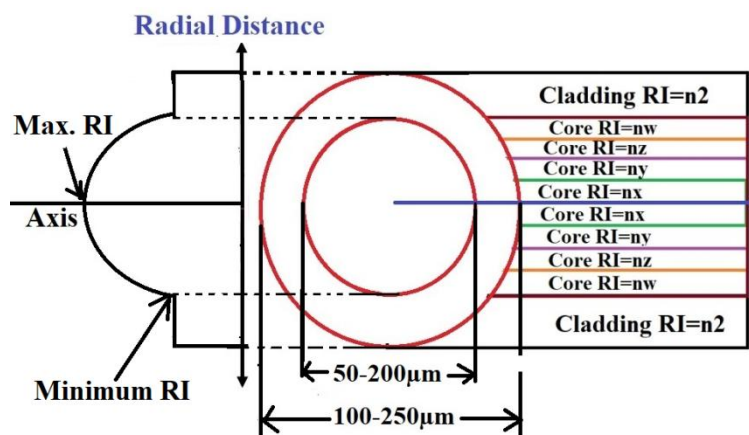

As shown above the parabolic curve on LHS indicates that the Refractive Index of core is maximum at the Axis of FOC and Refractive Index of core goes on gradually decreasing form the Axis of FOC (Fiber Optic Cable) towards the Junction of Core and Cladding.

As shown above on RHS indicates that the core is divided in to many parts such as n_x , n_y , n_z and n_w . The Refractive Index of core is not constant and Refractive Index is divided in to n_x , n_y , n_z and n_w . Where $n_x > n_y > n_z > n_w$. The Refractive Index of core goes on gradually decreasing form the Axis of FOC(Fiber Optic Cable) towards the Junction of Core and Cladding.

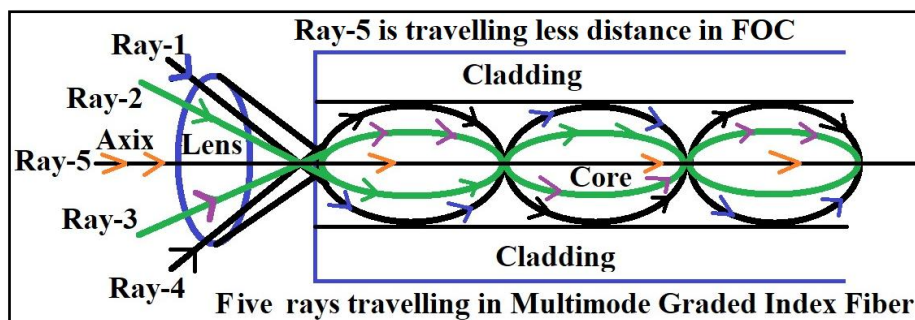
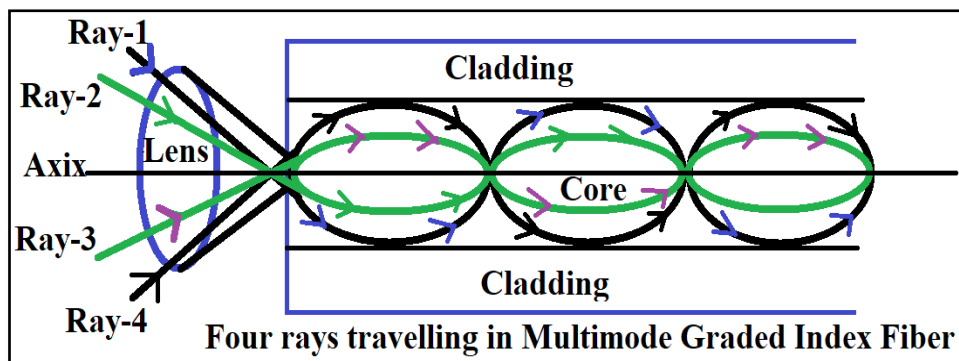

Profile of Refractive Index for Mono Mode Step Index, Multi-Mode Step Index and Multi-mode Graded Index FOC:

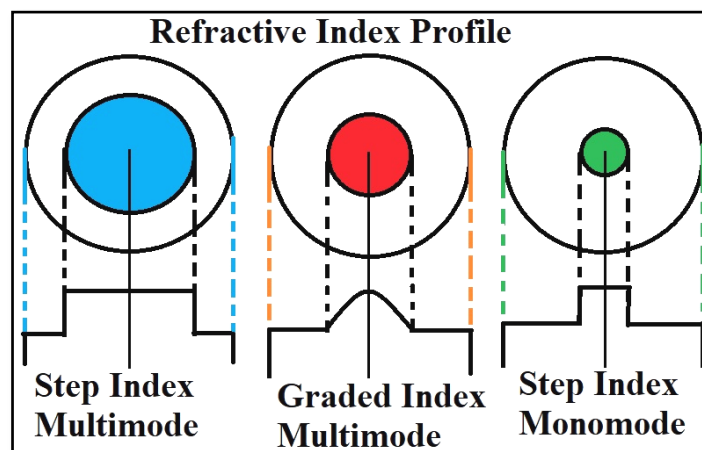

6. Index Profile Fibers: (Step Index and Graded Index Profile Fibers)

Index profile is the distribution of refractive index across the core and the cladding of a fiber. Some optical fiber has a *step index profile*, in which the core has one uniformly distributed refractive index and the cladding has a lower uniformly distributed refractive index. Other optical fiber has a *graded index profile*, in which refractive index varies gradually as a function of radial distance from the fiber center. Graded-index profiles include power-law index profiles and parabolic index profiles. The following figure shows some common types of index profiles for single mode and multimode fibers.

- **Step-Index Profile**

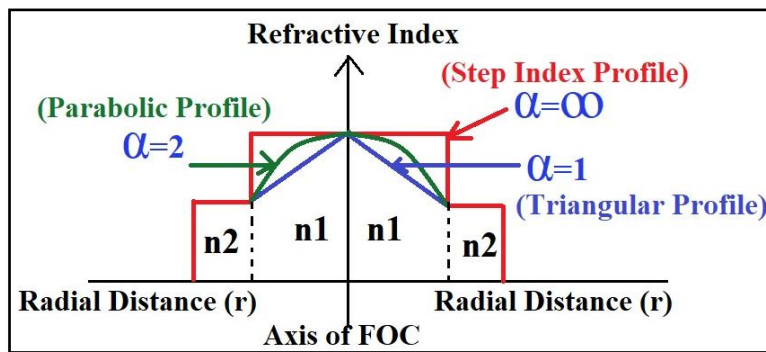

For an optical fiber, a **step-index profile** is a refractive index profile characterized by a uniform refractive index within the core and a sharp decrease in refractive index at the core-cladding interface so that the cladding is of a lower refractive index. The step-index profile corresponds to a power-law index profile with the profile parameter approaching infinity. The step-index profile is used in most single-mode fibers and some multimode fibers.

7. Meridional Rays and Skew Rays or Helical Rays: Meridional Ray propagates in one plane whereas skew rays or helical ray propagate in different plane. Skew rays propagate without passing through the center axis of the fiber.

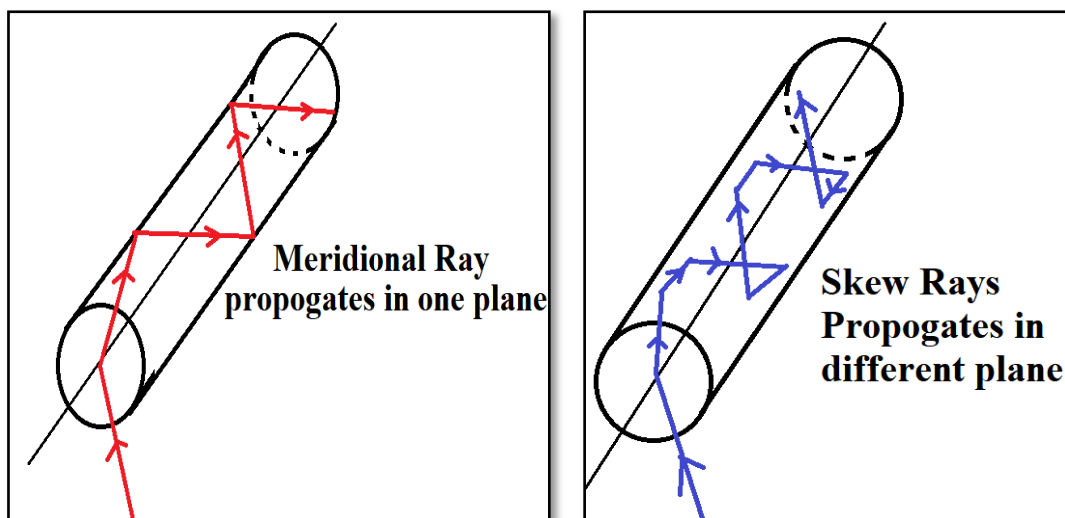

The acceptance angle for skew rays is larger than the acceptance angle of meridional rays. This condition explains why skew rays outnumber meridional rays. Skew rays are often used in the calculation of light acceptance in an optical fiber. The addition of skew rays increases the amount of light capacity of a fiber. In large NA fibers, the increase may be significant.

The addition of skew rays also increases the amount of loss in a fiber. Skew rays tend to propagate near the edge of the fiber core. Large portions of the number of skew rays that are trapped in the fiber core are considered to be **leaky rays**. Leaky rays are predicted to be totally reflected at the core-cladding boundary. However, these rays are partially refracted because of the curved nature of the fiber boundary. Mode theory is also used to describe this type of leaky ray loss.

8. Modes and Materials: Since optical fiber is a wave guide, light can propagate in a number of modes

- If a fiber is of large diameter, light entering at different angles will excite different modes while narrow fiber may only excite one mode.
- Multi mode propagation will cause dispersion, which results in the spreading of pulses and limits the usable bandwidth.
- Single-mode fiber has much less dispersion but is more expensive to produce. Its small size, together with the fact that its numerical aperture is smaller than that of multi-mode fiber, makes it more difficult to couple to light sources.

