

METHODOLOGY AND EXPERIMENTAL SETUP FOR MICROSTRIP PATCH ANTENNA

Authors

Dr. Vidyadhar S Melkeri
Assistant Professor
Department of Applied Electronics
Gulbarga University Kalaburagi
Karnataka, India.
vidaydharsm@gmail.com

Sunil G Jaganath
Assistant Professor
Sharnbasva University Kalaburagi
Karnataka, India.
gj.sunil@gmail.com

Rangayya Abkari
Associate Professor
Sharnbasva University Kalaburagi
Karnataka, India.
rangu2kiran@gmail.com

I. INTRODUCTION

In this chapter, the simulation software, measurement equipment used for measurement and fabrication technique of proposed microstrip antennas are discussed. The simulations of conventional square microstrip antenna and square microstrip antennas with different defected ground structures are obtained by using ANSYS-HFSS, High Frequency simulation software of version 13.0. The investigation of conventional square microstrip antenna and square microstrip antennas with different defected ground structures is carried out experimentally by using German make Rohde and Schwarz (R&S) Vector Network Analyzer (VNA) of ZVK model (10 MHz - 40 GHz) in the Microwave Electronics Research Laboratory (MERL), Department of Post Graduate Studies and Research in Applied Electronics, Gulbarga University, Kalaburagi-585106.

II. DETAILS OF VECTOR NETWORK ANALYZER (VNA)

The detailed S-parameters calculation of passive and active networks be able to measure with VNA, it consists of two-channel microwave receiver intended to handle the magnitude and phase of transmitted signal and reflected signal in the network. It matches the incident signal that departs the analyzer along with signal that is transmitted via test device. The results like return loss, VSWR. The impedance reported in this work is measured on VNA (Rohde & Schwarz, Germany, ZVK model 1127.8651, (10 MHz-40 GHz), The photographic image of VNA is revealed in Figure. 3.1. The logical variables utilized at the microwave frequencies remain as traveling waves than that of voltage and currents. The basic task of network analyzer is measurement of various S-parameters. These S-parameters are represented as shown in Figure. 1.

The general representations of S-parameters are S_{ij} . The subscripts i and j denote the use of ports. Usually j port is exited (input port) and i used for measuring output. Thus, S_{11}

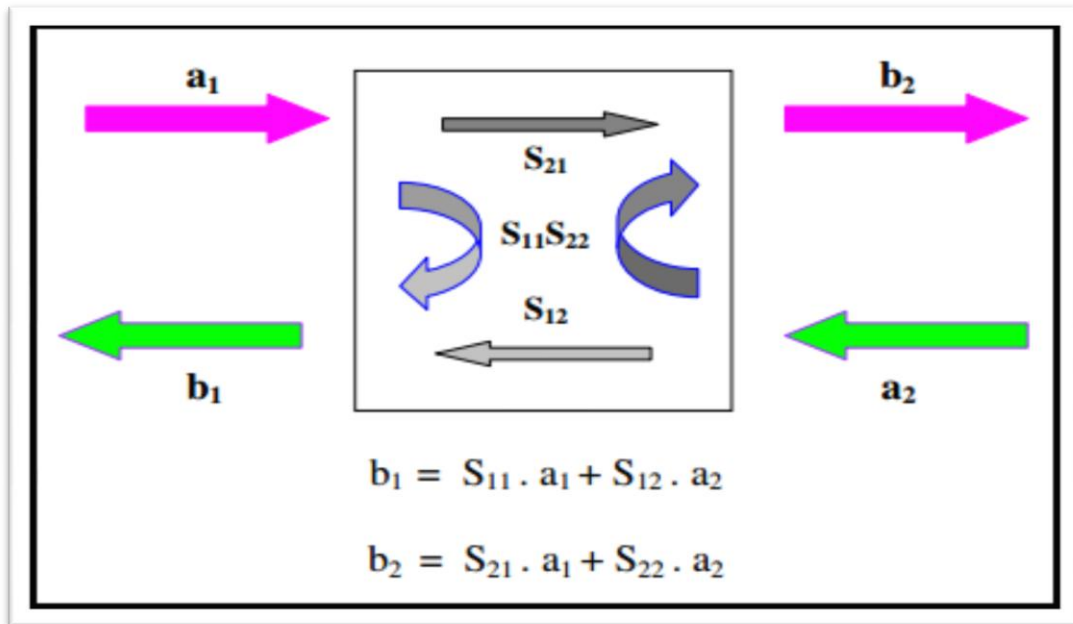

Figure 2: S-parameters

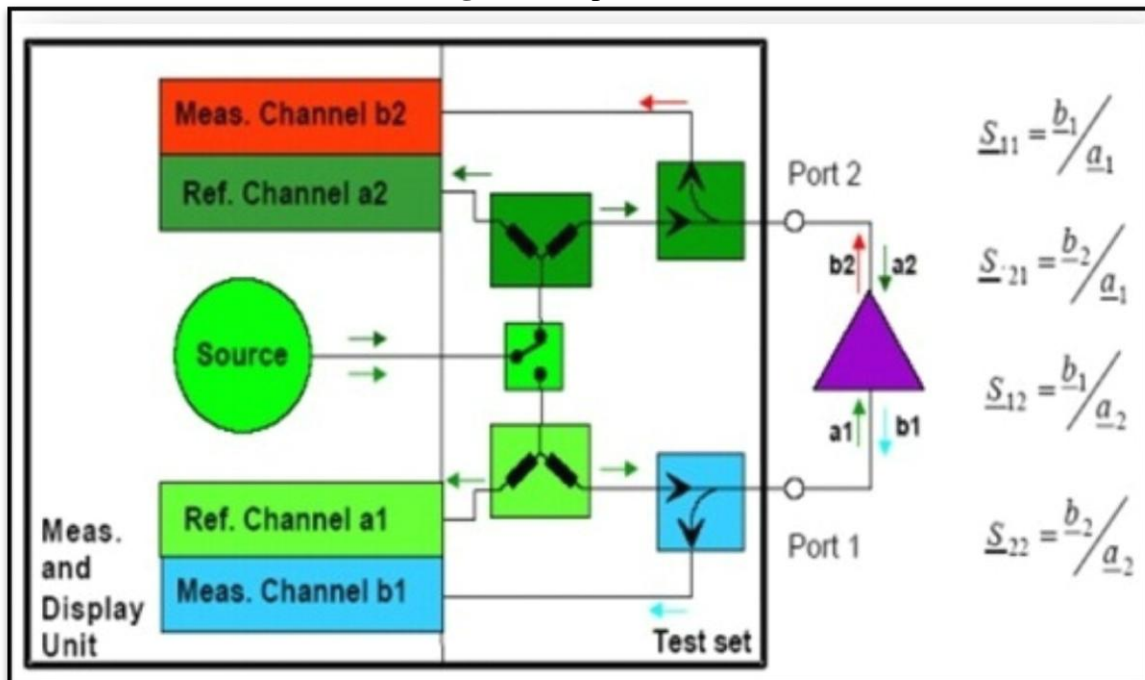

Figure 3: Principle operation of VNA (ZVK model)

- Basic Highlights: The general features of VNA, (ZVK model) are

Open to PC and Ethernet	Efficiency and Operation	Excellent Technical Data
Integrated Pentium PC	Large display with 4-Channel	High Speed

Link to Ethernet and IEC/IEEE bus control	External PC monitor control	Extraordinary sensitivity with Dynamic range
WINDOWS NT operation system	Subdivision of frequency along magnitude axis	High accuracy
PC- friendly formats	Numerous marker functions	Calibration Techniques
Assembly to Ethernet with FSE-B16	Subjective zooming	Wide frequency range
No external PC necessary- "Control of its own"	Subjective zooming	--
Quick and easy documentation	Operation via hard keys or mouse	---
Measurement and simulation in one instrument	Automatic two-port calibration Auto Cal (up to 8 GHz)	-

III. METHOD OF OPERATION OF VNA

The VNA of ZVK model works for the frequency range of 10 MHz to 40 GHz. The start and stop band has to be fixed before starting to take readings on VNA practically since it works for the wide range of frequency. The VNA is initially calibrated using calkit in four steps such as: Open, Short, Through and Match separately as per the procedure provided in the user manual.

The radio frequency (RF) source is typically arranged to sweep over particular bandwidth. A four-port reflectometer divides the incident, reflected and transmitted RF waves, a switch allows the network to be driven from either port 1 or port 2. Four dual-conversion channels convert these signals to 1000 KHz (adjustable) Intermediate frequency (IF) range, which are then detected and converted to digital form for extraction of data. An influential internal computer performs calculation and displays the magnitude reading and phase reading of the S- parameters, or additional quantities that can be derivative from the S-parameters, such as VSWR, return loss, group delay, impedance etc. A significant feature of VNA is the substantial improvement in accuracy made possible with error correcting software which is inbuilt. Errors caused by directional coupler mismatch, imperfect directivity, loss and variations in the frequency response of the analyzer system are accounted by using a twelve-form error model and a calibration procedure in the system. Another useful feature is the capability to determine the time domain response of the network by calculating the IFT of the frequency domain data obtained.

IV. STANDARD WAVEGUIDE HORN ANTENNA

The end air-d-out waveguide can be designated as horn antenna. The need of horn for creating a uniform phase setup with a greater aperture than the waveguide providing greater directivity. Horn antennas are fundamentally classified into rectangular horn and circular horn. The rectangular horn antenna includes exponentially tapered pyramidal horn, H-plane,

sectorial E-plane and pyramidal. The circular horns include exponentially tapered, conical, TEM bi conical and TE₁₀ bi conical. A rectangular horn has both E and H plane is known as pyramidal horn. A pyramidal horn is universally used standard antenna because, it shows minimum or no side lobes of E and H plane when compared to other microwave antennas.

- 1. Corrugated Horn Antenna:** The improved version of horn antenna with pyramidal structure is the corrugated (grooved) horn. It decreases the spurious radiations and provides good radiation in E and H planes. This antenna incorporates corrugations in its structure for better efficiency.
- 2. Power Meter:** The Boonton make 4220A model, power meter for measurement of transmitted power from VNA and received power at Antenna that is Under Test (AUT). The feature of this power meter is its accuracy, repeatability, wide frequency range, high speed operation, FND display and compatibility for other recording and display units. The technical specification of RF power meter 4220A model is given in Table 3.1.

V. TURN TABLE BASED RADIATION PATTERN MEASUREMENT SETUP

The turn table arrangement is used for measuring the radiation pattern of antenna under test, specially designed by Sophisticated Test and Instrumentation Center (STIC), Cochin University of Science and Technology, Cochin. The turn table has two units, positioner control system (S310C) and antenna positioner (S310P). The S310C is microcontroller-based turn table which works as standalone unit also can be controlled using computer. The S310C is fabricated to control the S310 series positioner which is stepper motor driven. The S310C will operate in two modes such as local and remote mode. This arrangement of turn table is as presented in Figure. 4 and Figure. 5 diagrammatic and photographic images respectively.

In this arrangement a benchmark pyramidal horn antenna which is a transmitting antenna and antenna under test, (AUT) receiving antenna are placed facing each other and then, maintaining the transmitting antenna fixed and rotating the receiving antenna around its axis to change the angle in paces of degrees in order to obtain the radiation pattern. The signal receiving system as revealed in Figure. 3.5 consists of S310P, S310C and AUT, crystal detector, amplifier, A/D converter and PC. The distance between transmitting antenna and receiving antenna placed at distance = $2D^2/\lambda$, where D is the wider dimension of pyramidal horn antenna where λ is the operating wavelength. Tx and Rx antenna are aligned properly for obtaining the maximum power on axis. The microwave power at the transmitting section is boosted for the required and desired frequency of proposed antenna which is under test to acquire the radiation pattern values.

Table 1.1: Technical specifications of RF power meter (Model 4220A, M/S Boonton Electronics Corp., New Jersey, USA)

Parameters	Specification
Frequency range	100 kHz to 100 GHz sensor dependent
Power range	Varying 70 dBm ~+ 44 dBm, sensor dependent

Power sensors	Matching with all Boonton diode and thermal sensors
Dynamic range	From 0 to 90 dB with sensor
Inputs	Sensor based front and rear panels with IEEE-488 connector as optional
Outputs	Outputs Front panel, 50 MHz, 0 dBm; BNC connector 9.09 kilo-ohm impedance, 0 to 13 volts into 1 mega-ohm (may be operated onto 1 kilo-ohm for 1V frequencies). Absolute DC accuracy is 3%.
Displays: Main data, dB CAL FACTOR, Analog	4-1/2-digit LED, 4-digit LED, Meter, reading proportional to main data display (frequencies = 10 dB; 5 dB in dBr)
Display units	W, mW, W, nW, dBm, dBr
Display resolution	0.01 dB or 4-1/2 digits (in Watts mode)
Ranging	Manual (7 ranges) or auto ranging
Filtering	Filter times to 20.00 seconds in 0.05 second increments
Zeroing	Automatic function; calculates, stores and upgrades with zero correction value to each range
Power reference: Frequency, Output, level, source impedance	50 MHz, 1.5%, 0 dBm, 50 1 ohm, <1.05.

In the local mode, the operator can directly enter the angular positions in degrees in order to position the turn table. The arrow keys provided over front panel of S310C is used to position the turn table manually. The AUT is associated with crystal detector across SMA connector. The output of crystal sensor is fed to the power meter to measure the received power at different angles.

In the remote operation, the S310C is regulated from a computer through the RS-232C interface. The amplifier in this case, amplifies the output of crystal detector. The amplified signal is fed to PC via its COM port. This analog signal is then digitized by A/D converter. The PC reads only digital data of A/D converter, which is proportional to the received power of AUT for different azimuth angles with respect to transmitting antenna.

VI. METHODS OF MEASUREMENTS OF ANTENNA PARAMETERS

The important parameters of antenna that are measured in this study are return loss, impedance bandwidth, VSWR, radiation pattern, smith chart and gain. The methods of measurement of these parameters are explained below.

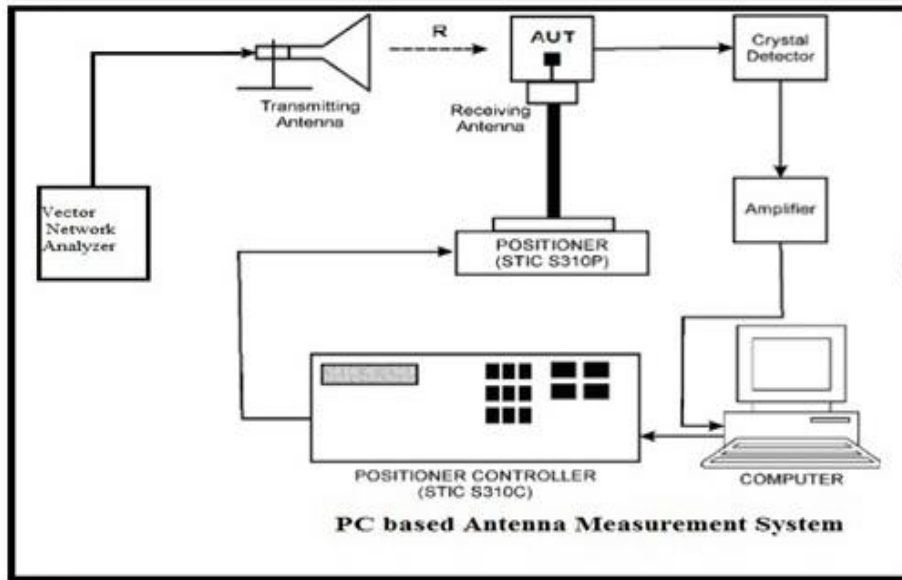

Figure.4: Diagrammatic Image of Turn Table and PC Based Radiation Pattern Measurement



Figure 5: Turn table and PC based radiation pattern measurement setup and photograph

- 1. Measurement of Return Loss and VSWR:** Return loss [RL] is the ratio of incident power to the reflected power at a point on the waveguide slotted section and is articulated in decibels (dB) The return loss (RL) specifies the power that is lost on load and doesn't not return back as a reflection to the source. Hence it is the parameter that indicates perfectness of matching related with transmitter and receiving antenna has taken place.

$$RL = 10 \log \left(\frac{P_i}{P_r} \right) = 10 \log \left(\frac{1}{|\Gamma|^2} \right) = 10 \log |\Gamma|^{-2} = -20 \log |\Gamma| \quad (1.1)$$

where,

Γ is the reflection co-efficient. The reflection co-efficient and Voltage Standing Wave Ratio (VSWR) are related to each other [8] [32].

$$VSWR = \frac{(1+|\Gamma|)}{(1-|\Gamma|)} \quad (1.2)$$

$$|\Gamma| = \frac{(VSWR-1)}{(VSWR+1)} \quad (1.3)$$

The ratio of max and min voltage of standing wave pattern which appear due to incident and reflected signal from the load is known as VSWR. Condition for perfect matching connecting the transmitter and the antenna is, $\Gamma = 0$ and $RL = \infty$, which indicates no power will be reflected back. Whereas when condition is $\Gamma = 1$ and $RL = 0$, which indicates that all instance of power is reflected giving no matching. The maximum value of VSWR acceptable for practical application is 2, this value is accepted because it corresponds to RL of -9.45 db.

- 2. Measurement of Impedance Bandwidth:** The series of frequencies over which antenna resonates perfectly is termed as bandwidth of an antenna. Since bandwidth of an antenna is function of impedance and hence commonly termed as impedance bandwidth. The useful bandwidth of an antenna can be limited by several conditions, such as impedance and gain. Basically, input impedance is the main factor that affects the usable bandwidth of small antennas. The input impedance of a small antenna is can vary rapidly with frequency. This limits frequency range above which the antenna will be matched to its feed line. The impedance bandwidth is generally specified in RL or VSWR. Typical matching requirements are $VSWR \leq 2$ or RL -10dB. Impedance bandwidth is calculated by [17].

$$Impedance\ Bandwidth = \frac{(VSWR-1)}{Q\sqrt{VSWR}} \quad (1.4)$$

$$Impedance\ bandwidth\ (\%) = \left[\frac{f_2-f_1}{f_c} \right] \times 100\% \quad (1.5)$$

Where,

Q = Quality factor

f_1 and f_2 = lower and upper cut-off frequencies of the operating bands respectively when its return loss reaches -10 dB.

f_c = Center frequency between f_1 and f_2 .

- 3. Input Impedance Measurement:** The input impedance of an antenna is described as `the impedance given by an antenna at input terminals else the ratio of the voltage to the current at terminals or the ratio of a suitable components in electric to magnetic fields at the point. Hence input impedance of the antenna is provided as [32],

$$Z_{in} = (R_{in} + X_{in}) \quad (1.6)$$

where, Z_{in} implies antenna input impedance at the terminals, R_{in} implies antenna input resistance at terminals and X_{in} implies antenna input reactance at the terminals. The reactance function of the input impedance stands for the power collected in the near field

of antenna. The resistive part R_{in} of input impedance contains of two different components, the radiation resistance (RR) and loss resistance (RL). The power related with the radiation resistance is the power in reality radiated by the antenna, though power dissipated in resistance is gone as heat in the antenna that one due to dielectric otherwise conducting losses.

For an ideal case an input impedance is 50. The efficient design and utilization of an antenna differs on its input impedance. In an incompatible system, the amount of mismatch determines the amount of incident power or available power, which is reflected from the input terminals back into the line. The degree of divergence is dependent on the antenna input impedance and the distinctive impedance of the line. The input impedance is usually a function of frequency, geometry, methods of excitation and immediacy to its surrounding objects.

- 4. Measurement of Radiation Pattern:** Antenna radiation pattern is described as “a mathematical definition or graphical representation properties of an antenna as function of space coordinates. The radiation pattern shows a graphical notation of the comparative field strength of transmitted or received at antenna. The patterns are acquired at resonating frequency, one polarization, alone with one in plane cut. The patterns are typically donated in polar or rectangular coordinates in dB scale. For most of the microwave antennas, it is generally necessary for obtaining radiation pattern in horizontal (H) and vertical (E) plane. However, co-polar with cross-polar measurement are generally considered for study of directive radiation characteristics of the antennas.

The PC based measurement system for radiation pattern which is presented in Figure. 3.5. is used to measure the co-polar and cross-polar radiation patterns of proposed antennas. During the measurement of co-polar pattern, the regular horn antenna is connected at the end of transmitted and AUT is kept on antenna positioner S310P at a distance R from the transmitting antenna. A microwave power meter is connected to AUT for measuring the received power by AUT. The AUT is rotated from -900 to +900 in azimuth plane with a step angle of 50^0 . The power received at each angle is recorded. The graph is plotted relating standardized power v/s azimuth angle which gives co-polar radiation pattern of AUT. During the measurement of cross- polar radiation pattern of AUT, the receiver antenna is turned by an angle of 900 with respect to AUT. The received power measured at each angle in this case is normalized with respect to co-polar power received at AUT.

- 5. Half Power Beam Width (HPBW) Measurement:** One of the important parameters which can be known from the radiation is HPBW. [32] It shows the sharpness of the beam in the corresponding plane. The HPBW is the angular width (in degree) of the principal lobe in middle of the two directions, of which the radiated or received power is one-half the extreme value of the beam. However, the term beam width by itself is usually to describe the -3dB beam width.
- 6. Gain Measurement:** The figure of merit that defines the performance of any radiator is its gain. There are various schemes applied to measure gain. The two general methods applied to calculate the gain of an electromagnetic radiator are absolute-gain and gain-transfer measurements. The absolute-gain method applies a calibrated antenna that is selected as

standard for gain measurements which doesn't need to have prior knowledge of gain of the antenna. A gain-transfer method is applied in conjunction with standard to determine the total gain of the AUT. The two antennas that are most widely used and universally accepted as standards are the resonant $\lambda/2$ dipole and the pyramidal horn antenna. Both possess linear polarizations. The gain G of antenna will be written as, [32].

$$G = \frac{\text{Area of spherical radiator}}{\text{Area of actual radiator}} \quad (1.7)$$

In this gain measurement, if two identical horn antennas are selected, the equation for given is given by [32]

$$G = \frac{4\pi R}{\lambda_0} \sqrt{\frac{P_r}{P_t}} \quad (1.8)$$

Where

R is the distance involving two antennas, P_r is Rx power, P_t is the Tx power and λ_0 is free space wavelength. In case of two dissimilar antennas, if the HPBWs are known, the gain of the AUT is calculated by using the equation [32].

$$G = \left(\frac{30000}{\theta_E \theta_H} \right)_{dB} \quad (1.9)$$

Where

θ_H and θ_E are the half power beam widths of test antenna in E and H-plane respectively.

In this discussion, the gain of AUT is measured by absolute-gain method. Using these experimental data, the gain G in dB is obtained using the formula

$$(G)_{dB} = 10 \log \left(\frac{P_r}{P_t} \right) - (G_t)_{dB} - 20 \log \left(\frac{\lambda_0}{4\pi R} \right)_{dB} \quad dB \quad (1.10)$$

Where

G_t is the gain of the horn antenna and is given by,

$$G_t = 10 \log \left(\frac{2\pi ab}{\lambda^2} \right) \quad dB \quad (1.11)$$

Where a and b are the broader and shorter dimensions of the horn antenna respectively.

VII. HIGH FREQUENCY STRUCTURE SIMULATOR (HFSS) SOFTWARE

HFSS-IE is a full-wave, Integral Equation solver that computes the "currents" on the surfaces of objects in the model mutually finite conducting and lossy dielectric things are allowed. HFSS-IE is designed for large problems.

Simulation is important step, which saves money and time before fabrication with provided accuracy. It is an intermediate step between design and fabrication. To use a simulator, it is very important to test your knowledge with it. Simulating an antenna structure and then measuring it can improve the design. There may be some difference involving

simulated and measured results. One of the error sources is the accuracy of fabrication and it is another domain. Thus, to remove the doubt one must measure the actual dimensions after the fabrication process and re-simulate the structure with this new dimension. The result will be your experience and knowledge with the simulator. Any antenna structure is considered by its matching and far-field characteristics within it. The technique of simulation used to calculate full 3D electromagnetic field within a structure is grounded on the finite element method (FEM). Although its implementation is mainly transparent, a general consideration of the method is beneficial in making the most applicable use of ANSOFT HFSS. This delivers an overview of the FEM and its realization in ANSOFT HFSS. It also defines how S parameters can be computed since the simulated EM fields and how it can be converted to “Nodal” based pseudo-S-parameters as defined in circuit theory for analysis. The Figure 3.6 gives a basic outline of how the design process ends up with a product by analyzing its characteristics in the software before going for the fabrication. The fabricated and the simulated results match most of the time with minor errors, which can be later compensated by fine tuning of the simulated design.

- 1. Methods of analysis in HFSS :** HFSS is comprised of four technologies which makes it efficient solver, GUI, Mesh, Solver, HPC, for generating an electromagnetic fields results, ANSOFT HFSS employs the FEM. In general, the FEM divides the complete problem space divided into thousands of minor regions and signifies the field in each substitute region with a local variable. ANSOFT HFSS, the geometric structure is automatically separated into a large quantity of tetrahedra, where an individual tetrahedron is basically four-sided pyramid. This collected works of tetrahedral is referred as finite element mesh.



Figure.6: Basic outline of simulation software

HFSS provides programmed, accurate, and efficient results to overcome above challenges, creating it the ultimate tool of high-quality for antenna simulation. Basic functioning and characterization of antenna can be investigated in HFSS. Important post-processing features of ability to overlay the 3D far-field pattern on the antenna geometry provides the designer precious insight and direct correlation linking the antenna and the resulting analysis. HFSS also deals with electric and magnetic field picturing both in near-

field and far-field. This insight allows the engineer to regulate the portions of the geometry relevant to the antennas performance. Combined with Optometrists, HFSS also permits engineers to parametrically stretch design variations to inspect the antennas design area leveraging such method of optimization techniques such as Quasi Newton, Pattern Search, Sequential Non-linear Programming (SNLP), Mixed Integer SNLP, and genetic algorithms. This high-level of analysis that provide design sensitivities and data on overall geometric performance and manufacturing produces reliability.

2. **Automatic Adaptive Meshing:** The importance of a vector field quantity at coordinates of inside each tetrahedron is incorporated from the vertices of tetrahedron. At every vertex, ANSOFT HFSS stores the sections of the field that is tangential to the three edges of the tetrahedron structure. In addition, it stores the component of vector field at midpoint of designated edges that is lateral to a face and normal to the edge. The field within each tetrahedron is interpolated by nodal values. By signifying field quantities, the system will be able to transform Maxwell's equations into Matrix equations. An important feature of HFSS is automatic adaptive mesh refinement which produces a precise solution based on the physics of electromagnetics. This automated meshing method departs the focus on the antenna design. This automation and definite accurateness differentiate HFSS from all other EM simulators, which typically require manual user controls to ensure that the generated mesh is suitable and accurate for simulation. Without the correct mesh, the results from such simulators can be erroneous. But with automatic adaptive meshing, HFSS lets the physics define the mesh and not the other way around and guarantees accurate results. The meshing algorithm refines mesh automatically throughout the geometry; it iteratively adds mesh elements in areas where a finer mesh is needed due to the localized electromagnetic field behavior.
3. **Basic Operations :** Various interpolation techniques that can be used to interpolate field values from nodal values,
 - A 1st order tangential based elementary function incorporates field values of both nodal values at vertices and edges. The 1st order tangential essentials have approximately 20 unknowns per tetrahedron.
 - In 0th order-based function uses nodal values at vertices only assuming field varies linearly inside every tetrahedron. There are approximately six unknow per tetrahedron.

The accurateness of the solution based on how small each of an individual element. To generate an accurate description of a field magnitude, each element must reside in a region which is small enough for the field to be sufficiently interpolated from nodal values. Though, generating a field solution involves inserting a matrix with approximately as many elements as there are tetrahedral nodes. For meshes with a huge number of elements, such an inversion compels a significant amount of calculating power and memory. Therefore, it is appropriate to use a mesh that is fine enough to acquire an accurate field clarification but not so fine that it overthrows the available computer memory and handling power, to produce an optimal mesh, ANSOFT HFSS customs an iterative procedure in which the mesh is spontaneously refined in critical areas. Firstly, it generates a solution and then it improves the mesh in areas of high error concentration and

produces a new solution. Though, when designated parameters converge to within an anticipated limit, the system discontinuities out of the loop.

VIII. THE HFSS INTERFACE

The main page of HFSS software interface is displayed in Figure 7, which exemplifies the main modules of the GUI. They are recapitulated as follows:

1. **3D Modeler** it is that area where geometry module is created. This consists of the model area with grid. The history tree manuscripts the actions performed in the model view area, providing alternate way of selecting things.
2. **Project Manager along with Project Tree** window shows details of all open HFSS projects modules. Each project eventually includes a geometric model, its boundary conditions, material selection, field solution method used and post processing data.
3. **Properties Window** this window consists of two different tabs. The command tab displays displaying list of commands used. The attribute tab displays info about the material and display properties of an object selected.
4. **Progress Window** this window works when simulation process is going on and used to know the progress of simulation.
5. **Message Manager** used for knowing the result analysis messages and process related messages.

To compute the S-matrix related with a structure, following steps need to done:

- Distributes the structure into a finite element.
- Calculates the modes on every port that are sustained by a transmission line having similar cross-section.
- Calculates the full 3D EM field pattern within the structure, by supposing that every mode is excited one by one.
- Calculates a generalized S-matrix from data of reflection and transmission occurred.

The final solution is an S-matrix that lets the magnitude readings of transmitted and reflected signals to be calculated directly from input signals, reducing the full 3D behavior of structure to set of high frequency circuit parameter.

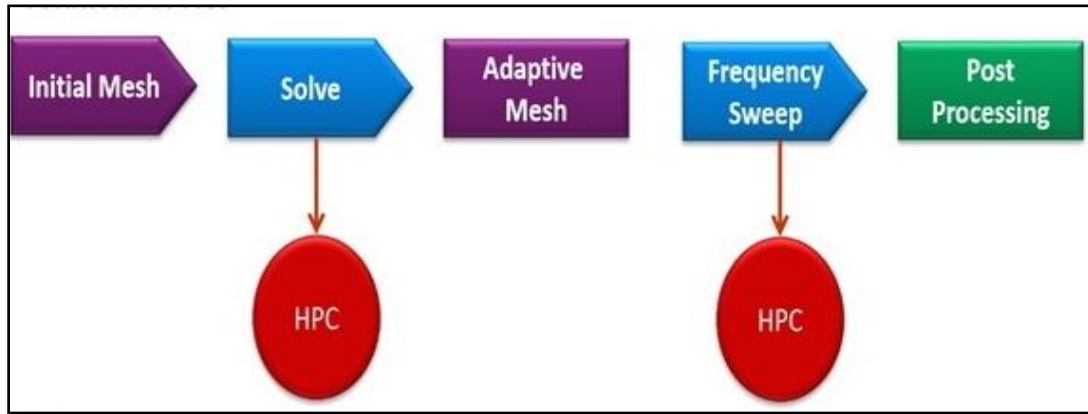

Figure 8: Solution process of HFSS simulation

- Single frequency solution
- Fast frequency sweep
- Discrete frequency sweep
- Interpolating frequency sweep

7. Antenna Simulation Technologies in HFSS: HFSS offers the following simulation techniques and tools dependent upon the kind of problem we want to solve and in Table 1.2 provides the various software modules present in ANSOFT ANSYS HFSS:

- Finite Element Method technology (Incorporated with HFSS)
- Integral Equations technology (Incorporated with HFSS-IE)
- Physical Optics technology (Incorporated with HFSS-IE)
- FEM Transient technology (Incorporated with HFSS-TR)

Table 1.2: Software Modules of HFSS

Module	Function
Executive module	Performs every executive function required
3-D modeler version	Provides elaborated interface for extracting geometric models
Material management	Provides option of interface for allocating materials to objects
3-Dimensional boundary	Provides elaborated interface for allocating boundaries and sources elements
Mesh 3D	Allows to generates the preliminary mesh and refines prevailing meshes. Also provides complete interface for manually recalibrating the mesh

Wave	Determines the excitation field pattern at each port
ABC 3D	Engages in computes the required full 3Dimnesional solution within the structure
General Solver	Usually inverts the matrix that is associated with the FEM
Eigen Solver	Efficient in calculating Real or Complex structural Eigen modes
Post Processor	Generally, provide useful interface for investigating the data obtained during the solution process. Three Post Process are available

8. SQMSA Modeling in ANSOFT HFSS

The first step is to draw the geometric model of the antenna that is to be analyzed. The following step is of selecting material characteristics to each 3-D object in the geometric model. Boundaries are then defined for the structures, such as radiation, perfect-E, perfect-H or finite conductivity. A port or a voltage source needs to be defined to excite the structure. This is done as a part of the boundary definitions. Once the structure is completely modeled, the solution is set up. This includes specifying the type of solution to be performed, the frequency at which the adaptive mesh refinement takes place and the convergence criteria. The problem is then solved for the fields associated with the model.

- Design tutorial for 2.4 GHz microstrip edge feed patch antenna using substrate thickness 1.6 mm and $\epsilon_r = 4.2$ the return loss must be less than -10 dB at 2.4 GHz
The design flow of the work is as presented in the Figure 9 which is followed to obtain the complete design of patch antenna.



Figure 9: Design flow process of HFSS

The geometry of the design is given in the Figure 10, the values need for the geometry is calculated from the formulas given in the design consideration of square

microstrip patch antenna, conventionally the rectangular patch antenna is considered and for taking square patch into consideration the length of rectangular patch is dropped and width is considered as the length. The Figure 11 shows the basic view of HFSS after design completion of SQMSA.

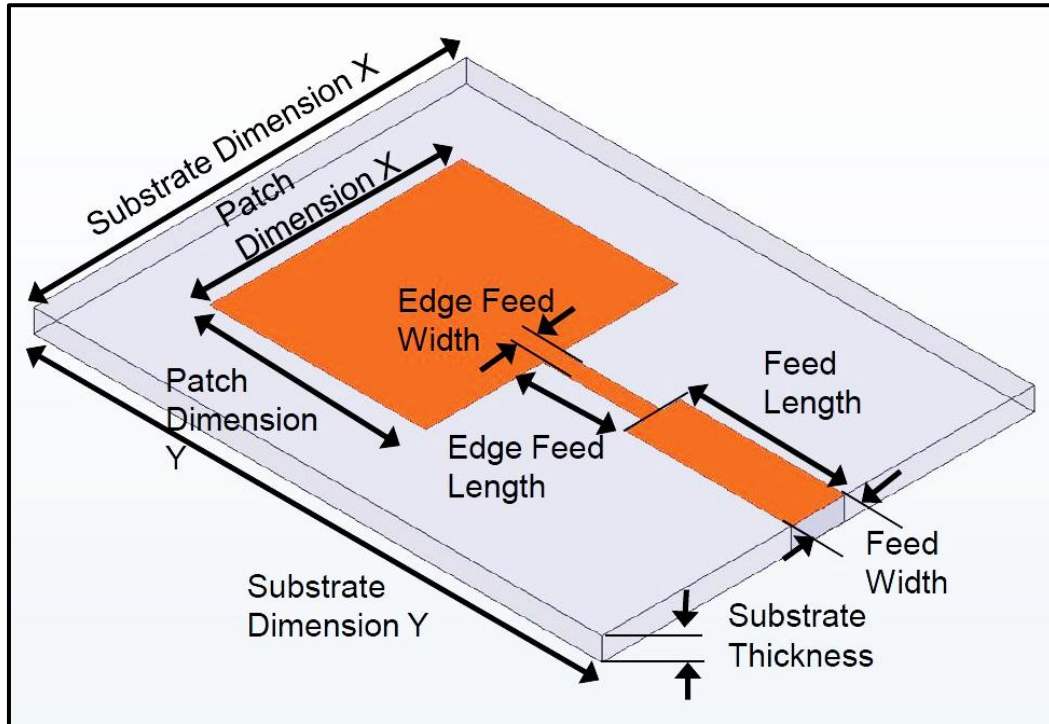

Figure 10: Geometry of Edge feed microstrip patch antenna

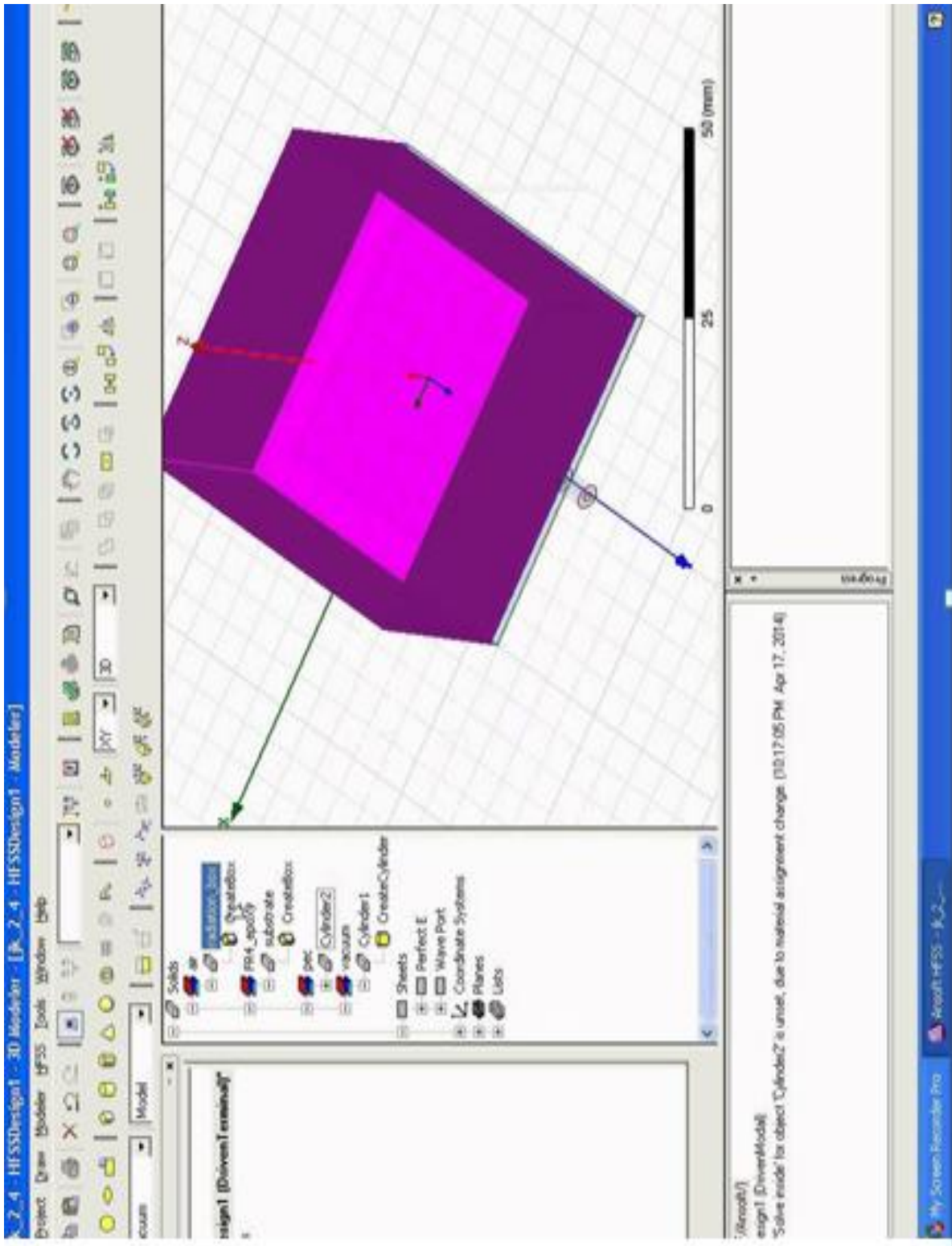

Figure 11: Basic view of design structure on HFSS

9. **Simulation results of HFSS:** Figure 3.12 shows the various simulation results, following results can be obtained from the simulation software like return loss, radiation pattern, impedance bandwidth etc.

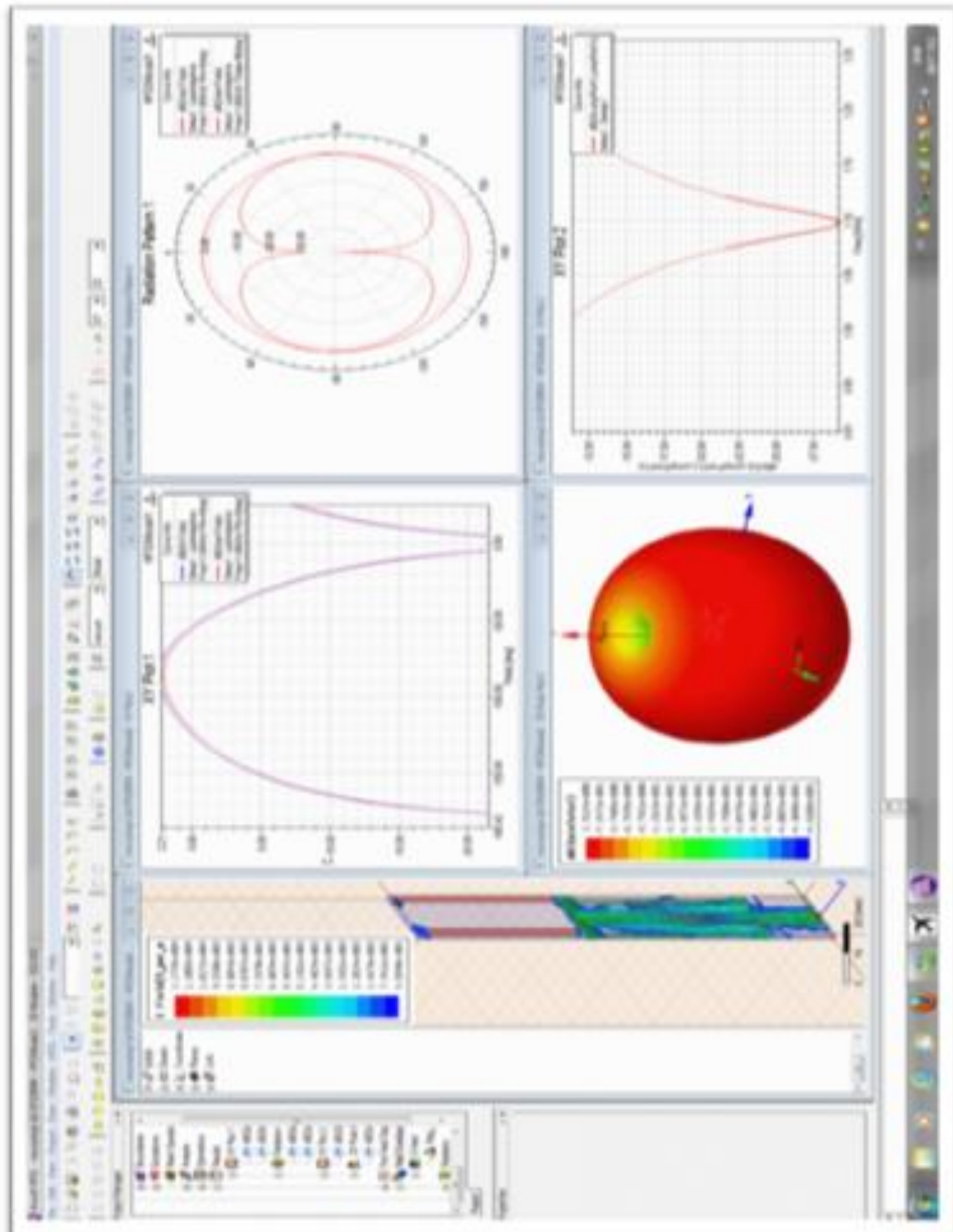

Figure 12: Simulation results of HFSS

10. Antenna Fabrication: The antennas used in this research work are fabricated by photolithographic development technology. This is a method used for micro fabrication which needs a series of step to embed the thin metal on the substrate selected. The most important step of this process is chemical etching or removing by which the unwanted region of metallic layer is removed so that desired pattern is obtained. The separation of wanted and unwanted region by the application of photoresist. Depending upon the antenna type and design in this case its biplanar since single Substrate is used in the work and the etching is done on both side of the substrate. Regarding the antenna design the choice of the substrate material plays important role.

11. Selection of Substrate Material: After completing first stage by designing microstrip antenna second stage is selecting the suitable substrate. There are different types of substrate obtainable in market that delivers considerable flexibility in the selection of a substrate for particular applications. Substrate is an important feature in the design of an MSA. Important characters of the dielectric substrate include.

- The frequency dependency of this dielectric constant produces "material dispersion" because of which wave velocity is frequency-dependent.
- The surface smoothness and flatness
- Material loss tangent, which defines the dielectric loss
- The cost and manufacturability
- The thermal extension and conductivity.
- The copper surface thickness.
- The dimensional steadiness with time.
- The surface sticking together of conductor coatings.
- The ease of manufacturability (cutting, shaping, and drilling).
- The porosity (for high vacuum applications)

In order to provide support and protection for the patch elements, the dielectric substrate must be strong and able to tolerate high temperature during soldering procedure and has high resistant with regard to chemicals that will be used in fabrication process. In addition, the dielectric constant along with loss tangent are also functions of frequency. This problem though, can be condensed or avoided by using an appropriately low permittivity substrate.

There are abundant substrates used for the designing of microstrip antennas, with their dielectric constants typically ranges from $2.2 \leq \epsilon_r \leq 12$. The low dielectric constant ϵ_r is about 2.2 to 3.3, the medium around 4.3 to 9 and the high approximately above 9.3 to 12. The drawbacks are that it is less efficient and has relatively smaller bandwidths. For that reason, which rises design trade-off among the size of antenna and better performance in antenna. By increasing the substrate thickness will surge the bandwidth performance at the expenditure of antenna efficiency because the waves are trapped in the substrate wall causes surface wave excitation. The ideal substrate didn't exist, depending upon the application choice of the substrate material also varies.

The dielectric constant, thickness or height of the material and loss tangent are the important factors under consideration for fabrication. This method is more suitable for low

or medium dielectric constant and low loss dielectrics. The FR4 modified epoxy substrate with dielectric constant $\epsilon_r = 4.4$, loss tangent $\tan \delta = 0.002$, and height = 1.6mm are mostly used for the work described in this thesis.

12. Photolithography: Photolithography or optical lithography is a technique used in microfabrication for patterning different geometrical shapes from the photo mask to the surface of the substrate. Initially, select the appropriate substrate material and then the geometry of the desired structure is drawn using a high precision computer-aided design (CAD) software. Then the CAD drawing of the antenna is obtained on a butter paper or a transparent sheet with a high resolution printer. The substrate with one side of copper, which is known as copper clad, is cleaned with metal cloth and acetone to remove the imperfections and impurities.

Any of the imperfections or disparity in the surface will shift the frequency from the desired response or from the predicted values. Then a thin layer of photo resist is extended over the copper clad by a high speed spinner. Here a negative photo resist is employed for the photolithographic process. Then the photo mask is perfectly aligned on the photo resist coated clad and exposed to ultra violet rays. Exceptional care has to be taken so that no impurities are present between the copper clad and the photo resist coating. In the photo resist layer, the exposed portions to the UV rays harden, but the unexposed portions remain unchanged and can be removed by rinsing cautiously with a developer solution. The unnecessary copper can be removed from the clad by dipping the clad in a ferric chloride (FeCl_3) solution. The stabilized photo resist is removed by using an acetone solution. The various steps essential for the photolithography are shown in Figure.13.

13. Fabrication of MSA: After designing the MSA, the next important step is the fabrication of the MSA. The process of fabrication requires a sophisticated and extraordinary dimensional accuracy to be maintained during the fabrication process of antennas. Hence, the dimensions of the design are efficiently maintained by drawing the structures designed using AUTO-CAD 2013. This file is used for laser printing with precision on the substrate and placing of the radiating element on one side and the ground plane on the other side of the substrate using the photolithographic process as explained above. For better accuracy, the process was carried out at Cosmic Engineering Enterprise, ECIL-X Road, Hyderabad. Later, the power is fed into these fabricated antennas through an SMA connector and measured experimentally using a VNA.

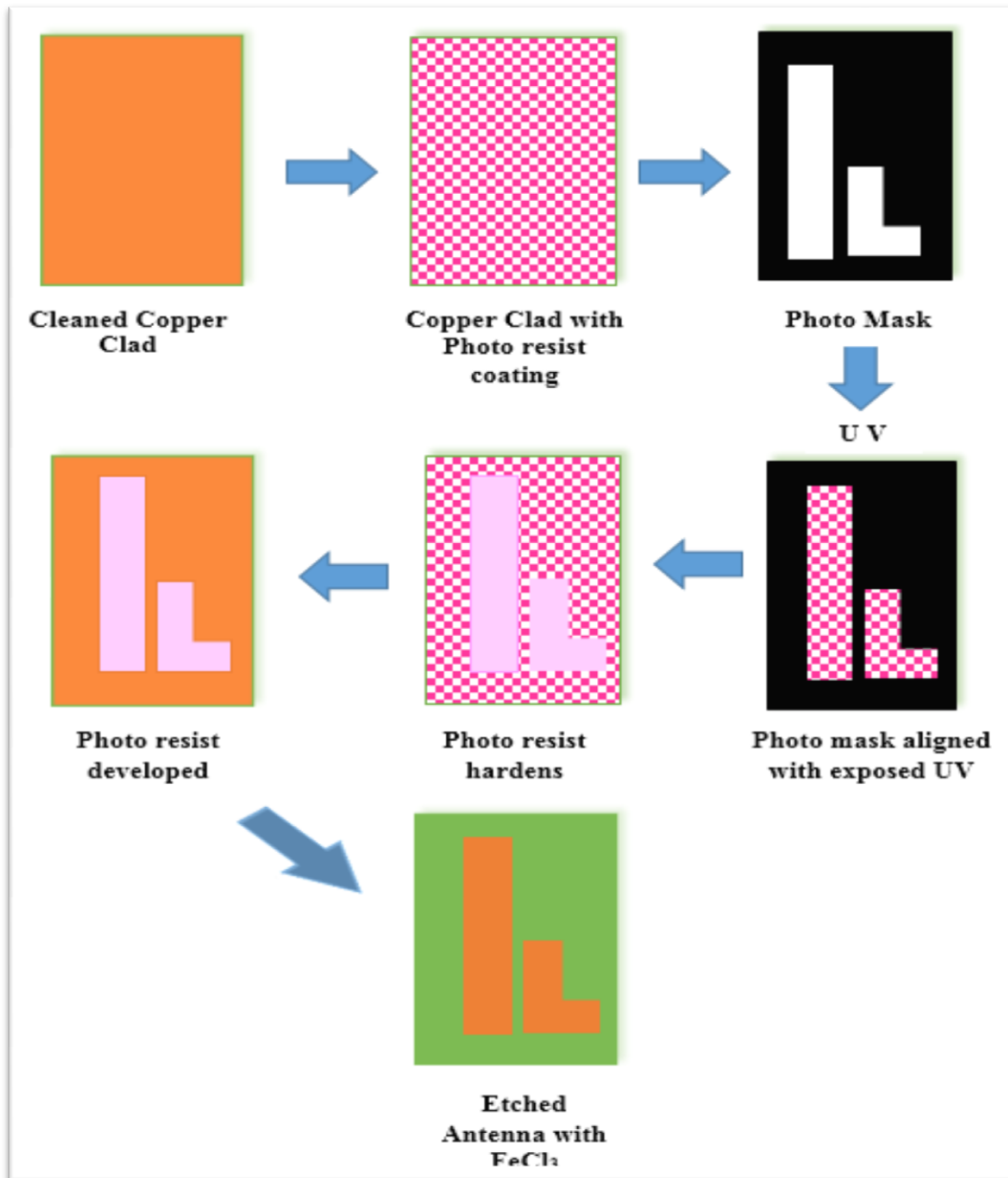

Figure 13: Steps involved in the Photolithographic Process

In this chapter we have understood the various methodologies involved in the antenna design process from software simulation to the fabrication of antenna. The experimental results and discussion of proposed antenna of both 2.4 GHz and 5 GHz conventional antenna is represented in succeeding chapter, i.e., Chapter 4 contains of two parts in which experimental results of conventional antenna is discussed and method of implementation of DGS on ground plane is given in detail.