

LAMINAR AND TURBULENT FLOW

Abstract

There are numerous approaches to visually represent flow patterns, whether they involve laminar or turbulent flows. A highly compelling method to illustrate these distinctions involves observing the disturbances occurring on the surface of a water stream emerging from a cylindrical tube. Captured through flash photography, these images vividly showcase the characteristics of water flow within pipes. They effectively highlight the disparity between turbulent and laminar flow, providing an accessible means to collect data for the analysis of conditions that give rise to both types of flow.

While there exist research articles centered around turbulence measurements that utilize advanced equipment, they do not employ the perturbations occurring on the free surface of the flowing liquid as a means to demonstrate or quantify turbulence.

Keywords: Types of flow, Turbulence, Velocity distribution, Losses in pipes, Power dissipation.

Authors

Dr. P. Sreenivasulu

Professor
Department of Mechanical Engineering
Gokula Krshna College of Engineering
Sullurpet Gokula Krshna College of
Engineering
Sullurpet, Andhra Pradesh, India.

Dr. M. Paul Daniel

Professor
Department of Mechanical Engineering
Narayana Engineering
College(Autonomous)
Gudur, Andhra Pradesh, India.

Daggubati Sunil

Assistant Professor
Department of Mechanical Engineering
Narayana Engineering
College(Autonomous)
Gudur, Andhra Pradesh, India.

D. Raveendra

Assistant Professor
Department of Mechanical Engineering
Narayana Engineering College
(Autonomous)
Gudur, Andhra Pradesh, India.

I. INTRODUCTION

A conduit has a closed boundary where the flow is confined to be wholly internal. It is in this sense, the conduit flow is also referred as a confined flow or internal flow. Though a conduit may be of any shape, circular shapes are common and equations are primarily stated for circular cross sections.

Computation of fluid flow in conduits was one of the earliest problems of engineers and in modern technology it is encountered in many branches of engineering. Civil. Mechanical. Aeronautical, chemical. etc. Consequently considerable advances. Both in the theoretical and in the experimental, work have been made.

Any attempt in understanding conduit flow shall have to be towards the aim of computing the pressure losses in the flow. Field problems like pipeline systems, ventilating and air conditioning systems, chemical plant systems require the pressure drop characteristics for their designs. The importance of accurate knowledge of pressure losses is enhanced because of large, sophisticated modern conduit systems. Even marginal reductions in pressure losses in such cases are known to yield enormous savings,

II. REYNOLDS EXPERIMENT

Two states of flow have been introduced under Sec.5.4 the orderly laminar flow and the complex turbulent flow. These two states of flow are distinctly different warranting independent analysis. Qualitative description of the state of flow is then not sufficient. But one needs to understand deeper to know when a flow would remain laminar or turbulent.

Osborne Reynolds. An English scientist in 1883 was interested in obtaining a quantitative criterion to determine whether a flow in a pipe is laminar or turbulent. He constructed simple equipment shown schematically in Fig.1 and performed experiments under well controlled conditions. He arranged to introduce a fine thread of colored dye into water flowing from a large tank into a fairly long glass cylinder; the speed of the water is controlled through throttling the valve at the end of the glass tube. At small velocities he found that the dye

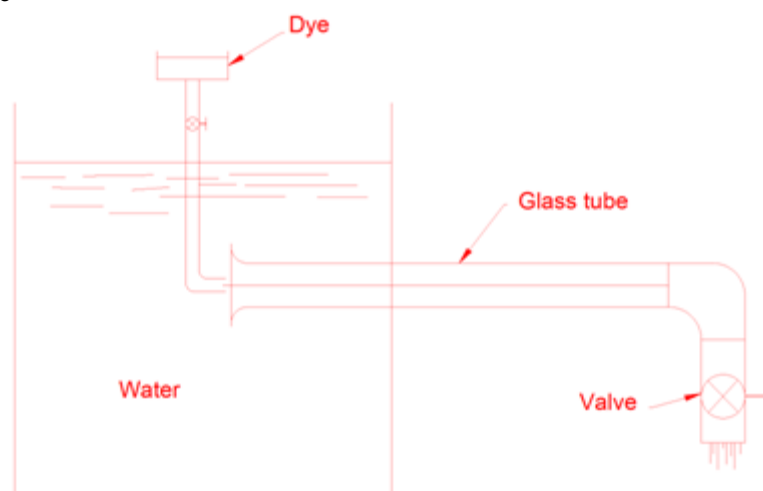

Figure 1: Reynolds apparatus.

Filament remained a thin, straight streak parallel to the direction of flow indicating that the water particles moved in streamlines or in *laminas*. There was no mixing with the adjacent laminas, thus it demonstrates clearly the laminar state of flow. When the velocity of flow was increased gradually, the dye filament began to waver at some stage (see Fig. 2). When the velocity was further increased the dye streak broke and diffused to spread across the entire cross section of the tube in a disorderly fashion. This indicates a chaotic motion of the fluid particles mixing crosswise which establishes turbulent flow.

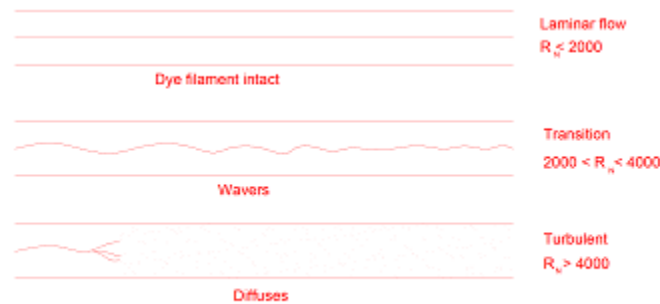

Figure 2

Reynolds intuitively thought that the stability of the flowing particles should be influenced by the physical quantities, velocity, diameter, density and viscosity. The first three he argued to have like tendency because increasing values of velocity, diameter and density would help to bring in instability. On the contrary, increasing viscosity would only try to damp out any disturbances that are introduced. Accordingly he thought that a quantity

$$\frac{\text{Velocity} \times \text{diameter} \times \text{density}}{\text{Viscosity}} = \frac{Vd\rho}{\mu}$$

Might be a criterion. He further observed that this group is a mere dimension-less number which again guided his thinking that all natural phenomena should be influenced only by the nature of physical quantities and not by their magnitudes. Hence natural phenomena must be functions of dimensionless group of physical quantities. This dimensionless number, subsequently named after Reynolds, has been found to acquire an important status in the analysis of fluid flow. Being dimensionless, it must be valid for any fluid, liquid or gas.

It was later understood on a physical level that the Reynolds number represents a straightforward ratio of inertial forces to viscous forces. That is Reynolds Number (Re) It is defined as the ratio of the inertia force to the viscous force.

Inertia force (F_i) = mass \times acceleration

$$\begin{aligned} &= \rho \times \text{Volume} \times \frac{\text{Velocity}}{\text{time}} \\ &= \rho \times \frac{\text{Volume}}{\text{time}} \times \text{Velocity} \\ &= \rho \times AV \times V \quad [\because \text{Volume per second} = \text{area} \times \text{velocity} = AV] \\ &= \rho AV^2 \end{aligned}$$

Viscous force (F_v) = shear stress \times area = $\tau \times A$

$$= \left(\mu \frac{du}{dy} \right) \times A$$

$$= \mu \frac{V}{L} \times A \quad \left(\because \frac{du}{dy} = \frac{V}{L} \right)$$

$$\therefore \text{Reynolds number, } Re = \frac{F_i}{F_v} = \frac{\rho AV^2}{\mu \times \frac{V}{L} \times A} = \frac{\rho VL}{\mu}$$

i.e. $Re = \frac{\rho VL}{\mu} = \frac{VL}{\mu/\rho} = \frac{VL}{\nu} \quad \left(\because \nu = \frac{\mu}{\rho} \right)$

For pipe flow (where the linear dimension is taken as diameter, d),

$$Re = \frac{Vd}{\nu} = \frac{Vd\rho}{\mu} \text{ ----- (1)}$$

For flow through circular pipes, it has generally been accepted now that if RN is less than 2000 laminar flow is sustained. Low values of RN indicate the relative influence of viscous forces over the inertia forces; the inertial tendencies of the disturbing forces are suppressed by the viscous shear to establish a laminar flow field. When RN is greater than 4000 the flow becomes fully turbulent where viscous forces are no longer capable of damping out the increased inertial strength of the disturbances. Between Reynolds number of 2000 and 4000 a region of uncertain behavior called *transition* prevails. As changes cannot be abrupt in nature the transition from one type of flow to another alternates back and forth between laminar and turbulent.

Critical reynolds number

III.LAMINAR FLOW OR VISCOUS FLUID FLOW

1. Flow of Viscous Fluid in Circular pipes – Hagen Poiseuille Law

Hagen- poiseuille theory is based on the following *assumptions*:

- The fluid follows Newton’s law of viscosity.
- There is no slip of fluid particles at the boundary (*I.e.i* the fluid particles adjacent to the pipe will have zero velocity).

Fig. 3 shows a horizontal circular pipe of radius R , having laminar flow of fluid through it. Consider a small concentric cylinder (fluid element) of radius r and length dx as a free body.

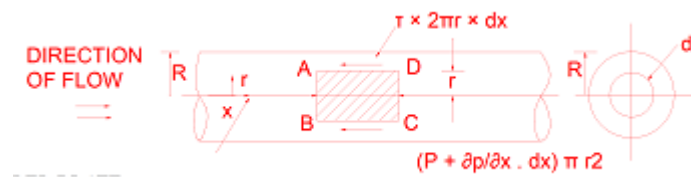

Figure 3: Viscous/laminar flow through a circular pipe.

If τ is the shear stress, the shear force F is given by

$$F = \tau \times 2\pi r \times dx$$

Let P be the intensity of pressure at left end and the intensity of pressure at the right end be

$$\left[P + \frac{\partial p}{\partial x} \cdot dx \right]$$

Thus the forces acting on the fluid element are:

- The shear force, $\tau \times 2\pi r \times dx$ on the surface of fluid element.
- The pressure force, P The shear force, $P \times 2\pi r^2$ on the left end.

- The pressure force, $[P + \frac{\partial p}{\partial x} \cdot dx] \pi r^2$ on the right end.
 For steady flow, the net force on the cylinder must be zero.
 $\therefore [P \times \pi r^2 - [P + \frac{\partial p}{\partial x} \cdot dx] \cdot \pi r^2] - \tau \times 2\pi r \times dx = 0$
 Or, $\frac{\partial p}{\partial x} \cdot dx \times \pi r^2 - \tau \times 2\pi r \times dx = 0$
 Or, $\tau = -\frac{\partial p}{\partial x} \cdot \frac{r}{2}$ ----- (7.2)

Eqn. (2) Indicates that fluid flow will happen solely when a pressure gradient exists in the flow direction, and the negative sign signifies a decrease in pressure along the flow path.

Eqn. (2) suggests that the distribution of shear stress across a section is linear, as depicted in fig 4 (a). Its absolute value becomes zero at the pipe's center ($r = 0$) and reaches its peak value at the pipe wall.

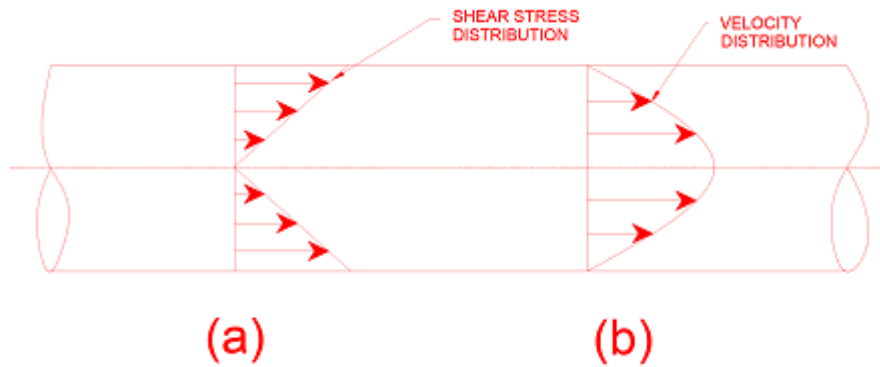

Figure 4: Shear stress and velocity distribution across a section.

Velocity Distribution: To obtain the velocity distribution across a section, the value of shear stress $\tau = \mu \cdot \frac{du}{dy}$ is substituted in equation (7.2)

In this equation, the distance y is measured from the edge. The relationship between radial distance r and distance y can be expressed as follows
 $Y = R - r$ or $dy = - dr$

$$\therefore \tau = \mu \frac{du}{-dr} = -\mu \cdot \frac{du}{dr} \dots\dots(7.3)$$

When we compare the two τ values from equations (7.2) and (7.3), we obtain the following

$$-\mu \frac{du}{dr} = -\frac{\partial p}{\partial x} \cdot \frac{r}{2}$$

Or,

$$du = \frac{1}{2\mu} \left[\frac{\partial p}{\partial x} \right] r \cdot dr$$

Integrating the above equation w.r.t 'r' we get

$$u = \frac{1}{4\mu} \cdot \frac{\partial p}{\partial x} r^2 + C$$

Where C is the constant of integration and its value is obtained from the boundary condition

$$r = R, u = 0$$

$$0 = \frac{1}{4\mu} \cdot \frac{\partial p}{\partial x} R^2 + C \quad \text{or,} \quad C = -\frac{1}{4\mu} \cdot \frac{\partial p}{\partial x} \cdot R^2$$

Substituting this value of C in eqn. (7.2), we get

$$u = \frac{1}{4\mu} \cdot \frac{\partial p}{\partial x} r^2 - \frac{1}{4\mu} \cdot \frac{\partial p}{\partial x} \cdot R^2$$

$$u = -\frac{1}{4\mu} \cdot \frac{\partial p}{\partial x} \cdot (R^2 - r^2) \dots\dots\dots(7.4)$$

Eq (7.4) shows that the velocity distribution is a parabola as shown in fig 7.4. The maximum velocity occurs at the centre of i.e at $r = 0$ and is given by

$$u_{max} = -\frac{1}{4\mu} \cdot \frac{\partial p}{\partial x} \cdot R^2 \quad \text{-----} (7.5)$$

From eqns. (7.4) and (7.5), we have

$$u = u_{max} \left[1 - \left(\frac{r}{R}\right)^2 \right] \quad \text{-----} (7.6)$$

Eqn. (7.6) This equation is widely employed to describe the velocity distribution in laminar flow through pipes. One can utilize this equation to determine the discharge in the following manner:

$$dQ = u \times 2\pi r \times dr$$

$$= u_{max} \left[1 - \left(\frac{r}{R}\right)^2 \right] 2\pi r \cdot dr$$

Total discharge, $Q = \int dQ$

$$= \int_0^R u_{max} \left[1 - \left(\frac{r}{R}\right)^2 \right] 2\pi r \cdot dr$$

$$= 2\pi r \cdot dr \int_0^R \left[r - \frac{r^3}{R^2} \right] dr$$

$$= 2\pi \cdot u_{max} \left[\frac{r^2}{2} - \frac{r^4}{4R^2} \right] = 2\pi \cdot u_{max} \left[\frac{R^2}{2} - \frac{R^4}{4R^2} \right]$$

Average velocity of flow, $\bar{u} = \frac{Q}{A} = \frac{\frac{\pi}{2} u_{max} R^2}{\pi R^2} = \frac{u_{max}}{2} \quad \text{-----} (7.7)$

Eqn. (7.7) Indicates that the mean velocity is equal to half of the maximum velocity..

By replacing the value of u_{max} from equation (7.6), we obtain the following.

$$\bar{u} = -\frac{1}{8\mu} \cdot \frac{\partial p}{\partial x} \cdot R^2$$

Or, $\partial p = \frac{8\mu \bar{u}}{R^2} \cdot \partial x$

The pressure contrast between sections 1 and 2, located at distances x_1 and x_2 respectively (see Fig. 5)

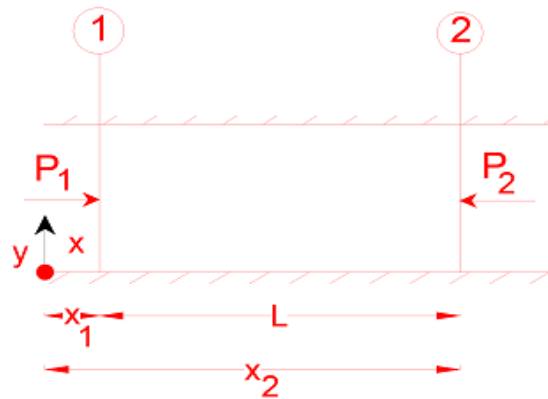

Fig 5. is given by

$$\int_{p_1}^{p_2} \partial p = \frac{8\mu\bar{u}}{R^2} \cdot \int_{x_1}^{x_2} \partial x$$

Or,

$$(P_1 - P_2) = \frac{8\mu\bar{u}}{R^2} (x_2 - x_1) = \frac{8\mu\bar{u}L}{R^2} \{ \because x_2 - x_1 = L$$

from fig 7.5}

$$= \frac{8\mu\bar{u}L}{(D/2)^2} \{ \because R=D/2 \}$$

Or,

$$(P_1 - P_2) = \frac{32\mu\bar{u}L}{D^2}, \text{ where } P_1 - P_2 \text{ is the drop of pressure.}$$

pressure.

$$\therefore \text{Loss of pressure head} = \frac{P_1 - P_2}{\rho g}$$

$$\therefore \frac{P_1 - P_2}{\rho g} = hf = \frac{32\mu\bar{u}L}{\rho g D^2} \dots\dots(7.8)$$

Where, D is the diameter of the pipe, and L is the length
Eqn. (7.8) is known as the **Hagen-poiseuille equation**.

Problems

Problem 1 A crude oil of viscosity 0.9 poise and relative density 0.8 is flowing through a horizontal circular pipe of diameter 80 mm and of length 15m. Calculate the difference of pressure at the two ends of the pipe, if 50 kg of the oil is collected in a tank in 15 seconds.

Solution. Given : $\mu = 0.9 \text{ poise} = \frac{0.9}{10} = 0.09 \text{ Ns/m}^2$

Relative density = 0.8

$\therefore \rho_0$, or density, = $0.8 \times 1000 = 800 \text{ kg/m}^3$

Dia. of pipe, $D = 80 \text{ mm} = 0.08 \text{ m}$

$L = 15 \text{ m}$

Mass of oil collected, $M = 50 \text{ kg}$

In time, $t = 15 \text{ seconds}$

Calculate difference of pressure or $(p_1 - p_2)$.

The difference of pressure $(p_1 - p_2)$ for viscous or laminar flow is given by

$$p_1 - p_2 = \frac{32\mu\bar{u}L}{D^2}, \text{ where } \bar{u} = \text{average velocity} = \frac{Q}{\text{Area}}$$

Now, mass of oil/sec = $\frac{50}{15} \text{ kg/s}$

$$= \rho_0 \times Q = 800 \times Q \quad (\because \rho_0 = 800)$$

$$\begin{aligned} \therefore \quad & \frac{50}{15} = 800 \times Q \\ \therefore \quad & Q = \frac{50}{15} \times \frac{1}{800} = 4.16 \times 10^{-3} \text{ m}^3/\text{s} \\ \therefore \quad & \bar{u} = \frac{Q}{\text{Area}} = \frac{4.16 \times 10^{-3}}{\frac{\pi}{4} D^2} = \frac{4.16 \times 10^{-3}}{\frac{\pi}{4} (0.08)^2} = 0.829 \text{ m/s.} \end{aligned}$$

For laminar or viscous flow, the Reynolds number (R_e) is less than 2000. Let us calculate the Reynolds number for this problem.

Reynolds number, $R_e^* = \frac{\rho V D}{\mu}$
where $\rho = \rho_0 = 800, V = \bar{u} = 0.829, D = 0.08 \text{ m}, \mu = 0.09$

$$\therefore R_e = 800 \times \frac{0.829 \times 0.08}{0.09} = 589.46$$

As Reynolds number is less than 2000, the flow is laminar.

$$\begin{aligned} \therefore \quad p_1 - p_2 &= \frac{32 \mu \bar{u} L}{D^2} = \frac{32 \times 0.09 \times 0.829 \times 15}{(0.08)^2} \text{ N/m}^2 \\ &= 559 \text{ N/m}^2 = 0.5595 \text{ N/m}^2. \text{ Ans.} \end{aligned}$$

Problem 2 Laminar flow is observed within a pipe with a 100 mm diameter, exhibiting a maximum velocity of 2 m/s. Determine the mean velocity, along with the corresponding radius. Additionally, compute the The speed at a point 3 cm away from the pipe's inner wall.

Solution. Given : Dia. Of pipe, $D = 100 \text{ mm} = 0.1 \text{ m}$

$$U_{\max} = 2 \text{ m/s}$$

Find

- Mean velocity, \bar{u}
- Radius at which \bar{u} occurs
- Velocity at 4 cm from the wall.
- **Mean velocity, \bar{u}**

Ratio of $\frac{U_{\max}}{\bar{u}} = 2.0$ or $\frac{2}{\bar{u}} = 2.0 \quad \therefore \bar{u} = \frac{2}{2.0} = 1 \text{ m/s. Ans.}$

- **Radius at which \bar{u} occurs**

The velocity, u , at any radius ' r ' is given by (7.4)

$$u = -\frac{1}{4\mu} \frac{\partial p}{\partial x} [R^2 - r^2] = -\frac{1}{4\mu} \frac{\partial p}{\partial x} R^2 \left[1 - \frac{r^2}{R^2} \right]$$

But from equation (7.5) U_{\max} is given by

$$U_{\max} = -\frac{1}{4\mu} \frac{\partial p}{\partial x} R^2 \quad \therefore u = U_{\max} \left[1 - \left(\frac{r^2}{R^2} \right)^2 \right]$$

Now the radius r at which $u = \bar{u} = 1 \text{ m/s}$

$$\begin{aligned} \therefore \quad 1 &= 2 \left[1 - \left(\frac{r}{D/2} \right)^2 \right] \\ &= 2 \left[1 - \left(\frac{r}{0.1/2} \right)^2 \right] = 2 \left[1 - \left(\frac{r}{0.1} \right)^2 \right] \end{aligned}$$

$$\therefore \quad \frac{1}{2} = 1 - \left(\frac{r}{0.1} \right)^2$$

$$\therefore \quad \left(\frac{r}{0.1} \right)^2 = 1 - \frac{1}{2} = 1 - \frac{1}{2} = \frac{1}{2}$$

$$\begin{aligned} \therefore \frac{r}{0.1} &= \sqrt{\frac{1}{2}} = \sqrt{0.5} \\ \therefore r &= 0.05 \times \sqrt{.5} = 0.05 \times .353 = 0.03535\text{m} \\ &= 35.35 \text{ mm. Ans.} \end{aligned}$$

Velocity at a distance of 3 cm from the wall.

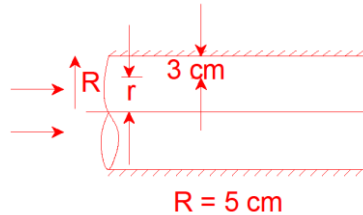

Fig 6

$$r = 5 - 3 = 2 \text{ cm} = 0.02 \text{ m}$$

\therefore The speed at a specific radial position = 0.02m
or 3 cm The distance from the pipe wall provides the following equation for velocity (1)

$$\begin{aligned} &= 2 \left[1 - \left(\frac{r}{R} \right)^2 \right] = 2 \left[1 - \left(\frac{0.02}{0.05} \right)^2 \right] \\ &= 2 [1.0 - 0.16] = 2 \times 0.84 = 1.68 \text{ m/s. Ans.} \end{aligned}$$

Problem 3 A fluid of viscosity 0.5 N s/m^2 and specific gravity 1.2 is flowing through a circular pipe of diameter 100 mm . The maximum shear stress at the pipe wall is given as 147.15 N/m^2 , find (a) the pressure gradient (b) the average velocity and (c) Reynold number of the flow.

Solution. Given :

$$\begin{aligned} \mu &= 0.5 \frac{\text{Ns}}{\text{m}^2} \\ \text{Sp. gr.} &= 1.2 \\ \therefore \text{Density} &= 1.2 \times 1000 = 1200 \text{ kg/m}^3 \\ \text{Dia. of pipe,} &D = 100 \text{ mm} = 0.1 \text{ m} \\ \text{Shear stress,} &\tau_0 = 147.15 \text{ N/m}^2 \end{aligned}$$

Find (i) Pressure gradient, $\frac{dp}{dx}$
(ii) Average velocity, \bar{u}
(iii) Reynold number, R_e

- **Pressure gradient, $\frac{dp}{dx}$**
- The maximum shear stress $(\tau_0) = -\frac{\partial p}{\partial x} \frac{R}{2}$ or $147.15 = -\frac{\partial p}{\partial x} \times \frac{D}{4} = -\frac{\partial p}{\partial x} \times \frac{0.1}{4}$
 $\therefore \frac{\partial p}{\partial x} = -\frac{147.15 \times 4}{0.1} = -5886 \text{ N/m}^2 \text{ per m}$
 \therefore Pressure Gradient = $-5886 \text{ N/m}^2 \text{ per m. Ans.}$

(ii) Average velocity, \bar{u}

$$\bar{u} = \frac{1}{2} U_{max} = \frac{1}{2} \left[-\frac{1}{4\mu} \frac{\partial p}{\partial x} R^2 \right] \quad \left\{ \because \right.$$

$$U_{max} = -18\mu \frac{\partial p}{\partial x} R^2$$

$$= \frac{1}{8\mu} \left(-\frac{\partial p}{\partial x} \right) R^2$$

$$= \frac{1}{8 \times 0.5} \times (5886) \times (.05)^2 \quad \left\{ \because R = \right.$$

$$D = 0.12 = .05$$

$$= 3.678 \text{ m/s}$$

• Reynold number, R_e

$$R^2 = \frac{\bar{u} \times D}{\nu} = \frac{\bar{u} \times D}{\frac{\mu}{\rho}} = \frac{\rho \times \bar{u} \times D}{\mu}$$

$$= 1200 \times \frac{3.678 \times 0.1}{0.5} = 882.72. \text{ Ans.}$$

2. Flow of Viscous Fluid Between Two Parallel Plates

Case-1: One plate is in motion while the other remains still, illustrating the concept of Couette flow

Let's analyze laminar flow between two parallel flat plates separated by a distance 'b.' In this setup, one plate remains stationary while the other moves at a constant velocity 'U,' as illustrated in Figure 7. We will concentrate on a small rectangular fluid element with dimensions 'dx' in length, 'dy' in thickness, and unit width. We'll treat this fluid element as a free body (as shown in Figure 7) and examine the forces it encounters

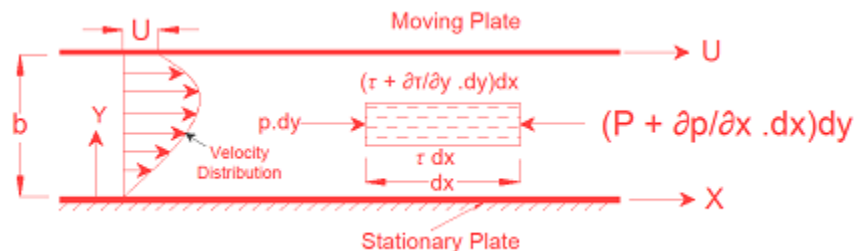

Figure 7: Couette Flow

- The pressure force on the left side, denoted as $p \cdot dy$
- The force due to pressure at the right end, expressed as $[P + (\partial p / \partial x) \cdot dx] \cdot dy$
- The shear force on the lower surface, represented as $\tau \cdot dx$
- The shear force, $[\tau + \frac{\partial \tau}{\partial y} \cdot dy] \cdot dx$ on the upper surface.

For steady and uniform flow, there is no acceleration and hence the resultant force in the direction of flow is zero.

$$\therefore p \cdot dy - [P + \frac{\partial p}{\partial x} \cdot dx] \cdot dy - \tau \cdot dx + [\tau + \frac{\partial \tau}{\partial y} \cdot dy] \cdot dx = 0$$

$$\text{Or,} \quad -\frac{\partial p}{\partial x} \cdot dx \cdot dy + \frac{\partial \tau}{\partial y} \cdot dy \cdot dx = 0$$

Upon division by the volume of the element dx.dy, the result is

$$\frac{\partial p}{\partial x} = \frac{\partial \tau}{\partial y} \quad \dots\dots(9)$$

Eqn. (7.9) shows the interdependence of shear and pressure gradients and is applicable for laminar as well as turbulent flow. According to the pressure gradient, in the direction of flow, is equal to the shear gradient across the flow.

According to Newton's law of viscosity for laminar flow the shear stress, $\tau = \mu \cdot \frac{\partial u}{\partial y}$. Substituting for τ in eqn. (7.9), we get

$$\frac{\partial p}{\partial x} = \mu \cdot \frac{\partial^2 u}{\partial y^2}$$

Since $\frac{\partial p}{\partial x}$ is independent of y, integrating the above equation twice w.r.t. y gives

$$u = \frac{1}{2\mu} \cdot \frac{\partial p}{\partial x} y^2 + C1 y + C2 \quad \dots\dots(7.10)$$

Where, C1 and C2 are the constants of integration to be evaluated from the known boundary conditions. In the present case the boundary conditions are:

At $y = 0, u = 0$, and at $y = b, u = U$

$$\therefore C2 = 0, \quad \text{and} \quad C1 = \frac{U}{b} - \frac{1}{2\mu} \left(\frac{\partial p}{\partial x} \right) b$$

Consequently, when we insert the values of C1 and C2 into equation (7.10), we arrive at the subsequent equation, which characterizes the velocity distribution in generalized Couette fluid motion.,

$$u = (U / b) * y - \frac{1}{2\mu} \cdot \frac{\partial p}{\partial x} (by - y^2) \quad \dots\dots(7.11)$$

Equation (7.11) Suggests that both the velocity 'U' and the spatial pressure gradient ($\partial p/\partial x$) play roles in shaping the velocity profile in Couette flow. However, it's important to highlight that the pressure gradient ($\partial p/\partial x$) in this context can take on either a positive or negative value. In a particular scenario where ($\partial p/\partial x$) equals zero, indicating the absence of a pressure gradient along the flow direction, we witness the velocity profile described by $u = U * (y/b)$. This linear velocity distribution represents a specific case referred to as simple (or plain) Couette flow or simple shear flow

We can determine the discharge per unit width (q) through the following calculation

$$q = \int_0^b u \cdot dy = \int_0^b \left[\frac{U}{b} y - \frac{1}{2\mu} \cdot \frac{\partial p}{\partial x} (by - y^2) \right] dy$$

$$= U \cdot \frac{b}{2} - \frac{b^3}{12\mu} \cdot \frac{\partial p}{\partial x} \quad \dots\dots(7.12)$$

The application of Newton's law of viscosity enables us to establish the shear stress distribution across any given section,

$$\tau = \mu \cdot \frac{\partial u}{\partial y} = \mu \left[\frac{U}{b} - \frac{1}{2\mu} \cdot \frac{\partial p}{\partial x} (b - 2y) \right]$$

$$= \mu \cdot \frac{U}{b} - \frac{1}{2} \cdot \frac{\partial p}{\partial x} (b - 2y) \quad \dots\dots(7.13)$$

The flow previously described, involving a viscous fluid moving between two plates—one stationary and the other in motion—is commonly termed generalized Couette flow..

Case-2: Both Plates at Rest: In this situation, it is also essential to calculate the shear stress distribution, the velocity distribution across a particular section, the ratio of maximum velocity to average velocity, and the difference in pressure head for a given length of parallel plates.

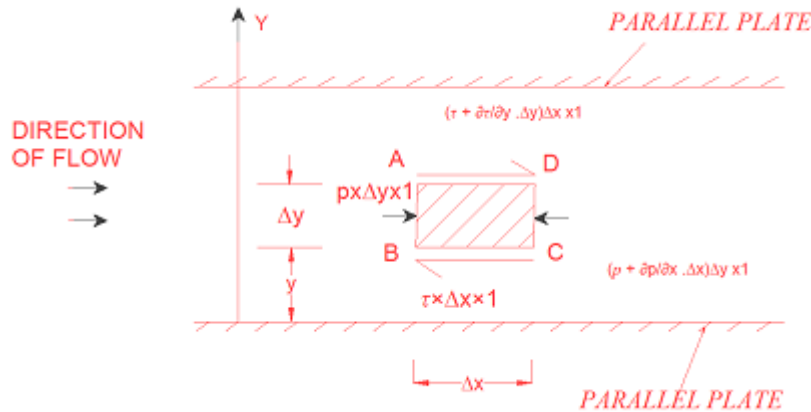

Figure 8: Flow between stationary plates

Consider two parallel fixed plates kept at a distance ‘b’ apart as shown in Fig. 8. A viscous fluid is flowing between these two plates from left to right. Consider a fluid element of length Δx and thickness Δy at a distance y from the lower fixed plate. If p is the intensity of pressure on the face AB of the fluid element then intensity of pressure on the face CD will be $(p + \frac{\partial p}{\partial x} \Delta x)$. Let τ is the shear stress acting on the face BC then the shear stress on the face AD will be $(\tau + \frac{\partial \tau}{\partial y} \Delta y)$. If the width of the element in the direction perpendicular to the paper is unity then the force acting on the fluid element are:

- The pressure force, $p \times \Delta y \times 1$ on face AB.
- The pressure force, $(p + \frac{\partial p}{\partial x} \Delta x) \Delta y \times 1$ on face CD.
- The shear force, $\tau \times \Delta x \times 1$ on face BC.
- The shear force, $(\tau + \frac{\partial \tau}{\partial y} \Delta y) \Delta x \times 1$ on face AD.

For steady and uniform flow, there is no acceleration and hence the resultant force in the direction flow is zero.

$$\therefore p \Delta y \times 1 - (p + \frac{\partial p}{\partial x} \Delta x) \Delta y \times 1 - \tau \Delta x \times 1 + (\tau + \frac{\partial \tau}{\partial y} \Delta y) \Delta x \times 1 = 0$$

$$\text{Or } -\frac{\partial p}{\partial x} \Delta x \Delta y + \frac{\partial \tau}{\partial y} \Delta y \Delta x = 0$$

$$\text{Dividing by } \Delta x \Delta y, \text{ we get } -\frac{\partial p}{\partial x} + \frac{\partial \tau}{\partial y} = 0 \text{ or } \frac{\partial p}{\partial x} = \frac{\partial \tau}{\partial y} \quad \text{-----(7.14)}$$

Velocity Distribution To determine the velocity distribution across a cross-section, we insert the shear stress value $\tau = \mu \frac{dy}{du}$ from Newton's law of viscosity for laminar flow into the equation. (9.6).

$$\begin{aligned} \therefore \quad \frac{\partial p}{\partial x} &= \frac{\partial}{\partial y} \left(\mu \frac{\partial u}{\partial y} \right) = \mu \frac{\partial^2 u}{\partial y^2} \\ \therefore \quad \frac{\partial^2 u}{\partial y^2} &= \frac{1}{\mu} \frac{\partial p}{\partial x} \end{aligned}$$

By performing the integration of the preceding equation with respect to y, we obtain

$$\frac{\partial u}{\partial y} = \frac{1}{\mu} \frac{\partial p}{\partial x} y + C_1 \quad \left\{ \because \frac{\partial p}{\partial x} \text{ is constant} \right\}$$

Integrating again $u = \frac{1}{\mu} \frac{\partial p}{\partial x} \frac{y^2}{2} + C_1 y + C_2 \quad \dots (7.15)$

Where C_1 and C_2 are constants of integrations. Their values are obtained from the two boundary conditions that is (i) at $y=0, u=0$ (ii) $y=b, u=0$.

The substitution of at $y = 0, u = 0$ in equation (7.15) gives

$$0 = 0 + C_1 \times 0 + C_2 \text{ or } C_2 = 0$$

The substitution of at $y = b, u=0$ in equation (7.15) gives

$$0 = \frac{1}{\mu} \frac{\partial p}{\partial x} \frac{b^2}{2} + C_1 \times b + 0$$

$$\therefore \quad C_1 = \frac{1}{\mu} \frac{\partial p}{\partial x} \frac{b^2}{2 \times b} = -\frac{1}{2\mu} \frac{\partial p}{\partial x} b$$

Substituting the values C_1 and C_2 in equation (7.15)

$$u = \frac{1}{2\mu} \frac{\partial p}{\partial x} y^2 + y \left(-\frac{1}{2\mu} \frac{\partial p}{\partial x} b \right)$$

or $u = -\frac{1}{2\mu} \frac{\partial p}{\partial x} [by - y^2] \quad \dots (7.16)$

In the given formula, $\mu, \partial p/\partial x,$ and b remain unchanged. This implies that u changes proportionally to the square of y . As a result, equation (7.16) represents the form of a parabola. As a result, the velocity profile within the parallel plate segment adopts a parabolic form. You can see this velocity distribution depicted in Figure 9 (a).

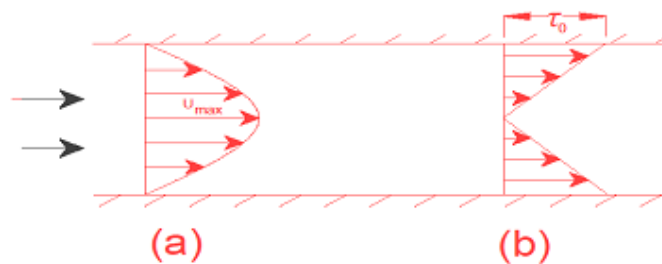

Figure 9

This diagram portrays the velocity and shear stress distribution along a section of parallel plates.

- The connection between maximum velocity and average velocity can be understood by noting that the highest velocity is reached when $y = b/2$. Plugging this value into equation (7.16), we get:

$$U_{max} = -\frac{1}{2\mu} \frac{\partial p}{\partial x} \left[b \times \frac{b}{2} - \left(\frac{b}{2}\right)^2 \right]$$

$$= -\frac{1}{2\mu} \frac{\partial p}{\partial x} \left[\frac{b^2}{2} - \frac{b^2}{4} \right] = -\frac{1}{2\mu} \frac{\partial p}{\partial x} \frac{b^2}{4} = -\frac{1}{8\mu} \frac{\partial p}{\partial x} b^2 \quad \dots (7.17)$$

The average velocity, \bar{u} , is obtained by dividing the discharge (Q) across the section by the area of the section ($b \times 1$). And the discharge Q is obtained by considering the rate of fluid through the strip of thickness dy and integrating it. The rate of flow through strip is

$$dQ = \text{Velocity at a distance } y \times \text{Area of strip}$$

$$= -\frac{1}{2\mu} \frac{\partial p}{\partial x} [by - y^2] \times dy \times 1$$

$$\therefore Q = \int_0^b dQ = \int_0^b -\frac{1}{2\mu} \frac{\partial p}{\partial x} [by - y^2] dy$$

$$= -\frac{1}{2\mu} \frac{\partial p}{\partial x} \left[\frac{by^2}{2} - \frac{y^3}{3} \right]_0^b = \frac{1}{2\mu} \frac{\partial p}{\partial x} \left[\frac{b^3}{2} - \frac{b^3}{3} \right]$$

$$= -\frac{1}{2\mu} \frac{\partial p}{\partial x} \frac{b^3}{6} = \frac{1}{12\mu} \frac{\partial p}{\partial x} b^3$$

$$\therefore \bar{u} = \frac{Q}{\text{area}} = \frac{\frac{1}{12\mu} \frac{\partial p}{\partial x} b^3}{t \times 1} = -\frac{1}{12\mu} \frac{\partial p}{\partial x} b^2 \quad \text{-----(7.18)}$$

Dividing equation (7.17) by equation (7.18), we get

$$\frac{U_{max}}{\bar{u}} = \frac{-\frac{1}{8\mu} \frac{\partial p}{\partial x} b^2}{-\frac{1}{12\mu} \frac{\partial p}{\partial x} b^2} = \frac{12}{8} = \frac{3}{2} \quad \text{-----(7.19)}$$

- Reducing pressure head over a specific length. By applying equation (7.18), we can deduce:

$$\bar{u} = -\frac{1}{12\mu} \frac{\partial p}{\partial x} b^2 \text{ or } \frac{\partial p}{\partial x} = -\frac{12\mu\bar{u}}{b^2}$$

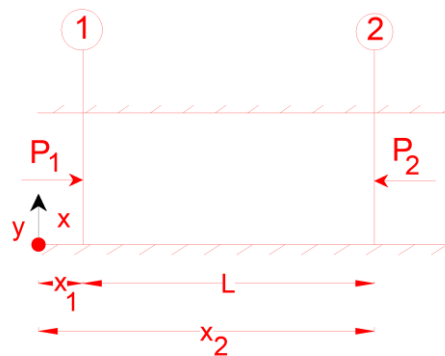

Figure 10

By performing integration with respect to x on this equation, we obtain:

$$\int_2^1 dp = \int_2^1 -\frac{12\mu\bar{u}}{b^2} dx$$

Or

$$p_1 - p_2 = -\frac{12\mu\bar{u}}{b^2} [x_1 - x_2] = \frac{12\mu\bar{u}}{b^2} [x_2 - x_1]$$

Or
$$p_1 - p_2 = \frac{12\mu\bar{u}L}{b^2} \quad \{\because x_1 - x_2 = L\}$$

If h_f is the drop of pressure head, then

$$h_f = \frac{p_1 - p_2}{\rho g} = \frac{12\mu\bar{u}L}{\rho g b^2} \quad \dots (7.20)$$

- **Distribution of Shear Stress.** This is achieved by inserting the value of u from equation (7.16) into:

$$\begin{aligned} \tau &= \mu \frac{\partial u}{\partial y} \\ \therefore \tau &= \mu \frac{\partial u}{\partial y} = \mu \frac{\partial}{\partial y} \left[-\frac{1}{2\mu} \frac{\partial p}{\partial x} (by - y^2) \right] = \mu \left[-\frac{1}{2\mu} \frac{\partial p}{\partial x} (b - 2y) \right] \\ \tau &= -\frac{1}{2} \frac{\partial p}{\partial x} [b - 2y] \quad \dots (7.21) \end{aligned}$$

Problem 4 Calculate : (a) the pressure gradient along flow, (b) the average velocity, and (c) the discharge for an oil of viscosity 1.962 Ns/m^2 flowing between two stationary parallel plates 1 m wide maintained 80 mm apart. The velocity midway between the plates is 1.5 m/s.

Solution. Given :

Viscosity, $\mu = 1.962 \text{ Ns/m}^2$

Width, $b = 1 \text{ m}$

Distance between plates, $t = 80 \text{ mm} = 0.08 \text{ m}$

Velocity midway between the plates, $U_{max} = 1.5 \text{ m/s}$.

- **Pressure gradient** $\left(\frac{dp}{dx} \right)$

Using equation (7.17) ,
$$U_{max} = -\frac{1}{8\mu} \frac{dp}{dx} t^2 \quad \text{or} \quad 1.5$$

$$= -\frac{1}{8 \times 1.962} \left(\frac{dp}{dx} \right) (0.08)^2$$

$$\therefore \frac{dp}{dx} = -\frac{1.5 \times 8 \times 1.962}{0.08 \times 0.08} = -3678.75 \text{ Ns/m}^2 \text{ per m. Ans.}$$

- **Average velocity** (\bar{u})

Using equation (7.19),
$$\frac{U_{max}}{\bar{u}} = \frac{3}{2} \quad \therefore \quad \bar{u} = \frac{2 U_{max}}{3} = \frac{2 \times 1.5}{3} = 1 \text{ m/s.}$$

Ans.

- **Discharge (Q)** $= \text{Area of flow} \times \bar{u} = b \times t \times \bar{u} = 1 \times 0.08 \times 1 = 0.08 \text{ m}^3/\text{sec. Ans.}$

Problem 5 Within a 150 mm thick wall, a horizontal crack measuring 50 mm in width and 3 mm in depth permits water to pass through. To determine the rate of water leakage through the crack, taking into account a pressure differential of 245.25 Ns/m^2 and a water viscosity of 0.01 poise

Solution. Given :

Width of crack, $b = 50 \text{ mm} = 0.05 \text{ m}$

Depth of crack, $t = 3 \text{ mm} = 0.003 \text{ m}$

Length of crack, $L = 150 \text{ mm} = 0.15\text{m}$
 $p_1 - p_2 = 245.25 \text{ N/m}^2$
 $\bar{u} = 0.01 \text{ poise} = \frac{0.01}{10} \frac{\text{N}_s}{\text{m}^2}$

Find rate of leakage (Q)

$(p_1 - p_2)$ is given by equation (7.20) as

$$p_1 - p_2 = \frac{12\mu\bar{u}L}{t^2} \text{ or } 245.25 = 12 \times \frac{0.01}{10} \times \frac{\bar{u} \times 0.15}{(0.003 \times 0.003)}$$

$$\therefore \bar{u} = \frac{245.25 \times 10 \times 0.003 \times 0.003}{12 \times 0.01 \times 0.15} = 1.22625 \text{ m/s}$$

$$\begin{aligned} \therefore \text{Rate of leakage} &= \bar{u} \times \text{area of cross-section of crack} \\ &= 1.22625 \times (b \times t) \\ &= 1.22625 \times 0.05 \times 0.003 \text{ m}^3/\text{s} = 1.84 \times 10^{-4} \text{ m}^3/\text{s} \\ &= 1.84 \times 10^{-4} \times 10^3 \text{ litre/s} = 0.184 \text{ litre/s. Ans.} \end{aligned}$$

IV. FACTORS FOR CORRECTING ENERGY OF MOTION AND LINEAR MOMENTUM

The kinetic energy correction factor, denoted as α , is determined by comparing the kinetic energy of the flow per second calculated using the actual velocity across a section with the kinetic energy of the flow per second calculated using the average velocity across the same section. To put it mathematically:

$$\alpha = \frac{\text{K.E./sec based on actual velocity}}{\text{K.E./sec based on average velocity}} \quad \dots (7.22)$$

Momentum Correction Factor. It is characterized by the ratio of the flow's momentum per second, calculated using the actual velocity, to the flow's momentum per second, and calculated using the average velocity across a specific section. This factor is denoted as β . Thus, in mathematical expression:

$$\beta = \frac{\text{Momentum per second based on actual velocity}}{\text{Momentum per second based on average velocity}} \quad \dots (7.23)$$

Problem 7.6 Establish that the correction factors for momentum and energy in the case of laminar flow inside a circular pipe are $4/3$ and 2.0 , respectively.

Solution (i) Momentum Correction Factor or β

The equation describing the velocity distribution within a circular pipe for laminar flow at any radius r is as follows: (7.4)

$$\text{Or } u = \frac{1}{4\mu} \left(-\frac{\partial p}{\partial x} \right) (R^2 - r^2) \quad \dots (i)$$

Imagine a small elemental area dA shaped like a ring, situated at a distance of r from the center and with a width of dr . In this context,

$$dA = 2\pi r \, dr$$

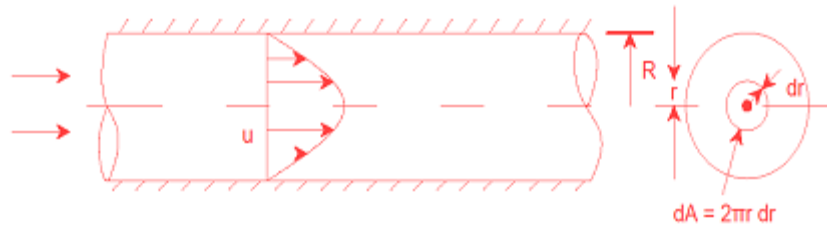

Figure 11

The rate at which the fluid streams through the ring
 $= dQ = \text{velocity} \times \text{area of ring element}$
 $= u \times 2\pi r \, dr$

The velocity at which the fluid passes through the ring.
 $= \text{mass} \times \text{velocity}$
 $= \rho \times dQ \times u = \rho \times 2\pi r \, dr \times u \times u = 2\pi \rho u^2 r \, dr$

\therefore The total momentum of the fluid that effectively traverses the section per second.
 $= \int_0^R 2\pi \rho u^2 r \, dr$

Replacing the value of u from equation (1)

$$\begin{aligned}
 &= 2\pi \rho \int_0^R \left[\frac{1}{4\mu} \left(-\frac{\partial p}{\partial x} \right) (R^2 - r^2) \right]^2 r \, dr \\
 &= 2\pi \rho \left[\frac{1}{4\mu} \left(-\frac{\partial p}{\partial x} \right) \right]^2 \int_0^R [R^2 - r^2] r \, dr \\
 &= 2\pi \rho \frac{1}{(16\mu^2)} \left(\frac{\partial p}{\partial x} \right)^2 \int_0^R (R^4 + r^4 - 2R^2 r^2) \, dr \\
 &= \frac{\mu \rho}{8\mu^2} \left(\frac{\partial p}{\partial x} \right)^2 \int_0^R (R^4 r + r^5 - 2R^2 r^3) \, dr \\
 &= \frac{\mu \rho}{8\mu^2} \left(\frac{\partial p}{\partial x} \right)^2 \left[\frac{R^2 r^2}{2} + \frac{r^6}{6} - \frac{2R^2 r^4}{4} \right]_0^R = \frac{\mu \rho}{8\mu^2} \left(\frac{\partial p}{\partial x} \right)^2 \left[\frac{R^6}{2} + \frac{R^6}{6} - \frac{2R^6}{4} \right] \\
 &= \frac{\mu \rho}{8\mu^2} \left(\frac{\partial p}{\partial x} \right)^2 \frac{6R^6 + 2R^6 - 2R^6}{12} \\
 &= \frac{\mu \rho}{8\mu^2} \left(\frac{\partial p}{\partial x} \right)^2 \times \frac{R^6}{12} = \frac{\mu \rho}{48\mu^2} \left(\frac{\partial p}{\partial x} \right)^2 R^6 \quad \dots\dots\dots(ii)
 \end{aligned}$$

Momentum of the fluid per second based on average velocity
 $= \frac{\text{mass of fluid}}{\text{sec}} \times \text{average velocity}$
 $= \rho A \bar{u} \times \bar{u} = \rho A \bar{u}^2$

Where A = area of cross section = πR^2 , \bar{u} = average velocity = $\frac{U_{max}}{2}$
 $= \frac{1}{2} \times \frac{1}{4\mu} \left(-\frac{\partial p}{\partial x} \right) R^2 \quad \left\{ \because U_{max} = \frac{1}{4\mu} \left(-\frac{\partial p}{\partial x} \right) R^2 \right\}$
 $= \frac{1}{8\mu} \left(-\frac{\partial p}{\partial x} \right) R^2$

\therefore Momentum/sec based on average velocity
 $= \rho \times \pi R^2 \times \left[\frac{1}{8\mu} \left(-\frac{\partial p}{\partial x} \right) R^2 \right]^2 = \rho \times \pi R^2 \times \frac{1}{64\mu^2} \left(-\frac{\partial p}{\partial x} \right)^2 R^4$

$$= \frac{\rho \pi \left(\frac{\partial p}{\mu x} \right)^2 R^6}{64 \mu^2} \dots\dots\dots(iii)$$

$$\begin{aligned} \therefore \beta &= \frac{\text{momentum / sec based on actual velocity}}{\text{momentum / sec based on average velocity}} \\ &= \frac{\frac{\mu \rho}{48 \mu^2} \left(\frac{\partial p}{\partial x} \right)^2 R^6}{\frac{\mu \rho}{64 \mu^2} \left(\frac{\partial p}{\partial x} \right)^2 R^6} = \frac{64}{48} = \frac{4}{3}. \text{ Ans.} \end{aligned}$$

(ii) The energy correction factor, designated as α , quantifies the kinetic energy associated with the fluid moving via the elementary ring with a radius 'r' and a width of 'dr' per second..

$$\begin{aligned} &= \frac{1}{2} \times \text{mass} \times u^2 = \frac{1}{2} \times \rho dQ \times u^2 \\ &= \frac{1}{2} \times \rho \times (u \times 2\pi r \, dr) \times u^2 = \frac{1}{2} \rho \times 2\pi r \, u^3 \, dr = \pi \rho r \, u^3 \, dr \end{aligned}$$

\therefore Total actual kinetic energy of flow per second

$$\begin{aligned} &= \int_0^R \pi \rho r \, u^3 \, dr = \int_0^R \pi \rho r \left[\frac{1}{4\mu} \left(-\frac{\partial p}{\partial x} \right) (R^2 - r^2) \right]^3 \, dr \\ &= \pi \rho \times \left[\frac{1}{4\mu} \left(-\frac{\partial p}{\partial x} \right) \right]^3 \int_0^R [R^2 - r^2]^3 \, r \, dr \\ &= \pi \rho \times \frac{1}{64\mu^3} \left(-\frac{\partial p}{\partial x} \right)^3 \int_0^R (R^6 - r^6 - 3R^4 r^2 + 3R^6 r^4) \, r \, dr \\ &= \frac{\pi \rho}{64\mu^3} \left(-\frac{\partial p}{\partial x} \right)^3 \int_0^R (R^6 r - r^7 - 3R^4 r^3 + 3R^6 r^5) \, dr \\ &= \frac{\pi \rho}{64\mu^3} \left(-\frac{\partial p}{\partial x} \right)^3 \left[\frac{R^6 r^2}{2} - \frac{r^8}{8} - \frac{3R^4 r^4}{4} + \frac{3R^6 r^6}{6} \right]_0^R \\ &= \frac{\pi \rho}{64\mu^3} \left(-\frac{\partial p}{\partial x} \right)^3 \left[\frac{R^8}{2} - \frac{R^8}{8} - \frac{3R^8}{4} + \frac{3R^6}{6} \right] \\ &= \frac{\pi \rho}{64\mu^3} \left(-\frac{\partial p}{\partial x} \right)^3 R^8 \left[\frac{12-3-18+12}{24} \right] \\ &= \frac{\pi \rho}{64\mu^3} \left(-\frac{\partial p}{\partial x} \right)^3 \frac{R^8}{8} \end{aligned}$$

Kinetic energy of the flow based on average velocity

$$= \frac{1}{2} \times \text{mass} \times \bar{u}^2 = \frac{1}{2} \times \rho A \bar{u} \times \bar{u}^2 = \frac{1}{2} \times \rho A \bar{u}^3$$

Substituting the value of $A = (\pi R^2)$

And $\bar{u} = \frac{1}{8\mu} \left(-\frac{\partial p}{\partial x} \right) R^2$

Kinetic energy of the flow based on average velocity

$$= \frac{1}{2} \times \text{mass} \times \bar{u}^2 = \frac{1}{2} \times \rho A \bar{u} \times \bar{u}^2 = \frac{1}{2} \times \rho A \bar{u}^3$$

Substituting the value of $A = (\pi R^2)$

And $\bar{u} = \frac{1}{8\mu} \left(-\frac{\partial p}{\partial x} \right) R^2$

∴ Kinetic energy of the flow/sec

$$\begin{aligned}
 &= \frac{1}{2} \times \rho \times \pi R^2 \times \left[\frac{1}{8\mu} \left(-\frac{\partial p}{\partial x} \right) R^2 \right]^3 \\
 &= \frac{1}{2} \times \rho \times \pi R^2 \times \frac{1}{64 \times 8\mu^3} \left(-\frac{\partial p}{\partial x} \right)^3 \times R^6 \\
 &= \frac{\rho\pi}{128 \times 8\mu^3} \times \left(-\frac{\partial p}{\partial x} \right)^3 \times R^8 \quad \dots (V)
 \end{aligned}$$

$$\begin{aligned}
 \therefore \alpha &= \frac{\text{K.E./sec based on actual velocity}}{\text{K.E./sec based on average velocity}} = \frac{\text{equation (4)}}{\text{equation (5)}} \\
 &= \frac{\frac{\pi\rho}{64\mu^3} \left(-\frac{\partial p}{\partial x} \right)^3 \frac{R^8}{8}}{\frac{\rho\pi}{128 \times 8\mu^3} \left(-\frac{\partial p}{\partial x} \right)^3 \times R^8} = \frac{128 \times 8}{64 \times 8} = \mathbf{2.0. Ans.}
 \end{aligned}$$

V. POWER DISSIPATED IN VISCOUS FLOW

Regarding the lubrication of machine components, oil is employed. The oil stream within a bearing serves as an instance of viscous flow. When a lubricating bearing uses oil with high viscosity, it leads to increased resistance, resulting in higher power dissipation. Conversely, if a low-viscosity oil is utilized, it becomes difficult to maintain the required film between the moving component and the stationary metal surface. Consequently, wear between the two surfaces occurs. Thus, it becomes essential to select an oil with the appropriate viscosity for lubrication purposes. The objective is to compute the power required to counteract viscous resistance in the following situations:

- Viscous Friction in Journal Bearings
- Viscous Friction in Footstep Bearings
- Viscous Friction in Collar Bearings

1. Viscous Friction in Journal Bearings: Imagine a shaft with a diameter of D rotating within a journal bearing. The gap between the shaft and the journal bearing is occupied by a viscous oil. The layer of oil in contact with the shaft revolves at the shaft's speed, while the oil layer touching the journal bearing remains stationary. Consequently, the oil creates a viscous resistance against the rotating shaft.

Let N = speed of shaft in r.p.m.
 t = thickness of oil film
 L = length of oil film

$$\therefore \text{Angular speed of the shaft, } \omega = \frac{2\pi N}{60}$$

$$\therefore \text{Tangential speed of the shaft} = \omega \times R \text{ or } V = \frac{2\pi N}{60} \times \frac{D}{2} = \frac{\pi DN}{60}$$

The shear stress in the oil is given by, $\tau = \mu \frac{du}{dy}$

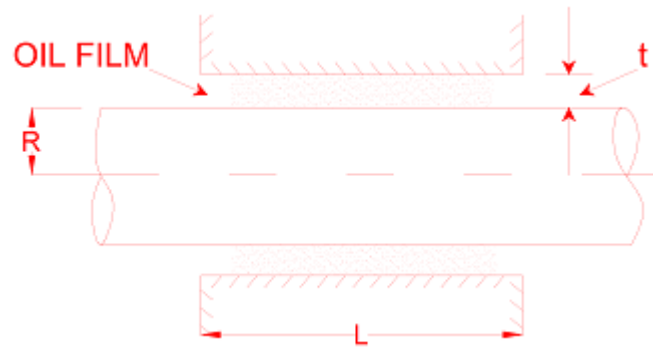

Figure 12: Journal Bearing.

As the thickness of oil film is very small, the velocity distribution in the oil film can be assumed as linear.

Hence

$$\frac{du}{dy} = \frac{V-0}{t} = \frac{V}{t} = \frac{\pi DN}{60 \times t}$$

∴

$$t = \mu \frac{\pi DN}{60 \times \tau}$$

∴ The shear force or the opposition arising from viscosity = $\tau \times$
The shaft's exposed area

$$= \frac{\mu \pi DN}{60 \times t} \times \pi DN = \frac{\mu \pi^2 D^2 NL}{60t}$$

∴ Torque required to overcome the viscous resistance,

$$T = \text{Viscous resistance} \times \frac{D}{2}$$

$$= \frac{\mu \pi^2 D^2 NL}{60t} \times \frac{D}{2} = \frac{\mu \pi^2 D^3 NL}{120t}$$

∴ Power consumed in counteracting viscous resistance

$$* P = \frac{2\pi NT}{60} = \frac{2\pi N}{60} \times \frac{\mu \pi^2 D^3 NL}{120t}$$

$$= \frac{\mu \pi^2 D^3 N^2 L}{60 \times 60 \times t} \text{ watts. Ans. } \dots\dots\dots(7.24)$$

Problem 7 Calculate the power consumed by the bearing when a shaft with a 10 cm diameter rotates at 500 revolutions per minute within a journal bearing with a diameter of 10.02 cm and a length of 20 cm. The space between the shaft and bearing is filled with oil of viscosity 0.8 poise.

Solution . Given :

Dia. of shaft, $D = 10 \text{ cm or } 0.1 \text{ m}$

Dia. of bearing, $D_1 = 10.02 \text{ cm or } 0.1002 \text{ m}$

Length, $L = 20 \text{ cm or } 0.2 \text{ m}$

$$\mu \text{ of oil} = 0.8 \text{ poise} = \frac{0.8}{10} \frac{N_s}{m^2}$$

$N = 500 \text{ r.p.m.}$

Power = ?

$$\begin{aligned} \therefore \text{Thickness of oil film, } t &= \frac{D_1 - D}{2} = \frac{10.02 - 10}{2} \\ &= \frac{0.02}{2} = 0.01 \text{ cm} = 0.01 \times 10^{-2} \text{ m} = 0.0001 \text{ m} \end{aligned}$$

$$\text{Tangential speed of shaft, } V = \frac{\pi DN}{60} = \frac{\pi \times 0.1 \times 500}{60} = 2.618 \text{ m/s}$$

$$\text{Shear stress } \tau = \mu \frac{du}{dy} = \mu \frac{V}{t} = \frac{0.8}{10} \times \frac{2.618}{0.0001} = 2094.4 \text{ N/m}^2$$

$$\begin{aligned} \therefore \text{Shear force (F)} &= \tau \times \text{Area} = 2094.4 \times \pi D \times L \\ &= 2094.4 \times \pi \times 0.1 \times 0.2 = 131.6 \text{ N} \end{aligned}$$

$$\text{Resistance torque } T = F \times \frac{D}{2} = 131.6 \times \frac{0.1}{2} = 6.579 \text{ Nm}$$

$$\text{Power} = \frac{2\pi NT}{60} = \frac{2\pi \times 500 \times 6.579}{60} = 344.51 \text{ W. Ans.}$$

Problem 7.8 A shaft 150 mm diameter runs in a bearing of length 300 mm with a radial clearance of 0.04 mm at 40 r.p.m. Find the velocity of the oil, if the power required to overcome the viscous resistance is 220.725 watts.

Solution. Given :

$$D = 150 \text{ mm} = 0.15 \text{ m}$$

$$L = 300 \text{ mm} = 0.3 \text{ m}$$

$$t = 0.04 \text{ mm} = 0.04 \times 10^{-3} \text{ m}$$

$$N = 40 \text{ r.p.m.}; H.P. = 220.725 \text{ watts}$$

$$P = \frac{\mu \pi^3 D^3 N^2 L}{60 \times 60 \times t} \quad \text{or} \quad 220.725 = \frac{\mu \pi^3 \times (0.15)^3 \times (40)^2 \times 0.3}{60 \times 60 \times 0.04 \times 10^{-3}}$$

$$\begin{aligned} \therefore \mu &= \frac{220.725 \times 60 \times 60 \times 0.04 \times 10^{-3}}{\pi^3 \times (0.15)^3 \times (40)^2 \times 0.3} \frac{N_s}{m^2} \\ &= 0.632 \frac{N_s}{m^2} = 0.632 \times 10 = 6.32 \text{ poise. Ans.} \end{aligned}$$

- 2. Viscous Friction in Footstep Bearings:** Viscous Friction in Footstep Bearings: Illustrated in Figure 7.13 is a footstep bearing configuration, In a scenario where a vertical shaft is spinning. There is a layer of oil between the underside of the shaft and the bearing. In this scenario, the radius of the shaft's surface in contact with the oil isn't uniform, unlike that in a journal bearing. Consequently, the calculation of viscous resistance in a footstep bearing involves the consideration of a small circular ring element with a radius of r and a thickness of dr , as depicted in Figure 7.13.

Let N = speed of the shaft

t = Oil film thickness

R = radius belonging to the shaft

Area of the elementary ring = $2\pi r dr$

Now shear stress is given by $t = \mu \frac{du}{dy} = \mu \frac{V}{t}$

where V is the tangential velocity of shaft at radius r and is equal to

$$\omega \times r = \frac{2\pi N}{60} \times r$$

$$\begin{aligned} \therefore \text{Shear force on the ring} &= dF = \tau \times \text{area of elementary ring} \\ &= \mu \times \frac{2\pi N}{60} \times \frac{r}{t} \times 2\pi r dr = \frac{\mu}{15} \frac{\mu \pi^2 N r^2}{t} dr \end{aligned}$$

\therefore Torque needed to counteract the Frictional resistance due to viscosity,

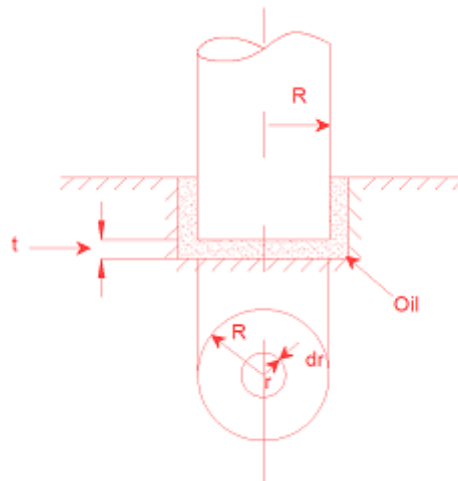

Figure 13: Pivot Bearing

$$dT = dF \times r$$

$$= \frac{\mu}{15t} \mu \pi^2 N r^2 dr \times r = \frac{\mu}{15t} \mu \pi^2 N r^3 dr \quad \dots(7.25)$$

\therefore Total torque required to overcome the viscous resistance,

$$T = \int_0^R dT = \int_0^R \frac{\mu}{15t} \mu \pi^2 N r^3 dr$$

$$= \frac{\mu}{15t} \pi^2 N \int_0^R r^3 dr = \frac{\mu}{15t} \pi^2 N \left[\frac{r^4}{4} \right]_0^R = \frac{\mu}{15t} \pi^2 N \frac{R^4}{4}$$

$$= \frac{\mu}{60t} \pi^2 N R^4 \quad \dots(7.25A)$$

\therefore Power absorbed ,

$$P = \frac{2\pi NT}{60} \text{ watts}$$

$$= \frac{2\pi N}{60} \times \frac{\mu}{60t} \pi^2 N R^4 = \frac{\mu \pi^3 N^2 R^4}{60 \times 30t} \quad \dots(7.26)$$

Problem 9 Determine the torque needed to spin a vertical shaft with an 80 mm diameter at a speed of 800 revolutions per minute. The lower end of the shaft is supported by a foot-step bearing, with both the shaft end and the bearing surface being flat and separated by a 0.75 mm thick oil film. The oil's viscosity is specified as 1.2 poise.

Solution. Given :

Dia. of shaft, $D = 80 \text{ mm} = 0.08 \text{ m}$

$$\therefore R = \frac{D}{2} = \frac{0.08}{2} = 0.04 \text{ m}$$

$$N = 800 \text{ r.p.m.}$$

Oil film thickness, $t = 0.75 \text{ mm} = 0.00075 \text{ m}$

$$\mu = 1.2 \text{ poise} = \frac{1.2}{10} \frac{N_s}{m^2}$$

The torque required is given by equation (9.19) or

$$T = \frac{\mu}{60t} \pi^2 N R^4 N m$$

$$= \frac{1.2}{10} \times \frac{\pi^2 \times 800 \times (0.04)^4}{60 \times 0.00075} = 0.054 \text{ Nm. Ans.}$$

- 3. Viscous Friction in Collar Bearings:** Viscous Friction in Collar Bearings. Fig.14 depicts the collar bearing, In this setup, a consistent oil film thickness separates the collar's surface from the bearing surface.

Let N = Rotational speed of the shaft in revolutions per minute
 R_1 = Inner radius of the collar
 R_2 = Outer radius of the collar
 t = Oil film thickness

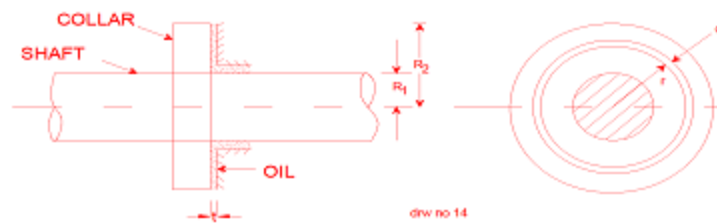

Figure 14: Sleeve bearing

Imagine An elementary circular ring having a radius 'r' and a radial width 'dr' on the bearing surface. In this scenario, the torque (dT) required to overcome the viscous resistance exerted on the basic circular ring corresponds to the formula as presented in the equation. (7.25A). or

$$dT = \frac{\mu}{15t} \pi^2 N r^3 dr$$

∴ The total torque required to conquer the viscous resistance along the entire collar is.

$$T = \int_{R_1}^{R_2} dT = \int_{R_1}^{R_2} \frac{\mu}{15t} \pi^2 N r^3 dr = \frac{\mu}{15t} \pi^2 N \left[\frac{r^4}{4} \right]_{R_1}^{R_2}$$

$$= \frac{\mu}{15t \times 4} \pi^2 N [R_2^4 - R_1^4] = \frac{\mu}{60t} \pi^2 N [R_2^4 - R_1^4] \quad \dots (7.27)$$

∴ Power absorbed in overcoming viscous resistance

$$P = \frac{2\pi NT}{60} = \frac{2\pi N}{60} \times \frac{\mu}{60t} \pi^2 N [R_2^4 - R_1^4]$$

$$= \frac{\mu \pi^3 N^2}{60 \times 30t} [R_2^4 - R_1^4] \text{ watts.} \quad \dots (7.28)$$

Problem 9 A collars bearing with an external diameter of 200 mm and an internal diameter of 100 mm is employed to handle the axial thrust of a shaft. The collar surface and the bearing uphold an oil film with a 0.3 mm thickness in between them. Calculate the power expended in overcoming viscous resistance as the shaft rotates at a speed of 250 revolutions per minute.. Consider the viscosity as $\mu = 0.9$ poise.

Solution. Given :

External Dia. of collar, $D_2 = 200 \text{ mm} = 0.2 \text{ m}$

$$\therefore R_2 = \frac{D_2}{2} = \frac{0.2}{2} = 0.1 \text{ m}$$

Internal Dia. of collar, $D_1 = 100 \text{ mm} = 0.1 \text{ m}$

$$\therefore R_1 = \frac{D_1}{2} = \frac{0.1}{2} = 0.05 \text{ m}$$

Thickness of oil film, $t = .3 \text{ mm} = 0.0003 \text{ m}$

$$N = 250 \text{ r.p.m.}$$

$$\mu = 0.9 \text{ poise} = \frac{0.9 \text{ N}_s}{10 \text{ m}^2}$$

The power required is given by equation (9.22) or

$$\begin{aligned} P &= \frac{\mu \pi^3 N^2}{60 \times 60 \times t} [R_2^4 - R_1^4] \\ &= \frac{0.9}{10} \times \frac{\pi^3 \times 250^2 \times [0.1^4 - (0.05)^4]}{60 \times 60 \times 0.0003} \\ &= 322982 [1 \times 10^{-4}] \\ &= 322982 \times 0.00009375 = 30.28 \text{ W. Ans.} \end{aligned}$$

VI. TURBULENT FLOW

Turbulent is a state of flow in which orderly motion of fluid particles collapses to from eddies that spread into the entire region of flow. It is rather a state of instability of fluid motion caused by movements of adjacent layers at different velocities and the associated viscous forces in between. Sources of disturbances that would cause turbulence and eddy currents may be varied such as roughness projections on a boundary surface, sharp discontinuities in the boundary geometry, the trailing edge of aero foils and zones of boundary layer separation. Up to a certain velocity these disturbances are not allowed to spread by the damping and stabilizing effect of viscosity. However, beyond that stage even small disturbances are not damped out. They move along with the flow spreading into the whole region leaving only a thin layer close to the wall. The individual disturbances lose their identity and the flow becomes turbulent, that is, one of total disorder.

An examination of the diffusion of the dye filament in Reynolds experiment would suggest that the fluid particles acquire secondary motions in the specified direction transverse to the primary flow. Thus as a consequence of turbulent flow is in a direction perpendicular to the primary flow. Thus the resulting turbulent flow is the superposition of these irregular secondary motion on the primary motion of the stream. The velocity at any location within turbulent flow fluctuates in both magnitude and direction. In other words, turbulence is three dimensional in character. Strictly speaking, turbulent flow can never be steady as per the usual definition. However, a recognizable pattern of fluctuations can be observed (see Fig.7.15) in the variation of velocity with time so that we may call the flow quasi steady. Though it is impossible to describe exactly the random nature of the fluctuations, statistically one can think of a time averaged mean velocity, \bar{u} . Then the instantaneous velocity u at any point can be written equal to the time average velocity plus a fluctuating component u' which is found to be of the order of one per cent of stream velocity. That is, for the three components of velocity

$$\bar{u} = u + u', \quad \bar{v} = v + v' \text{ and } \bar{w} = w + w'$$

$$\text{and} \\ \bar{u} = \frac{1}{T} \int_0^T u \, dt \text{ etc.}$$

In this context, T denotes the duration for which the average is computed.

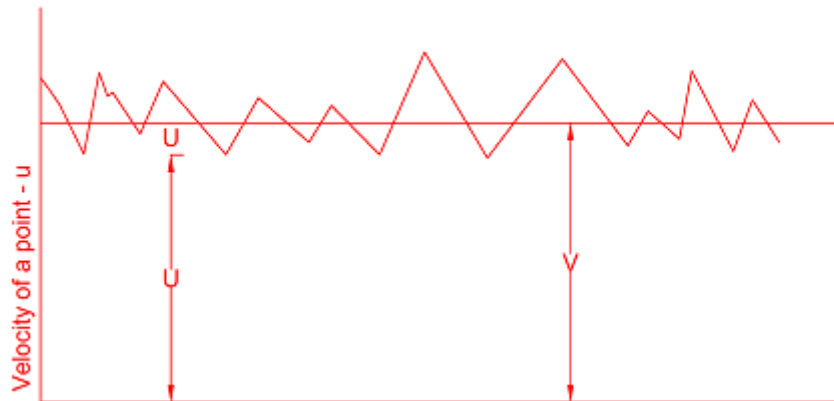

Figure 15

The magnitude of fluctuating component is a measure of the intensity of turbulence. From the definition it is clear that the mean of u' would be zero. But the statistical quantity root-mean-square may serve our purpose. Thus we have the intensity of turbulence

$$\text{Intensity} = \sqrt{\overline{u'^2}} = \left(\frac{1}{T} \int_0^T u'^2 dt \right)^{\frac{1}{2}} \quad \text{etc.}$$

which may vary with location and degree of turbulence. The velocity fluctuations in the different directions can be measured accurately by the hotwire anemometer.

1. Stresses in Turbulent Flow: The normal and shear stresses exist in turbulent flow in its own way. The fluctuations of motion practically do not have any impact on the normal stress or the pressure. In any pressure measuring device, these turbulent fluctuations get damped out and we measure only the mean value which is the one wanted in engineering calculations.

The case of shear stress in turbulent flow is entirely different. In laminar flow the shearing resistance is offered by two factors. One is due to cohesion, the mutual attraction between the molecules. The other is due to the interference of the molecules vibrating to the amplitude of their mean free path between layers of different velocities. This is termed as molecular activity. The fluctuations in turbulent flow are just analogous to this molecular activity but in a macroscopic scale. Lumps of fluids fluctuate in the perpendicular direction to the primary flow, collide and exchange momentum due to differential velocities, causing considerable dissipation of energy and hence large resistance to flow. The momentum exchange due to complex mixing is so great that the effective viscosity of the fluid appears hundreds of times as large as molecular viscosity, contributing to high frictional losses. The fact is evident from the following observations for a circular pipe. Eq. (7.8) states that the loss of head under laminar flow

$$h_L \propto V$$

which plots as a straight line in Fig.16 As the velocity is increased to bring in turbulence, the head loss is observed to increase sharply initially and then to attain a greater rate of increase than for laminar flow. Latter analysis revealed that for turbulent flow

$$h_L \propto V^n$$

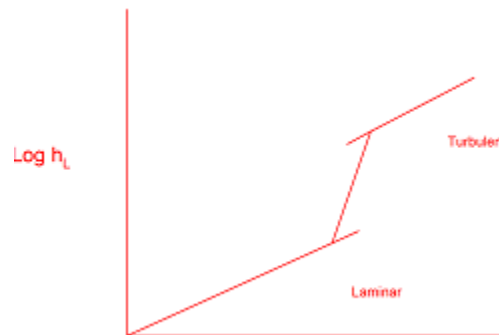

Figure 16: Losses in Circular Pipes.

Where n is close to 2. This is also evident from the fact that momentum and energy are transported in the transverse direction by the random motion of turbulent eddies. Consequently, a more uniform velocity distribution is produced (see Fig 7.17). Since the resistance to flow or shear stress at the turbulent flow (because of steeper slope) offers greater resistance than laminar flow.

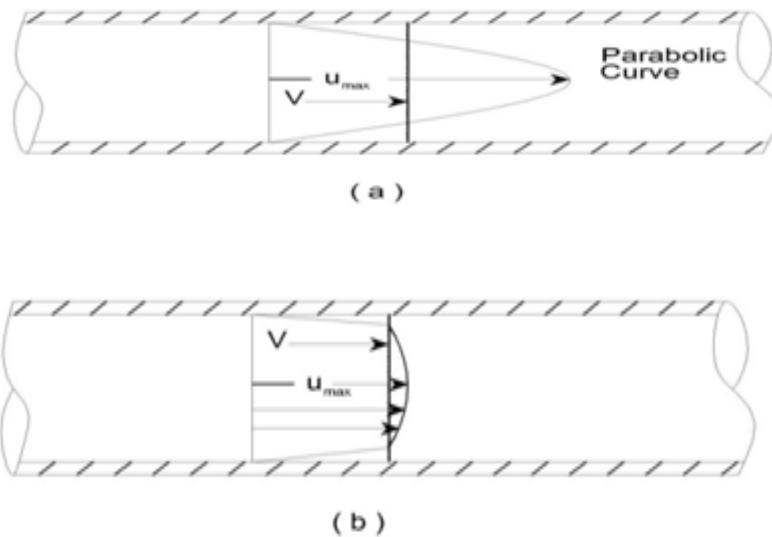

Figure 17: comparison of Velocity profile for (a) laminar , and (b) turbulent pipe flow.

- 2. Boussinesq Eddy Viscosity:** To account for the increased shear stress due to turbulence, many semi empirical methods were proposed. The first of these, given by Bossinesq is a turbulent shear stress in terms of an eddy viscosity analogous to the Newton's equation of viscosity. He wrote the total shear stress as

$$\tau = \tau_{laminar} + \tau_{turbulent}$$

$$\tau = \mu \frac{d\bar{u}}{dy} + \eta \frac{d\bar{u}}{dy} \dots\dots\dots(7.29)$$

where

- \bar{u} = time averaged mean velocity
- μ = molecular viscosity
- η = eddy viscosity

There is only convenience rather than merit to write in the form of Eq. (7.17) because the eddy viscosity η is not a fixed quantity unlike the molecular viscosity. It is a property of the fluid motion that depended upon the location and the intensity of turbulence. Except at the vicinity of the wall, turbulent shear stress τ , is much greater than the laminar shear stress $\mu (d\bar{u}/dy)$ is often neglected.

VII. LOSS OF HEAD DUE TO FRICTION IN TURBULENT FLOW-DARCY EQUATION

For turbulent flow in pipes, experimental observations have revealed that the effects of viscous friction attributed to the fluid are proportionate to;

- I. The pipe length, denoted as "L."
 - II. The wetted perimeter, represented as "P."
 - III. V^n , where "V" signifies the average flow velocity, and "n" is an exponent that ranges from 1.5 to 2, depending on factors such as the material and surface characteristics of the pipe. For commercial pipes with turbulent flow, n is typically equal to 2.
- Equation for the loss of head resulting from friction in pipes.

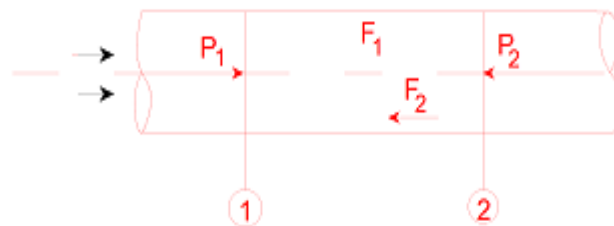

Figure 18

Fig. 18. shows a horizontal pipe having steady flow, Consider control volume enclosed between sections 1 and 2 of the pipe, L distance apart. Where let the intensities of pressure be p_1 and p_2 respectively. By applying Bernouli's equation between the sections 1 and 2, we obtain

$$\frac{p_1}{w} + \frac{V_1^2}{2g} + Z_1 = \frac{p_2}{w} + \frac{V_2^2}{2g} + Z_2 + h_f$$

Since

$$V_1 = V_2 = V \text{ and } Z_1 = Z_2$$

$$\text{Loss of head} = h_f = \frac{p_1}{w} - \frac{p_2}{w} = \frac{p_1}{\rho g} - \frac{p_2}{\rho g} \dots\dots(i)$$

i.e., the pressure intensity will be reduced by the frictional resistance in the direction of flow and the difference of pressure heads between any two sections is equal to the loss of head due to friction between these sections.

Further let 'f' be the frictional resistance per unit area at unit velocity, then frictional resistance (F_1)

$$\begin{aligned} F_1 &= f' \times \pi dl \times V^2 \\ &= f' \times PL \times V^2 \quad \dots(ii) \end{aligned}$$

Where p is the wetted perimeter of the pipe.

The pressure forces at the sectional 1 and 2 are (p_1A) and (p_2A) respectively. Thus resolving all the forces horizontally, we have

$$p_1A = p_2A + F_1 \quad \dots(7.30)$$

Or $(p_1 - p_2)A = f' \times PL \times V^2$ [\because from(ii) $F_1 = f' \times PL \times V^2$]

Or $(p_1 - p_2) = f' \times \frac{P}{A} \times LV^2$

Dividing both sides by the specific weight ρg of the flowing fluid

$$\frac{p_1 - p_2}{\rho g} = \frac{f'}{\rho g} \times \frac{P}{A} LV^2$$

But $h_f = \frac{p_1 - p_2}{\rho g}$, then

$$h_f = \frac{f'}{\rho g} \times \frac{P}{A} \times LV^2 \quad \dots(iii)$$

The ratio of cross-sectional area of the flow (wetted area) to the perimeter in contact with the fluid (wetted perimeter) i.e., $\left(\frac{A}{P}\right)$ is called *hydraulic mean depth* (H.M.D.) and it is represented by m .

Then $h_f = \frac{f'}{\rho g} \times \frac{LV^2}{m}$

For pipes running full

$$m = \frac{A}{P} = \frac{\left(\frac{\pi D^2}{4}\right)}{\pi D} = \frac{D}{4}$$

Substituting this in the equation for h_f

$$h_f = \frac{4f' LV^2}{\rho g D} \quad \dots(iv)$$

Putting $\frac{f'}{\rho} = \frac{f}{2}$ where f is known as co-efficient of friction.

$$h_f = \frac{4fLV^2}{2gD} \quad \dots(7.31)$$

$$h_f = \frac{4fLV^2}{2gD} \quad \dots(7.31)$$

Equation 7.31 is known as Darcy-Weisbach equation. This equation is commonly used for finding loss of head due to friction in pipes.

Sometimes equation (7.31) can be written as

$h_f = (f * L * V^2) / (d * 2g)$ defines the friction factor, denoted as 'f,' in cases of viscous flow.

Equation for the coefficient of friction in relation to shear stress:

Refer 7.7,

$$(P_1 - P_2) A = \text{Force due to shear stress, } \tau_0$$

(Where, τ_0 = shear stress at the pipe wall)
= Shear stress (τ_0) \times surface area
= $\tau_0 \times \pi DL$

Or, $(P_1 - P_2) \frac{\pi}{4} D^2 = \tau_0 \times \pi DL$

Or, $(P_1 - P_2) \frac{D}{4} = \tau_0 L$

Or, $(P_1 - P_2) = \frac{4\tau_0 \times L}{D}$ -----(7.32)

Eqn. (7.31) can be written as

$$h_f = \frac{p_1 - p_2}{\rho g} = \frac{4fL V^2}{D \times 2g}$$

Or, $(P_1 - P_2) = \frac{4fL V^2}{D \times 2g} \times \rho g$ -----(7.33)

Equating eqns. (7.32) and (7.33), we get

$$\frac{4\tau_0 L}{D} = \frac{4fL V^2}{D \times 2g} \times \rho g$$

Or, $\tau_0 = \frac{fV^2 \times \rho g}{2g} = \frac{f\rho V^2}{2}$

Or, $f = \frac{2\tau_0}{\rho V^2}$ -----(7.34)

VIII. HEAD LOSS CAUSED BY VISCOUS FLOW RESISTANCE

The decrease in pressure level, denoted as h_f , within A tube with a specific diameter D,

A viscous fluid flowing through with A fluid with a viscosity of μ is moving with an average velocity of \bar{u} , is determined using the Hagen-Poiseuille formula, represented by equation (7.8) as:

$$h_f = \frac{32\mu\bar{u}L}{\rho g D^2} \dots(i)$$

Where L =length of pipe

The loss of head due to friction is given by

$$h_f = \frac{4fL V^2}{2gD} = \frac{4fL \bar{u}^2}{2gD} \dots(ii) \{ \because \text{The velocity within a pipe corresponds to the average velocity. } \therefore v = \bar{u} \}$$

In this equation, "f" represents the coefficient of friction between the pipe and the fluid.

Equalizing (i) and (ii), we get $\frac{32\mu\bar{u}L}{\rho g D^2} = \frac{4fL \bar{u}^2}{2gD}$

$$f = \frac{32\mu\bar{u}L}{\rho g D^2} \times \frac{2gD}{4L\bar{u}^2} = \frac{16\mu}{\bar{u} \cdot \rho \cdot D}$$

$$= 16X \frac{\mu}{\rho \cdot V \cdot D} = 16X \frac{1}{Re}$$

Re = Reynolds number = $\frac{\rho \cdot V \cdot D}{\mu}$

Therefore $f = \frac{16}{Re}$ (7.35)

Problem 10 Flowing within a pipe of 150 mm in diameter, water exhibits a coefficient of friction denoted by $f = 0.05$. At a location 40 mm distant from the pipe's central axis, the shear stress measures 0.01962 N/cm². Our task is to determine the shear stress at the inner wall of the pipe.

Solution. Given :

Dia. of pipe, $D = 150 \text{ mm} = 0.15 \text{ m}$

frictional coefficient, $f = 0.05$

Shear stress at $r = 40 \text{ mm}$, $\tau = 0.01962 \text{ N/cm}^2$

Let the shear stress at pipe wall = τ_0 .

First find whether the flow is viscous or not. The flow will be viscous if Reynold number Re is less than 2000.

Using equation (7.35), we get $f = \frac{16}{Re}$ or $0.05 = \frac{16}{Re}$

$$\therefore Re = \frac{16}{0.05} = 320$$

This means flow is viscous. The expression for shear stress in the context of viscous flow through a pipe is provided as follows by the equation (7.2) as

$$\tau = -\frac{\partial p}{\partial x} \frac{r}{2}$$

But $\frac{\partial p}{\partial x}$ is constant across a section. Across a section, there is no variation of x and there is no variation of p .

$$\therefore \tau \propto r$$

At the pipe wall, radius = 100 mm and shear stress is τ_0

$$\therefore \frac{\tau}{r} = \frac{\tau_0}{75} \quad \text{or} \quad \frac{0.01962}{40} = \frac{\tau_0}{75}$$

$$\therefore \tau_0 = \frac{75 \times 0.01962}{40} = 0.03678 \text{ N/cm}^2. \text{ Ans.}$$

Exercise Questions:

1. Define the terms: viscosity, kinematic viscosity gradient and pressure gradient.
2. What do you mean by “viscous flow”?
3. Drive an expression for the velocity distribution for viscous flow through a circular pipe. Also sketch the velocity distribution and shear stress distribution across the section of the pipe.
4. Prove that the maximum velocity in the circular pipe for viscous flow is equal to two times the average velocity of the flow. (Delhi university, December 2002)
5. Find an expression for the loss of head of viscous fluid flowing through a circular pipe

6. What is Hagen poiseuille's formula? Derive an expression for Hagen poiseuille's formula.
7. Prove that the velocity distribution for viscous flow between two parallel plates when both plates are fixed across a section is parabolic in nature. Also [prove that the maximum velocity is equal to one and a half times the average velocity.
8. Show that the difference of pressure head for a given length of the two parallel plates which are fixed and through which viscous fluid is flowing is given by

$$h_f = 12\mu\bar{u}L/\rho g t^2$$
Where μ = viscosity of fluid, \bar{u} = average velocity,
 t = distance between two parallel plates, L = length of the plates,
9. Define the terms: kinetic energy correction factor and momentum correction factor.
10. Prove that for viscous flow through a circular pipe the kinetic energy correction factor is equal to 2 while momentum correction factor = 4/3.
11. A shaft is rotating in a journal bearing. The clearance between the shaft and the bearing filled with a viscous resistance.
12. Prove that power absorbed in overcoming viscous resistance in footstep bearing is given by

$$P = \mu\pi^3 N^2 R^4 / 60 \cdot 30t$$
Where R = Radius of the shaft, N = speed of the shaft,
 t = clearance between shaft and footstep bearing, μ = viscosity of fluid.
13. Establish that the coefficient of friction for viscous flow through a circular pipe can be expressed as.
 $f = 16/Re$ where $R =$ Reynolds number.

Demonstrate that the coefficient of viscosity, as determined by the dash-pot arrangement, can be described as,

$$\mu = 4Wt^3/3\pi LD^3V$$

Where W = weight of the piston, t = clearance between dash-pot and piston,
 L = length of piston, D = diameter of piston,
 V = velocity of piston.

14. What are the different methods of determining the co-efficient of viscosity of liquid ? Describe any two methods in details.
15. Prove that the loss of pressure head for the viscous flow through a circular pipe is given by

$$h_f = 32\mu\bar{u}L/\rho g b^2$$
Where \bar{u} = average velocity, w = specific weight.
16. For a laminar steady flow, prove that the pressure gradient in direction of motion is equal to the shear gradient normal to the direction of motion.
17. Describe Reynolds experiments to demonstrate the two types of flow.
18. For the laminar flow through a circular pipe ,prove that:
 - The shear stress variation across the section of the pipe is linear and
 - The velocity variation is parabolic.

Objective Questions

1. The torque required to overcome viscous resistance of a footstep bearing is (where μ = Viscosity of the oil, N = Speed of the shaft, R = Radius of the shaft, and t = Thickness of the oil film)

- A. $\frac{\mu \pi^2 NR}{60 t}$
B. $\frac{\mu \pi^2 NR^2}{60 t}$
C. $\frac{\mu \pi^2 NR^3}{60 t}$
D. $\frac{\mu \pi^2 NR^4}{60 t}$

Answer: Option D

2. The torque required to overcome viscous resistance of a collar bearing is (where R_1 and R_2 = External and internal radius of collar)

- A. $\frac{\mu \pi^2 N}{60 t} (R_1 - R_2)$
B. $\frac{\mu \pi^2 N}{60 t} (R_1^2 - R_2^2)$
C. $\frac{\mu \pi^2 N}{60 t} (R_1^3 - R_2^3)$
D. $\frac{\mu \pi^2 N}{60 t} (R_1^4 - R_2^4)$

Answer: Option D

3. 65. The power absorbed (in watts) in overcoming the viscous resistance of a footstep bearing is

- A. $\frac{\mu \pi^3 N^2 R^2}{1800 t}$
B. $\frac{\mu \pi^3 N^2 R^4}{1800 t}$
C. $\frac{\mu \pi^3 N^2 R^2}{3600 t}$
D. $\frac{\mu \pi^3 N^2 R^4}{3600 t}$

Answer: Option B

4. In a footstep bearing, if the speed of the shaft is doubled, then the torque required to overcome the viscous resistance will be
- A. Double
 - B. four times
 - C. eight times
 - D. sixteen times

Answer: Option A

5. The loss of pressure head in case of laminar flow is proportional to
- A. Velocity
 - B. (velocity)²
 - C. (velocity)³
 - D. (velocity)⁴

Answer: Option A

6. The loss of head due to viscosity for laminar flow in pipes is (where d = Diameter of pipe, l = Length of pipe, v = Velocity of the liquid in the pipe, μ = Viscosity of the liquid, and w = Specific weight of the flowing liquid)

- A. $\frac{4\mu v l}{w d^2}$
- B. $\frac{8\mu v l}{w d^2}$
- C. $\frac{16\mu v l}{w d^2}$
- D. $\frac{32\mu v l}{w d^2}$

Answer: Option D

7. In a footstep bearing, if the radius of the shaft is doubled, then the torque required to overcome the viscous resistance will be
- A. Double
 - B. four times
 - C. eight times
 - D. sixteen times

Answer: Option D