

# USE OF MICROBIAL FUEL CELL IN GENERATING ELECTRICITY FROM WASTE MATERIAL

## Abstract

The demand for power is quite significant on a global scale. Microbial Fuel Cell (MFC) Technology may be used to reduce reliance on fossil fuels and to provide alternative sustainable energy sources. MFC Technology uses microorganisms to produce power using the organic matter found in the environment. MFC is a biofuel cell, that generates electricity by converting organic material into electricity. Due to its ability to use wastewater as a substrate and to not require a metal catalyst, it can be taken into consideration as a more sustainable alternative for traditional fuel cells. Waste material are first transformed to chemical energy and then, after being treated to the desired level to electrical energy. An anode, cathode and a separation membrane are the basic components of MFC. MFC technology has the potential to become a more environment friendly fuel cell alternative. Despite being viewed as a promising technology, MFC is not yet commercially viable for usage on a large scale due to its poor current generation per unit cost and high internal resistance. More study should be conducted on the creation of more efficient electrode materials and the development of resilient microorganisms as biocatalysts in order to boost the viability of MFC technology.

**Keywords:** Microbial fuel Cell (MFC), Waste, Wastewater, Microorganisms, Electricity, MFC Technology

## Authors

### Harshika Gupta

Isabella Thoburn College, Uttar Pradesh  
Capital University  
Jharkhand, India  
gharshika663@@gmail.com

### Smita Singh

Isabella Thoburn College, Uttar Pradesh  
Capital University  
Jharkhand, India

### Dr. Maj. Neerja Masih

Isabella Thoburn College, Uttar Pradesh  
Capital University  
Jharkhand, India

## I. INTRODUCTION

Human population on earth is already on the verge of reaching 8 billion and considering the current scenario that shows rapid growth in population, by the second half of the twenty-first century, it is predicted that this number will increase even more and level out. Because of the ambitious social and economic aims, it has become important to worry about the sustainable use and management of natural resources. (A. S. Vishwanathan 2021) In the contemporary world, energy plays a very crucial role. Demand for energy is rising rapidly with increasing population and urbanization. Primarily fossil fuels continue to be a major source of energy, and this causes the depletion of fossil fuel in their reserves. Combustion of fossil fuels also produces large amount of carbon dioxide (CO<sub>2</sub>), which raises the atmospheric concentration of greenhouse gases, ultimately leading to global warming. Over the past ten years, alternative energy sources that are more cost-effective, renewable, and environment friendly have come as a major point of focus for the researchers. (Rustiana Yuliasni et.al., 2021)

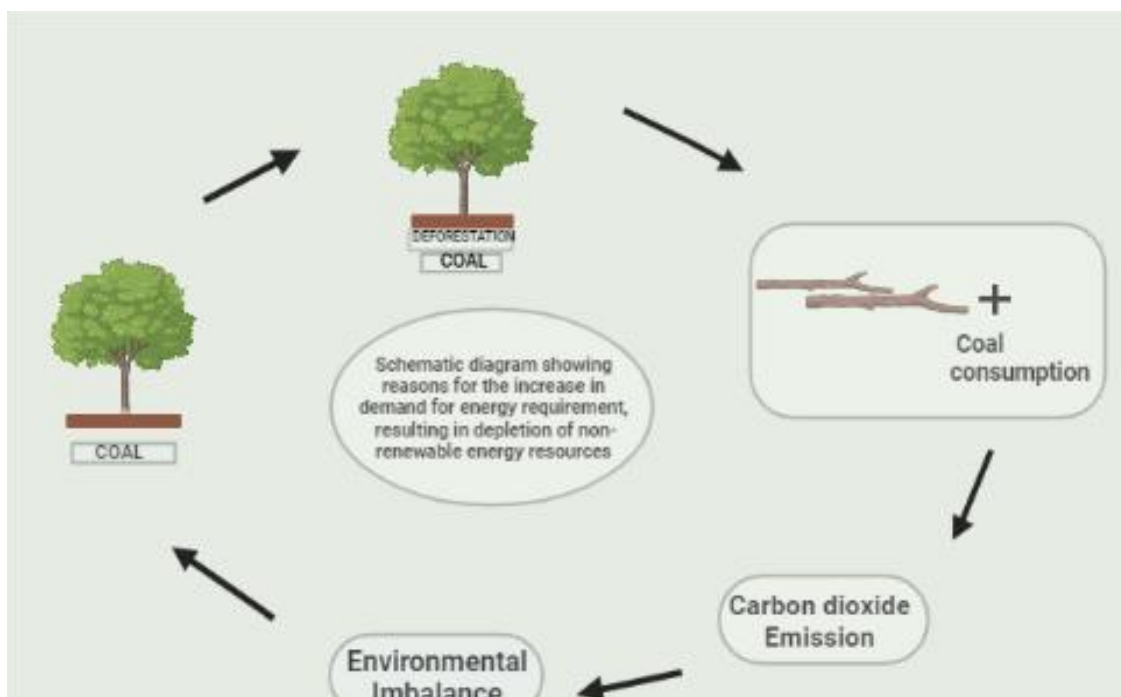

**Figure 1:** Schematic Diagram showing Reasons for the Increase in demand for Energy Requirements, Resulting in Depletion of Non-Renewable Energy Resources

Considering the spontaneous rise in the demand for energy, researchers have come forward to develop a solution for alternative and renewable energy sources, such as MFC Technology. It is a promising technique for energy production that falls under the category of secondary energy production. MFC has the concurrent capacity to treat wastewater and produce electricity at the same time. Additionally, MFCs are seen as an environmentally benign alternative source to fossil fuels. MFC appear to be the answer to our twin issues of rising pollution and declining reliance on fossil fuels. It is a very good alternative energy source that is both highly efficient and economically priced. (A. Sam Sushmitha, Dr. G.L. Sathyamoorthy, 2020) In 1917, researchers used *Escherichia coli* to develop the idea of generating electricity using microorganisms. Since then and till date, MFC technology, which

was first developed in the 1990s, concentrated more on increasing the output of power generation, reducing the costs of operation, and making this technology more useful and sustainable. (Rustiana Yuliasnet.al., 2021) MFCs can use microorganisms as catalysts to oxidise organic matters (mud, food wastes, vegetable wastes, fruit wastes, grass fragments and plant leaves as well) and inorganic substances (non-carbon materials, sulphur compounds, etc.) to generate electricity. Researchers also demonstrated that hydrogen could be created effectively in MFC, which is used to supply electricity to the system and for the purification of water. Since hydrogen remains persistent during both the process of combustion and the electrochemical process for energy combustion, it can reduce or eliminate carbon emissions. (Kasirajan Kasipandian et.al.,2020)

## II. AIM OF THE REVIEW

A Microbial Fuel Cell (MFC) is a bioelectrochemical device that has the ability to generate electricity by the use of electrons obtained by the anaerobic oxidation of substrates. This review mainly focuses on the use of MFC technology using waste material as an alternative source for fossil fuels to fulfil the need of rising energy demands due to the rapidly increasing population.

## III. REVIEW OF LITERATURE

MFC is a system where microbes transform chemical energy from the oxidation of organic and inorganic chemicals into ATP through a series of processes in which electrons are transported to a terminal electron acceptor to produce an electrical current. Anode and cathode components, which are separated by a cationic membrane, make up a conventional MFC. [4] Figure 2 shows the basic working principle of MFC. In an MFC, an ion exchange membrane may or may not be used to separate the anodic and cathodic chambers. Live microorganisms (electroactive microorganisms) oxidise substrates while in a planktonic state or by developing biofilms in the anodic chamber, which leads to the production of electrons, protons, and other metabolites as by products. (Soumya Pandit, 2018) The anode electrons go through the external circuit to the cathode and provide electron acceptors in the cathode region because of the potential difference between the cathode and the anode. (Shuyi Zhou, 2022) On the other side, the protons diffuse to the cathode or percolate through the ion exchange membrane, where they are reduced by the incoming electrons, completing the circuit. Electric current is produced by the flow of electrons through the external load. Water is produced as a by-product as the protons are reduced in the presence of oxygen at the anode, making the process environmentally benign. MFCs come in both big (litre-scale) and tiny sizes (microlitre-scale or millilitre-scale). (Soumya Pandit,2018)

Using glucose as a substrate, following are the reactions:

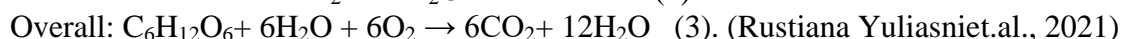
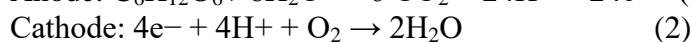
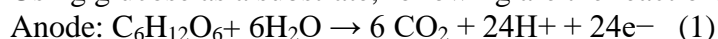

## 1. Essential Components of MFC

**Table 1: Components of MFC**

Components	Materials	Remarks
Anode	Graphite, graphite felt, carbon paper, carbon cloth, Pt, Pt black, etc.	Necessary
Cathode	Graphite, graphite felt, carbon paper, carbon cloth, Pt, Pt black, etc.	Necessary
Anodic Chamber	Glass, polycarbonate, plexigals	Necessary
Cathodic Chamber	Glass, polycarbonate, plexigals	Optional
Proton exchange system	Nafion, Ultrex, Polyethylene	Necessary
Electrode catalyst	Pt, Pt black, polyaniline, etc.	Optional

**Table 1 shows the List of Components of MFC**

- **Electrodes:** The performance of MFCs in terms of bacterial adhesion, electron transfer, and electrochemical efficiency depends greatly on the choice of the appropriate electrode material. Despite the differences between anode and cathode, they should both generally have the following qualities: surface area, porosity, electrical conductivity, stability, durability, cost, and accessibility.
  - **Anode:** Due to their high electrical conductivity, specific surface area, biocompatibility, chemical stability, and affordability, graphite rods are frequently employed as anodes in MFCs.
  - **Cathode:** Following are the characteristics that should be present for a strong MFC cathode: high mechanical strength, catalytic property, high electronic and ionic conductivity. The best cathode is made of graphite rods, however due to its low catalytic activity, an extra catalyst must be added to speed up the reduction process. (Mrs.Xma R.Pote, et.al.,2020)
- **Proton Exchange Membrane (PEM):** Electro-neutrality between the two chambers in MFC technology is a crucial requirement for the PEM's efficient operation, which is made possible by the transport of protons across the membrane. PEM are a crucial part of the MFC assembly because they help to separate the anode and cathode chambers and make it easier for protons to move from the anode to the cathode, where they are needed to maintain the electric current. The following standards make up a PEM's desirable attributes:
 

Cost-effectiveness, enhanced proton conductivity, good segregational qualities, higher mechanical strength, resistance to heat and chemicals, and electronic resistance are among its other qualities. (Akshay D. Tharali, et. al.,2016)
- **Substrates:** Wastewater is an example of organic material that bacteria use as a source of energy. (Al Saned AJ, et.al.,2021)

**Table 2: Substrates along with microorganism used in MFCs**

Wastes Used as Substrates	Microbial Species	Reference
Food wastes	<i>Proteobacteria, Bacteroidetes</i>	[10]
Dairy manure	<i>Clostridium, Pseudomonas</i>	Zhang et.al. (2012)
Swine manure	<i>Clostridium</i>	Vilajeliu-Pons et.al. (2015)
Sewage sludge	<i>Lactobacillus, Flavobacterium</i>	Xiao et.al. (2011)
Food waste leachate	<i>Proteobacteria, Acidobacteria</i>	Li et.al. (2013)
Powder orange peel waste	<i>Chloroflex</i>	Miran et al. (2016)
Aerobic sludge	<i>Nitrospirae, Chlorobi</i>	[7]
Anaerobic sludge	<i>Arcobacter, Geobacter</i>	Wang et.al. (2011)
Wastewater	<i>Shewanella, mixed cultures</i>	Vinay Sharma, Patit Paban Kundu (2010)

Continuous power generation from domestic wastewater is possible. In a single-chambered MFC, it can be seen how most power density is produced utilising swine wastewater as a substrate. Additionally, oil effluent can be used to create bioelectricity. Waste sludge has also been proved to be a successful substrate for the production of hydrogen and bioelectricity together. Microbes isolated from the high Andean region were grown on fruit and vegetable wastes in a single-chambered MFC. Table 2 shows various substrates and their specific microbes used in MFCs.

Food waste leachate from bio-hydrogen fermentation has been used as a viable substrate for improved power generation. Simple substrates like glucose, acetate, propionate, and butyrate have been used in a study to employed in MFCs as substrates for electricity production. Acetate > butyrate > propionate were the substrates for which the power density was assessed. This is especially crucial since the acidogenic decomposition of organic wastes results in a variety of volatile fatty acids depending on their affinity for microorganisms, affect the production of electricity. (Akshay D. Tharali, et. Al.,2016)

- **MFC Specific Microorganisms:** MFC were developed with the goal of producing clean electricity from organic wastes. The most prevalent biocatalysts or microorganisms employed in MFCs are *Shewanella*, *Proteobactor*, and *Pseudomonas* groups. Mixed cultures are most frequently employed in MFCs that utilise waste water. (Vinay Sharma, Patit Paban Kundu, 2010)

Firstly, it's essential to understand some of the major and in depth operations of the bacteria in order to comprehend the basic operations of the MFC. (De Juan et al., 2015)

Earlier, it was believed that just a small number of microbes could be employed to generate electricity in the MFC Technology. In the recent works, it was discovered that MFCs can use the majority of microorganisms. Many microorganisms

are capable of transferring electrons to the anode that are produced through the metabolism of organic and/or inorganic materials. (Yibrah Tekle and Addisu Demeke, 2015)

Microorganisms with the capacity to produce electricity and transmit electrons efficiently in the anode are specifically taken into consideration by the researchers. Such microbes are called Exoelectrogens. Exo refers to “exocellular” and “electrogens” based on their ability to directly transfer electrons to a chemical or material that is not the immediate electron acceptor. (De Juan et al., 2015). These microorganisms are abundant in marine sediment, soil, wastewater, fresh water sediment, and activated sludge. (Yibrah Tekle and Addisu Demeke, 2015)

- 2. Design and Operation:** The formation of Microbial Fuel Cells depends on few key components. Wirings, salt bridges, and electrodes all play an important role in their formation. In a PEM power device or fuel cell, the proton exchange membrane replaces the salt bridge. (Ieropoulos I et al., 2012)

Though the costs rise up, but the handling and power generation both improve and expand. In addition, making the complete system more portable and efficient. Fuel cells can be divided into two categories based on the number of chambers or compartments they have:

- **Single Chambered MFC**
- **Dual Chambered MFC**

Additionally, there is the stacked microbial fuel cell (Jumma S, et al., 2016)

- **Single Chambered MFC:** Single chambered MFCs are available in a variety of designs and can be built in various methods. (Jia J et al., 2013) They are cost effective and simple in design. (Atkar AB, et al., 2017)

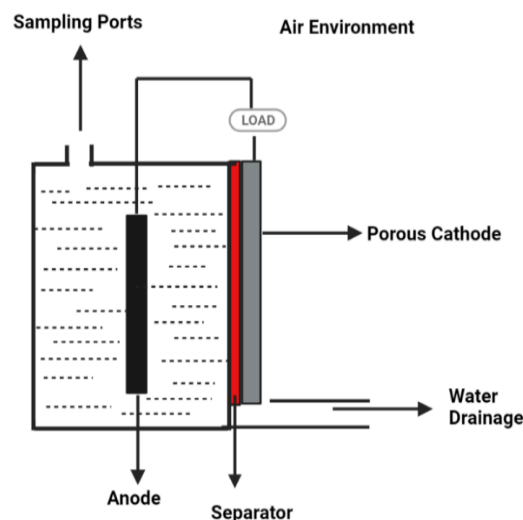
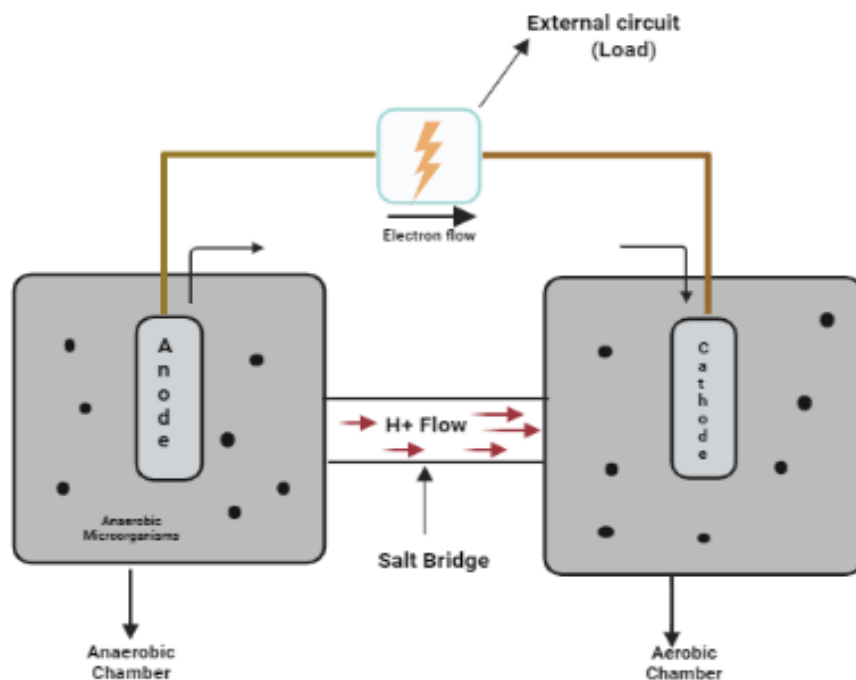

**Figure 3:** Single Chamber MFC: In this model both anode and Cathode Electrode are fixed into the same Chamber and connected by External Wire

In this design, anode and cathode are not separated into different compartments or chambers. (Jia J et al., 2013) They lack a distinct cathode compartment and have a simple anode compartment that may or may not have proton exchange membranes, as shown in Figure 3. (Jumma S, et al., 2016) One side of the cathode chamber is made up of porous cathodes, which consume airborne oxygen and permit protons to diffuse through them. (Jia J et al., 2013) Air cathode can be made up of materials such as graphite, carbon paper, fibres. (Atkar AB, et al., 2017).

Because they are easier to scale up as compared to the double chambered fuel cells, they have currently become an extensive subject of much research interest. The cathodes are either porous carbon electrodes or PEM-bonded with flexible carbon cloth electrodes. Electrolytes are frequently poured steadily into graphite covered cathodes, acting as catholytes to keep the membrane and cathode from drying. In such single chambered microbial fuel cells, water management of better fluid management is a crucial concern. (Jumma S, et al., 2016)

- **Dual Chambered MFC:** Dual chamber MFCs, also known as two compartment MFCs, have two chambers joined by a salt bridge or PEM (as shown in Figure 4 and 5) which allows protons to go in the direction of the cathode chamber. It may prevent oxygen from diffusing into the anode chamber. Due to their intricate construction, dual chamber MFCs are frequently utilised in batch mode and for laboratory research. Scaling up is quite challenging in such designs of fuel cells. (Atkar AB, et al., 2017)



**Figure 4: Two chambered MFC separated by salt bridge**

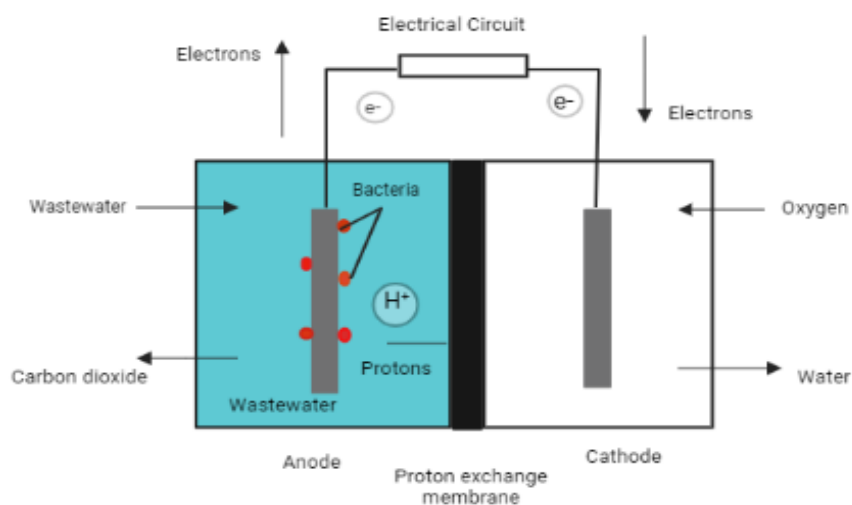

**Figure 5:** Two chambered MFC separated by Proton Exchange Membrane

A variety of materials, including plastic and stainless steel with coating, can be employed in the design and construction of two chambered MFC. The MFC design in Figure 4 is known as the H type because of its shape. Anode chamber and cathode chamber are the names of the two chambers. The electrodes can then be installed in each of the two chambers. Graphite or carbon can be used as the electrode's material. Carbon brush or carbon clothing can be used as an electrode. H-shape frameworks are useful for fundamental parameter analysis, such as investigating force generation using novel materials or the types of microbial communities that arise during the degradation of specific mixes, although they often provide low power densities. The distance between the surfaces of the cathode and the anode, as well as the membrane's surface, have an impact on how much power is generated in these structures.

High internal resistance and cathode-based losses typically place restrictions on the power density  $P$  supplied by these structures. It is advantageous to compare the power generated by various frameworks on the basis of comparably sized anodes, cathodes, and membrane wherever possible. Because a good electron acceptor is available at high fixation, using ferricyanide as the electron acceptor in the cathode chamber increases the force thickness. Ferricyanide compared to an oxygen disintegrating cathode with a Pt catalyst, the force was increased by 1.5 to 1.8 times. (Jia J et al., 2013)

PEM or salt bridges serve primarily as a proton transfer medium to complete the circuit, as indicated in the Figure 4 and 5. In addition to finishing the reaction, this keeps the anode from coming into touch with oxygen or any other oxidizers. They operate in batches, have a larger power output, and can be used to provide power in very difficult circumstances.

It might be scaled up to treat vast volumes of wastewater and other carbon sources. They essentially fall into the single- and double-chamber categories for microbial fuel cells. They lack mediators, occasionally lack membranes, and can be utilised to produce electricity on a huge scale from trash. (Jumma S, et al., 2016)



- **Stacked MFCs:** Stack MFCs are MFCs that are coupled in series or parallel to increase output voltage or current. (Atkar AB, et al.,2017) This kind of development doesn't affect each cell's individual Coulombic proficiency, but when combined, it increases the overall battery's yield to be comparable to conventional power sources, as shown in figure 6. (Jia J et al., 2013)

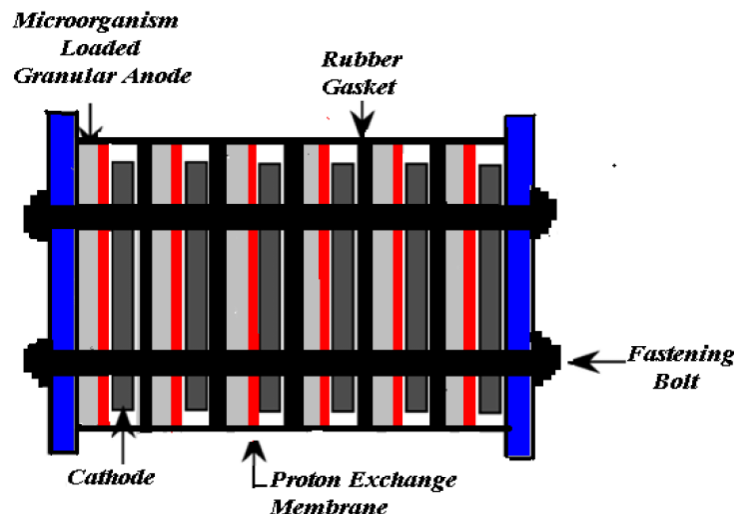

**Figure 6:** Schematic design of Stacked type Microbial Fuel Cell

There are two different kinds of stack MFCs: one type is the parallel type, and the other is the series type. When operated at the same volumetric flow rate, the parallel connection is six times more efficient than the series connection. The parallel type of stack MFCs have a faster rate of chemical reaction than the series type of stack MFCs. Consequently, parallel-type MFCs are employed to eliminate wastewater's COD (Chemical Oxygen Demand), which can deliver electrons to the anode directly. (Atkar AB, et al.,2017)

- **Up-Flow Microbial Fuel Cell:** The tubular-shaped MFC is composed of layers of glass beads, a glass wall separator, a cathode, and an anode (top and bottom). Food is delivered from below the anode, crosses the cathode, and then travels upward. The diffusion barrier positioned between electrodes creates the gradient necessary for MFCs to function properly. [2] They essentially fall into the single- and double-chamber categories for microbial fuel cells. They lack mediators, occasionally lack membranes, and can be utilised to produce electricity on a huge scale from trash. (Jumma S, et al., 2016)
- **Other Designs:** Most MFC researches use the basic pre-existing designs, and less attention is given to creating new designs that address the shortcomings of the present designs. A flat-plate MFC (FPMFC) was introduced in 2004 to lessen one barrier, it was created to lessen the ohmic resistance brought on a wider interelectrode spacing. This style of design is typically employed in chemical fuel cells, where it also yields greater power generation than the earlier designs. The anode and the cathode in the FPMFC were constructed from flat plates, each with a projected surface area of 225 cm<sup>2</sup>. (Min and Logan, 2004)

Between the two plates was a Nafion membrane. With residential wastewater as a substrate, this reactor produced a power density of 56 mW/m<sup>2</sup>, and 58% COD was attained in the study. Although the reactor produced less power than the other designs, such as the cube reactor, it was also utilised to generate power from different substrates, such as acetate, glucose, starch, etc. It might be because the electrodes are attached too tightly together, allowing oxygen to get through the membrane to the bacteria in the anode chamber and hinder the microbial community's ability to flourish. (Ravinder Kumar, et.al.,2017)

### 3. Applications of MFC

- **Electricity Generation:** It is clear that the majority of research on MFCs is done for the purpose of producing energy, which is the foremost application of this technology. Table 3 shows Performance of MFCs for Bioelectricity Generation.

**Table 3: Performance of MFCs for Bioelectricity Generation (Ravinder Kumar, et.al. , 2017)**

Types of MFC	Substrate	Power Density
Single Chambered MFC	Glucose	68 mW/m <sup>2</sup>
	Acetic Acid	835 mW/m <sup>2</sup>
	Ethanol	820mW/m <sup>2</sup>
	Domestic waste water	114mW/m <sup>2</sup>
Double Chambered MFC	Glucose	855mW/m <sup>2</sup>
	Acetate	1926mW/m <sup>2</sup>
	Acetate	1.9Mw/m <sup>2</sup>
	Cellulose	188mW/m <sup>2</sup>
	Wastewater	2485mW/m <sup>2</sup>

The microorganisms in the MFC's anode chamber oxidise the substrate to produce protons and electrons, which are then transferred to the cathode via electrical connection and PEM, respectively. To detect the voltage and calculate the power using Ohm's law, the two chambers of the MFC can be electrically connected to a multimeter and an external resistor box. To increase coulombic efficiency and subsequently the MFCs' power production, it is crucial to use substrates that can totally oxidise into electrons in MFCs. According to a study, *Geobacter sulfurreducens* may entirely convert acetate into electrons and protons. (Ravinder Kumar, et.al.,2017)

To increase outputs, electrodes are changed with metal catalyst, nanoparticles, and chemicals. Additionally, the cathode is altered to switch out the expensive platinum catalyst for a less expensive one with equivalent qualities. According to the study, these adjustments reduce the system's internal resistance and startup time. To improve the output performance, the anode is modified using nitrogen-doped electrodes, heat-treated electrodes, gold nanoparticles, graphene, and carbon nanotubes, for example, CNT-gold-titanium nanocomposites improve MFC performance.

Nitrogen-doped carbon nanoparticles placed on carbon cloth electrodes are used to strengthen the Extracellular Electron Transfer (EET) mechanism. The two-chambered MFC is inoculated with *Shewanella oneidensis* MR-1. By absorbing the flavins the organism secretes, it boosts the rate of electron transmission and power density. According to studies, the anode is dusted with CNT powder, which promotes the growth of the *G. sulfurreducens* biofilm and lowers internal resistance and startup time. Bacteria are more likely to stick to the electrode because of the faster startup time. In comparison to the simple carbon cloth anode, the carbon nanotube anode in the double-chambered MFC boosts the power density up to four times. It has been hypothesised that *Shewanella's* outer membrane c-type cytochromes exhibit a strong affinity for ferric oxide. The addition of iron oxide to electrodes promotes the EET mechanism and metabolism of the biofilm while also promoting bacterial growth. (Quratulain Maqsood, et.al., 2021)

- Waste Water Treatment:** The ability of the MFCs to treat various industrial, urban, or home wastewaters has been potentially observed. Table 4 provides several illustrations of MFC performance for wastewater treatment. Although MFCs are unable to entirely treat the extremely toxic wastewaters, they can significantly lower the Chemical Oxygen Demand (COD) of the wastewaters to fulfil discharge requirements before they are released into the environment. The MFCs have shown to remove up to 98% of COD from wastewater. As an alternative, wastewaters rich in organic substances (such as proteins, lipids, minerals, fatty acids, and carbohydrates) serve as the substrate for microbial metabolism, which in turn generates electrons and protons.

Moreover, inoculum can be found in wastewaters. Before and after the MFC operation, the treatment effectiveness of the MFCs can be assessed using the standard wastewater treatment assays (COD, Biological Oxygen Demand (BOD), total solids, and nitrogen removal). By running the MFCs under ideal circumstances, such as mesophilic temperatures, which have been shown to increase the COD removal, the COD removal in MFCs can be further enhanced. Additionally, the MFC's fed-batch mode operation is beneficial for achieving high COD removal rates. The coulombic efficiency obtained in such cases is quite low, ranging from 10% to 30% only. Typically, MFC studies operated for wastewater treatment are coupled with power generation. (Ravinder Kumar, et.al., 2017)

**Table 4: Performance of MFCs for Wastewater treatment/ Bioremediation (Ravinder Kumar, et.al.)**

Types of MFC	Wastewater/Heavy Metals	% COD Removal
Single Chambered MFC	Olive mill wastewater	65
	Biodiesel Wastes	90
	Chromium (VI)	99
	Azo dye Congo Red	98
	Cadmium	90

Double Chambered MFC	Domestic wastewater	88
	Chemical wastewater	63
	Real urban wastewater	70
	Food waste leachate	85
	Cyanide	88

Additionally, several pre-treatment techniques can improve MFC performance. For instance, autoclaving kills the methanogens that use the organic components of wastewater to produce methane. Autoclaving was found to boost power density by 5%. Sonication, on the other hand, was employed to treat untreated wastewater. It boosted COD removal by 5% and power density by 16%. Furthermore, using a stirring approach, COD can be eliminated from wastewater. These pre-treatment methods boost energy production, but they cannot be scaled up. (Quratulain Maqsood, et.al. 2021)

The use of MFC technology for wastewater biotreatment has shown excellent conversion of organic matter in wastewater into electricity with decrease in COD and BOD of 40-90%. (Oji, et. Al.,2012) Wastewater with a high COD value increases the power density of MFC. However, when the substrate concentration is high, it results in electrode fouling, which restricts flow and causes an accumulation of salts and precipitates. Furthermore, the cathode has less proton availability. Because of this clogging, wastewater dilutions are utilised to control how well the MFCs work.

- **Biosensors:** MFC technology is used as a biosensor to detect pollutants in water, in addition to producing power and treating wastewater. MFC is designated as a BOD sensor due to the linear relationship between the coulombic yield of the material and wastewater strength. The MFC-based biosensor is superior to traditional biosensors in some ways. Because they do not require a transducer, which is typically utilised in conventional biosensors, these biosensors are relatively less expensive. Additionally, they can run for a very long time—up to 5 years—without any maintenance. MFC-based biosensors are therefore more stable and reliable. Numerous studies have demonstrated that vast BOD ranges (low/high) can be monitored in MFC-based biosensors on the basis of linear correlation. (Ravinder Kumar, et.al., 2017 & Oji, et. Al.,2012)

The detection of organic matter in wastewater to examine the performance of MFC as biosensors. They made two MFC using two different Proton exchange membranes—MFC1 using Nafion and MFC2 using inexpensive clayware—and they investigated how they affected the performance of the MFC as a biosensor. (Sumaraj et al.)

The researchers found that MFC1 performs better and responds more quickly to low COD concentrations between 22 mg L<sup>-1</sup> and 51 mg L<sup>-1</sup>. MFC2 can detect concentrations up to 212 mg L<sup>-1</sup>, but only as high as 67 mg L<sup>-1</sup>. Both of the MFCs had different reaction times. While MFC2 perceived the concentration at 310 min, MFC1 responded swiftly with sensing times of 210 min and 120 min. They suggested that the PEM employed is the source of the variance in findings by both MFC. Proton conductivity (PC) and membrane thickness are responsible for the change.

While Clayware (CWPEM) is 17 times thicker than NPEM, Nafion has 40 times more PC than CWPEM. They came to the conclusion that, while taking into account the device's economics, low-cost clayware PEM might be employed in MFC for BOD monitoring. Although Nafion performs better, it costs 400 cm<sup>2</sup> more than clayware, which costs 0.4 cm<sup>2</sup>. (Abhishek J.et.al., 2019)

- **Biohydrogen:** A microbial electrolysis cell (MEC) can be modified from a normal double-chamber MFC to produce hydrogen. The fundamental workings of a MEC remain essentially the same; however, electric current is now supplied to the cathodic chamber. The anode and the cathode are the other two chambers that make up a MEC. Similar to MFC, an ion exchange membrane divides the MEC's two chambers.

Exoelectrogens metabolise the substrate and generate electrons and protons in the anode chamber. In MFCs, the protons are transported to the cathode similarly. At the cathode, however, a reaction between protons and electrons that would make hydrogen is thermodynamically impossible. At the cathode, electric current is applied to cause this reaction.

Most of the time, >0.3 V is sufficient to meet the electrical need. The MFCs can readily provide such low voltages. In order to meet the electrical demand, the MFCs used to create power can be paired with MEC. As shown in Figure 9. It is simple to store the hydrogen created by the MEC, which can then be utilised to generate energy. (Ravinder Kumar, et.al., 2017 & Jhansi L. Varanasi et.al., 2019)

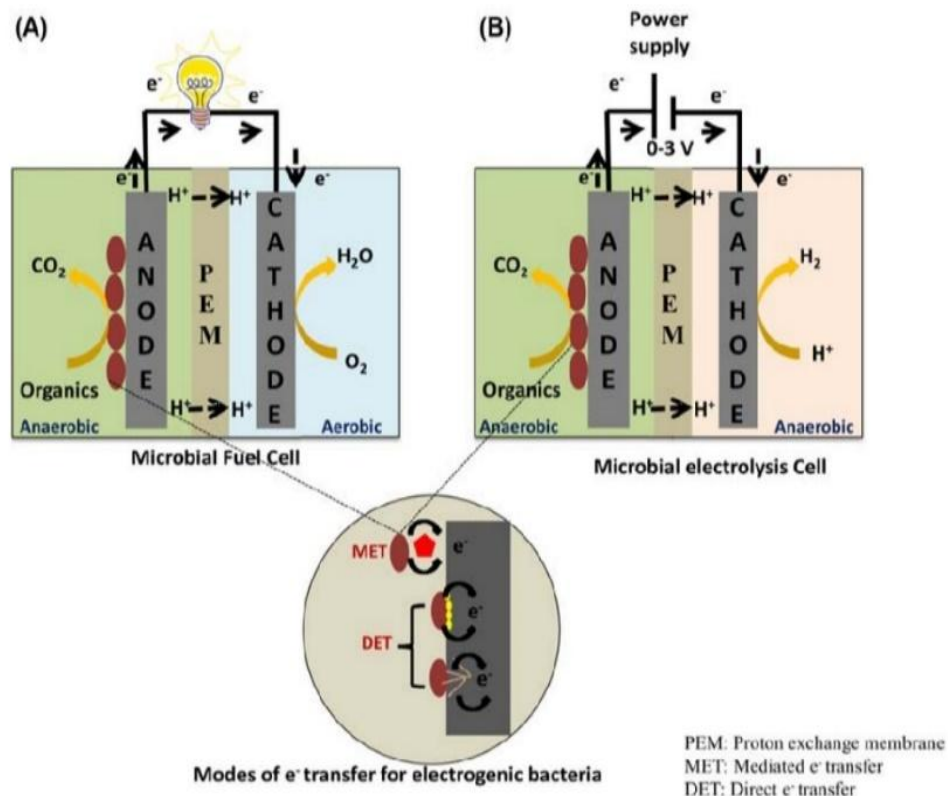

**Figure 7:** Schematic of the working principles of (A) microbial fuel cell and (B) Microbial electrolysis cell (Jhansi L. Varanasi et.al., 2019)

#### 4. Factors Affecting the MFC Performance

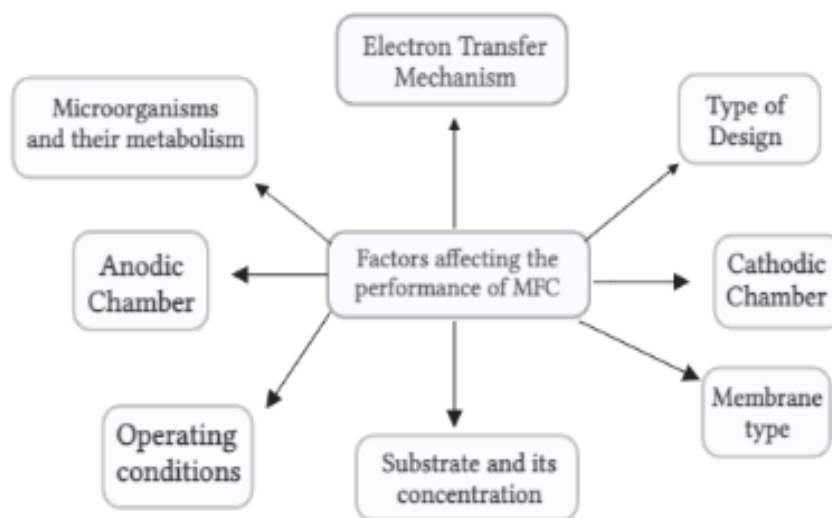

**Figure 8:** Factors Affecting MFC's Performance

- **Electron Transfer Mechanism:** Shuttles or electron mediators should be used to convey the generated electrons from the anodic chamber to the anode. Certain microorganisms, including some *Saccharomyces* species and *E. coli* strains used in MFCs, have an outer layer of non-conductive lipid membrane that contains peptidoglycans and lipopolysaccharides that slow down the direct electron transfer to the anode. The mediators are usually coloured substances, such as humic acid, neutral red, thionine, methylene blue, or methyl viologen. (Shanmuganathan. P et.al.,2018)

The ability to penetrate the bacterial membrane and contact the reductive species inside the bacterium, where they are reduced during microbial metabolism, are only a few of the qualities mediators must possess. The mediator's redox potential should match that of the reductive metabolite.

The mediator must not interact with any other metabolites produced by the bacteria. Reduced mediators must be easily transported from the cell to the anode, where they may undergo oxidation. Fast electrochemical kinetics are required for the mediator-reduced state oxidation process at the electrode surface. (Chetan Pandit, et.al.,2022)

- **Microbial Metabolism and Cell Potential:** The primary factor in determining the cell potential is the metabolic route of the microorganism and the subsequent potential of the anode. In MFCs, the rate-limiting phase is bacterial catabolism. The oxidation of organic substances provides energy for heterotrophic organisms. The respiratory chain and fermentation are two key metabolic pathways taking place in the anodic chamber as a result of the participation of exogenous oxidants, or external terminal electron acceptors.

The potential differences between the cathode and the anode determine the electrical potential of the MFC. (Shanmuganathan. P,et.al.,2018) Through the

respiratory chain, the substrate is oxidised, releasing electrons that go to an externally reachable terminal electron acceptor through a redox cascade. An organism gains more energy, the higher the positive redox potential of a terminal electron acceptor with a given substrate, or electron donor. (Chetan Pandit, et.al.,2022)

- **Substrate Concentration:** Substrates used in MFCs come in a wide range from straightforward chemicals to intricate organic combinations. Pure substrates like glucose, acetate, butyrate, lactate, proteins, cellulose, cysteine, glycine, and glycerol have occasionally been employed. (Shanmuganathan. P, et.al.,2018)

Wastewater is one of the many substrates that MFCs may process and is a medium with many resources. Several studies on the direct generation of electricity from complex organic wastewater, including municipal, swine, dairy, slaughterhouse, rice mill, tannery, cassava mill, molasses wastewater, refinery, brewery, winery, chemical wastewater, sulfide-rich wastewater, landfill leachate, food waste leachate, azo dye, and solid substrates like rice straw have been published. MFCs can also simultaneously extract nitrate and sulphide from sulfate-sulfide-rich wastewaters and synthetic effluent. (Chetan Pandit, et.al.,2022) MFC should be operated with the highest level of concentration possible to generate the most electricity possible. (Maksudur R. Khan,et.al.,2013)

- **Anode:** The electrode at which electrons leave the cell and oxidation takes place is known as the anode, and the electrode at which electrons enter the cell and reduction takes place is known as the cathode.

The crucial properties of anode material are conductivity, stability, biocompatibility, non-corrosive manner, and surface area. Additionally, the MFC's architecture and electrode fabrication process have an impact on how well it performs. Despite having strong conductivity, bacteria cannot tolerate copper, making it an unsuitable material for an anode. Although it has a lower conductivity for moving electrons, carbon is a better electrode material for bacterial adhesion. It comes in carbon felt, fabric, foam, paper, and fibre forms. Anode materials have a considerable impact on the performance and price of MFCs, which contributes to their effectiveness. (Chetan Pandit, et.al.,2022)

Excellent electrical conductivity, a sizable surface area, and good biocompatibility for bacterial colonisation are ideal characteristics for an anode in an MFC. The microorganisms in the anode chamber, which has anaerobic conditions, produce gas that should quickly exit the system to prevent the anode chamber from building up pressure. Therefore, the requirement for a high bed void fraction is crucial. Another element is the device that directly transfers electrons from the anode to the bacterium, which is what produces the majority of the power. Therefore, increasing the anode's physical contact with bacteria is beneficial for MFCs' ability to generate power. (Shanmuganathan. P et.al.,2018)

- **Cathode:** The biggest obstacle to an MFC being a practical and scalable technology is the cathode design. At the cathode contact, the oxygen reduction reaction (ORR) depletes the oxygen and produces either water or hydrogen peroxide. Due to the

functioning MFC's neutral pH and ambient operating temperature, its ORR is constrained in comparison to chemical fuel cells. The cathode materials, which must have a high redox potential to take the electrons, have a significant impact on the performance of an MFC. Graphite, carbon cloth, and commercially available carbon paper are the most often utilised materials for cathodes. However, unless metal catalysts are utilised, it is challenging to achieve high cathodic potentials. (Shanmuganathan. P et.al.,2018 & Chetan Pandit et.al.,2022)

- **Operating Conditions:** The most crucial elements for bacterial growth that impact MFC effectiveness are temperature, pH, ionic strength, and salinity. The general reaction environment for MFCs is mild, including room temperature, normal pressure, and neutral pH. (Shanmuganathan. P et.al.,2018 & Chetan Pandit et.al.,2022)

#### IV. RECENT ADVANCEMENT

**Integrating Human Waste In Microbial Fuel Cell Technology:** The development of MFC technology towards commercialisation has been facilitated by a number of scientific and technological advances over the past 100 years of research. Given the current level of MFC research, the low power output and associated high manufacturing costs of this technology restrict its use in the field. An appropriate and practical approach for long-term sanitation to address the inadequate treatment effectiveness of the CST system now in use may be field deployment of MFC. Additionally, it is possible to think of human waste (excreta and urine) as a sustainable golden gold (substrate) that may be used in MFC to capture energy during effective wastewater treatment while also recovering by-products (Figure 9) and promoting the reuse of treated water.

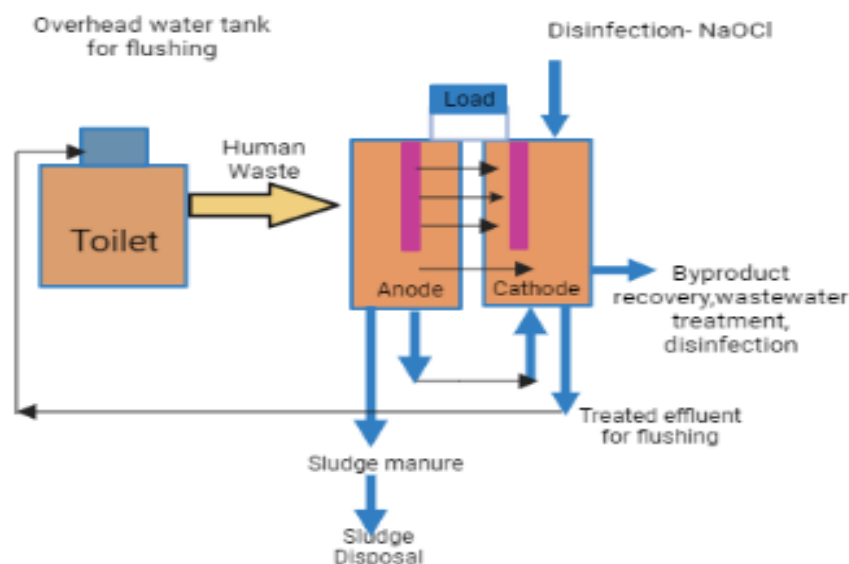

**Figure 9:** Schematic diagram showing the integration of Human waste in MFC technology

Such an environmentally benign bio-electrochemical system is promoted as an independent and renewable energy source from sustainable sanitation, environmental issues, and public health. Similar to sediment MFCs, septic tank systems must be modified to work



with contemporary bio-electrochemical systems for field applications of MFCs for sanitation to be viable and practical. (Chetan Pandit, et.al.,2022)

As a result, this recently found bioelectrochemical technique may turn out to be an effective substitute for long-term sanitation and bioenergy recovery. Such bioelectric toilet (BET) technology may effectively remove organic matter, nutrients, sulphur, effluent disinfection, efficiently degrade faecal sludge, remove odours, and recover precious resources while also producing electricity to power LED lights, biosensors, and other electronic devices. (Chetan Pandit, et.al.,2022) MFCs' disposal of human waste may purify toilet waste and generate electricity. In order to extract potential energy from human waste, built an eLatrine MFC using inexpensive corrugated cardboard as an electrode material and human excrement as a substrate. A low open-circuit voltage of 200 mV was achieved by Perlow's initial study on the microbial oxidation of MFC waste.

A dual-chamber MFC that processed real human waste eliminated 71% of the total chemical oxygen demand (TCOD), 88.1% of the soluble COD, and 44% of the  $\text{NH}_4^+$  while generating 70.8 mW/m<sup>2</sup> of energy.

During wastewater treatment at a septic tank, three units of air cathode column MFCs were coupled in a stack configuration, yielding a power density of 142 6.71 mW/m<sup>2</sup>. Recent research using septage wastewater in a 20 L MFC produced 99.8%, 86.4%, and 82.8 percent removal efficiency for total suspended solids (TSS), biochemical oxygen demand (BOD), and nitrate when operating at 1000 ohms. (Leton et al.,2016 ) *Pseudomonas otitidis* AATB4 bacteria, which was isolated from septic tank effluent, had a coulombic efficiency (CE) of 15% and a current density of 800 mA/m<sup>2</sup> in a plexiglass MFC . Thus, there have been some major attempts to extract energy from human waste, but the scaling up of such MFCs is hampered by their poor power output.

Faecal sludge is a semisolid slurry that is generated during the collection, storage, or treatment of human excreta and black water, which degrades more slowly than human excreta. The chemical energy contained in faecal sludge or activated sludge organic matter may be bio-electrochemically converted into electrical energy using MFC technology. Faecal matter was used as the substrate in the experiment to achieve an operating voltage of 0.45-0.65 V with a CE of 1.5-4.3 percent. Additionally, faecal sludge's microbial population can be used as an electrogenic inoculum, negating the necessity for external seeding at MFC beginning.

The chemical energy included in urine can be recovered as electricity in MFC or as hydrogen gas during electrolysis in microbial electrolysis cells (MECs) by applying an external potential. Recent improvements in microbial electrochemical systems have made MFC/MECs capable of offering a novel method for treating urine. Recently, a urine waste-to-energy method for making bioelectricity in MFCs was reported, and work is still being done on real-world applications to charge mobile phone batteries with stacked MFC units. Utilizing a three-stage integrated MFC system, reported a novel technique for recovering struvite and producing energy from human urine. Actual and synthetic urine were employed in an MFC to achieve ammonium recovery and concurrent energy recovery. (Kuntke et al., 2012)

Additionally tested fake urine in a 1 mL MFC and found that it produced 962.94 mW/m<sup>3</sup> of net power. In field testing of a Pee power urinal in 2016, and achieved a maximum power of 800 mW and a COD elimination effectiveness of over 95% when the light was connected directly to roughly 432 MFC units. The application of MFCs for concurrent power harvesting and direct urine treatment was shown in this first field test of an MFC system for urinal wastewater. Since that time, MFC for ammonia recovery has used urine as a common substrate. (Ghangrekar MM et al.,2008)

## V. CHALLENGES AND FUTURE PROSPECTS

In order to limit the losses caused by activation, ohmic, and concentration overpotentials, it is necessary to discuss low power densities in MFC operation. Additionally, losses that are caused by reaction processes that are not required or microbial metabolic reactions should be enmarked as they do not benefit the process.

It is also necessary to target any microbial metabolic reactions or anodic chamber reactions that are detrimental to the process. On the other hand, it is necessary to increase system volumetric capacity while minimising internal energy losses. To avoid catastrophic losses in this direction, stacking MFCs is a typical option.

Additionally, tubular and other layered techniques are also being researched. Additionally, taking action is necessary to increase the exoelectrogenic microbial population density, which appears to be constrained for reasons other than the availability of attachment positions on the electrode surface. This population density may be increased by bioaugmentation and may be influenced by potential field effects that may exist in the electrode due to its advantageous morphology and conductivity.

By modifying electrode surfaces and covering them with active catalysts, ongoing efforts are being undertaken to create improved e transfer mechanisms between the electrode and the biocatalyst.

## VI. CONCLUSION

This review provided the background for use of MFC technology, substrates as waste materials used as fuel from variety of sources, designs of MFC and its applications. MFC is a considerable source of renewable energy. This sustainable approach of employing MFCs can replace the pollution caused by industrialization and over exploitation of fossil fuels. It has various uses in power generation and wastewater treatment. This system has drawn attention due to its effective utilisation of organic wastes to generate electricity. It can be a promising alternative source for electricity generation when using biofuel in place of fossil fuel. Other than power generation and wastewater treatment MFCs can be used as biosensors, in the production of Biohydrogen, etc. As every subject has its own advantages and drawbacks, MFCs too have their share of some obstacles alongside their applications. The rate of energy production is still not feasible enough to be taken into consideration for being used on practical scale. This is because of the high costs of material used in components of MFC. In future certain required changes such as modification in designs, materials of electrodes, etc should be taken in consideration to make this technology more feasible in practical approach.

**REFERENCES**

- [1] Abul A. Microbial fuel cells: design, control-oriented modeling, and experimental results. Michigan State University; 2015.
- [2] Al-saned AJ, Kitafa BA, Badday AS. Microbial fuel cells (MFC) in the treatment of dairy wastewater. InIOP Conference Series: Materials Science and Engineering 2021 Feb 1 (Vol. 1067, No. 1, p. 012073). IOP Publishing.
- [3] Atkar AB, Raut SA, Goswami AK, Bajad GS. A review on microbial fuel cell, Department of Chemical Engineering. University Institute of Chemical Technology (UICET), North Maharashtra University, international conference proceeding ICGTETM Dec 2017 |ISSN: 2320-2882 IJCRT Publish Paper.
- [4] Chaturvedi V, Verma P. Microbial fuel cell: a green approach for the utilization of waste for the generation of bioelectricity. *Bioresources and Bioprocessing*. 2016 Dec;3:1-4.
- [5] Chhazed AJ, Makwana MV, Chavda NK. Microbial fuel cell functioning, developments and applications-a review. *Int J Sci Res*. 2019 Dec;8(12):3620-33.
- [6] De Juan A, Nixon B. Technical evaluation of the microbial fuel cell technology in wastewater applications. *J. Sustain. Energy Eng*. 2015;1:1-8.
- [7] Gao C, Wang A, Wu WM, Yin Y, Zhao YG. Enrichment of anodic biofilm inoculated with anaerobic or aerobic sludge in single chambered air-cathode microbial fuel cells. *Bioresource technology*. 2014 Sep 1;167:124-32.
- [8] Ieropoulos I, Greenman J, Melhuish C. Urine utilisation by microbial fuel cells; energy fuel for the future. *Physical Chemistry Chemical Physics*. 2012;14(1):94-8.
- [9] Jadhav DA, Ghangrekar MM. Optimising the proportion of pure and mixed culture in inoculum to enhance the performance of microbial fuel cells. *International Journal of Environmental Technology and Management*. 2020;23(1):50-67.
- [10] Jia J, Tang Y, Liu B, Wu D, Ren N, Xing D. Electricity generation from food wastes and microbial community structure in microbial fuel cells. *Bioresource technology*. 2013 Sep 1;144:94-9.
- [11] Jumma S, Patil N, Pandhre R. Microbial Fuel Cell: Design and Operation. *Research and Reviews: Journal of Microbiology and Biotechnology*. 2016;2016:1-8.
- [12] Karmakar S, Kundu K, Kundu S. Design and development of microbial fuel cells. *Curr Res Technol Educ Top Appl Microbiol Microb Biotechnol*. 2010:1029-34.
- [13] Kasipandian K, Saigeetha S, Samrot AV, Abirami S, Renitta RE, Dhiva S. Bioelectricity Production Using Microbial Fuel Cell–.
- [14] Kumar R, Singh L, Zularisam AW. Microbial fuel cells: Types and applications. *Waste biomass management–A holistic approach*. 2017:367-84.
- [15] Kuntke P, Śmiech K, Bruning H, Zeeman G, Saakes M, Sleutels TH, Hamelers HV, Buisman CJ. Ammonium recovery and energy production from urine by a microbial fuel cell. *Water research*. 2012 May 15;46(8):2627-36.
- [16] Leton TG, Yusuf M, Akatah BM. Utilization of multistage microbial fuel cell for septic wastewater treatment. *J Mech Civ Eng*. 2016;13:80-6.
- [17] Li XM, Cheng KY, Selvam A, Wong JW. Bioelectricity production from acidic food waste leachate using microbial fuel cells: effect of microbial inocula. *Process Biochemistry*. 2013 Feb 1;48(2):283-8.
- [18] Maksudur R. Khan,M.S.A. Amin,M.T. Rahman ,F. Akbar AndK. Ferdous Published Online: 27 Mar 2013 Volume & Issue: Volume 15 (2013) – Issue 1 (March 2013)
- [19] Maqsood Q, Ameen E, Mahnoor M, Sumrin A, Akhtar MW, Bhattacharya R, Bose D. Applications of Microbial Fuel Cell Technology and Strategies to Boost Bioreactor Performance. *Nature Environment & Pollution Technology*. 2022 Sep 1;21(3).
- [20] Min B, Logan BE. Continuous electricity generation from domestic wastewater and organic substrates in a flat plate microbial fuel cell. *Environmental science & technology*. 2004 Nov 1;38(21):5809-14.
- [21] Miran W, Nawaz M, Jang J, Lee DS. Conversion of orange peel waste biomass to bioelectricity using a mediator-less microbial fuel cell. *Science of the Total Environment*. 2016 Mar 15;547:197-205.
- [22] Mohan SV, Pandey A, Varjani S, editors. Biomass, biofuels, biochemicals: Microbial electrochemical technology: Sustainable platform for fuels, chemicals and remediation. Elsevier; 2018 Sep 28.
- [23] Oji A, Opara CC, Oduola MK. Fundamentals and field application of microbial fuel cells (MFCs). *Euro. J. Appl. Eng. Sci. Res*. 2012;1(4):185-9.
- [24] Pandit C, Thapa BS, Srivastava B, Mathuriya AS, Toor UA, Pant M, Pandit S, Jadhav DA. Integrating Human Waste with Microbial Fuel Cells to Elevate the Production of Bioelectricity. *BioTech*. 2022 Aug 22;11(3):36.

- [25] Pandit S, Das D. Principles of microbial fuel cell for the power generation. *Microbial fuel cell: A bioelectrochemical system that converts waste to watts*. 2018:21-41.
- [26] Pote MX, Kurhade MS. A Review of Microbial Fuel Cell Technology and its applications.
- [27] PROF SANTRA SC Dr. Anusaya Mallick, Mr. Saurabh Bharti, and Sourav Banerjee ENVIS centre, department of environmental science University of Kalyani. Vol. 25 ISSN: 0974-2476; DECEMBER 2014.
- [28] RustianaYuliasni AK, Setianingsih NI, Sushmitha aS, Dr. Sathyamoorthy GL. 2020;9(3, March).
- [29] Shanmuganathan P, Rajasulochana. FACTORS AFFECTING THE PERFORMANCE OF MICROBIAL FUEL CELLS Corresponding Author, Bharath University, Agaram main road, Selaiyur, Chennai. *Int J Mech Eng Technol (IJMET)*. 2018;9(9, September).
- [30] Sharma V, Kundu PP. Biocatalysts in microbial fuel cells. *Enzyme and microbial technology*. 2010 Oct 6;47(5):179-88.
- [31] Sumaraj GM, Ghangrekar M. Influence of proton exchange membrane and oxidant in development of microbial fuel cell for detection of organic matter in wastewater.
- [32] Sushmitha AS, Sathyamoorthy G.L. A review on green energy production using microbial fuel cell (MFC) technology 2020 Mar 3
- [33] Tekle Y, Demeke A. Review on microbial fuel cell. *Basic Research Journal of Microbiology*. 2015 Nov;2(1):5.
- [34] Tharali AD, Sain N, Osborne WJ. Microbial fuel cells in bioelectricity production. *Frontiers in life science*. 2016 Oct 1;9(4):252-66.
- [35] Thulasinathan B, Nainamohamed S, Samuel JO, Soorangkattan S, Muthuramalingam J, Kulanthaisamy M, Balasubramani R, Nguyen DD, Chang SW, Bolan N, Tsang YF. Comparative study on *Cronobacter sakazakii* and *Pseudomonas otitidis* isolated from septic tank wastewater in microbial fuel cell for bioelectricity generation. *Fuel*. 2019 Jul 15;248:47-55.
- [36] Varanasi JL, Veerubhotla R, Pandit S, Das D. Biohydrogen production using microbial electrolysis cell: recent advances and future prospects. *Microbial electrochemical technology*. 2019 Jan 1:843-69.
- [37] Vilajeliu-Pons A, Puig S, Pous N, Salcedo-Dávila I, Bañeras L, Balaguer MD, Colprim J. Microbiome characterization of MFCs used for the treatment of swine manure. *Journal of Hazardous Materials*. 2015 May 15;288:60-8.
- [38] Vishwanathan AS. Microbial fuel cells: a comprehensive review for beginners. *3 Biotech*. 2021 May;11(5):248. Doi: 10.1007/s13205-021-02802-y. Epub 2021 May 1. PMID: 33968591; PMCID: PMC8088421.
- [39] Vogl A, Bischof F, Wichern M. Single chamber microbial fuel cells for high strength wastewater and blackwater treatment—A comparison of idealized wastewater, synthetic human blackwater, and diluted pig manure. *Biochemical engineering journal*. 2016 Nov 15;115:64-71.
- [40] Wang L, Ma J, Liu TZ, Li CM, Zhang HY. Efficacy of ferrate oxidation and hydrolyze remnant activated sludge. *Huan Jing ke Xue= Huanjing Kexue*. 2011 Jul 1;32(7):2019-22.
- [41] Xiao B, Yang F, Liu J. Enhancing simultaneous electricity production and reduction of sewage sludge in two-chamber MFC by aerobic sludge digestion and sludge pretreatments. *Journal of hazardous materials*. 2011 May 15;189(1-2):444-9.
- [42] Yazdi H, Alzate-Gaviria L, Ren ZJ. Pluggable microbial fuel cell stacks for septic wastewater treatment and electricity production. *Bioresource technology*. 2015 Mar 1;180:258-63.
- [43] Yuliasni R, Kadier A, Setianingsih NI, Wang J, Hariastuti N, Ma PC. Introduction to Microbial Fuel Cell (MFC): Waste Matter to Electricity. *Biofuel Cells: Materials and Challenges*. 2021 Jun 30:123-44.
- [44] Zang GL, Sheng GP, Li WW, Tong ZH, Zeng RJ, Shi C, Yu HQ. Nutrient removal and energy production in a urine treatment process using magnesium ammonium phosphate precipitation and a microbial fuel cell technique. *Physical Chemistry Chemical Physics*. 2012;14(6):1978-84.
- [45] Zhang G, Zhao Q, Jiao Y, Wang K, Lee DJ, Ren N. Efficient electricity generation from sewage sludge usingbiocathode microbial fuel cell. *Water research*. 2012 Jan 1;46(1):43-52.
- [46] Zhi Y, Liu H, Yao L. The effect of suspended sludge on electricity generation in microbial fuel cells. In2008 2nd International Conference on Bioinformatics and Biomedical Engineering 2008 May 16 (pp. 2923-2927). IEEE.
- [47] Zhou S. Working Principle and Application of Microbial Fuel Cell. *Innovation in Science and Technology*. 2022 Oct 11;1(3):51-5.