

# A REVIEW OF DEVELOPED MODELS OF POWER SUPPLIES FOR CARDIAC BIOSENSORS

## Abstract

Cardiac biosensors, which provide non-invasive, continuous, and real-time physiological data, have become essential instruments for monitoring and diagnosing a variety of heart-related disorders. The design and execution of effective and dependable power supply systems is one of the main obstacles encountered in the development of cardiac biosensors. This review study seeks to offer a thorough examination of the many developed power supply models made especially for cardiac biosensors. The evaluation includes a full analysis of the most advanced power supply models available today, covering both conventional battery-based methods and cutting-edge alternatives. It explores the benefits and drawbacks of each model and emphasises the impact of various power sources on the general effectiveness of cardiac biosensors.

**Keywords:** Biosensors, models, Microsystems, devices.

## Authors

### **Bharat Bhushan Sharma**

Department of Electronics & Communication Engineering

JSS Academy of Technical Education

Noida, Gautam Buddha Nagar, Uttar Pradesh India

### **Deependra Sharma**

Department of Electronics & Communication Engineering

JSS Academy of Technical Education

Noida, Gautam Buddha Nagar, Uttar Pradesh India

### **Rahul Kumar Gupta**

Department of Electronics & Communication Engineering

JSS Academy of Technical Education

Noida, Gautam Buddha Nagar, Uttar Pradesh India

### **Manoj Mathur**

BSNL

Broad-Band Section,

Hisar, Haryana, India

### **Raj Kumar Sharma**

AITSAP

Greater Noida, Uttar Pradesh, India

## I. INTRODUCTION

Due to silicon-based electronics' low power requirements, a wide range of battery-operated handheld, wearable, and even implanted medical devices are now possible. All of these gadgets require an energy source that is lightweight, portable, affordable, and compact to enable the desired portability and energy autonomy. The advantages of microsystem technologies over other technologies have led to their use in implantable biosensors. The power consumption of implanted medical devices has decreased as a result of recent advancements in microelectronics. Microsystems for implantable applications generally have low costs, tiny sizes, low weights, excellent dependability, low power, and greater functionality to offer. The primary energy source for wireless portable medical devices today is batteries. Despite the fact that batteries' energy density has increased by a factor of 3 over the past 15 years, their presence frequently has a significant impact on, if not complete control over, size and operational costs. Due to this, extensive research is being done on battery alternatives all around the world. One option is to swap them out for energy storage devices with higher energy densities, like miniature fuel cells. A second option is to supply the gadget with the energy it needs wirelessly; this approach, which is already used for RFID tags, can be expanded to include more power-hungry devices but calls for specialised transmission infrastructures. We see that interior light is roughly equivalent to thermal and vibration energy, whereas outdoor light performs better than all other energy sources. Additionally, we see that whereas energy seems to be abundant in industrial settings, it is considerably scarcer within the human body. By offering patients with a range of medical disorders ongoing monitoring and care, implantable medical devices have revolutionised healthcare. To maintain long-term performance, these devices, including pacemakers, neurostimulators, and implanted pumps, need a dependable power source. Radioactive power sources have become a realistic and effective alternative among the different power sources accessible for several implantable medical devices.

Large numbers of cheap, compact sensor nodes work together to gather data and send it to a base station over a wireless network to form wireless sensor networks. Applications in body area networks and health are expanding. IMDs, or implantable medical devices, are vital to the survival of people suffering from major illnesses like bradycardia, fibrillation, diabetes, and other disabilities, among others [1]. An active implantable medical device's (IMD) proper operation strongly depends on a steady supply of electricity. In this regard, it is crucial in clinics to provide long-term powering and recharging of an IMD in a very safe, effective, and practical manner. IMDs are powered by a variety of standard batteries, including lithium, nuclear, and biofuel cells, among others. Defibrillators and pacemakers that are external and implantable can help patients' hearts beat normally again. External and implantable defibrillators are the most often utilised medical equipment for people who have experienced sudden cardiac arrest. Due to its capacity to condense complex electronic circuitry to a very small size, improve reliability and longevity, and raise the sophistication of their programming and other automatic features, hybrid circuit technology is now the most widely used for implantable cardiac pacemakers.

The paper starts out by outlining the importance of cardiac biosensors in contemporary healthcare and highlighting the demand for optimised power supply solutions to improve their functionality and usefulness. The limitations and specifications particular to cardiac biosensors—such as biocompatibility, energy efficiency, and miniaturization—are

next explored. Additionally, this study examines cutting-edge power harvesting methods as possible alternatives to conventional battery-based power sources, such as energy harvesting from the kinetic or thermal energy of the human body. These novel methods offer chances to increase biosensor longevity and lessen the requirement for frequent replacements.

The evaluation also covers the significance of effective power management systems and their function in maximising power usage and extending the operational lifetime of the biosensor. In-depth research is conducted on a number of power management techniques, including duty cycling, adaptive power allocation, and low-power sensor designs.

Additionally, issues with wireless energy transfer and power transmission for implantable cardiac biosensors are addressed. Inductive coupling and radiofrequency-based power transfer techniques have recently advanced, and the paper explores these developments in detail to shed light on prospective innovations in this field.

**1. Secondary Batteries:** The primary batteries used in implantable medical devices are not acceptable due to their short lifespan of 8–10 years and potential for numerous surgical procedures for battery replacement. For the patients, this causes difficulties and is expensive. The proper and long-lasting operation of implantable medical equipment is thus made possible by auxiliary batteries. However, primary and secondary batteries can be used instead of secondary rechargeable batteries for external portable medical devices like AEDs. Nickel-cadmium rechargeable batteries were employed in the first clinical application of an implantable cardiac pacemaker (1960). Due to their mediocre performance, these pacemakers were abandoned. Rechargeable nickel-cadmium batteries did not significantly outlast main batteries in terms of service life. Lithium silver vanadium oxide batteries are used in commercially available implantable defibrillators; the typical arrangement is two batteries connected in series to create a six volt battery. Different external and implantable medical devices use a variety of rechargeable batteries, including lithium ion, mercury, nuclear, and biological power sources.

Presenting the function of lithium batteries in contemporary medicine by Curtis F. Holmes [2]. Since the first lithium-driven pacemaker was implanted in 1972, biomedical devices powered by lithium batteries have significantly contributed to lifesaving and health-improving treatments. Rechargeable lithium ion batteries for more recent implantable devices contribute to the availability of even more medicines for patients in need.

K A. Cook et.al [3], have created a MATLAB-based hybrid energy system design technique that makes it easier to choose power sources for a variety of wireless devices. By using an algorithm instead of choosing batteries by trial and error, power supply' mass and volume were significantly reduced. The various types of power sources for operating implantable medical devices are described by OrhanSoykan[4]. The reliability of the implantable device's battery has received the author's uttermost consideration because it is the only component with an uncertain and predictable service life, which in turn affects how long the implantable device will function.

## 2. Different Types of Power Sources

- **Inductive Powering for Implantable Biosensors:** An integrated full wave CMOS rectifier with improved efficiency has been developed by Song Guo et al. [5] for the transcutaneous power transfer in high current biomedical implants. Comparator-controlled switches were created to achieve unidirectional current flow while minimising voltage loss along the conducting channel. The unbalanced biasing technique additionally maximises the efficiency of the rectifier by reducing the reverse leakage current of the rectifier under various input amplitudes. The design of the low voltage comparator also makes it possible for the rectifier to self-start and handle low input amplitudes. The rectifier can source a 20 milliamperere maximum output current and has at least an 82% power efficiency, which can increase the effectiveness of the transcutaneous power transmission in high current implants. For the purpose of creating transcutaneous inductive powering for an implanted Microsystems device, SaadMutashar Abbas et al. [6] provide a PSPICE simulation. The design of the external component that will use the ASK modulation technique to send data and power to the implanted devices has been revealed. Power to the implanted devices may be efficiently transferred by the system [7].
- **Solar Energy Harvesting:** In order to facilitate utilisation on simulation platforms, Huan-Liang Tsai et al. [8] report the creation of a generalised photovoltaic model using the Matlab/Simulink software package. The suggested approach features a dialogue box and user-friendly icon similar to Simulink block libraries. Because of this, a maximum power point tracker can readily simulate and analyse the generalised PV model in conjunction with power electronics. The suggested model is used to simulate and optimise the output current and power characteristics of the PV model while taking the impact of solar radiation and cell temperature into account. This makes it simple to simulate, examine, and optimise the dynamics of a PV power system. Energy-saving and power-management strategies have been examined by S Y Kan et al. [9] in order to increase the energy consumption effectiveness of items powered by photovoltaics. Energy supply optimisation, which is necessary to deliver the actual energy to fulfil their function, is important in the design of such items, but so is effective energy transfer throughout the energy chain. It has been suggested that there are a number of ways to increase the energy chain's effectiveness. The utilisation of the product, its functional system, and optimisation techniques for photovoltaic powered items are all examined. Casey, Don E., [10], A device for powering implantable medical equipment is a subcutaneously implantable power supply. The device has a casing made of a lamination of several thin plastic layers containing one or more thin solar cells. Each layer is translucent in the region surrounding the corresponding cell, allowing the power supply to be sufficiently flexible to follow the contours of the body. The device features better scalability, improved internal battery longevity, and is lightweight and flexible. There have been extensive investigations on DC-DC converters to improve and stabilise the voltage produced by PV arrays with regard to changing temperatures and irradiance. Murakawa et al.'s use of infrared light of various intensities on solar cells placed beneath the chicken tissue allowed them to create a wireless near-infrared energy system for medical implants. They stated that 2mW/mm<sup>2</sup> is the maximum exposure permitted for human skin to near-infrared radiation.

- **Bio-fuel Cells Methods:** According to Xiaojuan WEI et al. [11], biofuel cells can be implanted in people to power IMDs or biosensors because they are biocompatible with the human body. At the moment, the main focus is on biofuel cells based on enzymes, which use an enzyme taken from the human body as a catalyst. A typical enzyme-based biofuel cell is used in applications like the self-powered glucose sensing used by diabetics or the long-term objective of the implantable power source for a cardiac pacemaker. The blood's glucose and oxygen serve as the fuel. In order to power a cardiac pacemaker, Sven Kerzenmacher et al. [12] created an effective, low power DC-DC converter for integrated glucose fuel cell. The sole power source used by the author to effectively demonstrate the continuous operation of a 15 microwatt pacemaker was an energy-harvesting, abiotically catalysed glucose fuel. This was made possible via an improved DC-DC converter, which outperforms commercially available circuits with a conversion efficiency of 40%. The authors have discussed the viability of using glucose fuel cells that have been abiotically catalysed as a long-term power source for various kinds of medical implants.
- **Piezoelectric Power Generator:** The operation of many drug pumps using piezoelectric materials as drivers to transform electric signal into mechanical action is presented by Xiaojuan WEI et al. in their study [11]. Typically, these pumps are employed in drug delivery systems, particularly for the treatment of diabetes. In the meanwhile, several tiny generators transform mechanical energy into electricity using piezoelectric materials. Therefore, the piezoelectric effect is a suitable option for supplying power to implantable cardiac pacemakers. A new class of self-powered implantable medical devices, sensors, and portable electronics may be made practical by piezoelectric generators, which transform mechanical energy from body movement, muscle stretching, or water flow into electricity.

Alim Dewan [13], Wherever there is a source of vibration, motion, or flow of any type, piezoelectric energy harvesters are used. Piezoelectric materials are subjected to pressure using mechanical energy from vibration, motion, or flow in order to produce electrical energy. The source of vibration, motion, or flow at faraway locations may be mechanical vibrations, mechanical or animal motion, water or wind flow, or ocean waves. Piezoelectric energy harvesters are put to engines, automobiles, wristwatches, implants, shoes, and other mobile and industrial equipment. The vibration-driven piezo electric micro generators for powering various wireless electronics devices have been described by Paul D. Mitcheson et al. [14]. Additionally, they evaluate the fundamentals and current state of motion-driven tiny energy harvesters, discuss trends, and suggest appropriate applications.

- **Thermoelectric Power Generator:** The suitability of thermoelectric power generator for implantable medical electronic devices has been discussed by Yang Yang et al. [15]. The idea of implanting a thermoelectric generator in a living organism to provide long-term electronic power for an implantable medical device has been investigated. The temperature differential within a biological body is converted into electrical energy by the thermoelectric generator. They have made an effort to assess a thermoelectric generator's ability to produce energy under various physiological or ambient thermal circumstances.

- **Electromagnetic Energy Harvesting:** A micro-generator, a high-ratio gear, and a metal magnet were implanted inside a person's body along with two-phase exciting coils in Suzuki et al.'s [16] design of an electric power producing system for IMDs. The revolving magnetic field is applied to the metal magnet inserted by the exciting coils, which causes the microgenerator to rotate. The micro-generator can create a lot of voltage since its spinning speed is significantly higher than that of the metal magnet thanks to the high-ratio gear. It has been discovered that a current of 0.48 A is induced and an output power of 11 mW is attainable when the external stimulating frequency reaches 16.7 Hz. Later, Suzuki et al. [17] put up a different idea on how to run IMDs. A magnetic coupling was employed by the electric power-generating system to send energy to the medical electronics that were deeply implanted. Through the rectifier and the charger, the generator's output is fed into the battery's charged system. This method yields an output power of 1.9 W (4.9 V, 390 mA). The rechargeable battery also requires 10 hours to fully charge. The two electromagnetic power supply systems are easy to produce and use as instruments. They function as a micro-motor, and the method for making the motor is now well developed. Such a technology costs less than nuclear cells because it does not require expensive materials. According to Jacopo Olivo et al. [18], electromagnetic transducer-based kinetic harvesters may be able to produce an electromotive force as a result of a change in an external magnetic flux passing via a closed circuit. For example, rotating the circuit around an axis can change the surface where the magnetic flux is located and so produce a change in flux. The system can be utilised to power the biosensors that are implanted.

### 3. Alternative Methods

- **Radio Frequency Power:** The review on radio frequency-based recharging approach for implantable medical devices was presented by Xiaojuan WEI et al. [11]. In reality, IMDs frequently use this method to send data and power to the inner circuit. Fig. 1 depicts the basic configuration for the RF method utilised in IMDs. The output power is connected to the transmitter coil, which is installed close to the skin, after being introduced to the power amplifier. A magnetic field created by the transmitter coil's alternating current can transmit energy through the skin. Near the transmitter coil in the human body is a reception coil. Induction in the receiver coil creates an electric voltage from the penetrating magnetic field. The mutual electromagnetic coupling between the transmitter coil and the receiver coil determines how effectively electromagnetic energy is transferred from the transmitter coil to the receiving coil.

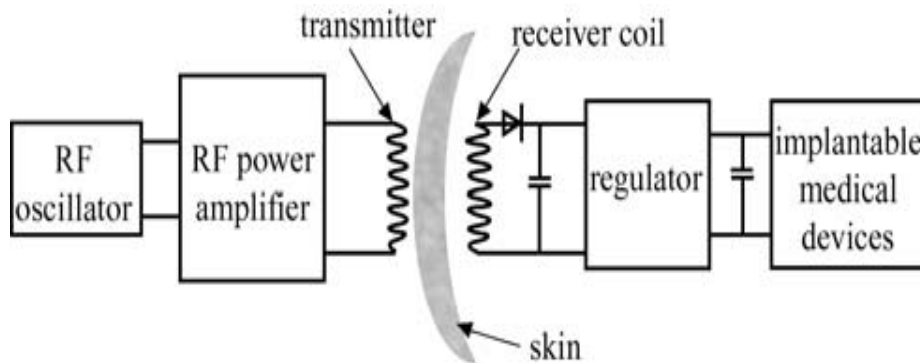

**Figure 1:** Schematic for an RF approach utilised in an implantable medical device

An antenna is subjected to an alternating voltage or current to produce an electromagnetic wave known as RF. The movement of the free electrons in the antenna's metal produces a magnetic field when voltage or current is applied. RF waves radiate from the antenna with a frequency equal to the supplied voltage due to the motion of electrons and the creation of a magnetic field. RF has a wavelength that ranges from 1 cm to 100 m and propagates at the speed of light. RF also uses photons, tiny energy units, to transport energy. Mo Jhang et al., [19] Due to its capacity to capture and transmit signals in vivo, microelectrode arrays have become an essential component of implantable biosensor applications. Monolithic integration is a trait that the implantable biosensors should have to save space and power. In 0.35  $\mu\text{m}$  CMOS technology, a low-power read-out circuit has been developed that uses just 400 W of power and takes up 0.66  $\text{mm}^2$  of space. The 400 W signal processing circuit, however, is not appropriate for implantable cardiac biosensors, which need 50 to 100 W to operate. The complete transmitter block may be simply powered by an external RF source and runs with a supply voltage as low as 1.5 V. The "smart" power management system described in this paper uses a microcontroller and features maximum power point tracking (MPPT) and online power stage efficiency optimisation. A new, more precise four-quadrant rectenna model and circuit realisation are used to experimentally evaluate the system, allowing for thorough testing of the power management system for a variety of rectenna arrays and power characteristics. Online optimisation is used to give hardware findings for a converter input power range of 10 W to 1 mW. Results from the application of harvesting RF power from a nearby cell tower are also displayed. In this case, the power management system gathers up to seven times more energy than a straight battery connection would.

A frequency-adjustable wireless energy system is presented by Fei Zhang et al. [20] to power implanted devices and medical sensors. A new wireless energy resonator has been created to transmit and receive energy. An RF power source, two resonators with novel structures, an inductively coupled input and output stage, and a prototype platform are all detailed. To confirm the viability of this platform, in vitro tests are conducted outdoors and with a human head phantom made of artificial tissues.

- **Radioactive Sources:** Radioisotopes, which release radiation as they undergo radioactive decay, are often the basis for radioactive power sources for implantable

medical devices. These isotopes were chosen because they fit the device's design and safety specifications and had the right half-life and decay properties. Promethium-147 (Pm-147) is the radioisotope that is most frequently utilised in implantable medical devices. Pm-147 emits beta radiation, which a solid-state semiconductor or thermocouple can use to generate electrical energy. Radium-226 (Ra-226), a radioisotope that emits alpha, beta, and gamma radiation, is another radioisotope that is sporadically employed. Its extended half-life and increased radiation energy levels, however, limit its use. There are some pacemakers on the market right now that use radioisotope thermoelectric generators. The metallic plutonium 238 (Pu-238) used in the Medtronic device is a small 2.5Ci slug. A thermopile converts the heat created by the Pu-238's radiation bombarding the container's walls into electrical energy. For IMDs, nuclear batteries have been shown to be trustworthy and safe. Metal alloys, carbon, and ceramic are the principal materials utilised to keep nuclear material hermetic. Some inert metal alloys, including platinum, tantalum, and gold or gold alloy, are qualified to be used as suitable shield materials for the application in powering IMDs.

To protect patients, radioactive power sources for implantable medical devices must adhere to stringent safety standards. Any major radiation exposure to the patient or nearby tissues must be avoided due to the power source's construction and containment. To contain the radioisotope and reduce the chance of radiation leakage, manufacturers use various layers of shielding, encapsulation, and fail-safe devices. Health authorities in different nations closely monitor and control the use of radioactive power sources in implantable medical devices. Before being approved for clinical use, the devices must pass stringent testing to show their safety, effectiveness, and compliance with established criteria. For some implantable medical devices, radioactive power sources have the potential to offer a dependable and long-lasting energy solution. They are a desirable option for enhancing the durability and dependability of these life-saving technologies due to their small size, prolonged lifespan, and steady energy production. However, its application necessitates meticulous examination and adherence to established rules to assure patient welfare due to the safety concerns and regulatory challenges involved.

## II. CONCLUSION

In conclusion, this analysis combines the various power supply methods for cardiac biosensors and assesses their usefulness, efficacy, and feasibility in practical settings. This study seeks to stimulate additional research and innovation in the field of cardiac biosensing technology by providing a thorough review of developed power supply models, ultimately improving patient care and expanding the field of personalised medicine. A thorough review of the literature was conducted on various powering techniques for portable medical equipment such as cardiac pacemakers and defibrillators. The majority of portable electronics run on batteries. For cardiac biosensors to operate sustainably, the issue of battery depletion over time forces one to consider battery recharge. Several writers have suggested recharging methods for implantable devices, including inductive powering, electromagnetic powering, radio frequency approaches, solar powering, etc. Additionally, to the best of our knowledge based on the literature that is currently available, no recharging method has been proposed for battery-operated automated external defibrillators for remote and inaccessible locations



lacking charging facilities. Additionally, some papers have discussed implantable solar power supplies for cardiac biosensors without maximising the power from a PV array and without using a boost converter to increase the voltage to a level suitable for charging the battery.

The energy scavenging technique is a desirable way to power medical implants in a sustainable manner. Implantable microelectronic medical devices, such as implantable cardiac biosensors, can be powered by solar energy. Implantable cardiac biosensors are one example of a medical device whose performance is dependent on a sustainable power source for continuous operation. An examination of the literature reveals that there has been substantial research on employing boost converters to capture energy from solar cells. However, there are few investigations on stabilising the voltage produced by solar cells as well as implanted solar cells for powering (recharging) implantable cardiac pacemakers (subcutaneous power supply). Therefore, the creation of an implanted device that can recharge batteries without endangering human skin is urgently needed. In remote places, it is also necessary to investigate solar power for recharging AED batteries. In photovoltaic (PV) systems, maximum power point tracking (MPPT) is used to maximise the output power of the photovoltaic array, regardless of the load's electrical characteristics, temperature, and irradiance.

## REFERENCES

- [1] R. S. Khandpur, "Handbook of biomedical instrumentation", 2<sup>nd</sup> Edition, Tata McGraw Hill Education Private Limited, New Delhi, 2003.
- [2] Curtis F. Holmes, "The role of lithium batteries in modern health care", *Journal of Power Sources*, vol. 97-98, pp. 739-741, 2001.
- [3] K. A. Cook, F. Albano, P.E. Nevius, and A. M. Sastry, "POWER (power optimization for wireless energy requirements): a matlab based algorithm for design of hybrid systems", *Journal of Power Sources*, vol. 159, pp. 758-780, 2006.
- [4] Orhan Soykan, "Power Sources for implantable medical devices", *Device Technology & Application Electronics*, pp. 76-79, 2002.
- [5] Song Guo, and Hoi Lee, "An efficiency-enhanced CMOS rectifier with unbalanced-biased comparators for transcutaneous-powered high-current implants", *IEEE Journal of Solid-State Circuits*, vol. 44, no. 6, pp. 1796-1804, June 2009.
- [6] Saad Mutashar Abbas, M.A. Hannan, S.A. Samad, and A. Hussain, "Designing transcutaneous inductive powering links for implanted microsystem device", *World Academy of Science, Engineering and Technology*, vol. 72, pp. 329-334, 2012.
- [7] Daniel Diaz, David Meneses, Jesus Angel Oliver, Oscar Garcia, Pedro Alou, and Jose Antonio Cobos, "Dynamic analysis of a boost converter with ripple cancellation network by model reduction techniques", *IEEE Transactions on power electronics*, vol. 24, no. 12, pp. 2769-2775, Dec. 2009.
- [8] Huan L. Tsai, Ci-Siang Tu, & Yi-Jie Su, "Development of generalized photovoltaic model using MATLAB/SIMULINK", *Proc., World Congress on Engineering and Computer Science*, San Francisco, USA, pp. 846-851, 2008.
- [9] S. Y. Kan, R. Strijk, "Towards a more efficient energy use in photovoltaic powered products", *Journal of Power Sources*, vol. 162, pp. 954-958, 2006.
- [10] Don E. Casey, "Subcutaneous implantable power supply", United States Patent, Pub. No. US 2003/0004546 A1, Jan. 2, 2003.
- [11] Xiaojuan WEI, & Jing Liu, "Power sources and electrical recharging strategies for implantable medical devices", *Front. Energy Power Eng. China*, vol. 2, no. 1, 2008, 1-13.
- [12] Sven Kerzenmacher, Steffen Zehnle, Tobias Volk, Dirk Jansen, Felix von Stetten, Roland Zengerle, "An efficient low-power dc-dc converter enables operation of a cardiac pacemaker by an integrated glucose fuel cell", *Proceedings of Power MEMS 2008+ microEMS2008*, Sendai, Japan, November 9-12, 2008.
- [13] A. Dewan, Suat U. Ay, M. Nazmul Karim, Haluk Beyenal, "Alternative power sources for remote sensors: a review", *Journal of power Sources*, vol. 245, pp. 129-143, 2014.

- [14] Paul D. Mitcheson, "Energy harvesting from human wearable and implantable bio-sensors", 32nd Annual International Conference of the IEEE EMBS, Argentina, pp. 3432-3436, 2010.
- [15] Yang Yang, Xiao-Juan Wei, and Jing Liu, "Suitability of a thermoelectric power generator for implantable medical electronic devices", *Journal of Physics D: Applied Physics*, vol. 40, pp. 5790-5800, 2007.
- [16] S. Suzuki, T. Katane, H. Saotome and O. Saito, "Electric power generating system using magnetic coupling for deeply implanted medical electronics devices", *IEEE Trans. Magnetic*, vol. 38, pp. 3006-3008, 2002.
- [17] Shin-nosuke Suzuki, Tamotsu Katane, Hideo Saotome, and Osami Saito, "Electric power-generating system using magnetic coupling for deeply implanted medicalelectronic devices," *IEEE Transactions on magnetics*, vol. 38, no. 5, pp. 306-3008, September 2002.
- [18] Jacopo Olivo, Sandro Carrara, and Giovanni De Micheli, "Biofuel cells and inductive powering as energy harvesting techniques for implantable sensors", *Science of Advanced Materials*, vol. 3, 420–425, 2011.
- [19] Mo Jhang, Mohammad R. Haider, Mohammad A. Huque, Mohammad A Adeeb, Shaela Rahman, and Syed K Islam, "A low power sensor signal processing circuit for implantable biosensor applications", *Smart Materials and Structures*, vol. 16, pp. 525-530, 2007.
- [20] Fei Zhang, Steven A. Hackworth, Xiaoyu Liu, Haiyan Chen, Robert J. Sclabassi, and Mingui Sun, "Wireless energy transfer platform for medical sensors and implantable devices", 31st Annual International Conference of the IEEE EMBS Minneapolis, Minnesota, USA, pp.1045-1048, September 2-6, 2009.