

# **SOLAR POWERED PREVENTION TECHNIQUES ENTRY OF MONKEYS INSIDE RESIDENTIAL AREA**

Prof. Sureshraj Se Pa  
Assistant Professor, Dept. of Electrical and  
Electronics Engineering  
J. J. College of Engineering and Technology  
Tiruchirappalli, India  
sureshraj@jjcet.ac.in

Mr. V. Naveen  
Final Year Student, Dept. of Electrical and  
Electronics Engineering  
J. J. College of Engineering and Technology  
Tiruchirappalli, India  
veeraiyannaveen27@gmail.com

Ms. P. Vanmathi  
Final Year Student, Dept. of Electrical and  
Electronics Engineering  
J. J. College of Engineering and Technology  
Tiruchirappalli, India  
vanmathi7702@gmail.com

Mr. Thilip Kumar  
Final Year Student, Dept. of Electrical and  
Electronics Engineering  
J. J. College of Engineering and Technology  
Tiruchirappalli, India

Mr. K. Prakash  
Final Year Student, Dept. of Electrical and  
Electronics Engineering  
J. J. College of Engineering and Technology  
Tiruchirappalli, India

## **ABSTRACT**

This Project is Proposed to prevent the entry of Monkey inside Residential area. The aim of this project is to prevent the monkey from entering into campus especially in classroom, staffroom and also in water filter. He This Project is Proposed to prevent the entry of Monkey inside Residential area. The aim of this project is to prevent the monkey from entering into campus especially in classroom, staffroom and also in water filter. Here, for Implementation we use solar as the power source and Infrared Radiation (IR) Sensor to restrict the entry of the Monkey. The proposed system consists of three main components: a solar power generation system, an intelligent monitoring system, and a deterrent mechanism. The solar power generation system harnesses sunlight to generate electricity, ensuring a self-sufficient and eco-friendly energy supply for the prevention system. The intelligent monitoring system employs advanced sensors, cameras, and computer vision algorithms to detect monkey activity and identify potential entry points. Real-time data processing and analysis enable timely responses to intrusion attempts. For Implementation we use solar as the power source and Infrared Radiation (IR) Sensor to restrict the entry of the Monkey. The proposed system consists of three main components: a solar power generation system, an intelligent monitoring system, and a deterrent mechanism. The solar power generation system harnesses sunlight to generate electricity, ensuring a self-sufficient and eco-friendly energy supply for the prevention system. The intelligent monitoring system employs advanced sensors, cameras, and computer vision algorithms to detect monkey activity and identify potential entry points. Real-time data processing and analysis enable timely responses to intrusion attempts.

## **I. INTRODUCTION**

The issue of monkeys entering residential areas and causing damage to property and harm to humans has become a growing concern in many parts of the world. This problem is particularly prevalent in areas where urbanization has encroached on the natural habitats of these primates. In order to mitigate this problem, there is a need for innovative solutions that not only prevent monkeys from entering residential areas but also promote the conservation of their natural habitat. One solution that has shown promise is the use of solar-powered devices to deter monkeys from entering residential areas. These devices can emit sounds and/or lights that are unpleasant to the primates, thereby preventing them from entering the area. In addition, by utilizing solar power, these devices

are ecofriendly and do not contribute to the carbon footprint of the area. Monkeys entering residential areas can cause significant damage and pose risks to both property and human safety.

To address this issue, solar-powered prevention techniques utilizing IR sensors and Arduino boards offer an effective and eco-friendly solution. This report outlines the implementation of such a system, its components, and its functionality .as resulted in their migration from the forest areas towards towns and cities and also to the cultivated areas. There is no centralised data bank on monkey raids in the country. According to the official and media reports, 20 States/UTs have reported significant crop damages due to monkey attacks. In 2018, about 250 villages in Jammu reported loss of farm produce worth Rs. 33 crores because of invasion by wild monkeys. Sometimes in severe attack, they cause damage up to 90% in agriculture and horticulture. They raid crops and utilize the agro-ecosystems for food resource and shelter. Hence monkeys are considered pests in the areas of massive agriculture, horticulture and other 3 plantations since they damage the crops and orchard. Monkeys are intelligent creatures that are known to cause trouble in residential areas, especially in regions where human settlements encroach upon their natural habitats. The entry of monkeys into residential areas can result in property damage, health risks, and conflicts between humans and wildlife. Therefore, it becomes essential to develop effective prevention techniques to mitigate the issue. This project aims to address this challenge by utilizing solar-powered technology, Arduino boards, and IR sensors to create a system that deters monkeys from entering residential premises.

#### **A. PROBLEM ARAISED**

The primary problem addressed by this project is the illegal entry of monkeys into residential areas and the resulting negative consequences. Traditional methods, such as fences or barriers, have proven to be ineffective in deterring monkeys due to their agility and adaptability. Hence, there is a need for an innovative and sustainable solution that leverages advanced technology.

#### **B. SIGNIFIANCE OF THE PROBLEM**

The significance of this project lies in its ability to provide an eco-friendly and humane solution to prevent the entry of monkeys into residential areas. By utilizing solar power, the system reduces reliance on conventional energy sources and promotes sustainable living. The implementation of Arduino boards and IR sensors enables real-time monitoring and response, enhancing the effectiveness of the prevention system.

#### **C. ARDUINO AND IR SENSOR**

The Arduino board, a popular open-source electronics platform, provides a versatile and user-friendly interface for controlling various electronic components. This page will discuss the integration of Arduino boards with IR sensors to detect the presence of monkeys. The IR sensor detects infrared radiation emitted by the monkeys' bodies, enabling the system to trigger appropriate responses in real-time.

#### **D. IR SENSOR CONFIGURATION AND CALIBRATION**

To detect the presence of monkeys, the IR sensors need to be appropriately configured and calibrated. This page will explain the calibration process, including setting the sensitivity levels, threshold values, and range of detection. It will also discuss potential challenges and considerations when deploying IR sensors in outdoor environments.

#### **E. REAL TIME MONITORING AND MECHANISM**

Upon detecting the pres the solar crop production system aims to utilize solar energy to power various components of the system, including sensors, actuators, and data collection devices. Solar panels can be installed in strategic locations within the farm to capture sunlight and convert it into electrical energy. This energy can be stored in batteries for continuous operation, ensuring the system remains functional even during periods of low sunlight. Using PIC microcontrollers, you can implement control systems that monitor and regulate environmental parameters such as temperature, humidity, and soil moisture. Animal sensors, such as RFID tags or GPS trackers, can be integrated with the PIC system to collect data on animal behaviour, movement, and grazing patterns. This data can then be processed and analyzed to gain insights into optimal crop rotation, grazing management, and environmental conditions of monkeys, the system triggers an alert mechanism to notify homeowners or relevant authorities. This section will delve into the details of the real-time monitoring aspect, including data collection, processing, and communication protocols. It will also explore different alert mechanisms, such as SMS notifications, alarms, or automated deterrent system.

## II. LITERATURE REVIEW

The solar crop production system aims to utilize solar energy to power various components of the system, including sensors, actuators, and data collection devices. Solar panels can be installed in strategic locations within the farm to capture sunlight and convert it into electrical energy. This energy can be stored in batteries for continuous operation, ensuring the system remains functional even during periods of low sunlight. Using PIC microcontrollers, you can implement control systems that monitor and regulate environmental parameters such as temperature, humidity, and soil moisture. Animal sensors, such as RFID tags or GPS trackers, can be integrated with the PIC system to collect data on animal behaviour, movement, and grazing patterns. This data can then be processed and analyzed to gain insights into optimal crop rotation, grazing management, and environmental conditions.

The PIC-based control system can automate irrigation and fertilization processes by utilizing the collected data from the sensors. It can precisely control the amount of water and nutrients supplied to the crops based on real-time requirements, thus minimizing waste and increasing efficiency. Additionally, the system can incorporate image recognition techniques to identify pests, diseases, or weeds in the crop fields, triggering targeted actions for pest and disease management.

A crucial aspect of the solar crop production system is the implementation of a user-friendly interface that provides real-time information and recommendations to farmers. The interface can display data analysis results, notify farmers of critical events, and offer suggestions for optimizing crop production. By providing farmers with actionable insights, the system enables informed decision making and efficient resource allocation.

The integration of solar energy into the crop production system reduces reliance on fossil fuels and promotes sustainability. By utilizing renewable energy sources, the system minimizes its carbon footprint and contributes to environmental conservation. To implement your solar crop production system using the PIC method, refer to relevant literature on PIC microcontrollers, solar energy integration, precision agriculture, and animal-based farming systems. Explore research papers, technical resources, and application notes to gain a deeper understanding of the specific implementation details and potential challenges associated with such a system.[1]

The detection of animal encroachment in crop fields is an important area of research, as it directly affects agricultural productivity and sustainability. In recent years, deep learning techniques combined with Internet of Things (IoT) technology have emerged as powerful tools for addressing this issue. This review aims to summarize the literature on the application of deep learning and IoT in the detection of animal encroachment in crop fields for a mini project. Numerous studies have utilized deep learning algorithms, such as convolutional neural networks (CNNs), for the detection and classification of animals in images or videos captured by IoT devices deployed in crop fields. These IoT devices, including cameras, sensors, and drones, provide real-time data that can be processed using deep learning models. The integration of IoT with deep learning enables continuous monitoring of crop fields and timely detection of animal intrusion, reducing crop damage and minimizing the need for manual inspections.

One prominent approach in this field involves training CNN models on large datasets containing images or videos of animals commonly found in crop fields. These models learn to recognize specific animal species or groups, distinguishing them from other objects or background elements. Transfer learning techniques have also been employed, where pre-trained CNN models are fine-tuned using smaller datasets specific to the target crop field and animal species.

To improve the accuracy and efficiency of detection, researchers have explored different strategies. For instance, some studies have employed data augmentation techniques to artificially expand the training datasets, allowing the models to generalize better. Others have employed object tracking algorithms to follow animal movements over time, providing additional context and reducing false positives. Additionally, the integration of IoT devices with other technologies, such as thermal imaging and acoustic sensors, has been investigated. Thermal cameras can detect the heat signatures of animals, while acoustic sensors can capture and analyze the sounds produced by them. These multimodal approaches further enhance the accuracy of animal detection and help differentiate between animals and environmental factors [2]

Overall, the combination of deep learning and IoT technology offers promising prospects for the detection of animal encroachment in crop fields. It enables real-time monitoring, early detection, and prompt intervention, which are crucial for minimizing crop damage and ensuring sustainable agricultural practices. Nevertheless, further research is still needed to optimize the performance of deep learning models, explore new IoT sensor configurations, and investigate the feasibility of implementing these systems on a larger scale.

The Internet of Things (IoT) has revolutionized the way we interact with our environment, including the agricultural sector. In recent years, farmers have increasingly adopted IoT solutions to improve crop production and reduce losses caused by various environmental factors. One of the major challenges faced by farmers is the damage caused by wild animals, which can result in significant financial losses. This project aims to develop an IoT-based solution to protect crops against wild animal attacks. The proposed system will consist of a network of sensors and devices that will monitor the farm and alert farmers in case of any intrusion by wild animals. The system will use machine learning algorithms to analyse the data collected by the sensors and provide real-time alerts to the farmers.

The IoT solution will incorporate various components, including sensors for monitoring temperature, humidity, soil moisture, and animal movement, as well as cameras and other surveillance equipment. The collected data will be sent to a central server for analysis, where machine learning algorithms will be used to identify patterns and anomalies that may indicate the presence of wild animals.

The solution will be designed to be cost-effective and easy to use, with a user-friendly interface that allows farmers to monitor their crops remotely. By implementing this system, farmers can significantly reduce the damage caused by wild animals and improve their crop yields, resulting in a more sustainable and profitable farming business.[3]

Agriculture is the primary source of livelihood for millions of people around the world. However, crop damage by animals is a significant challenge that farmers face, resulting in significant economic losses. In recent years, the use of solar fencing has emerged as an effective way to protect crops from animal damage.

The concept of solar fencing involves electrifying a fence using a solar-powered electric fence energizer that delivers a non-lethal but unpleasant shock to animals that touch the fence. This shock trains animals to stay away from the crop area, thereby preventing crop damage. The benefits of solar fencing for crop protection include its effectiveness as a deterrent, low cost, environmental friendliness, and ease of installation and maintenance. This project aims to install solar fencing in agricultural areas to prevent crop damage by animals and assess its effectiveness in reducing crop losses.[4]. The agriculture industry is facing various challenges, including the protection of crops and livestock from wild animals. Wild animals such as coyotes, foxes, wolves, and birds can cause significant damage to crops, leading to financial losses for farmers. As a result, there is a need for an effective animal detection system that can detect the presence of these animals in farm areas and alert the farmers. To develop an animal detection system that can detect and identify wild animals in farm areas using various technologies such as sensors, cameras, and other surveillance equipment. The system will be designed to be cost-effective, easy to install, and operate, and provide real-time alerts to farmers in case of any intrusion by wild animals.

The animal detection system will be based on the integration of multiple sensors and cameras that can capture images, videos, and detect animal movements. The system will use machine learning algorithms to analyse the collected data and identify patterns that indicate the presence of wild animals. The machine learning algorithms will be trained on a large dataset of animal images to improve the accuracy of the detection system [5].

The animal detection system will also be integrated with a central server that will store the collected data and provide real time alerts to farmers in case of any intrusion by wild animals. The alerts can be sent via email, SMS, or a mobile app, allowing farmers to take immediate action to protect their crops and livestock. To reduce the man and animal conflicts several methods are introduced by different persons. The common aim of these methods is to reduce the problems caused by the animals to the human and keep them in a safe distance. In the PIR sensor and ultrasonic sensors detect the different animals and there is a mechanism to send an alert signal to the farmers and forest department by the GSM module. This system can detect human and animals separately. In [6], Surendar and Pachamama have proposed a method of protecting the rooftop gardens from pests without use of any pesticides. Two mechanisms are there one for day and one for night. The ultrasonic sound generator is used to repel the pests during daytime and LED lights which attracts the insects are used during night time.

The animals can be also repelled by an idea of camera trapping, it is based on the principle of image processing and bioacoustics. This system can detect the animals differently and produce sounds of a particular frequencies which is audible only to the animal species which is detected. It is proposed in [7]. Vijaya Raghavan Sundararajan, Vijayalakshmi T G and Swathi Venkatadri have done an analysis on using ultrasonic sound generator to repel dogs using solar power in [8]. It reduces the road accidents caused by the dogs and animals with same hearing range of dogs.

The mechanism to reduce power system transient faults caused by birds by avoiding the presence of birds near the transmission lines is discussed in [9]. Ultrasonic sound generators are used to repel the birds and solar power is used as the power source. In [10], the insects are driven away using the ultrasonic sounds of different frequencies. The different types of insects are repelled by two modes, one with DTMF and another with LDR.

Yahot Siahaan, Bheta Agus Wardijiono and Yulisdin Mukhlis have proposed a method to repel birds with the help of an android system in [11]. PIR sensor is used to detect the birds and piezo ultrasonic sensor is used as repeller. An android system is connected to the Arduino Uno which shares information when birds are detected. In [12] a mechanism to repel mosquitos using ultrasonic sound waves is proposed instead of using chemicals to kill mosquitos. The piezoelectric effect is utilized to produce ultrasonic sounds.

The method to prevent the monkeys from agricultural fields using ultrasonic sounds with application of flooding algorithm is discussed in [13]. The ultrasonic sensor is used to detect and repel the monkeys, ultrasonic sound with a particular frequency with is only audible to monkey is generated when monkeys are detected. In [14], the birds are driven away from the agricultural fields by producing scatter sounds. Solar power is the power source and different scatter sounds are produced for different species of birds [15,16].

### **III. PROPOSED METHOD**

The proposed system consists of three main components: a solar power generation system, an intelligent monitoring system, and a deterrent mechanism. The solar power generation system harnesses sunlight to generate electricity, ensuring a self-sufficient and eco-friendly energy supply for the prevention system. The intelligent monitoring system employs advanced sensors, cameras, and computer vision algorithms to detect monkey activity and identify potential entry points. Real-time data processing and analysis enable timely responses to intrusion attempts.

The deterrent mechanism, integrated with the solar-powered system, employs a combination of non-harmful deterrent methods. These include ultrasonic devices, motion-activated water sprinklers, and sound-emitting devices strategically placed around the residential area. Upon detecting a monkey's presence, the system activates the deterrent measures, creating a hostile environment that discourages further entry attempts.

The solar-powered prevention system offers several advantages over conventional approaches. First, it eliminates the reliance on grid electricity, reducing operational costs and minimizing the environmental impact. Second, the intelligent monitoring system enhances accuracy and responsiveness, minimizing false alarms and optimizing energy usage. Third, the combination of multiple deterrent methods maximizes effectiveness, ensuring a comprehensive defence against monkey intrusion. Furthermore, the proposed system can be customized and scaled according to the specific needs of different residential areas, allowing for adaptability and flexibility. Additionally, the integration of solar power aligns with the global shift towards sustainable and renewable energy sources, promoting eco-conscious practices in wildlife management.

In conclusion, these abstract highlights a solar-powered prevention system designed to combat the issue of illegal monkey entry into residential areas. By harnessing solar energy, employing intelligent monitoring, and utilizing a range of deterrent mechanisms, this solution offers an effective and sustainable approach to mitigate property damage, ensure safety, and restore ecological balance in affected regions.

## A. CIRCUIT DIAGRAM

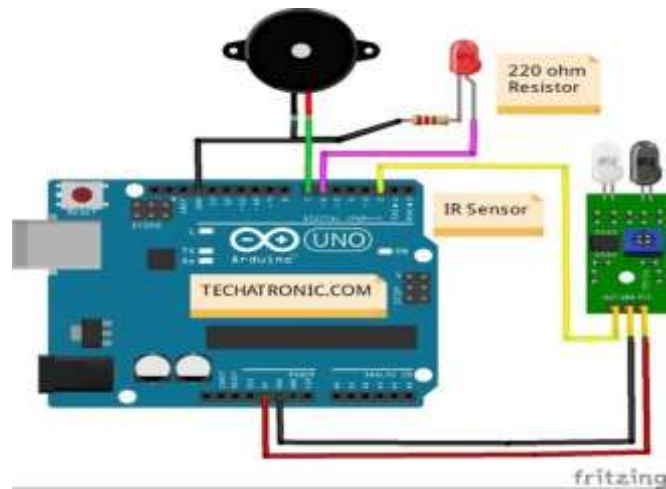

**Figure 1: Circuit diagram of proposed method.**

IR sensor contains two LEDs one is white which is an Infrared Light transmitter and another one is Black which is an Infrared Light receiver. As the name suggests their work is so obvious. The sensor is built out of LM358 IC and is similar to LM393 IC which I think you all must be familiar with and know a bit about this IC.

The difference between the two is very simple in digital output only high or low means either 1 or 0 is transmitted to a microcontroller but in the analog signal, a wide range of values from 0 to 1023 is transmitted to the microcontroller which relates to the intensity of light received by the receiver. You can also slightly trim the values of the IR sensor with Arduino with the help of a potentiometer provided on the sensor PCB.

when the IR Sensor with Arduino detects anything it will notify by the LED. the next image is for the Sound notification we will use the buzzer in that circuit. First, take the power lines onto the breadboard from the microcontroller VCC/5V->+ line and GND->- line. Then connect the sensor to the breadboard and connect power to the sensor from powerlines using jumper wires.

Now connect LED to the breadboard + to digital pin 13 of Arduino and - to and in series with 220-ohm resistor. Moreover, we can also use it in analog mode by that simply connecting the A0 pin of the sensor to pin A0 of the microcontroller. Enhance this version by adding a buzzer to it also like in the above diagram. Connect -live of the buzzer to GND on a breadboard, and +ive to 5V on a breadboard

## IV. CONCLUSION

Now a days the monkey menace is increasing and people are using various methods to avoid them, which will also cause harm to them. The ways followed by the people to avoid them are by making electric boundaries, hunting them down, making big noises which cause noise pollution, by making traps etc. These are not the suitable ways to avoid them. By using the proposed device, we can minimize the damage caused due to monkey menace, as well as, repel the monkeys without causing any harm to it. This is the effective method to drive away monkeys to a safe distance The problem of crop canalization by wild animals has become a major social problem in current time. It requires urgent attention as no effective solution exists till date for this problem. Thus, this project carries a great social relevance as it aims to address this problem. This project will help farmers in protecting their orchards and fields and save them from significant financial losses and will save them from the unproductive efforts that they endure for the protection their fields. This will also help them in achieving better crop yields thus leading to their economic wellbeing. Integrating features of all the hardware components used have been developed in it. Presence of every module has been reasoned out and placed carefully, thus contributing to the best working of the unit. Secondly, using highly advanced ICs with the help of growing technology, the project has been successfully implemented. Thus, the project has been successfully designed and tested.

## REFERENCE

- [1] Astif bherani, Gauravkumar N. raut, pawan D. kale “smart design of microcontroller for agriculture,” international conference on circuit, power and computing technologies , IEEE 2014 monitoring system.
- [2] Bapat, Varsha, Prasad Kale, Vijaykumar Shinde, Neha Deshpande, and Arvind Shaligram. "WSN application for crop protection to divert animal intrusions in the agricultural land." *Computers and electronics in agriculture* 133 (2017): 88- 96.
- [3] Balakrishna, K., Fazil Mohammed, C. R. Ullas, C. M. Hema, and S. K. Sonakshi. "Application of IOT and machine learning in crop protection against animal intrusion." *Global Transitions Proceedings* 2, no. 2 (2021): 169-174.
- [4] “Design with PIC microcontrollers” by J B Peatman
- [5] “Embedded C Programming and the Microchip PIC” by Richard H Barnett.
- [6] Dr. Wilson, "ELECTRIC FENCE," Handbook of Texas, Project report published by the Texas State Historical Association. August 4, 2011
- [7] Radha, R., K. Kathiravan, V. Vineeth, J. Sanjay, and S. Venkatesh. "Prevention of monkey trespassing in agricultural field using application agricultural specific flooding approach in wireless sensor network." In *2015 IEEE Technological Innovation in ICT for Agriculture and Rural Development (TIAR)*, pp. 106-111. IEEE, 2015.
- [8] T. Day and R. Mac Gibbon, “Multiple-Species Exclusion Fencing and Technology for Mainland Sites.”, Project Report published by National Wildlife Research Centre, 2007.
- [9] R. Padula and W. Head, “Fencing System ”Project Report published by University of Minnesota, 2003. 33
- [10] Rocabert, Joan, et al. "Intelligent connection agent for three-phase gridconnected microgrids." *IEEE Transactions on power electronics* 26.10 (2011): 2993-3005.
- [11] Guerrero, Josep M., et al. "Advanced control architectures for intelligent microgrids—Part II: Power quality, energy storage, and AC/DC microgrids." *IEEE Transactions on industrial electronics* 60.4 (2012): 1263- 1270.
- [12] Miret, Jaume, et al. "A flexible experimental laboratory for distributed generation networks based on power inverters." *Energies* 10.10 (2017): 1589.
- [13] Guerrero, Josep M., et al. "Advanced control architectures for intelligent microgrids—Part I: Decentralized and hierarchical control." *IEEE Transactions on Industrial Electronics* 60.4 (2012): 1254-1262.
- [14] De Andrade, Flávia, Miguel Castilla, and Benedito Donizeti Bonatto. *Basic Tutorial on Simulation of Microgrids Control Using MATLAB® & Simulink® Software*. Springer Nature, 2020.
- [15] Hespanha, Joao P. "Lecture notes on lqr/lqg controller design." *Knowledge creation diffusion utilization* (2005).
- [16] Se Pa, S.; Yakoob, M.B.; Maruthai, P.; Singaravelu, K.; Duraisamy, N.; Palaniappan, R.D.; Pithai, J.B. Machine Learning Gaussian Process Regression based Robust H-Infinity Controller Design for Solar PV System to Achieve High Performance and Guarantee Stability. *Eng. Proc.* **2022**, *19*, 26. <https://doi.org/10.3390/ECP2022-12631>