

## **Dimensional Model Development in a Business Intelligence Environment Using e-CRM**

### **The Process of Creating Technical Institution Data Warehousing**

The concept of data warehousing has evolved out of the need for easy access to a structured store of quality data that can be used for decision making. It is globally accepted that information is a very powerful asset that can provide significant benefits to any organization and a competitive advantage in the business world. Organizations/Institutions have vast amounts of data but have found it increasingly difficult to access it and make use of it. This is because it is in many different formats, exists on many different platforms, and resides in many different file and database structures developed by different vendors. Thus the institutions have had to write and maintain perhaps hundreds of programs that are used to extract, prepare and consolidate data for use by many different applications for analysis and reporting. Also, decision makers often want to dig deeper into the data once initial findings are made. This would typically require modification of the extract programs or development of new ones. The above process is very costly, inefficient and very time consuming. That is the background to have a very efficient data warehousing approach for the technical institutions.

Data warehousing implements the process to access heterogeneous data sources; clean, filter and transform the data; and store the data in a structure that is easy to access, understand and use. The data is then used for query, reporting and data analysis.

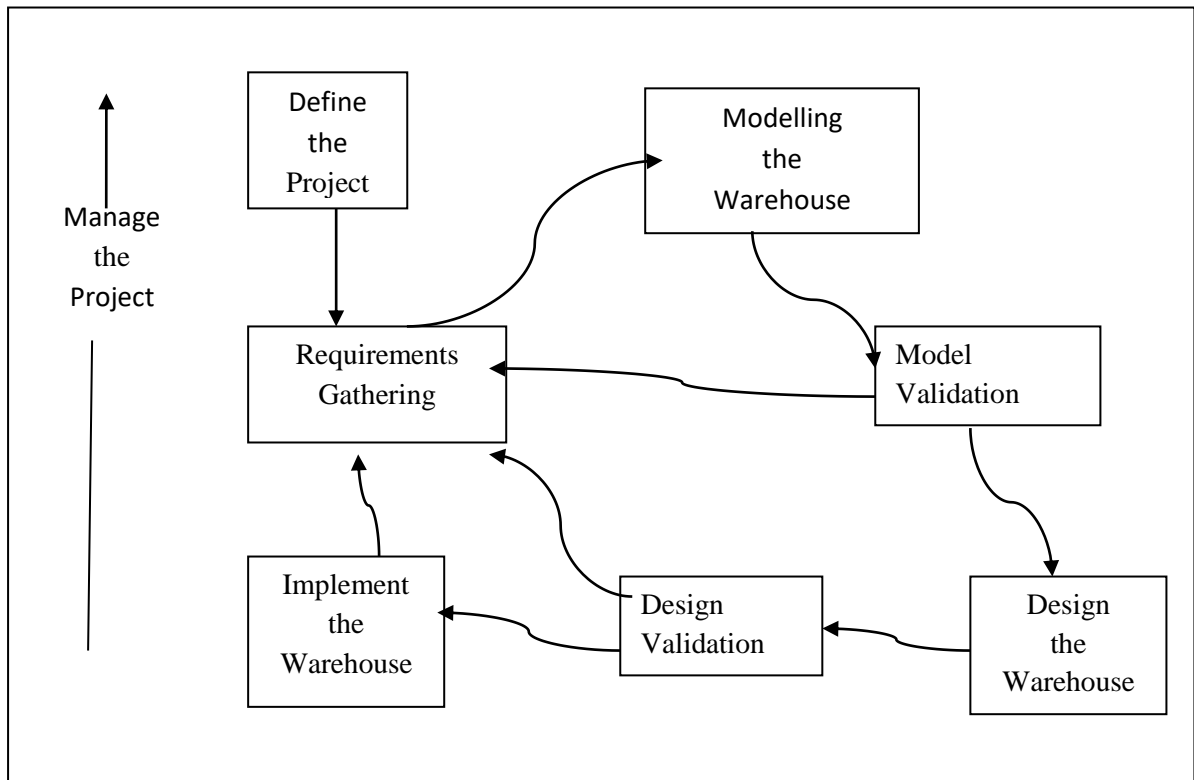

**Fig. 1: Data Warehouse Development Cycle**

The process of developing a data warehouse is similar in many respects to any other development project. Fig1 shows the typical data warehouse development cycle. It is certainly true that there is no one correct or definitive life cycle for developing a data warehouse. Because the above development cycle focuses really on modelling, the specific life cycle is not an issue here. The above diagram seems to infer a single instance of a data warehouse. Clearly, this should be considered a logical view. That is, there could be multiple physical instances of a data warehouse involved in the environment. For the dimensional modelling the integration might take place at the dimension level itself. The fig. 1 is the iterative nature of data warehouse development. In the current research study the above iterative method is used to develop the technical institution data warehouse.

To overcome the problems of having adhoc reporting with ER modelling and to get the faster response time when accessing the reports we have decided to have dimensional databases (also called data marts) that would allow reporting and data

analysis tasks in the way the customer/business demands. This model is developed under Business Intelligence using e-CRM.

Dimensional modelling (DM) is the name of a set of techniques and concepts used in data warehouse design. It is considered to be different from entity-relationship modelling (ER). Dimensional Modelling does not necessarily involve a relational database. The same modelling approach, at the logical level, can be used for any physical form, such as multidimensional database or even flat files. According to data warehousing consultant Ralph Kimball, Dimensional Modelling is a design technique for databases intended to support end-user queries in a data warehouse. It is oriented around understandability and performance. According to him, although transaction-oriented ER is very useful for the transaction capture, it should be avoided for end-user delivery.

Dimensional modelling always uses the concepts of facts (measures), and dimensions (context). Facts are typically (but not always) numeric values that can be aggregated, and dimensions are groups of hierarchies and descriptors that define the facts. For example, sales amount is a fact; timestamp, course, register#, store#, etc. are elements of dimensions. Dimensional models are built by business process area, e.g. store sales, inventory, claims, etc. Because the different business process areas share some but not all dimensions, efficiency in design, operation, and consistency, is achieved using conformed dimensions, i.e. using one copy of the shared dimension across subject areas. The term "conformed dimensions" was originated by Ralph Kimball.

### **The All India Council for Technical Education (AICTE)**

The All India Council for Technical Education (AICTE), set-up in November 1945 as a national level Apex Advisory Body, marches ahead with its mission of developing and promoting quality technical education in the country in a coordinated and integrated manner. The Council is constantly endeavouring to encourage a meaningful association between the technical education system and research and development activities in a concerted effort aimed at nation-building.

Technical education at all levels in the country is witnessing a consistent growth pattern marked by the setting up of new Institutions and the improvement of the

existing ones in tune with the quality assurance norms set by the National Board of Accreditation (NBA). The Council believes in providing a proper impetus to Institutions in generating competent engineers and scientists and encourages them to think beyond the curriculum while imparting training for the advancement of knowledge.

### **Dimensional Modelling Design for Technical Institution using e-CRM**

The main considerations of a data modelling methodology revolve around the process as well as the process inputs.

#### **Process:**

The foundation of most data model theory is derived from the ANSI/SPARC three schema architecture proposed by Tsichritzis and Klug [1]. The architecture separates the conceptual, logical (external or application view), and physical (internal view) levels. The purpose of a conceptual data model is to explore high level domain concepts; the purpose of a logical data model is to define the entities, attributes and relationships for an enterprise project; and the purpose of a physical data model is to design the schema of a database [2]. Moving from the conceptual model to physical model entails an increase of structured information at each level. Thus a conceptual model is required before either a logical or physical model can be developed.

The two important groups of conceptual data modelling methodologies are the ER model and Object Role Modelling (ORD) [3].

Chen [4] proposed the ER model by presenting a technique that described entities and relationships in a graphical format, using a set of shapes and lines. Using a top-down approach, entities are first identified, followed by the relationships between the entities and the attributes of the entity. Despite the ER model giving birth to a number of variations, criticisms were levelled at the model's lack of clarity of definitions. Codd [5] said that "the major problem with the entity-relationship approach is that one person's entity is another person's relationship".

The three most popular variations on the ER model are the Information Engineering model [6], IDEFIX [7] and the Oracle Method [8]. The Information Engineering

Model was an attempt to refine the ER model by discarding the notion of a complex relationship, and terming the relationship itself as an entity. Thus every relationship is binary, as only two entities are involved (or one entity for a reflexive relationship). Coming from the family of ICAM Definition Languages, IDEFIX had widespread usage in the US because it is mandatory for government projects.

Advocates of Object Oriented Modelling argue that their methodologies capture a broader range of structural features and constraints compared to the ER-based models [8]. ORM does not distinguish graphically between an entity and an attribute on the premise that the relationship between an attribute and entity is conceptually the same as a relationship between two entities. This allows the representation of subtleties not available in ER modelling. ORM also has a rigorous means of dealing with higher arity relationships when the number of objects amongst a relation is greater than two.

The methodology in this chapter has its roots based in the ER model due to the simplicity and pervasiveness of the technique.

### **Modelling Inputs**

A comprehensive data model requires a comprehensive modelling process and a thorough knowledge of the domain. In order to develop the multi-dimensional model in the area of technical education management and for the data requirements, the different business processes are studied using e-CRM activities. These activities formed the inputs for the modelling process.

### **Data Model Patterns**

There are several definition attributed to the word of 'pattern' [9]. A pattern is a template from which something can be derived. A pattern is also reoccurring characteristics of multiple objects. Patterns literature within the computer science revolves around providing exemplars of good practice. As one of the aims of this work is to provide a reference model, the characteristics of patters are significant to note.

There are numerous branches of patterns literature ranging from object models, integration models, data models, to meta data models. While the area is broad, the

focus for this work is on data model patterns in which there are three seminal works. These are books by Hay [10], Fowler [11], and Silverston [12]. Both Hay and Fowler provide more conceptual models where the focus is on entities, their relationships and cardinalities. Silverston [12] concentrates on providing logical models that include attributes, and are one step removed from physical models.

There are several works in enterprise object model patterns [13, 14, 15] that are useful to conceptual data modelling. The qualifier 'enterprise' is used to differentiate from creational, structural and behavioural object patterns such as those by the Gang of Four [16]. Despite the impedance mismatch between object models and data models [17], a data model can be derived as object modelling forms a superset of relational modelling. As the aim is to provide a conceptual data model, the object model patterns need to be abstracted through technique such as class categorisation to discover the underlying theory upon which they are based.

In a similar vein to patterns, albeit from a commercial perspective, ADRM (Applied Data Resource Management) provide enterprise, business area, data warehouse and data mart models for various industries [18]. Starting from a common enterprise model, contextual elements are added for various organizations.

### **Business Process Models**

In order to understand, redesign, and optimise existing business processes, organizations/Institutions are undertaking business process modelling to capture their business processes. These models show the relationship between activities, data entities, resources and goals. The connection between activities forms a flow, and branches can be defined using Boolean logic to indicate where decisions are required. As the main goal of data warehousing is to provide a foundation for decision support, business process modelling has an impact on conceptual data modelling by dictating the types of data required to be supported in the model.

### **Modelling Conventions**

Hay [10] divides data modelling conventions into three areas: Syntactic, positional and semantic. Syntactic conventions are those that dictate the symbols that are used. Positional conventions involve the arrangement of symbols in relation to other

elements. Semantic conventions deal with the grouping of elements based upon their meaning. This section describes the modelling convention used throughout the conceptual data model.

### **Syntactic Conventions**

The symbolic notation used in the following sections is derived from a combination of UML and Crow's Foot notation. UML is the standardised specification language produced by the Object Management Group for object modelling. It uses graphical notation to create an abstract model of a system. Crow's Foot notation was proposed by Everest [19] in order to enhance the clarity of entity relationship notation.

### **Positional Conventions**

The simple method to arrange a model is through random placement of entities on a page. As this method can be confusing, such a practice has evolved placing entities, but with a minimal crossing of line. Further refinements have seen 90° bends removed, and horizontal/vertical alignment of shapes.

The CASE method technique orients entities such that the Crows' Foot on a relationship face to the left and top of the diagram [8]. This has the effect of placing entities representing tangible objects in the lower right area of the diagram, while entities representing less tangible roles, interactions, and transactions move to the upper left.

Fowler [11] prescribes another philosophy that splits a model into a knowledge level and an operational level. The knowledge level forms the rules and types that govern the activities of the operational level. The operational level instantiates the knowledge level and contains more frequently changing information. This is the convention adopted in the conceptual data model although exceptions are made for clarity.

### **Semantic Conventions**

Semantic conventions can be defined at two levels. The first deals with modelling similarities in business situations from different organisations. It is postulated by Hay [10] that despite the intrinsic differences between organisations, the models

constructed come from a common set of contentions of thought i.e. model patterns. Thus, identifying the basic elements of a specific business will lead to identification of businesses in general.

The second is the configuration of elements within the similar business situations. There are reoccurring structures that exist within models such as roles or activities undertaken by people or organizations, classifications of objects into types, and processing of monetary transactions. At these two levels, a vocabulary of common business situations and structures can be developed that form the semantic conventions when developing data models. This vocabulary is taken from patterns literature, as well as studies into various companies.

## **Issues in Conceptual Data Modelling**

### **Scope of Integrated Areas**

The conceptual data model aims to provide an understanding of how the different areas involved in technical institutions are integrated. It is very difficult to get the clear idea about how it is contributing in technical institutions data management. It is difficult to find out the different activities in technical institutions which will help to integrate the internal as well as external data.

### **Generality and Implementation**

As postulated and attempted by Hay [10] with his Universal Data Model, there exists a generic data model that is applicable to record every type of data in every type of circumstance. While the answer lies in judiciously using the common Entity Attribute Value (EAV) pattern, the answer is not HAY's University Data Model as it cannot represent relationship attributes, value types and characteristic durations. To be able to derive a useful implementation model, the conceptual data model needs to be more descriptive. However, there is no clear definition on the level of detail required, and hence design choices are made throughout the model.

### **External Data**

An important characteristic to data warehouses is their ability to integrate data from sources external to the organization. This includes currency rates, different types of



advertisement, service provided, different types of campaigns, prices etc. Some of these data are already integrated into information systems either manually or automatically. It could be argued that once data are transferred to an organization's information systems, they are no longer classified as external data. In either case, the distinction is not important as it is only a superficial categorisation and despite the conceptual data model including support for some external data, no explicit distinction is made.

### **Time**

The concept of time plays an integral role in data warehousing. Time is a fundamental dimension that is found in nearly every data warehousing schema, and forms the basic analysis unit for reports. Many approaches have been devised to provide support for the treatment of time in data models, but most interpret the temporal relation as a sequence of states indexed by points in time [20]. Some temporal models also include the transaction time of creation and modification of these time points to fully capture all temporal information. Most entities in the conceptual data model are designed with a temporal consideration, while the transaction times are handled by metadata.

### **Metadata**

Metadata commonly described as data about data, is an integral part of a physical data model. ISO 15489 and ISO 23081 discuss records management and metadata, and give guidelines on the management of both digital and non-digital data. Traditional metadata include statuses of records, dates of creation, modification and deletion as well as users who undertook these events. More advanced metadata can include access control records, retention periods, business context information and data quality indicators. Metadata plays a notable role within data warehousing and there are many resources on data warehouse metadata management [21] including modelling metadata [22] and mining metadata [23]. Metadata is not included in the conceptual data modelling as the model focuses on the content. However, the aforementioned metadata types can be used in conjunction with the model.

### **Primitive Data Types**

Object attributes of primitive data types (e.g: characters, integers, floating-point numbers, Boolean, strings and time) were identified for the purposes of developing the data model, but were not explicitly described. The only exception is with the time data type as (1) time is vital to data warehousing and consequently (2) there are some unique uses of time that are not typically found in current information systems and require explanation.

## **Technical Institution Conceptual Dimensional Data Model using e-CRM**

The dimensional model design life cycle (DMDL) which consists of the following phases:

- Identify business process requirements
- Identify the grain
- Identify the dimensions
- Identify the facts
- Verify the model
- Physical design considerations
- Meta data management

**Fig. Data Warehouse Architecture with Data Marts**

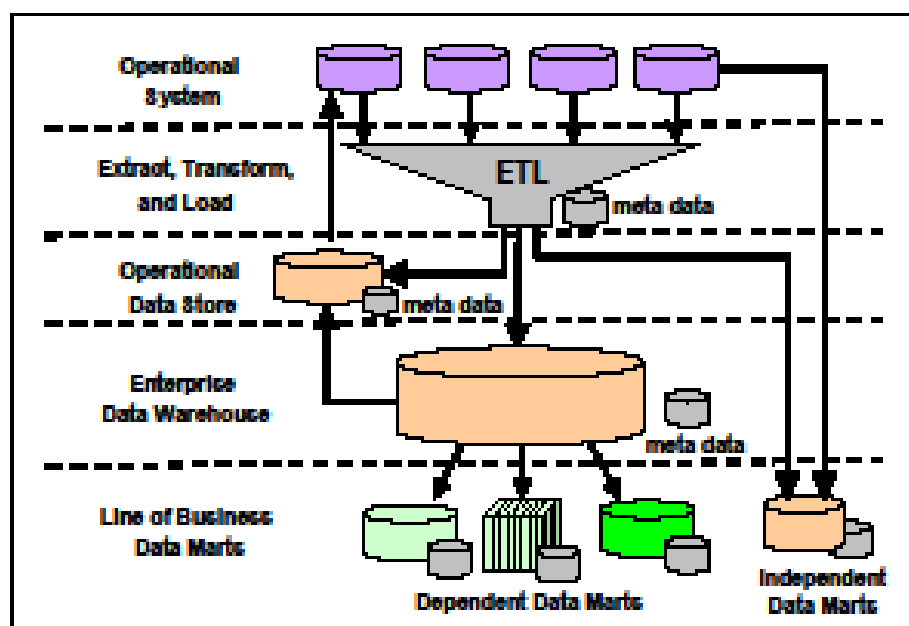

Data modelling is important because it specifies the data structure, which can impact all aspects of data usage. It can have significant impact on performance of the business. This is true in the case of data warehousing. The data warehouse is a primary structural element in business intelligence. Key to business intelligence is the ability to analyze huge volumes of data, typically by means of query processing and analytic applications. The primary aim of a data model is to make sure that all data objects required by the business are accurately and fully represented.

A dimensional model is also commonly called a star schema. This type of model is very popular in data warehousing because it can provide much better query performance, especially on very large queries than an E/R model. However, it also has the major benefit of being easier to understand. It consists, typically of large table of facts (known as a fact table), with a number of other tables surrounding it that contain descriptive data, called dimensions. To help the organization/business in decision process, the phases of developing a dimensional model is as follows:

- a) **Identity Business Process Requirements** – Involves selection of the business process for which the dimensional model will be designed. Based on the selection, the requirements for the business process are gathered. Selecting a single business process, out of all those that exist in an organization, often requires prioritizing the business processes according to criteria, such as business process significance, quality of data in the source systems, and the feasibility and complexity of the business processes.
- b) **Identify the Grain** – Identify the grain definition for the business process. If more than one grain definition exists for a single business process, then we must design separate fact tables. Avoid forcefully fitting the multiple grain definitions into the same fact table. We also need to make sure that we design the grain at the most atomic level of detail so that we can extend the dimensional model to meet future business requirements. In other words, we are able to add new facts and dimensions to the existing model with little or no

change to the front-end applications, or any major rework to the existing model.

- c) **Identify the Dimensions** – Identify the dimensions that are valid for the grain chosen in the previous step.
- d) **Identify the facts** – *Identify the facts that are valid for the grain definition we chose.*
- e) **Verify the Model** – We must verify the dimensional model can meet the business requirements. Sometimes it may be required to revisit, and perhaps change, the definition of the grain to assure we can meet the requirements.
- f) **Physical Design considerations** – The model so designed should be considered for the performance. It may require tuning by taking actions such as data placement, partitioning, indexing, partitioning and creating aggregates.
- g) **Meta data Management** – to work with changes to data, structure and requirements.

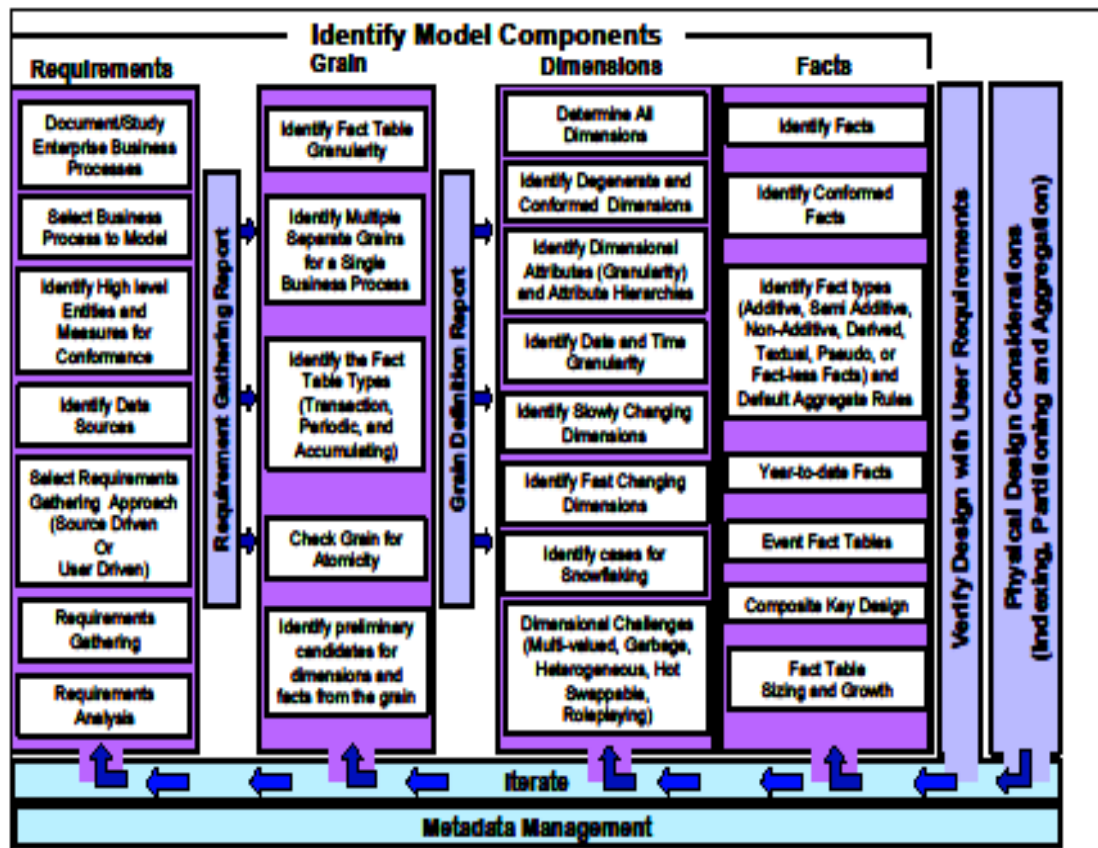

Fig. Dimensional Model Design Life cycle

Considering the above steps the dimensional model is developed using e-CRM activities in the technical institutions and for each activity one star schema was developed and checked for effective performance and similarly all the data marts are created for acquisition as well as retention activities and finally those dependent data marts are integrated.

### **Business Activities**

The AICTE was set up in November 1945 based on the recommendations of CAGE to stimulate, coordinate and control the provisions of educational facilities and industrial development of the post war period. At that time, mandate of AICTE basically covered only programs in Engineering and Technology.

The growth of industries in the Country, just after independence, also demanded the need for qualified professionals in other fields, such as Business Management, Architecture, Hotel Management, Pharmacy etc. Although the diverse elements of Management such as Commerce, Economics, Finance, Psychology and Industrial Sociology were being taught for a long time, the need for Management Education in a formal way was felt in India only in the fifties. The Government of India decided in 1954 to set up a Board of Management Studies under AICTE to formulate standards and promote Management Education. Other major initiatives taken in Management Education include: setting up of the Administrative Staff College of India at Hyderabad in the late fifties, National Productivity Council and Indian Institution of Management in the early sixties. Architecture was covered under the Architects Act, 1972. Subsequently, for better coordination of the Professional Courses, Architecture Education was also placed under the purview of AICTE.

Hotel Management Education had a modest beginning with short programs in Nutrition and Food Science, which started in the late fifties. The National Council of Hotel Management and Catering Technology were set up in 1982, to which all the Institutions of Hotel Management run by the Government are affiliated.

Education in other professional fields such as, Pharmacy, Applied Arts & Crafts has also undergone similar developments during the post-independence period. Programs

for Technical Education, during the first three Five Year Plans, were devoted to expansion of Technical Education to meet the growing demand for technical personnel at Diploma, Degree and Post-Graduate Levels. From the fourth Five Year Plan onwards, the emphasis was shifted to the improvement of quality and standard of Technical Education. This was done through implementation of the Quality Improvement Program consisting of three major components that provided for M.E. / M. Tech and Ph. D Programs, Establishment of Curriculum Design and Development Cells, and Short Term Training Programs.

Meanwhile, expansion of Institutions and intake remained at a low level in the Government, Private-aided and University sectors. The policy shift during eighties towards involvement of Private and Voluntary Organizations in the setting up of Technical and Management Institutions on self-financing basis ushered in an era of unprecedented expansion of the Technical Education System, a trend which has continued during successive Five Year Plans.

It was in this context that AICTE was given statutory powers by the AICTE Act of Parliament in 1987, with a view to ensure the proper planning and coordinated development of Technical Education System throughout the Country. Technical Education in this context includes fields of Engineering and Technology, Architecture, Town Planning, Management, Pharmacy and Applied Arts & Crafts.

For our research work we have studied one of the Technical Institution which was started in the year 2006 offering Technical Education.

In 2006 the institutions started and offering Bachelor of Engineering in Computer Science & Engineering, Information Science & Engineering, Electronics and Communication Engineering and Mechanical Engineering.

In 2007 Master of Business Administration was started along with other courses.

In 2008 Master of Computer Application was started along with above courses.

In 2010 it started the M.Tech. courses in Digital Electronics and Industrial Automation and Robotics.

In 2012 it started B.E. courses in Automobile Engineering, Marine Engineering and Bachelor of Architecture. It also started M.Tech. courses in Computer Networks, VLSI.

### **Course/Product Lines**

The technical institution offers several courses. This will help the technical institution to sustain in the competitive global market.

The courses offered by the technical institutions are divided into four categories:

1. Under-graduate Degree Programs (Full-time)
2. Post Graduate Degree and Post Graduate Diploma Programs (Full Time)
3. Diploma Programs (Full Time)
4. Post Diploma Programs (Full Time)

### **Under-graduate Degree Programs (full-time) comprises of the following courses**

- a) Engineering & Technology (4 years)
- b) Engineering & Technology (Lateral Entry to Second Year)
- c) Pharmacy (4 years)
- d) Architecture (5 years)
- e) HMCT (4 years)
- f) Applied Arts & Crafts (5 years)
- g) All programs other than Engineering (Lateral entry to second year)
- h) All programs other than Engineering (Entry to First year)

### **Post-Graduate Degree and Post-Graduate Diploma Programs comprises of the following courses**

- a) Management (PGDM, MBA and Similar (2 years)
- b) Management (PGCM) (More than 1 yr but less than 2 yrs)
- c) Management (Executive PGDM) (15 months)
- d) MCA (3 years)
- e) M.E./M.Tech. (2 years)
- f) M.Pharm. (2 years)
- g) M. Arch. (2 years)

- h) Hotel Management & Catering Technology (2 years)
- i) Applied Arts & Crafts (2 years)

**Diploma Programs comprises of the following courses**

- a) Engineering & Technology (3/4 years)
- b) Pharmacy (2 years after XII Standard or ¾ years after Xth standard where same exists)
- c) Architecture (3/4 years)
- d) Hotel Management & Catering Technology (3 years after XII Standard or ¾ years after Xth standard where same exists)
- e) Applied Arts & Crafts (3/4 years)
- f) All programs (Lateral entry to 2<sup>nd</sup> years Diploma)

**Post-Diploma Program comprises of following courses**

- a) Engineering & Technology (1.5 years /2 years)
- b) Pharmacy (1.5 years/2 years)
- c) Architecture (1.5 years / 2 years)
- d) Hotel Management & Catering Technology (1.5 years /2 years)
- e) Applied Arts & Crafts (1.5 years /2 years)

For our study we have identified the following product lines in the college selected.

**Under-graduate Degree Programs (full-time) comprises of the following courses**

- a) Engineering & Technology (4 years)
- b) Engineering & Technology (Lateral Entry to Second Year)
- c) Architecture (5 years)

**Post-Graduate Degree and Post-Graduate Diploma Programs comprises of the following courses**

- d) Management (PGDM, MBA and Similar (2 years)
- e) MCA (3 years)
- f) M.E./M.Tech. (2 years)



## **IT Architecture**

AICTE affiliated technical institutions are spread across the different states in the country. In some of the technical institutions they have their own ERP systems according to the business activities they have in their state with different legal requirements. Activities related to the customer are covered by the CRM or e-CRM systems. It used the Enterprise data model with dependent data marts with eCRM strategy.

## **Identify the Requirements**

### **Enterprise-wise Business Process List**

#### **Customer Acquisition**

- Advertising
- Customer Segmentation & Profiling
- Campaign Management
- Merchandizing
- Sales Analysis

#### **Customer Retention**

- Customer Service
- Fulfilment
- Course Quality
- Call Centre Support
- Trust & Privacy

## **Business Process Assessment**

**Table: Point Table for Assessment Factor**

Assessment Factor	Low	Medium	High
-------------------	-----	--------	------

Complexity	6	4	2
Data Quality & Availability	3	6	9
Strategic Business	2	4	6
System Availability	1	2	3

**Table: Business Process Assessment**

Name of the Business Process	Complexity	Data Quality & Availability	System Availability	Strategic Business Significance
Advertising	Medium	Medium	Medium	Low
Customer Segmentation & Profiling	Medium	High	High	Medium
Campaign Management	Medium	Medium	Medium	Low
Merchandizing	Medium	Medium	Medium	Low
Sales Analysis	Medium	High	High	High
Customer Service	High	Medium	Medium	Medium
Fulfillment	Low	Medium	Low	Low
Course Quality	Medium	Medium	Medium	Medium
Call Centre Support	Medium	High	High	Low
Trust & Privacy	Medium	Low	Medium	Medium

**Note:**

1. We have rated both the data quality and availability and the system availability factors as **High** for all the processes whose data is already present in the data warehouse system of record.
2. For all the outsourced processes, or process candidates for outsourcing, we have rated the strategic business significance as **low**.

- Marketing data and system availability has been rated as **medium** because the data partially comes from external sources.

### **Technical Institution Multi-Dimensional Modelling using e-CRM in a Business Intelligence Environment**

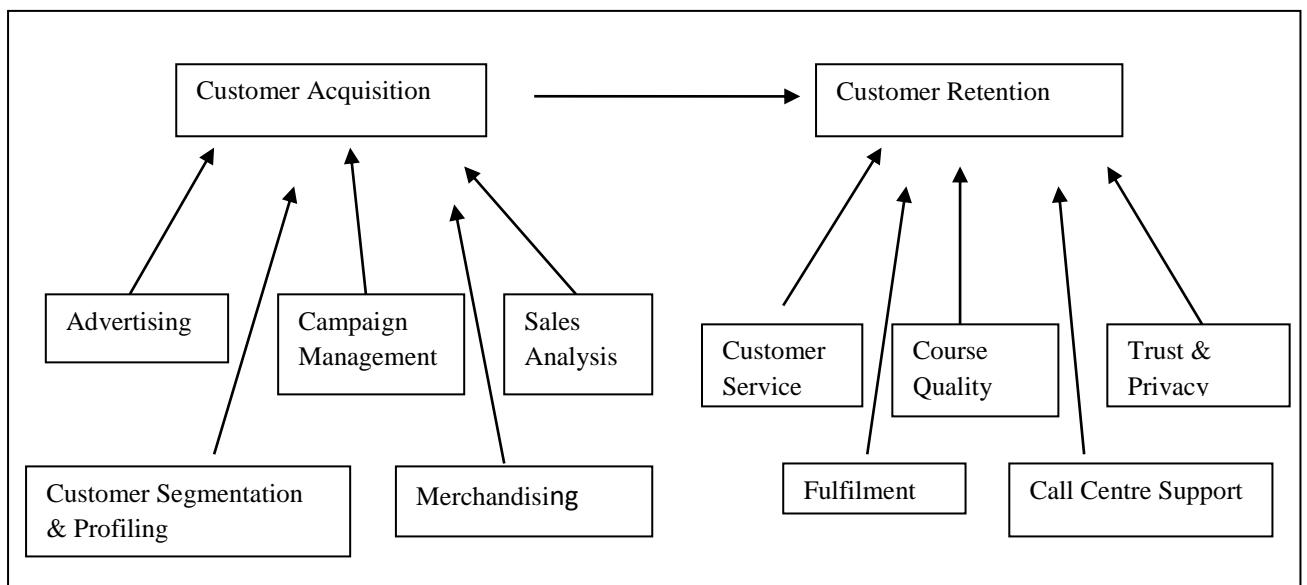

**Fig. Activities of e-CRM**

#### **Customer Acquisition**

Customer acquisition is necessary to establish and build market share. This is especially critical for the institutions entering into new markets where they hope to gain market dominance before the competition becomes well entrenched.

Acquisition strategies focus on getting new customers to enroll himself/herself into a course or service for the first time and that includes the following activities.

## **Advertising**

The effectiveness of today's online advertising comprises of the following aspects:

### **Information**

Advertisement supplies consumers with information about courses and services. This information is broadcast to the open market, and discusses specials, sales, and new lines of courses and services. A consumer also learns about the comparisons between features, benefits and options of different courses and services through advertisement.

### **Brand Identity**

Brand identity is one of the biggest functions and effects of advertisement. By selling courses and services through advertisements, businesses differentiate themselves from one another. The right advertising campaign defines a company's unique brand, which helps consumers build emotional relationships with that brand. This increases the likelihood that consumers will buy from that company.

### **Promoting Action**

Advertising's purpose is to attract buyers through a call-to-action statement, which encourages the customer to visit a store or website, or to contact the advertiser for more information. Advertising is essentially an action catalyst that brings customers and courses or services together.

### **Improving Customer Base**

A business requires a constant customer base in order to remain successful. The business needs to target its courses and services toward this customer base and consistently create new courses that attract current and new customers. Advertising helps reinforce the purchasing behaviours of customers for a particular brand, and it establishes long-term relationships with existing customers, potential customers, vendors and stockholders.

### **Course Creation**

Advertising, according to “The Social and Cultural Effects of Advertising” by Jeremiah O’Sullivan R., stimulates the development of better courses, and allows consumers to have a wider variety of courses, competitive pricing, and competition entering the marketplace.

### **Purchase Persuasion**

Powerful and captivating advertisements persuade consumers to purchase a new course, try out services, and fulfil voids they feel are present in their lives. In fact, persuasion is one of the main functions of advertising, which is why many firms strive to create powerful impacts that reach customers on emotional and physical levels.

### **Education**

Advertising serves as a form of consumer education. Not all advertisements sell a course or service; sometimes they sell a concept. Government agencies use advertisement as a way to educate and compel consumers to act in a specific way. “The Social and Cultural Effects of Advertising” notes that advertising is geared toward the ideas of art, religion, sexual attraction and myth. Advertising also educates consumers on what courses and services are out there, how much they should pay, and what they can expect with certain purchases.

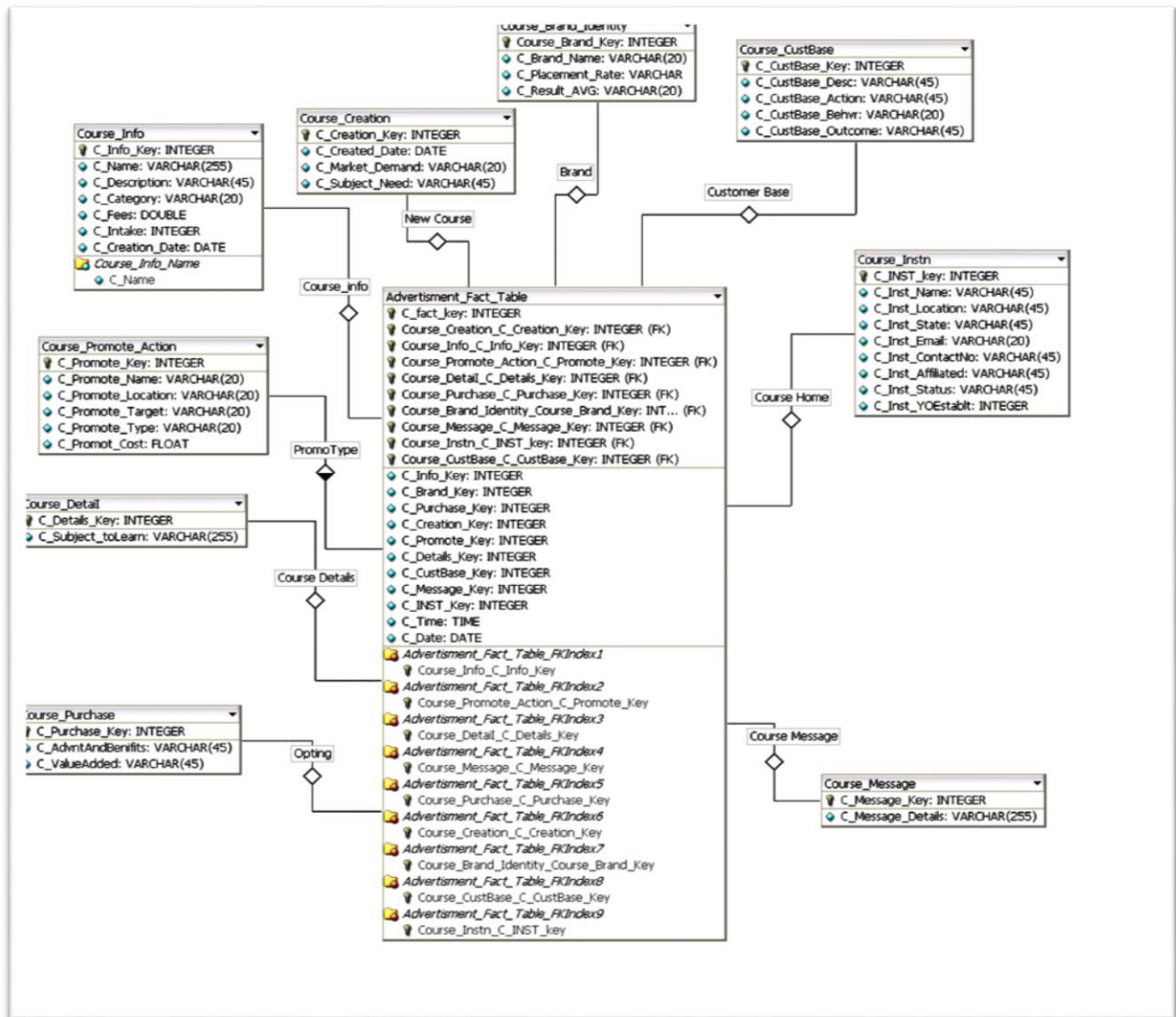

**Fig. : Data Mart for Advertisement**

### **Customer Segmentation and Profiling**

A customer profile is a way of describing a customer categorically so that they can be grouped for marketing and advertising purposes. It has been shown to be more profitable to target advertising to a specific market segment. As a short-hand way of talking about consumers, market segments are often represented by consumer profiles.

Customers/consumers can be identified by many different preference, lifestyle, life stage, attribute, and trait categories. Thinking about consumers in terms of the way they are represented by categorical tiers can be useful. The first tier includes the most common categories for describing consumers, such as demographics, socio-economic

status, and course usage. The second tier extends the concepts of the first tier and includes psychographics, generation, geography, geo-demographics, and benefits sought. Basic definitions of these concepts are provided below:

**Demographic:** Attributes related age, city or region of residence, gender, race and ethnicity, and composition of household.

**Socioeconomic:** Attributes related to household income, educational attainment, occupation, neighborhood, and association memberships.

**Brand affinity / Course usage :** This is associated with course engagement on the basis of their behavior.

**Psychographics:** This Attributes related to lifestyles, life stage, personality, attitudes, opinion, and even voting behavior.

**Generation:** Attributes related to a specific identifiable generation cohort group.

**Geography:** Attributes related to the geographical area in which consumers reside and work.

**Geo-demographics :** Attributes that combine geography and demographics which may cluster into identifiable group.

**Benefits Sought :** Attributes related to the benefits that consumers seek when they shop for courses and services.

The reliable segmentation and profiling are achievable with two conditions:

1. Data must be available from as many customer touch points as possible. This provides the depth of data required on each customer's activities.
2. There must be a large profiling database to allow comparisons of known customer activities against anonymous customers in the profiling database.

This database provides the breadth of data necessary for accurate comparative analysis.

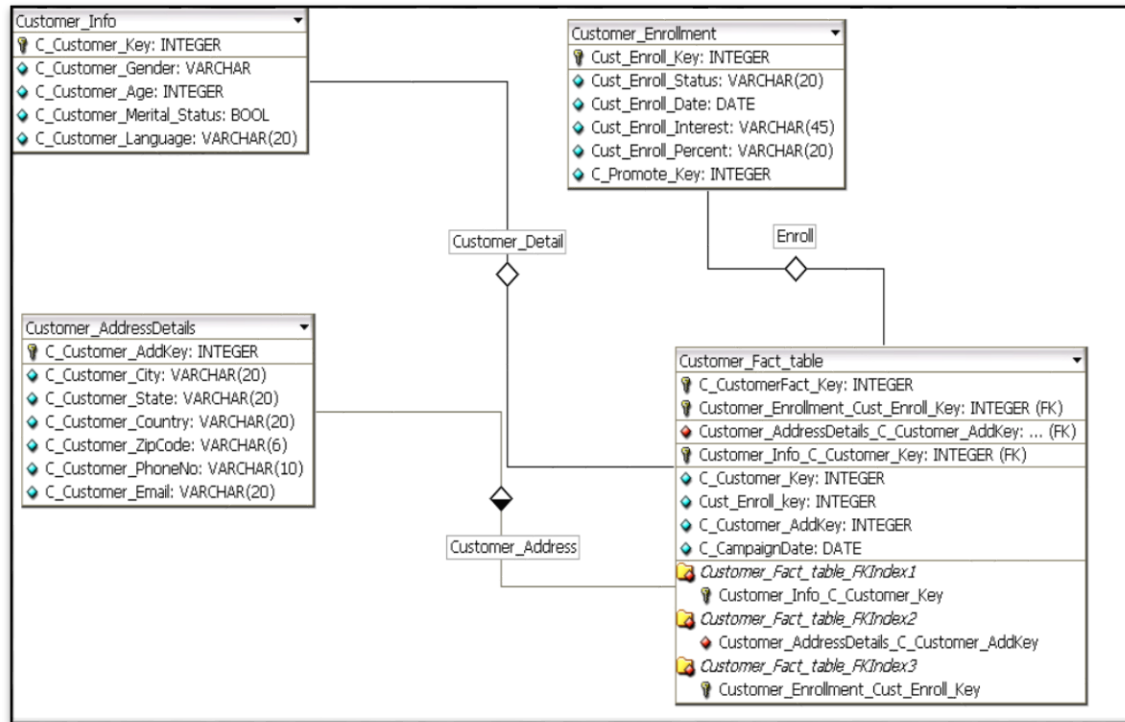

**Fig.: Data Mart for Customer Segmentation & Profiling**

### **Campaign Management**

Successful campaign management is about much more than simply scoring campaign effectiveness based on customer response rates. The web has introduced significant new variables into the commerce equation, and understanding which combination of course, pricing, target customer, channel and presentation will be most effective is pivotal to business success.

Pricing is certainly among the critical factors for profitability in today's markets. Marketers need to clearly understand which of your customer segments are most price-sensitive in order to offer pricing relative to their lifetime value to an organization. Balancing offers with customer profitability and predicted campaign effectiveness will ultimately determine which of your campaigns succeed and whether they are profitable.



Channel behaviour must be sufficiently understood in order to reach customers across their preferred channel. Because this preferred channel can vary for different courses and different customers and can even change over time, accurate customer segmentation and profiling are critical for successful management of sales campaign.

Every customer interaction generates data. Data which helps to understand a customer as an individual and reveal clues about how best to engage them. Clues which help to deliver relevant, timely and engaging marketing communications. Campaign effectiveness based on customer response rate.

The fields should consist of the departments, services, value additions, fee structure and all the information about the courses and institutions so that the customer should get all the information in one stretch so that he will be satisfied as well as attracted towards the institution.

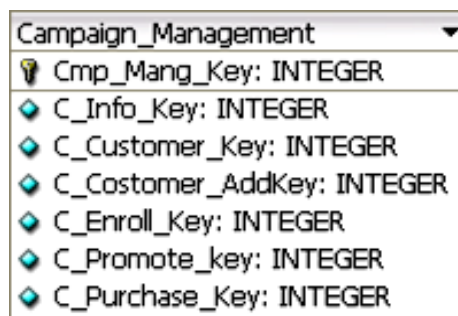

Campaign_Management	
🔑	Cmp_Mang_Key: INTEGER
🔑	C_Info_Key: INTEGER
🔑	C_Customer_Key: INTEGER
🔑	C_Costomer_AddKey: INTEGER
🔑	C_Enroll_Key: INTEGER
🔑	C_Promote_key: INTEGER
🔑	C_Purchase_Key: INTEGER

**Fig.: Data Mart for Campaign Management**

## **Merchandizing**

Online merchandizing defines how a web site organizes and delivers content to visitors in support of the organizations web strategy whether the goal is sales, course education or customer service.

Visual merchandising builds upon or augments the retail design of a store. It is one of the final stages in setting out a store in a way customers find attractive and appealing.

The elements used are College information, course information, fee structure, value-additions and special features, subjects.

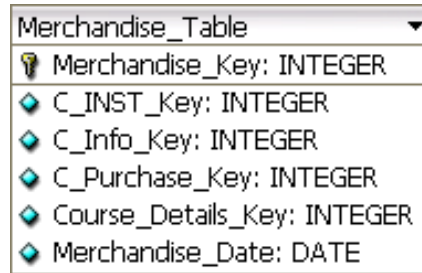

Merchandise_Table	
Merchandise_Key	INTEGER
C_INST_Key	INTEGER
C_Info_Key	INTEGER
C_Purchase_Key	INTEGER
Course_Details_Key	INTEGER
Merchandise_Date	DATE

**Fig.: Data Mart for Merchandizing**

### **Sales Analysis**

Multi-channel sales analysis should provide a composite picture of customer profitability. This allows the costs of marketing and loyalty programs to be measured against the predicted lifetime value of a customer. While it is important to grow customer value, we cannot lose sight of shareholder value. That is the cost of increasing customer value must be balanced with expected returns of that value, ensuring maximum return on the investment.

Here the importance should be given to how students are finding out the course information from different channels i.e. directly from the college or through the web site or through a call centre or through catalogues or telesales. Purchase behaviour must be seen in aggregate across all channels.

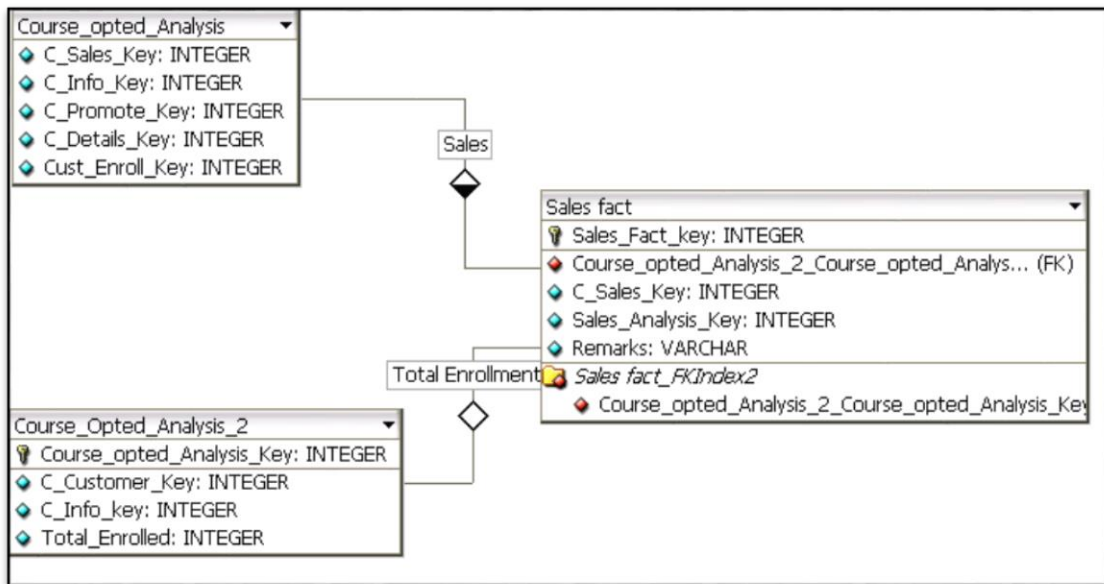

**Fig.: Data Mart for Sales Analysis**

The individual data mart for Advertisement, Customer Segmentation and Profiling, Campaign Management, Merchandizing and Sales Analysis is created using DB Designer4 and tuples are entered.

### **Customer Retention**

Customer acquisition is about getting new customers. Customer retention is about keeping the ones you already have. According to the Harvard Business Management Review, the cost of acquiring a new customer is six to eight times higher than retaining a current customer. Therefore, effective retention strategies are critical for the organizations with an established customer base that are looking to improve their bottom line. A successful customer retention strategy will have two goals: 1) Eliminating the negative in the customer’s experiences and 2) Enhancing the positives.

Both of these goals are important in building a lasting loyalty that will maximize customer lifetime value. Loyalty and retention include customer service, fulfilment, course quality, call centre support and trust and privacy.

## **Customer Service**





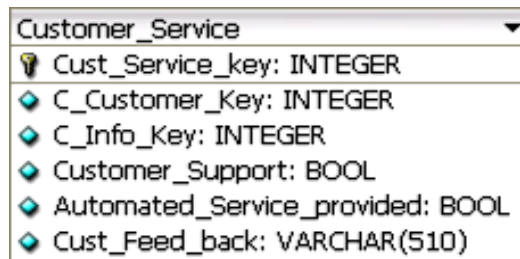

Customer service quality plays a significant role in customer satisfaction and loyalty. By eliminating the negatives in the customer experience, happy customers are given no reason to defect. By enhancing the positives, an organization creates a more attractive 'whole course' which is the core course wrapped in high quality customer service that builds loyalty and may even win sales from price hunting customers.

The fields are the

Customer service provided through

- a) Customer support
- b) Automated Customer Service
- c) Instant Feedback



Customer_Service	
	Cust_Service_key: INTEGER
	C_Customer_Key: INTEGER
	C_Info_Key: INTEGER
	Customer_Support: BOOL
	Automated_Service_provided: BOOL
	Cust_Feed_back: VARCHAR(510)

**Fig.: Data Mart for Customer Service**

## **Fulfilment**

It is the process of making a student to join the course as early as possible without any problems after he/she has accepted it. In an Educational Institution fulfilment is an easier process.

Online catalogue and telemarketing channels help the customer to get the maximum information regarding the courses. Fulfilment plays a vital role in customer satisfaction.

Good fulfilment quality requires careful analysis of Course information, available seats, course starting dates and information related to selected course.

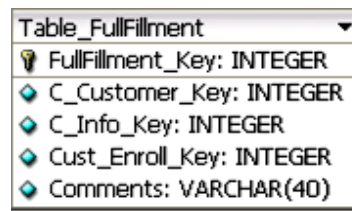

Table_Fullfillment	
Fullfillment_Key	INTEGER
C_Customer_Key	INTEGER
C_Info_Key	INTEGER
Cust_Enroll_Key	INTEGER
Comments	VARCHAR(40)

**Fig.: Data Mart for Fulfilment**

### **Course Quality**

Good customer service quality will go a long way towards keeping customers happy and loyal, but nothing will retain them forever if the course quality is poor. Educational institutions should maintain the quality for every courses if offers. It has to take a feedback within the organization between the customer service, course development and administrative department (Sales department).

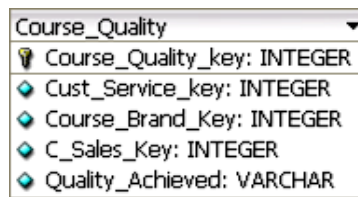

Course_Quality	
Course_Quality_key	INTEGER
Cust_Service_key	INTEGER
Course_Brand_Key	INTEGER
C_Sales_Key	INTEGER
Quality_Achieved	VARCHAR

**Fig.: Data Mart for Course Quality**

### **Call Centre Support**

A call centre is a centralised office used for the purpose of receiving or transmitting a large volume of requests by telephone. An inbound call centre is operated by a company to administer incoming support or information inquiries from consumers. Outbound call centres are operated for telemarketing, solicitation of charitable or political donations, debt collection and market research. In addition to a call centre, collective handling of letter, fax, live chat, and e-mail at one location is known as a contact centre.

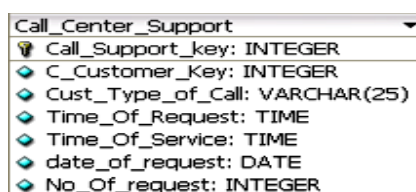

Call_Center_Support	
Call_Support_key	INTEGER
C_Customer_Key	INTEGER
Cust_Type_of_Call	VARCHAR(25)
Time_Of_Request	TIME
Time_Of_Service	TIME
date_of_request	DATE
No_Of_request	INTEGER

**Fig.: Data Mart for Call Centre Support**

## **Trust & Privacy**

Customer private information should be secure. Whether privacy policy is published? Customer should have some choice and control over what information is shared and how it is ultimately used. Personal data should be viewed as an asset to which a company is asking for access, where the customer controls the right to grant or deny that access.

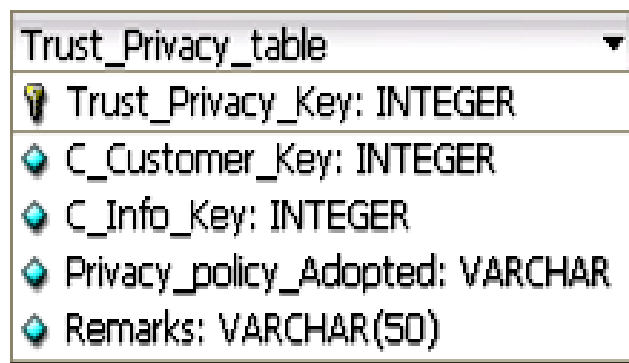

Trust_Privacy_table	
Trust_Privacy_Key	INTEGER
C_Customer_Key	INTEGER
C_Info_Key	INTEGER
Privacy_policy_Adopted	VARCHAR
Remarks	VARCHAR(50)

**Fig.: Data Mart for Trust & Privacy**

## **Experimental Testing**

Verification and validation are two stages within software testing to ensure quality. Verification ensures that a system meets the specified requirements while validation is to demonstrate that a system fulfils its intended use when placed in its intended environment [24]. Verification is about building the model right, while validation is about building the right model [25].

### **Verification**

Verification was conducted by entering the tupuls in the different data marts and checked for the specified requirements. During the development of the data model, the model would be periodically reviewed in the Engineering colleges whether the required decision can be withdrawn from the different data marts.

The reviews are conducted by presenting firstly a justification for technical education conceptual data modelling in Business Intelligence environment; secondly a background on data modelling; thirdly methodology used in this research; and finally the models themselves. While Microsoft PowerPoint was used to present the first three items; the modelling tool, database designer4 was used to present the model.

### **Compatibility of the Existing Work**

The new multi-dimensional model is compared with the existing ER model in the organization and the time efficiency is checked. All the data marts pertaining to customer acquisition and customer retention was checked in the different areas of technical institution data warehouse.

### **Validation**

Validation is conducted in the form of both practical and theoretical usability experiments. Due to the nature of the data available in technical institutions and the area covered by the conceptual model, the new dimensional model could not be implemented in its entirety for validation. A complete implementation would require an unattainable amount of resources, and hence a different approach needed to be taken. A partial implementation was conducted in the different areas of the technical institution.

The data was gathered from a variety of systems in the technical institutions (ERP, Microsoft Access, Microsoft Excel spreadsheets etc.) and the model is checked partially in different areas of the technical institution. The model is checked in each area of the technical institutions and finally it is integrated into one model. The integrity is also checked with the help of different queries.

## **Conclusion**

The importance of data modelling is evident in system development, as it has far reaching consequences on the system design. Within a data warehousing context, data models influence low level factors such as storage space and performance speed, to higher level factors such as the types of analysis that can be conducted.

With an increasing number of systems and data areas, technical institutions are seeking to integrate these areas for advanced data warehouse-styled reporting. An understanding of technical institution data needs to be in place before integration can occur, and this chapter has attempted to provide one stage in developing this understanding.

The conceptual model developed by this research provides an integrated view of technical institution data. By examining data model patterns, standards, information systems, business process models, analysis method, and conducting interviews, a comprehensive model was developed in a business intelligence environment using e-CRM activities.

The types of data available within technical institution data management systems are diverse, and the primary areas identified by this research include: Advertising, Customer Segmentation and Profiling, Campaign Management, Merchandizing, Sales Analysis, Customer Service, Fulfilment, Course Quality, Call Centre Support and Trust & Privacy.

Each of these areas have unique structural elements, and both associative and attributable patterns are clearly evident in their structure. The conceptual data model presents the integration between each area and clearly highlights the interrelationships within technical institution data management. The models are verified through reviews and validated against the different sets of data and checked for the efficiency and integrity.



## References:

- [1] D. Tsichritzis and A. C. Klug, "The ANSI/X3/SPARC DBMS framework report of the study group on database management systems," *Information Systems*, vol. 3, no. 3, pp. 173-191, 1978.
- [2] G. Simsion and G. Witt, *Data modelling essentials*, 3rd ed. San Francisco, CA: Morgan Kaufmann, 2004.
- [3] J. R. Venable and J. C. Grundy, "Integrating and supporting entity relationship and object role models," in *Object-Oriented and Entity-Relationship Modelling*, Gold Coast, Australia, 1995.
- [4] P. Chen, "The entity relationship model - Towards a unified view of data," *ACM Transactions on Database Systems*, vol. 1, no. 1, pp. 9-36, 1976.
- [5] E. F. Codd, *The relational model for database management*. Reading, MA: Addison-Wesley, 1990.
- [6] J. Martin, *Information Engineering*. Englewood Cliffs, NJ: Prentice Hall, 1990.
- [7] T. A. Bruce, *Designing quality databases with IDEFIX information models*. New York, NY: Dorset House, 1992.
- [8] R. Barker, *Case\*Method: Entity relationship modelling*. Wokingham, England: Addison-Wesley, 1990.
- [9] Merriam-Webster, *Merriam-Webster's Collegiate Dictionary*, 11th ed. Springfield, MA: Merriam-Webster, 2003.
- [10] D. C. Hay, *Data model patterns: Conventions of thought*. New York, NY: Dorset House, 1996.
- [11] M. Fowler, *Analysis patterns: Reusable object models*. Reading, MA: Addison-Wesley, 1996.
- [12] L. Silverston, *The data model resource book: A library of universal data models for all enterprises*, 2nd ed. New York, NY: John Wiley and Sons, 2001.
- [13] J. Arlow and I. Neustadt, *Enterprise patterns and MDA: Building better software with archetype patterns and UML*. Boston, MA: Addison-Wesley, 2003.
- [14] P. Coad, *Object models: Strategies, patterns, & applications*, 2nd ed. Upper Saddle River, NJ: Prentice Hall PTR, 1997.
- [15] J. Nicola, M. Mayfield, and M. Abney, *Streamlined object modeling: Patterns, rules, and implementation*. Upper Saddle River, NJ: Prentice Hall PTR, 2001.

- [16] E. Gamma, R. Helm, R. Johnson, and J. Vlissides, *Design patterns: Elements of reusable object-oriented software*. Reading, MA: Addison-Wesley, 1994.
- [17] A. Behm, A. Geppert, and K. R. Dittrich, "On the migration of relational schemas and data to object-oriented database systems," in *International Conference on Re-Technologies for Information Systems*, Klagenfurt, Austria, 1997, pp. 13-33.
- [18] Applied Data Resource Management. *Data Environments* [Online] Available: [http://www.adrm.com/7\\_products.htm](http://www.adrm.com/7_products.htm)
- [19] G. Everest, "Basic data structure models explained with a common example," in *Fifth Texas Conference on Computing Systems*, Austin, TX, 1976, pp. 39-45.
- [20] P. Terenziani, R. T. Snodgrass, A. Bottrighi, M. Torchio, and G. Molino, "Extending temporal databases to deal with Telic/Atelic medical data," *Artificial Intelligence in Medicine*, vol. 3581, pp. 58-66, 2005.
- [21] M. Staudt, A. Vaduva, and T. Vetterli, "Metadata management and data warehousing," University of Zurich, Zurich, Switzerland, 1999.
- [22] ] J. Poole, D. Chang, D. Tolbert, and D. Mellor, *The Common Warehouse Metamodel: An introduction to the standard for data warehouse integration*: Wiley, 2001.
- [23] S. J. Graves, T. H. Hinke, and S. Kansal, "Metadata: The golden nuggets of mining data," presented at the IEEE Metadata Conference, Silver Spring, MD, April, 1996.
- [24] Software Engineering Institute, "Capability Maturity Model® Integration v1.2," Pittsburgh, PA, 2007.
- [25] O. Balci, "Principles of simulation model validation, verification, and testing," *Transactions of the Society for Computer Simulation International*, vol. 14, no. 1, pp. 3-12, March 1997.