

AquaSmart IoT: Advanced Water Quality Monitoring with Sensor and IoT Integration

Dr. S Hema Priyadarshini, Rakshit Preran B, Ashrita Dikshit V A, Poojitha S, Vinay K V,
Department of Medical Electronics Engineering,
Dayananda Sagar College of Engineering, Bangalore, India

ABSTRACT

Water is an essential element for life to sustain. Industrialization is causing the contamination of the potable water and has made it unfit for daily usage. Various cities across the globe have shortage of consumable water. Water from any source must pass fulfill certain standards as per instructed by WHO. We have constructed an inexpensive and an efficient IoT based water quality monitoring system using ESP32 board and Sensors to test the water quality of the collected water samples from various regions in Bangalore city. We have considered three main parameters, namely, Total Dissolved Solids, pH, temperature and turbidity and their respective sensors to measure the same for the collected water samples. The values of TDS, temperature, Turbidity and pH are measured using sensors which are displayed using IoT platform. The obtained values are tabulated, compared with an available water quality monitor and the difference is shown using graphs.

Keywords — *Contamination, temperature, TDS, pH, turbidity, water quality, IoT (Internet of things)*

I. INTRODUCTION

Water exists in many forms, such as liquid, solid, as in snow and ice under the land surface as ground water. Earth comprises of 71% of water, out of which only 2% is in the form of glacier and only 0.05% is found in lakes, rivers, ponds, springs and ground water for human consumption. 60% of human body comprises of water, hence influencing the health of the human. Various deaths have been reported because of consumption of polluted water. Water can be tested for the following parameters:

- Physical parameters that include turbidity, electrical conductivity, temperature, taste, odor, total dissolved solids, and other factors
- Chemical parameters include pH, alkalinity, acidity, hardness, dissolved oxygen and many other factors.
- Biological parameters include algae, bacteria, viruses, and other microbes in the waterbodies. [1]

Water can be classified as Potable water, palatable water, contaminated water and infected water. Due to excess pollution, many different ways have been adopted to distinguish potable water sources from the contaminated water sources. Along with the traditional laboratory testing, the most used water testing method is the “Water Quality Monitor” that can measure the contamination in water bodies by considering the parameters mentioned above. The considered Physical parameters are TDS, Turbidity and Temperature is included in our water quality monitor. As a chemical parameter, pH is included. With the above parameters, biological parameters can be calculated and measured through a mathematical approach. By integrating the device with IoT (internet of things) real time monitoring can be achieved. [2]

TDS or Total Dissolved Solid is the measure of number of particles dissolved in the given volume of solution. TDS is calculated by the electrical conductivity of the given solution. Electrical conductivity is the ability of solution to conduct electricity. The ions of the solids in the water bodies actively participate in conduction of electricity hence can be calculated and considered for the TDS value. It is obtained in ppm (parts per million).

The temperature plays an important role in calculation of biological activity of the water. Studies show that the microbial activity in water samples depends on the water temperature and its surrounding temperature as well. It is measured in °C. [3,4]

The pH or potential of hydrogen is the measure of the hydrogen ion concentration in the given solution. The pH of a given solution decides if it is acidic, basic or neutral in nature. The pH is always reported in “logarithmic units”. Each number between 0-14 shows the 10 times the obtained value.[5]

Turbidity is the cloudiness or haziness of a fluid caused by large numbers of individual particles that are generally invisible to the naked eye. Turbidity of water is measured to know the rate of solid suspended particles in the water. It is measured in NTU (Nephelometric turbidity unit). [6]

The traditional method of water testing used in laboratories include a lot of time to collect and test the water samples and to obtain the report for the same. The traditional method of water testing requires lot of time to prepare the buffer solution and then test it against the freshly collected water samples. Hence, to reduce the time consumption and resources, Water Quality Monitoring instruments were introduced.

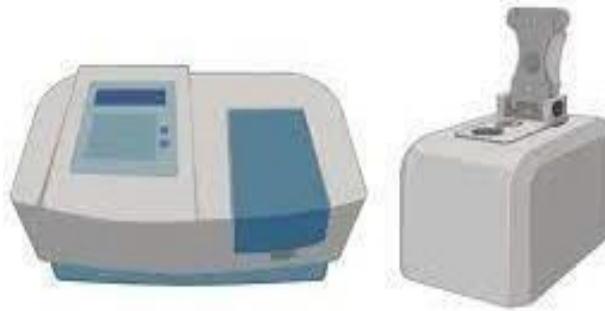

Fig.1. Spectrophotometer

Figure (1) shows an instrument called spectrophotometer which can be used to measure water quality. A spectrophotometer measures the wavelength of the parameters alongside with the standard solution to give the results. Spectrophotometry is a method to measure how much a chemical substance absorbs light by measuring the intensity of light as a beam of light passes through sample solution. The basic principle is that each compound absorbs or transmits light over a certain range of wavelength. The wavelengths and frequencies of sample and the standard solutions are then compared side by side for monitoring the contents present in the sample solution.

One such available water quality monitoring instrument is “Pensor 1.75” by the company Envisensai. The instrument connects to an app via Bluetooth and provides the result instantly. The instrument has several sensors including pH, turbidity, Temperature and TDS. With these parameters other parameters like BOD, COD, DO, hardness, etc. can be calculated.

The instrument works on pure machine learning algorithms programmed using python programming language and displays values via app. The device has an 800mAh lithium battery to recharge the device frequently with a USB C-type cable and a LED light to indicate the charge of the battery. The operating temperature is mentioned as 10° C to 50° C, can handle a voltage of 5V and a current of 2 Amps. The device also has a low energy Bluetooth module.

II. METHODOLOGY

The quality of water is assessed by measuring the physical parameters TDS, temperature, turbidity and the chemical parameter pH of the water collected from different sources. The standard values for the chosen parameters are:

- TDS: 0 – 300 ppm
- Temperature: 22 °C – 27 °C
- Turbidity: 0.0 – 1.0 NTU
- pH: 6.5 – 8.2

Components – Components used in the device are ESP32, analog gravity TDS circuit, analog gravity Turbidity circuit, analog gravity pH circuit and temperature sensor integrated with ThingSpeak IoT platform.

Details about the components:

1. TDS sensor and TDS meter – The sensor senses the ionic voltage of a solution and then the electrical conductivity is measured through it. The sensor is converts the electrical conductivity and provides the TDS value. It supports 3.3 - 5V input voltage and 0 ~ 2.3V Output Voltage making it easy to be compatible with all Arduino Boards. The sensor has a measuring range of 0 ~ 3000 ppm with an accuracy of $\pm 2\%$. The probe is of diameter 6.35 mm and is water proof. The sensor is accompanied by a PCB board (TDS meter) to control operations individually. [7]

2. Temperature sensor – The sensor is a direct to digital temperature sensor. It requires only one data line (and GND) to communicate with the Arduino and can draw supply through it in its Parasite mode. The sensor is always supported by a 4.7k Ω resistor. The sensor supports 3 – 5.5V of supply voltage. The provided range is about -55 to 125 ° C with an accuracy of ± 0.5 ° C. The sensor has a temperature limit alarm system built into it. [8]

3. Turbidity sensor - Turbidity Sensor is able to detect and verify the quality of the water, making the turbidity measurement, where it is possible to verify the results by means of digital or analog signal next to the corresponding pins in the accompanying electronic module. The sensor operates on the principle that when the light is passed through a sample of water, the amount of light transmitted through the sample is dependent on the amount of soil in the water. As the soil level increases in the water sample, the amount of transmitted light decreases. It supports a voltage of DC voltage of 5V with maximum current of 30mA. The range provided by the sensor is around 0 ~ ± 1000 NTU with an accuracy of ± 1 NTU.

4. pH sensor and pH meter - It has an LED that works as the Power Indicator, a BNC connector, and a PH2.0 sensor interface. The sensor is powered by an external voltage of 5V. It measures a range of 0 ~ 14 with an accuracy of ± 0.01 pH. The sensor needs to be calibrated frequently for accurate results in a standard solution of pH 7. After the calibration, the sensor can be used directly or can be recalibrated for better results. To measure an alkaline solution the alkaline calibration is used where the sensor is calibrated in a standard solution of pH value is 9.18. [9,10]

5. ESP32 board – The ESP32 board was designed by “Espressif” systems and are low cost with low power consumption. It is a 32-bit microprocessor. The board has inbuilt Wi-Fi and Bluetooth modules which makes it better than Arduino boards which requires an external Wi-Fi and Bluetooth modules. It has 48 pins of which 36 are GPIOs. The operating voltage is around 2.2 - 3.3V.

6. ThingSpeak cloud - ThingSpeak is an open source IoT analytics platform service that allows you to aggregate, visualize, and analyze live data streams in the cloud. You can send data to ThingSpeak from your devices, create instant visualization of live data, and send alerts.

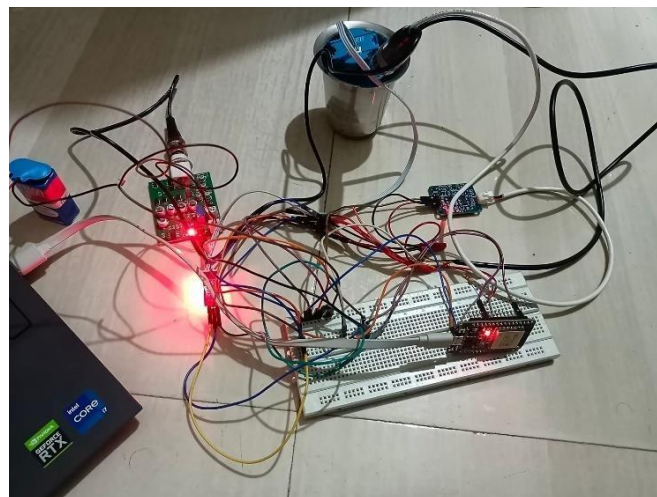

Fig.2. Circuital setup

The above figure (2) shows circuital setup for the water quality monitor. The sensors of the chosen parameters are interfaced to IoT platform for better understanding of the obtained readings and record it in the form of graph through the ESP32 board. The circuital setup combines sensor technology, microcontroller processing for interfacing and IoT communication to create a communication to create a comprehensive water quality monitoring system. It enables efficient and continuous monitoring of parameters.

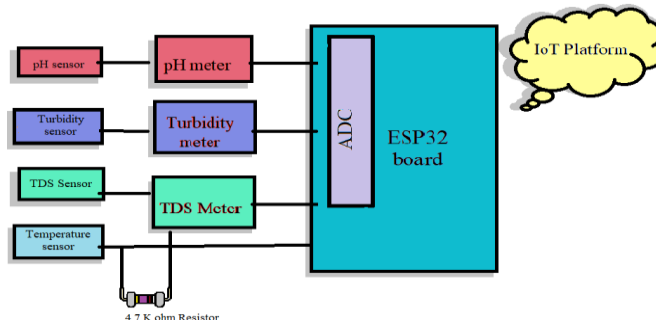

Fig.3. Block diagram

The above figure (3) shows the block diagram of the water quality monitor. The sensors chosen are exposed to the water samples collected from the regions of Bangalore. The sensors contain two electrodes, anode and cathode. When the voltage passes from anode to cathode, the ions present is measured. The voltage is then converted to an analog signal by the sensor. The signal is then passed to ESP32 board which in turn converts the signal to Digital signal by using ADC. The obtained data is sent to ThingSpeak platform via Wi-Fi. The data in ThingSpeak is shown in the form of graph and compared with the data obtained from the commercially available water quality monitor.

The total dissolved solids of a given water sample is calculated by measuring the conductivity of the water sample. Conductivity is the measure of conduction of electricity of the solution. Since TDS measurement consumes more time, TDS is preferably calculated by conductivity of the solution using the formula

$$\text{TDS (mg/L)} = k_e \times \text{EC } (\mu\text{S/cm}) \dots\dots\dots (1)$$

Where, k_e is a constant of proportionality/ correlation factor, $k_e = 1000 / 2 = 500$

EC is the electrical conductivity

The value obtained is in terms of voltage (mV). Hence, the value is converted to the pH value by a formula given below

$$\text{pH} = 7 - (V/57.14) \dots\dots\dots (2)$$

Here, -57.14 is the current supply voltage in mA

V is the voltage obtained by the sensor in mV.

The code was designed using C ++ programming language through Arduino IDE software and is uploaded to the ESP32 board.

III. RESULTS AND DISCUSSION

Tap water samples were collected from various regions in and around Bangalore city and tested. The values were tabulated as follows and conclusion was drawn regarding the water consumption. The obtained values of TDS, temperature, turbidity and pH were plotted in graphs. The Output values were obtained on the ThinkSpeak cloud. The below table show the values of the water quality monitor.

Procedure of collecting the samples – The water from the bore wells in the above chosen areas was first collected in the main tank with the help of the pump. The pipe in the water drum was allowed to run for 5-10 minutes and then the water samples were directly collected from the pipe. The collected water was tested on the same day to avoid bacterial growth or cross contamination.

Sampling sites considered for testing:

- 1- Borewell water from Kumarswamy layout
- 2- Borewell water from Nagarabhavi
- 3- Borewell water from Mahalakshmi layout
- 4- Borewell water from Sanjaynagar
- 5- Borewell from Hanumanthnagar

Table 1: Values obtained from the Pensor

sl. no	TDS (In ppm)	Temperature (in ° C)	Turbidity (High/Medium/Low)	pH	Inference
1	314.90	28.75	Low	7.26	Very Poor Do not Drink
2	300.40	27.8	Low	7.08	Very Poor Do not Drink
3	305.33	28.03	Low	6.97	Very Poor Do not Drink
4	314.55	26.55	Low	7.16	Very Poor do not Drink
5	309.64	25.84	Low	7.04	Very Poor Do not Drink

Table 2: Values obtained from the Water Quality Monitor

sl. no	TDS (In ppm)	Temperature (in ° C)	Turbidity (in NTU%)	pH	Inference
1	315.0	28.75	5	7.26	Non consumable
2	300.80	27.8	4	7.08	Non consumable
3	305.33	28.03	1	6.97	Non consumable
4	314.13	26.55	4	7.16	Non consumable
5	309.68	25.84	2	7.04	Non consumable

The above table 1 gives the values of commercially available water quality monitoring device for the collected water samples. Table 2 gives the values of the developed water quality monitor for the collected water samples. The following inferences are obtained in comparison of designed and commercially available water quality monitor:

1. TDS – The TDS value shows that the samples are beyond 300ppm which is not suitable for consumption. The difference between the obtained value and the measured value is around ± 0.1 ppm. The difference is seen due to the device calibration, usage, the model (company of manufacturing), and other factors. The TDS value majorly depends on the salts present in the water samples. The graphs below show the comparison of the values.

2. Temperature – The temperature values depend on the surrounding air temperature. Temperature affects the microbial growth in the water source. The temperature as seen is around 26.5 ° C in average which lies in the room temperature. The water in room temperature may carry a few beneficial bacteria which are good for consumption. The value hence provided by both Pensor and the water quality monitor can be concluded as consumable in terms of temperature alone.

3. pH – The pH value shows that the water is neutral and chemically safe for drinking. The pH values are between the neutral pH, that is, between 6.5 to 8.2. The average pH value is 7.4 which shows that the values are neutral and is safe to be consumed. The pH depends on the carbonates and bicarbonates present in and around the water supply pipes and as in salts in the supplied water.

4. Turbidity - The Turbidity shows the cloudiness of water. The turbidity was Low when tested with the Pensor device which means that the turbidity is below 1NTU. In the water quality monitor, the measured Turbidity value is shown to be below 1.0 NTU or 100% NTU. This means that the water is clear and there are no such turbid conditions in the water. The turbidity of water depends on the soil and gravel content present which may be due to construction sites or landslides or unsanitary pipes or even leakage in pipes which supply water.

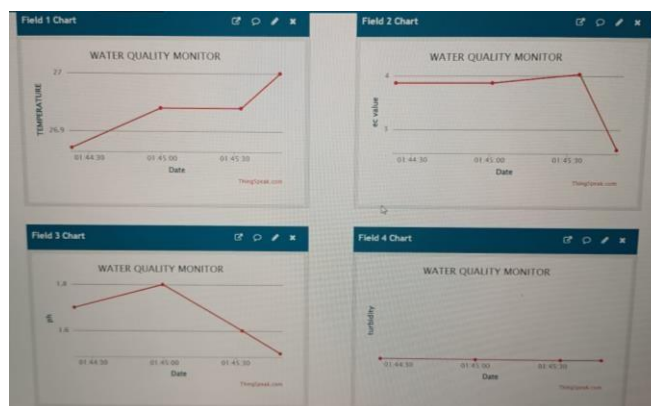

Fig.4. Graphs on IoT platform

The above figure (4) shows the graphs plotted on the IoT platform. We can observe the variation in the values of the considered parameters in the above graphs. This may be due to increase in level of toxic substances like nitrites or lead which are both considered to be the byproduct in industries and even in construction sites. Usage of high chlorine level during water treatments can also cause spike in TDS levels. The pH variation is caused due to influence of surrounding carbonate contents while supplying the water through pipes below the earth. The temperature of the samples is affected by the surrounding air temperature and humidity of the particular day. The turbidity units change due to solid suspensions like soil or gravel present in water supply pipes, or due construction sites. The values show that the water is suitable for daily usage like washing clothes, vessels or daily household chores, but it is not suitable for drinking.

IV. CONCLUSION

Monitoring drinking water is essential and with increase in various diseases the demand for potable drinking water has increased for a healthy lifestyle. The recent industrial revolutions have caused a lot of pollution which in turn has created a demand for the safe drinking water. Hence, water Quality Monitor is essential to identify the level of pollution in the water source, indicating whether the water is drinkable. TDS, turbidity, temperature and pH are important parameters to indicate the contamination of the provided water sources. TDS measures the dissolved ions in the water bodies and pH indicated the acidity or basicity nature of the water source. Turbidity is the clearness of the water and the hotness or coldness of a water body is indicated by its temperature which also helps in monitoring the biological activities in water.

Various samples were collected from different places in Bangalore city, and were tested using TDS and temperature sensors. The pH was tested using pH paper for Hydronium ion concentration. The readings were obtained on ThinkSpeak cloud platform and monitored using ESP32 board.

The TDS value alone showed that the water is not consumable due to its high ionic levels. The TDS was above 300ppm which means that the water is contaminated and has high amount of salt content in it. The turbidity of water samples was low and were crystal clear. Hence the turbidity can be concluded as below 1 NTU as considered by the Water board in India.

The temperature of the collected water samples was around the room or air temperature of the samples collected on that particular day. The temperature supports microbial growth. At room temperature, the water has beneficial microbes which enhance human health. Lower the temperature, higher the microbial growth till the freezing point, higher temperatures kill microbes either beneficial or non-beneficial.

Whereas as concerned to the pH, water samples showed neutral state (7) of pH which is advisable to drink. pH of water below 7 is acidic and above 7 is basic. But according to the Department of drinking water and sanitation, water between the pH of 6.5-8.2 is recommended for drinking.

Hence, the water samples collected showed that can be used for day-to-day activities. The water cannot be used for drinking purposes without treating the TDS. The water can be either treated for its hardness and to remove salts by boiling the water or filtering the water using water purifiers, which is a common household appliance in recent times, for safer drinking water.

REFERENCES

- [1] Umair Ahmed Rafia Mumtaz; Hirra Anwar; Sadaf Mumtaz; Ali Mustafa Qamar “Water quality monitoring: from conventional to emerging technologies”, 2019, *WaterSupply*, Vol 20 (1): 28–45.
- [2] R. Moparthy, C. Mukesh and P. Vidya Sagar, “Water Quality Monitoring System Using IOT”, 2018, Fourth International Conference on Advances in Electrical, Electronics, Information, Communication and Bio-Informatics (AEEICB), Chennai, pp. 1-5.
- [3] Dimkić, D, Slimak, T, Radenković, “Correlation between Average Daily Temperatures and Production of Water in Water Supply Systems”, International Conference Climate Change Impacts on Water Resources: Belgrade, Serbia, 2013; pp. 153–160.
- [4] Dejan Dimkić, “Temperature impact on drinking water consumption”, *Environ. Sci. Proc.*, Presented at the 4th EWaS International Conference: Valuing the Water, Carbon, Ecological Footprints of Human Activities, Online, 24–27 June, 2020.
- [5] “A comparative study on measurement of pH of water, using pH meter and water testing kit”, *IIARD-International journal of applied Chemistry*, 2015, Vol. 1 No.3.
- [6] Vincent Gauthier, Benoit Barbeau, Geneviève Tremblay, Robert Millette, "Impact of raw water turbidity fluctuations on drinking water quality in a distribution system", 2018 *Journal of Environmental Engineering and Science*
- [7] Yuda Irawan, Anita Febriani, Refni Wahyuni, Yesica Devis, “Water Quality Measurement and Filtering Tools Using Arduino Uno and TDS Meter Sensor”, *Journals of Robotics and Control*, 2021, Organized by Peneliti Teknologi Teknik Indonesia, Indonesia, Published by Universitas Muhammadiyah Yogyakarta in collaboration with Peneliti Teknologi Teknik Indonesia, Indonesia, Vol. 2, No 5.
- [8] Carolina Calero Preciado, Joby Boxall, Víctor Soria-Carrasco, Isabel Douterelo, “Effect of temperature increase in bacterial and fungal communities of chlorinated drinking water distribution systems”, 2019, *Access microbiology*, Microbiology Society, Volume 1, Issue 1.
- [9] Claudia Manjarrés, David Garizado, Maria Obregon, Natalia Socarras, Maria Calle, Cecilia Jimenez Jorquera, “Chemical sensor network for pH Monitoring”, 2016, *Journal of applied Research and Technology*, Vol 14, No 1.
- [10] Asmita Ashok Pakale, Pratibha Tanaji Jadhav, Pranali Dilip Jadhav, “DIGITAL PH METER”, 2018, *Journal of Electronic Design Engineering*, Vol 4, No 1-2