

# **DRONE WITH ROBOTIC ARM**

## **Introduction**

An aircraft without a human pilot on board is referred to as an unmanned aerial vehicle (UAV) or drone. The aircraft can be remotely controlled or can fly autonomously through software-controlled flight plans in their embedded systems working in conjunction with onboard computers. The technology for drones is improving every day. Drones are now also used in a wide range of civilian roles ranging from search and rescue, surveillance, traffic monitoring, weather monitoring and firefighting to personal drones and business drone-based photography, as well as videography, agriculture and even delivery services. To increase the drone's utility in emergency situations and to make it more efficient, we are demonstrating a drone using robotic arm, the robotic arm is constructed in a manner that lifts a 2kg weight and with the wireless control of arm to safely drop the payload in the intended location in the case of a flood or other natural disasters. To put it to effective use in a condition of emergency, we are going to design a robotic arm for drone. One of the applications includes emergency transportation. Medicines are typically lightweight but are extremely valuable in terms of their impact on the health of global populations, thus making these items a potential focus for the development of drone-based delivery solutions. The main function of the arm is to lift and drop the payload. It provides vehicle lift and can be piloted remotely, can be expandable or recoverable, and can carry a lethal or nonlethal payload. In this instance, a drone is capable of lifting 2kg, making it useful for carrying emergency medications as well as food during floods. That also safely launches the payload at the destination.

## LITERATURE REVIEW

### General Introduction

A literature survey is a fundamental practice, to understand and develop an idea. A literature survey not only summarizes the knowledge of the area or field but also gives us an idea of what had to be done. In the following section, we discuss the issues and works related to drone related work and its applications in several sectors.

### Literature Survey

**Aerial grasping of cylindrical object [1]** It was proposed by Hoseong Seo. This paper concentrates on design of a vision-based guidance command for aerial manipulation of a cylindrical object. This paper focused only on the utilisation of cylindrical items. The positioning of the arms in this document makes flying the drone difficult.

**Drone applications in transportation [2]** It was proposed by Drazen Cvitanic. The author emphasises the numerous applications of UAVs for improving and facilitating transportation difficulties, as well as for planning, designing, and monitoring transportation and other infrastructure. Their application could be critical in the transportation of goods in medical supply. There is no suitable lifting mechanism.

**Development of a Drone-Supported Emergency Medical Service [3]** This paper aims to investigate the use of drones in as an EMS to improve response times. To develop a specific procedure to keep the number of drones at a minimum level under the constraint of the minimum intervention time. The proposed model has been applied to a real EMS case for a city in the south of Italy.

**Drone design for first aid kit delivery in emergency [4]** This paper tells Automated drones which deliver personalized first aid kit to the user location so that the victim can be diagnosed by the remedy medicines with assistance of doctor using web app till the ambulance arrives to the victim location and takes the victim to hospital. Users can also request pharmacy for immediate remedy medicines in case of emergency.

**Detecting anomalous activities in spatio-temporal region anomaly [5]** This paper elaborates detection system using Machine Learning helps to detect the anomalies like accidents etc. Detecting anomalies in videos is important but it is an unsolved problem. This system will automatically detect the anomaly by image analysis from the surveillance videos. This system is capable of tracking abnormal event in each frame and generates a notification of such event. The proposed K-means algorithm performs existing anomaly detection techniques, while being comparatively time efficient.

The above-discussed papers presented us with a broad perspective on how to tackle what we have aimed for and gave us the different possible approaches to follow to build our project i.e., Drone with robotic arm.

## **Problem Statement and Objectives**

### **Problem Statement**

Transporting necessities like food, water, and medication over land can be exceedingly difficult or even impossible in an emergency circumstance like a flood, landslide, or other natural disaster. Roads may be blocked or completely flooded away, bridges may be hazardous, and infrastructure may be destroyed or damaged. This may result in significant shortages of requirements, putting the communities in consideration at risk for several health and safety hazards.

### **Objectives**

The core objective of this project is to design robotic arm for drone and increase its application in emergency transportation. That can also lift 2kg of payload with wireless control of arm and drop the payload to its intended location.

## Methodology

Figure 1 shows the block diagram of robotic arm. Two servo motors are used to control the arm. The various actions of arms are controlled by Arduino uno. NRF24L01 transceiver is used for the wireless control of servo motors. The joystick value is mapped to a buffer, the angle is specified in the program including the value of joystick (0-1023). This value will be received by the receiver end Arduino uno and maps the value to servomotor.

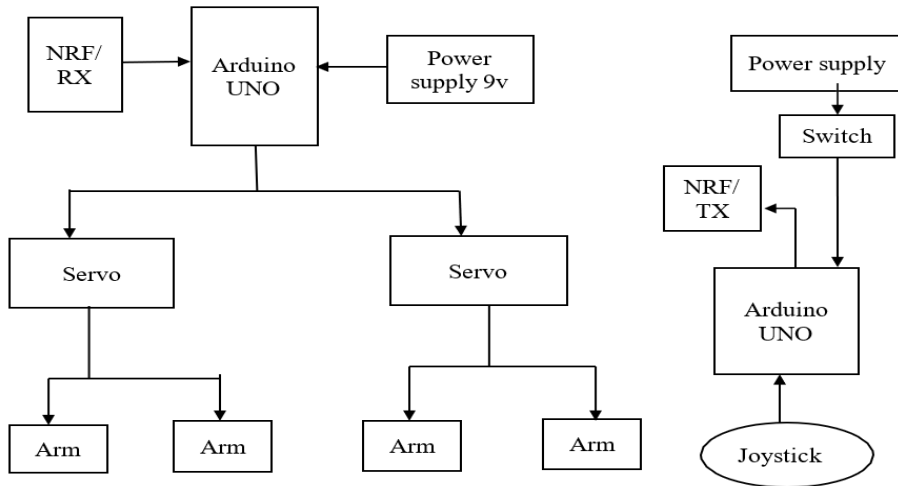

Figure 1: Block diagram of robotic arm

### 3D Design of Robotic arm

The 3D printed arm was designed in Tinker cad, a free online CAD software. The arm was designed with a focus on versatility and strength, with the ability to lift payloads upto 2kg. The arm was created using a 3D printer with PLA material, which is a widely used thermoplastic material known for its strength and durability. The arm was printed with an infill of 50%, which refers to the amount of material inside the printed object. This infill percentage provides a balance between strength and weight, making the arm robust while keeping it lightweight. The arm's design allows for easy attachment to the two MG995 servomotors, which are used to control the arm's movement. The 3D printed arm is a key component of the project, enabling lifting of payloads.

### Interfacing of robotic arm

**Designing the Arm:** The first step in the project was to design the arm using Tinker cad software. The design focused on versatility and strength, and the arm is created with multiple interconnected parts to enable smooth and precise movement. The design was optimized for 3D printing and included cable routing for neat and efficient cable management.

**3D Printing the Arm:** After the design was finalized, the arm was 3D printed using PLA material with an infill of 50%. The 3D printing process is carefully monitored to ensure the accuracy and precision of the printed parts. After printing, the parts were carefully removed from the printer bed and assembled according to the design. **Attaching the Servomotors:** The next step was to attach the two MG995 servomotors to the arm. The servomotors were mounted to the base of the arm and connected to the various arm segments using screws and brackets. The servomotors were also connected to the Arduino UNO using jumper wires.

Wireless Control: The arm was controlled wirelessly using a joystick and NRF wireless communication modules. The NRF modules were connected to the Arduino UNO using jumper wires, and the joystick was connected to the second Arduino UNO.

Testing: The final step in the project was to test the arm and control system. The arm was tested to ensure its ability to lift payloads up to 2kg and its precision in movement. The control system was also tested to ensure its reliability and accuracy. The project was tested and demonstrated successfully, and the arm was shown to be versatile and precise, making it an ideal candidate for use in a variety of applications.

In summary, the methodology for the project involved designing and 3D printing the arm, attaching the servomotors with their respective pin configurations, implementing a wireless control system with NRF modules and a joystick with their respective pin configurations, and testing the arm and control system for accuracy and precision. The methodology enabled the successful development of a versatile and precise arm for use in a variety of applications.

## System Requirements

### Hardware Requirements

#### Arduino Uno

The Arduino Uno is a microcontroller board that is free source. The ATmega328P microprocessor powers the Uno, which includes 32KB of flash memory, 2KB of SRAM, and 1KB of EEPROM. There are 14 digital input/output pins on the board, six of which can be utilized as PWM outputs, and six analogue inputs. It also includes a reset button, an ICSP header, and a USB port. The Uno can be charged through USB or via an external power supply. The recommended voltage range is 7-12V. The Arduino Software (IDE), which is based on the Processing programming language, is used to program the Arduino Uno. It supports the programming languages C and C++. Figure 2 shows picture of Arduino uno.

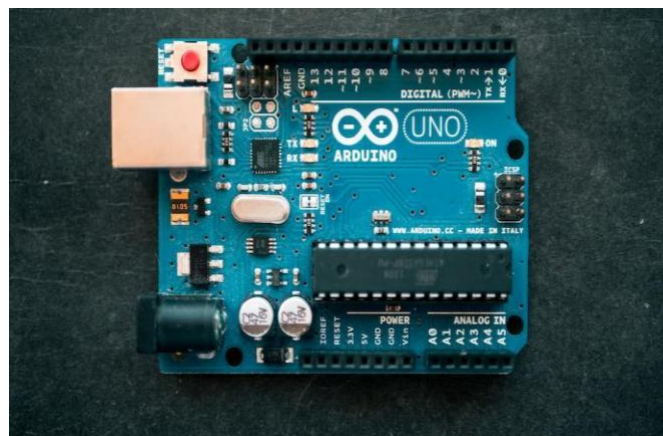

Figure 2: Arduino Uno

#### NRF24L01

The NRF24L01 is a well-known low-cost wireless transceiver module that runs at 2.4 GHz. It's common in wireless communication applications like remote control systems, wireless sensor networks, and industrial control systems. The module is built around the Nordic Semiconductor nRF24L01+ chip, which enables reliable wireless communication while consuming little power. The NRF24L01 module has an open-space range of up to 100 meters and can communicate with other NRF24L01 modules in either a point-to-point or multi-point mode. The module has a maximum data rate of 2 Mbps and supports multiple.

channel. Figure 3 shows the picture of nrf24l01.



Figure 3: Nrf24l01

### **Joystick**

A joystick is an input device that is often used in a digital environment to control the movement or direction of a cursor, object, or device. It is made from a handheld stick or lever that can be moved in any direction, as well as extra buttons for controlling other operations. Joysticks are extensively employed in video games, flight simulators, and other applications that need precise movement control. They can also be used to control machines in industrial environments, such as cranes or robots. Depending on its intended application, joysticks can come in a variety of shapes and sizes. Some are intended to be held in one hand, while others are intended to be installed on a desk or panel. Figure 4 shows the picture of joystick.



Figure.4: Joystick

### **Servomotor (MG995)**

The MG995 servo motor is a type of rotary actuator that is commonly used in various applications, such as robotics, automation, and remote-control systems. It is a high-quality servo motor that provides precise control of angular position, speed, and acceleration. The MG995 servo motor features a metal gear train, which makes it highly durable and able to withstand high torque loads. It also has a high torque output, with a maximum stall torque of around 10 kg-cm, and a voltage range of 4.8V to 7.2V. The motor can rotate up to 180 degrees, and it includes a feedback potentiometer that provides position feedback to the controller. Figure.5 shows the picture of MG995 servo motor.



Figure 5: MG995 Servo motor

### **3D printed model**

A 3D model of a robotic arm using PLA material with 50% infill would result in a sturdy and strong arm that can effectively perform its intended functions. PLA (Polylactic Acid) is a widely used 3D printing material that is known for its strength and durability. It is a biodegradable and eco-friendly plastic. The 50% infill refers to the amount of material that is used to fill the interior of the arm. The infill density affects the strength and weight of the 3D model. A higher infill density results in a stronger and heavier model, while a lower density results in a lighter and less durable model. A 50% infill density is a good compromise between strength and weight. Figure 6 shows the picture of 3D printed arm.



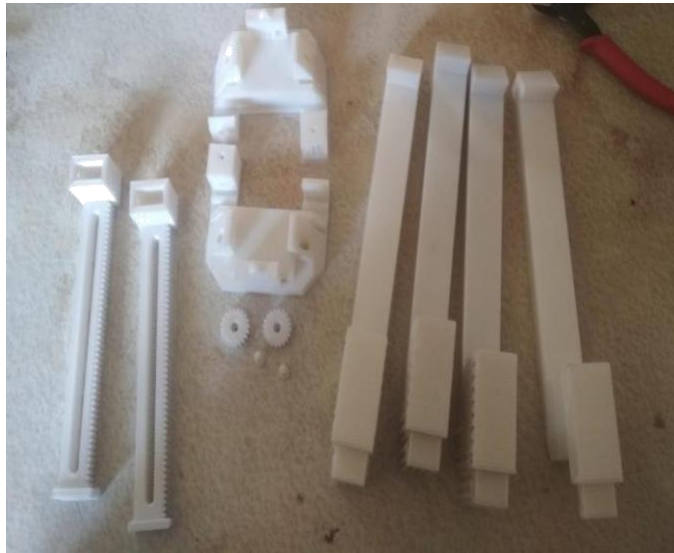

Figure .6: 3D printed arm

### **Power supply**

A 9V DC power supply is a device that provides a constant and stable direct current (DC) voltage of 9 volts. It is commonly used to power electronic devices that require a 9V DC power source, such as musical instruments, effects pedals, routers, modems, and other small appliances. Figure.7 shows the picture of 9v battery.



Figure 7: 9v battery

## Software Requirement

Software required for implementation of the model are as follows

### Arduino IDE

The Arduino IDE (**I**ntegrated **D**evelopment **E**nvironment) is an open-source software, which is used to write and upload code to the Arduino boards. The user interface of Arduino ide is shown in figure 8. The IDE application is suitable for different operating systems such as **Windows, Mac OS X, and Linux**. The program or code written in the Arduino IDE is often called as sketching. We need to connect the Arduino board with the IDE to upload the sketch written in the Arduino IDE software. The sketch is saved with the extension '.ino.'. The editor has features for cutting/pasting and for searching/replacing text. The message area gives feedback while saving, exporting and displays errors. The console displays text output by the Arduino Software (IDE), including complete error messages and other information. The bottom right hand corner of the window displays the configured board and serial port. The toolbar buttons allow you to verify and upload programs, create, open, and save sketches, and open the serial monitor.

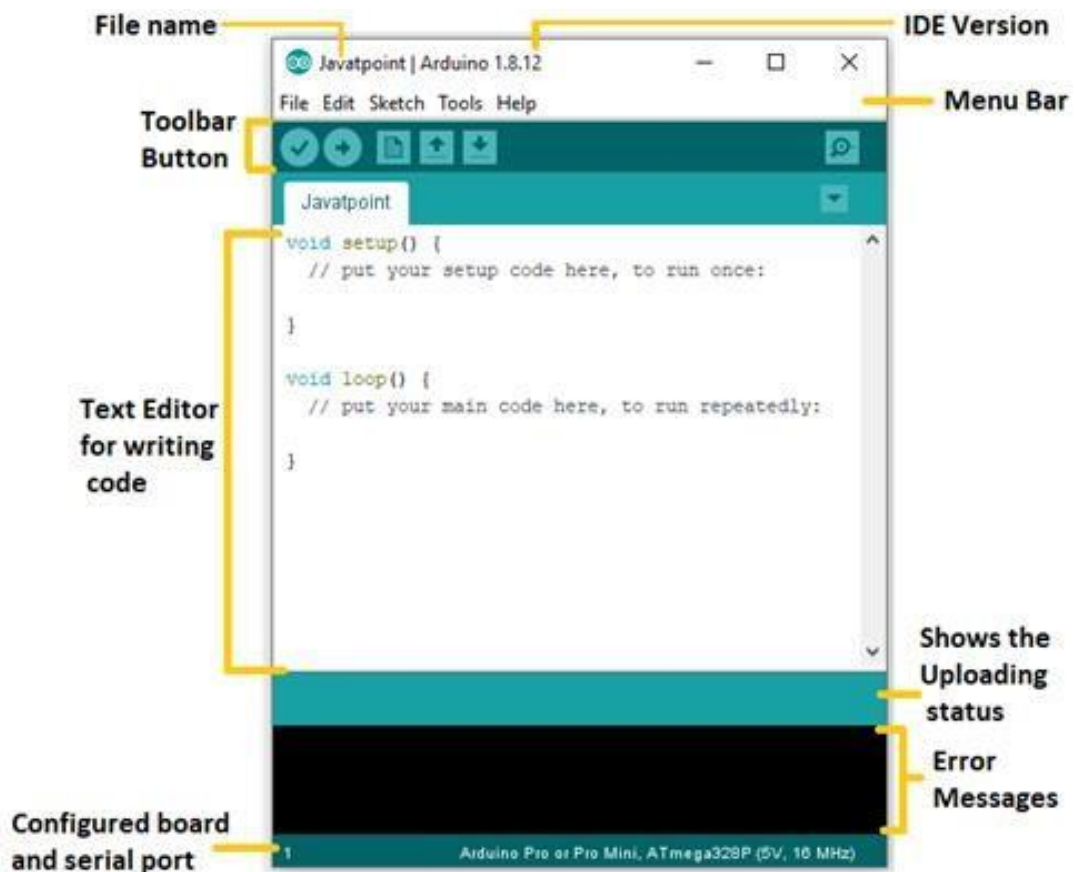

Figure.8: User Interface of Arduino IDE

## Tinkercad

Tinkercad is an online collection of software tools from Autodesk that enable complete beginners to create 3D models. User interface of the software is shown in figure.9 This CAD software is based on constructive solid geometry (CSG), which allows users to create complex models by combining simpler objects together. As a result, this 3D modelling software is user-friendly and currently enjoyed by many, particularly teachers, kids, hobbyists, and designers. Best of all, it's free and only requires an internet connection. The software allows users to create models that are compatible with 3D printing. It is based on CSG to create solid models; one can always make models more complex by adding more shapes. The 3D models can be saved in three different formats, STL, OBJ, and SVG. Once STL file of the model is obtained, one can go on tousing slicing software i.e., dividing the object into a stack of flat layers and describing these layers as linear movements of the 3D printer extruder.

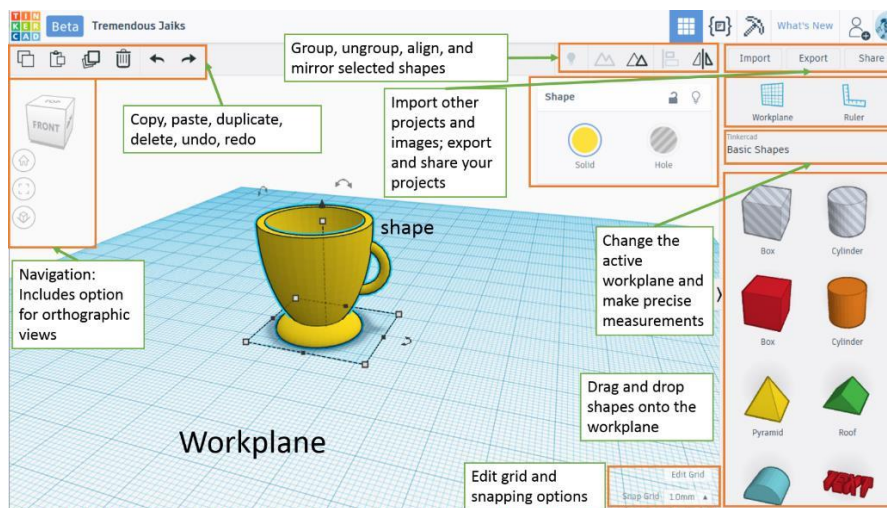

Figure.9: Tinker cad User Interface

## Flash Print

The act of converting a 3D model into a set of instructions for the 3D printers is called **Slicing**. It 'slices' the 3D model into thin layers, and determines how each layer should be printed (the tool path) to get minimum time, best strength, etc. A slicersoftware takes a 3D CAD model which is generally an **STL format file** and converts it into a **g-code** that gives commands to the printer. Following are the three major types of settings that can be controlled in a slicer software:

- Print Settings: layer heights, shells, infill per cent, and speed.
- Filament Settings: filament diameter, extrusion multiplier, the temperature of the extruder, and print bed.
- Printer settings: nozzle diameter, print bed shape (L x W), and Z offset.

Flash print is the slicing software used for the Flash Forge printer. User interface of the software is shown in figure 10. Flash print will slice the 3D model into numerous layers and output it as a '.g' file, which is the format read by the Dreamer. The file is then transferred to the printer by USB cable, SD card, or Wi-Fi. Once the output file has been transferred to the printer, it will start to turn the 3D model into physical object by laying down layers of filament.

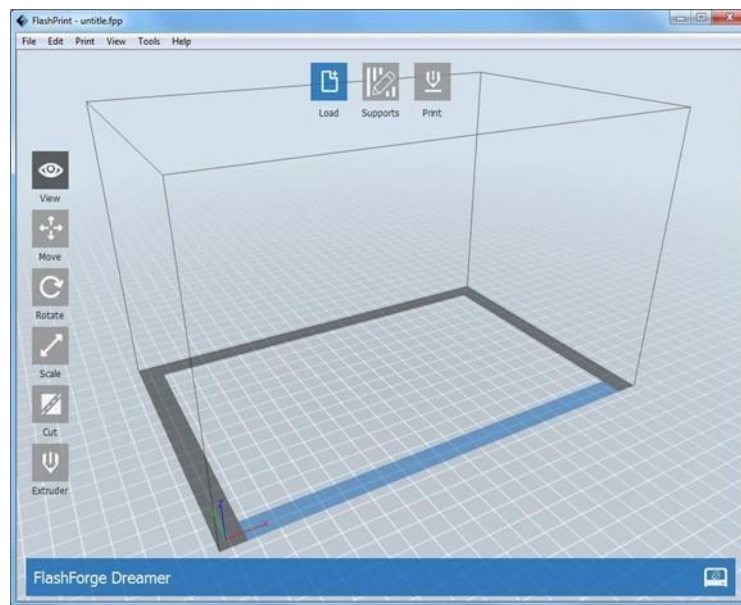

Figure.10: User Interface of Flash Print

## Flow chart and algorithm of Transmitter

This section discusses about algorithm and flow chart for transmitter and receiver of robotic arm.

Flow chart of transmitter:

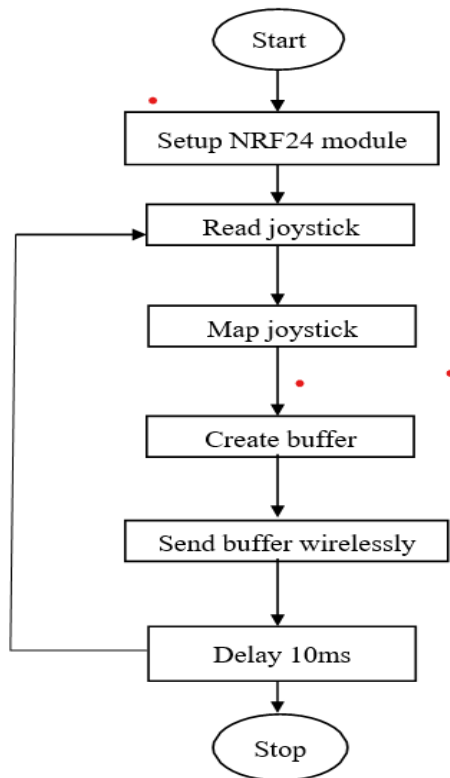

Figure .11: Flow chart of transmitter

### Algorithm of transmitter:

Step 1: Start

Step 2: Set up the NRF24 module by calling its begin()

Step 3: Read the current position of the joystick X and Y axes using the analogRead() function.

Step 4: Map the joystick values to a range of 0 to 255 using the map() function.

Step 5: Create buffer of type char with a length of 2 bytes.

Step 6: Assign the mapped joystick values to the first and second elements of the buffer.

Step 7: Send the buffer wirelessly using the NRF24 module's write() method.

Step 8: Wait for a short period of time using the delay() function before sending more data.

Step 9: Repeat steps 2 & step 7 indefinitely.

Step 10: Stop

## Flowchart and algorithm of receiver

### Flowchart of receiver:

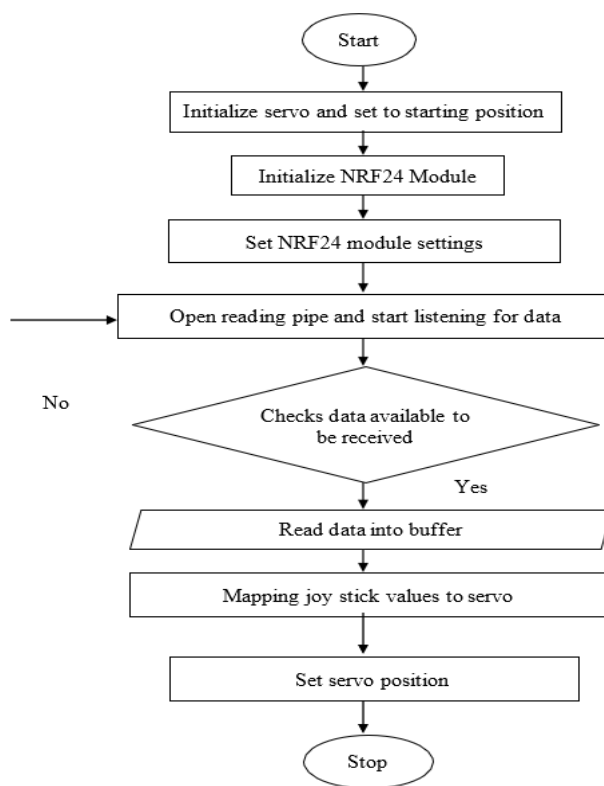

Figure.12: Flowchart of receiver

**Algorithm of receiver:**

Step 1: Start

Step 2: Initialize the NRF24 module and configure its settings.

Step 3: If data is available read the data into a buffer using read function of the RF24 object.

Step 4: Convert the buffer data to integer values.

Step 5: Map the joystick X values to a range of 0 to 180 to get the servo position.

Step 6: Set the servo position to the mapped value using the write function of the servo object.

Step 7: Repeat steps 2 to 6 to continuously check for incoming data and update the servo position accordingly.

Step 8: Stop

**Circuit connection:**

Figure.13 represents the circuit connection for the transmitter using Arduino Uno, a joystick, and an NRF24L01 module. Arduino Uno serves as the main microcontroller board for the transmitter circuit. NRF24L01 module is used for transmission of data from the joystick to the receiver. The joystick is an input device used to control the movement of the robotic arm.

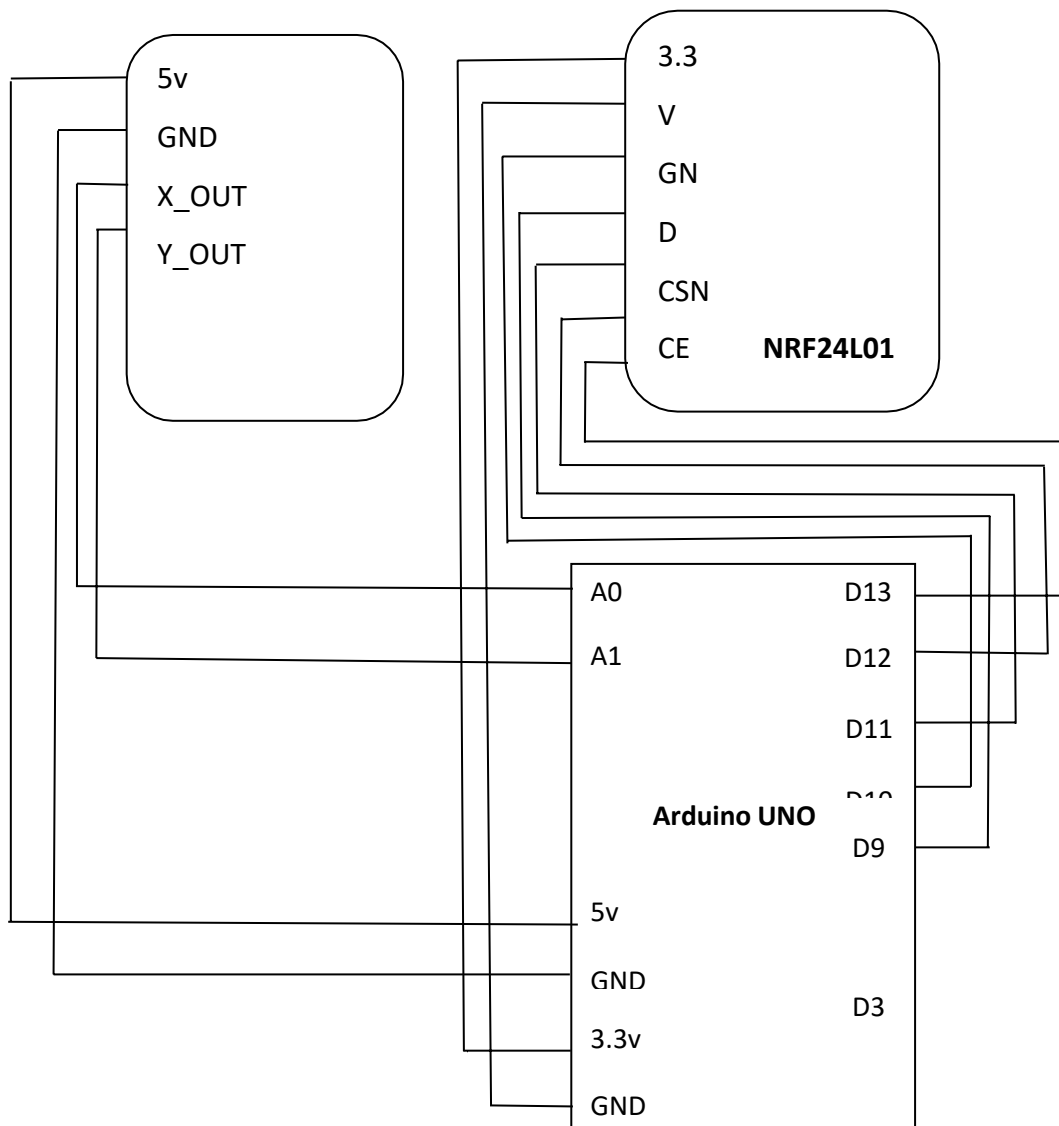

Figure .13 Transmitter Circuit connections

Figure 14 shows the connections of receiver using Arduino UNO , NRF24L01 module and Servo motors. Arduino Uno receives wireless data from the transmitter and controls the servo motors. The NRF24L01 module is responsible for receiving the wireless data transmitted by the transmitter. The two servo motors are used to control the movement of the robotic arm. They receive control signals from the Arduino Uno and adjust their position accordingly.



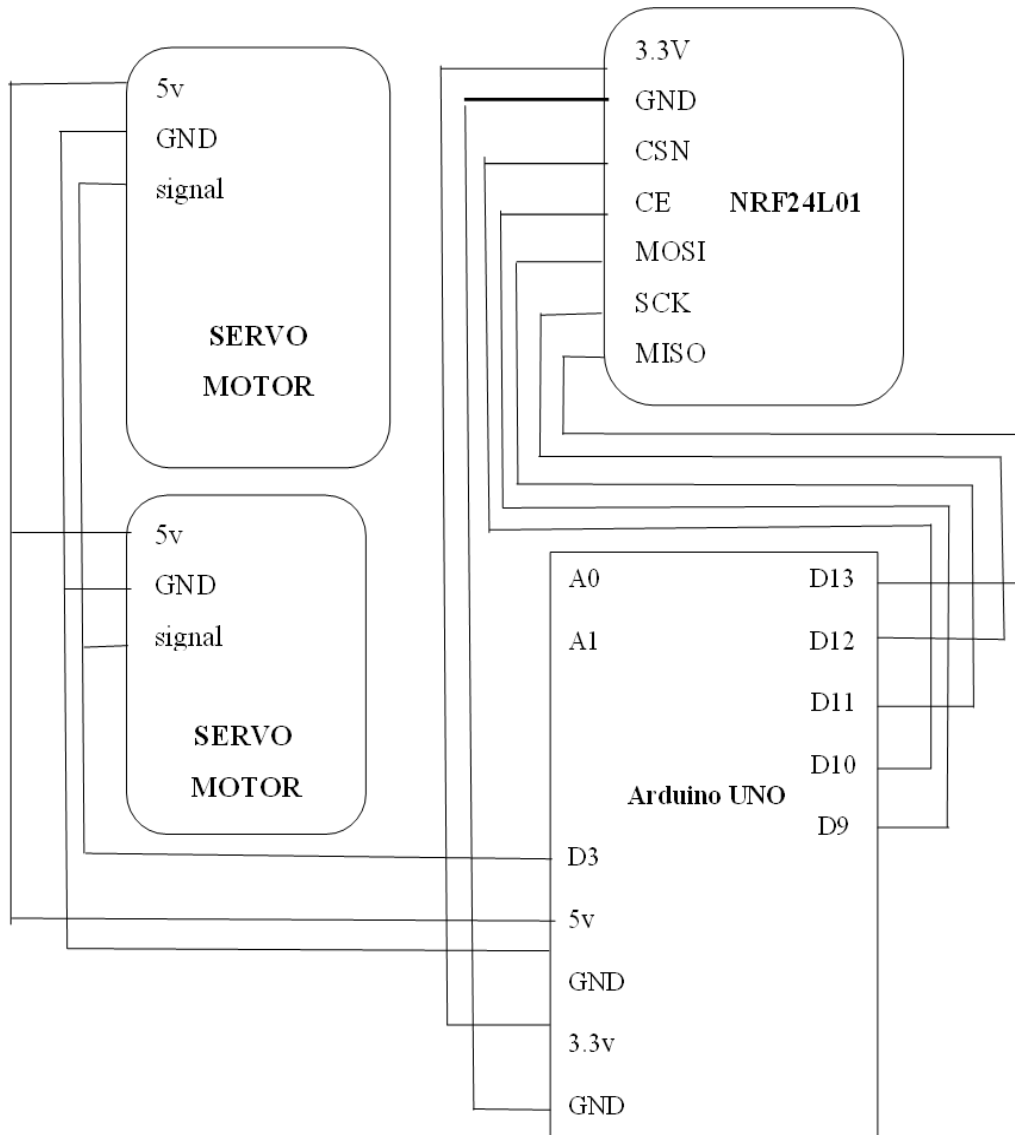

Figure.14 Receiver Circuit connections

The pin configurations for the servomotors are as follows:

**Servomotor 1:**

Signal: Pin 3

VCC: 5V

GND: GND

**Servomotor 2:**

Signal: Pin 3

VCC: 5V

GND: GND

**NRF Module 1:**

CE: Pin 9

CSN: Pin 10

MOSI: Pin 11

MISO: Pin 12

SCK: Pin 13

**NRF Module 2:**

CE: Pin 9

CSN: Pin 10

MOSI: Pin 11

MISO: Pin 12

SCK: Pin 13

**The joystick was connected to the second Arduino UNO as follows:**

X-Axis: Analog Pin A0 Y-

Axis: Analog Pin A1

Vin:5v.

## Results and Analysis

### Calculations

The torque required to lift a 2kg payload using the Tower Pro MG995 servo motor depends on the distance between the pivot point of the payload and the point where the servo motor is attached to the 3D printed arm.

The distance between the pivot point and the point of attachment is 30cm for, the torque required to lift a 2kg payload can be calculated as follows:

$$\text{Torque} = \text{Force} \times \text{Distance}$$

The force required to lift a 2kg payload is given by:

$$\text{Force} = \text{Mass} \times \text{Gravity}$$

where Mass is the mass of the payload (2kg) and Gravity is the acceleration due to gravity (9.81 m/s<sup>2</sup>). So, the force required to lift the 2kg payload is:

$$\text{Force} = 2\text{kg} \times 9.81 \text{ m/s}^2 = 19.62 \text{ N}$$

The distance between the pivot point and the point of attachment is 30cm, or 0.3m.

Therefore, the torque required to lift the payload is:

$$\text{Torque} = 19.62 \text{ N} \times 0.3\text{m} = 5.89 \text{ N-m}$$

To calculate the power required to produce this torque, we can use the formula:

$$\text{Power} = \text{Torque} \times \text{Angular Velocity}$$

The angular velocity of the MG995 servo motor at no load is approximately 0.1047 rad/s, which corresponds to a speed of 0.17 sec/60 degrees. Therefore:

$$\text{Power} = 5.89 \times 0.1047 = 0.616 \text{ W}$$

Assuming an operating voltage of 6V, the current required to produce this power is:

$$\text{Current} = \text{Power} / \text{Voltage} = 0.616 / 12 = 0.0513 \text{ A}$$

So, the Tower Pro MG995 servo motor will require a current of approximately 0.0513A to lift a 2kg payload at a pivot point of 30cm using 3D printed arms.

## Results

The Figure 15 shows wireless remote controller, which is used to wirelessly control the arm. The robotic arm is successfully interfaced with drone as is shown in figure 12. The joystick data is successfully transmitted wirelessly using the NRF24 module and received by the receiving device. The servo motor is successfully moved to the desired position based on the joystick values received, which is attached to the robotic arm.



Figure 15: Wireless remote control of arm.

Overall, the system was able to effectively transmit and receive data wirelessly, and successfully control a servo motor. The system was also able to accurately map the joystick values to the desired range and move the servo motor to the corresponding position. The robotic arm is successfully designed and built with the ability to lift up to 2kg of payload as shown in figure 16.



Figure 16: Final model of drone with robotic arm.

## **CONCLUSION**

In conclusion, this project successfully demonstrated drone with robotic arm that can be controlled wirelessly using a joystick and NRF wireless communication modules. The project's objective was to develop a robotic arm that can be used for emergency medicine transportation during floods, and the arm is capable of lifting payloads up to 2kg. To put it to effective use in a condition of emergency, it is designed a robotic arm for drone. One of the applications includes emergency transportation. Medicines are typically lightweight but are extremely valuable in terms of their impact on the health of global populations, thus making these items a potential focus for the development of drone-based delivery solutions. In future the payload capacity can be increased to 5kg and above with further more applications.

## REFERENCES

- [1]. Seo, Hoseong, Suseong Kim, and H. Jin Kim. "Aerial grasping of cylindrical object using visual servoing based on stochastic model predictive control." 2017 IEEE international conference on robotics and automation (ICRA). IEEE, 2017.
- [2]. Cvitanić, Dražen. "Drone applications in transportation." 2020 5th international conference on smart and sustainable technologies (SpliTech). IEEE, 2020.
- [3]. Nenni, Maria Elena, et al. "Development of a drone-supported emergency medical service." International Journal of Technology (IJTech) 11.4 (2020).
- [4]. Sanjana, Parvathi, and M. Prathilothamai. "Drone design for first aid kit delivery in emergency situation." 2020 6th international conference on advanced computing and communication systems (ICACCS). IEEE, 2020.
- [5]. H. Manoj T. Gadiyar, et al. "DETECTING ANOMALOUS ACTIVITIES IN SPATIO-TEMPORAL REGION" in International Journal of Engineering Applied Sciences and Technology(IJEAST), Vol. 6, Issue 1, ISSN No. 2455-2143, Pages 441-444, Published Online during May 2021.