

Semiconductor Devices: An Overview

R. Venkatesh^{1*}

Assistant Professor,
Department of Physics,
PSNA College of Engineering and Technology (Autonomous),
Dindigul 624622, Tamil Nadu, India.

Dr. S. Selvakumar²

Associate Professor,
Department of Science and Humanities,
Thamirabharani Engineering College,
Tirunelveli 627358, Tamil Nadu, India.

S. Dhasneem³

Assistant Professor,
Department of Physics,
RVS College of Engineering,
Dindigul 624005, Tamil Nadu, India.

L. Vadivel Kannan⁴

Assistant Professor,
Department of Mechanical Engineering,
PSNA College of Engineering and Technology (Autonomous),
Dindigul 624622, Tamil Nadu, India.

Corresponding author : R. Venkatesh^{1*}
Email id : lakatesh@gmail.com^{1*}

ABSTRACT

Before the advent of semiconductor devices, vacuum tubes served as the primary tools for signal enhancement, exchange, and various applications. However, despite their usefulness, vacuum tubes were bulky, required high operating voltages, and were inefficient. With the introduction of semiconductor devices such as transistors, a new era began in electronic hardware. Semiconductors are unique materials that exhibit properties that lie between those of conductors and insulators. They possess the ability to conduct electrical current to a limited extent. Among the materials commonly employed in the hardware industry, silicon stands out as the most extensively utilized semiconductor material. Initially, germanium was extensively utilized during the early stages of semiconductor development. However, due to its instability at high temperatures, silicon became the preferred choice. In this section, we will delve into the details of semiconductors, their types, and devices associated with them.

Keywords: Semiconductor, PN device, LED, Schottky diode, V-I Characteristics.

I.INTRODUCTION

Before the development of semiconductors, electronic devices relied on vacuum tubes, also known as valves. Vacuum tubes were used in a variety of applications, including radios, televisions, early computers, and electronic amplifiers. Vacuum tubes are essentially glass tubes containing metal electrodes sealed in a vacuum. They relied on the flow of electrons in a vacuum to control the flow of current and perform various functions.

However, vacuum tubes had several limitations compared to modern semiconductors:

- ❖ **Size and Fragility:** Vacuum tubes were large and bulky compared to semiconductors. They required a significant amount of space and were also quite fragile, making them less reliable and more susceptible to damage.
- ❖ **Power Consumption:** Vacuum tubes required high voltages to operate efficiently, resulting in significant power consumption. This made electronic devices using vacuum tubes less energy-efficient.
- ❖ **Heat Generation:** Vacuum tubes generated a considerable amount of heat during operation, which required additional cooling mechanisms. This further contributed to their power inefficiency and added complexity to the design of electronic devices.
- ❖ **Limited Lifespan:** Vacuum tubes had a limited lifespan, and their performance deteriorated over time. They needed frequent replacement, which increased maintenance and operational costs.

The development of semiconductors revolutionized the electronics industry by overcoming these limitations. Semiconductors are solid-state devices made from materials such as silicon and germanium. They have the ability to control the flow of electrical current by manipulating the movement of electrons.

Semiconductors brought numerous advantages, including:

- ❖ **Miniaturization:** Semiconductors enabled the miniaturization of electronic components, allowing for the development of smaller and more compact devices.
- ❖ **Efficiency:** Compared to vacuum tubes, semiconductors are more energy-efficient, requiring lower voltages to operate and consuming less power. This led to longer battery life in portable devices and reduced power consumption in general.
- ❖ **Reliability:** Semiconductors are more reliable than vacuum tubes because they have no moving parts and are less susceptible to mechanical failure. They also have a longer operational lifespan.
- ❖ **Faster Switching:** Semiconductors can switch on and off much faster than vacuum tubes, enabling higher-speed electronic circuits and faster processing.

The invention of the transistor in 1947 was a crucial milestone in semiconductor technology, as it laid the foundation for the development of integrated circuits (ICs) and microprocessors. ICs allowed multiple electronic components to be combined onto a single chip, further enhancing the capabilities and performance of electronic devices. Today, semiconductors are an integral part of nearly all modern electronic devices, from smartphones and computers to automotive systems and medical equipment. They continue to advance rapidly, with ongoing research and development pushing the boundaries of what is possible in the field of electronics.

II. BASICS OF SEMICONDUCTORS

Semiconductor materials have two distinct types of current carriers: free electrons and holes. In a natural semiconductor, the presence of ample atomic energy induces the generation of free electrons. This occurs when valence electrons from the valence band transition to the conduction band, thereby acquiring the status of free electrons. Simultaneously, this transition leaves behind vacancies in the valence band, which are referred to as holes. In an undoped, intrinsic semiconductor material, the number of holes in the valence band is equal to the number of free electrons in the conduction band. However, these materials do not conduct current well in their natural state due to the limited number of free electrons and holes.

To enhance the conductivity of a semiconductor material, it must undergo a process called doping. Doping involves introducing impurities into the semiconductor, which increases the number of charge carriers. These impurities can introduce either additional free electrons or additional holes to the intrinsic semiconductor material.

To increase the number of free electrons, pentavalent impurity particles are added during the doping process. These particles, such as arsenic, phosphorus, bismuth, or antimony, have five valence electrons. For instance, during doping, antimony atoms covalently bond with four adjacent silicon atoms. Antimony employs four of its valence electrons to establish covalent bonds with silicon atoms, resulting in the presence of an additional electron that attains free electron status. The introduction of pentavalent impurity particles into a natural semiconductor material offers a means to augment both the quantity of free electrons and the conductivity of the material. Semiconductors doped with pentavalent impurities are categorized as n-type semiconductors, owing to the prevalence of electrons as their primary charge carriers. This addition of impurities transforms an intrinsic semiconductor into an extrinsic semiconductor.

To increase the number of holes in an intrinsic semiconductor material, trivalent impurity particles are used during doping. These particles, such as boron, indium, and gallium, have three valence electrons in their outer shell. As an illustration, when a boron atom forms covalent bonds with four neighboring silicon atoms, it results in the generation of a hole. This happens due to the demand of the four silicon atoms for one electron each from the boron atom, which possesses only three valence electrons. By incorporating additional trivalent impurity particles into a natural semiconductor material, the quantity of holes can be enhanced, consequently impacting the material's conductivity. Semiconductors doped with trivalent impurities are known as p-type semiconductors, as the majority of their charge carriers are holes.

The doping process transforms an intrinsic semiconductor material into an extrinsic semiconductor, resulting in either an n-type or a p-type semiconductor material. When n-type and p-type semiconductor materials are combined,

it forms a p-n junction. This p-n junction serves as the foundation for various commonly used semiconductor devices, including diodes, transistors, and thyristors.

Semiconductors are materials with resistivity that falls between conductors and insulators. While resistivity alone does not determine whether a material is a semiconductor, there are several key properties that define semiconductors:

- ❖ Resistivity: Semiconductors have resistivity that is lower than insulators but higher than conductors. This allows them to conduct electricity under certain conditions, making them useful in electronic devices.
- ❖ Negative Temperature Coefficient: The resistance of semiconductors increases as temperature decreases and decreases as temperature increases. This negative temperature coefficient is a unique property of semiconductors.
- ❖ Doping: Adding impurities, specifically metallic impurities, to a semiconductor can alter its electrical properties. This process, called doping, allows for the control of conductivity and the creation of p-n junctions, which are fundamental to the operation of many semiconductor devices.

These properties make semiconductors versatile and crucial for various electronic applications.

Semiconductors are crucial components in modern electronic devices. They have revolutionized the industry by replacing bulky vacuum tubes, resulting in smaller and more affordable devices. This revolution has continued to advance with the development of integrated circuits. Semiconductors possess unique properties that make them ideal for electronic applications. These properties include resistivity, negative temperature coefficient, and doping. The combination of these characteristics allows semiconductors to be versatile and adaptable, making them essential for various electronic devices.

A. Conduction in Semiconductors

In electronic devices, the bonding of valence electrons in atoms plays a crucial role in the behavior of semiconductors. Unlike metals, where valence electrons are free to move, semiconductors have electrons that are strongly bonded within their outermost shells. When two adjacent atoms come close, their valence electrons combine to form electron pairs, creating covalent bonds.

Consider the example of a germanium atom with 32 electrons. Its valence electrons, which are the electrons in the outermost shell, number 4. These valence electrons tend to pair up with the valence electrons of neighboring atoms, forming electron pairs. This bonding arrangement allows for the unique properties of semiconductors and is crucial for their electronic applications (fig.1).

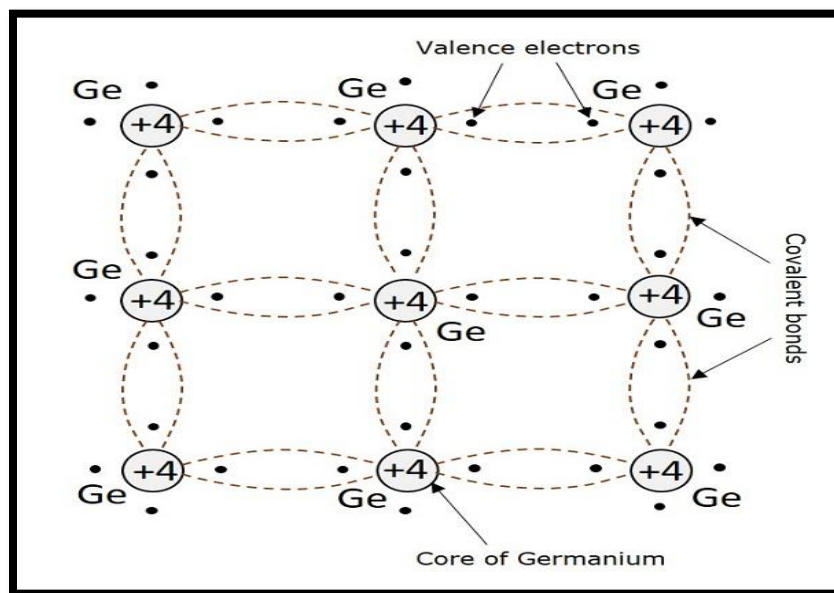

Fig. 1. Covalent Bonding of Germanium (Ge) Atoms

B. Creation of Hole

When a diamond is exposed to atomic energy, some electrons are dislodged from their positions, leading to the disruption of covalent bonds. As a result, free electrons are generated, moving in an unstructured manner without a specific trajectory. Concurrently, the displaced electrons leave behind voids, referred to as holes, in their original locations. These holes signify the absence of an electron and can be considered as unit positive charges, while the electrons themselves represent unit negative charges. When an electron is excited and moves from the valence band to the conduction band, it leaves behind an empty space called a hole in the valence band. This hole can be thought of as a positively charged particle that can move through the crystal lattice in the opposite direction to the flow of electrons. When an electric field is applied, electrons move in the direction opposite to the field, while the holes move in the same direction as the field. This movement of electrons and holes is crucial for the functioning of semiconductor devices like transistors and diodes.

C. Hole Current

In a semiconductor material, such as a silicon crystal, the atoms are arranged in a regular lattice structure. Each silicon atom contributes four valence electrons, which are shared with neighboring atoms to form covalent bonds. This results in a stable crystal structure. When an external energy source, such as heat or light, excites an electron in the valence band, it gains enough energy to break free from its covalent bond, leaving behind a "hole" in the valence band. The movement of these electrons and holes is what allows for the flow of electric current in a semiconductor device. Hence, an opening does not will regularly exist in a valuable stone. This can be better gotten a handle on by the going with figure, showing a semiconductor germanium cross segment.

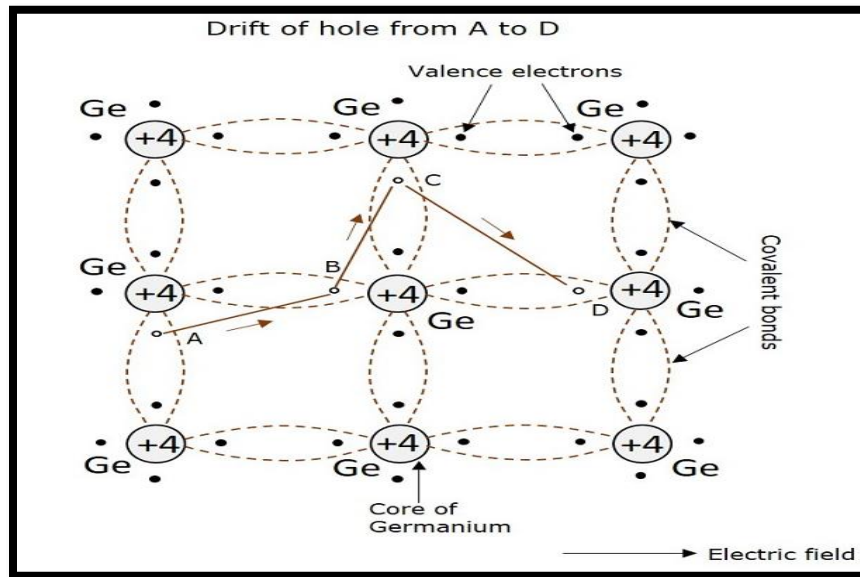

Fig. 2. Creation of Holes in Germanium (Ge) Atoms

When an electron is displaced from point A, it leaves behind a hole at its original position. To restore the covalent bond at point A, an electron from point B moves into the vacant hole (fig. 2). This process continues sequentially, forming a pathway. The generation of holes with minimal applied field is a remarkable phenomenon. However, in the presence of an electric field, the holes move in the direction of the field, resulting in hole current. It is essential to distinguish this from electron current, as it is the movement of holes that contributes to the overall flow of current. Although electrons and holes move randomly, they can meet and recombine, leading to the breaking of another covalent bond. As temperature increases, the velocities of electrons and holes rise, leading to a higher recombination rate. Consequently, the densities of electrons and holes increase, resulting in enhanced semiconductor conductivity, reduced resistivity, and a negative temperature coefficient.

III. INTRINSIC SEMICONDUCTORS

An intrinsic semiconductor refers to a semiconductor in its purest form, without any deliberate introduction of dopants. Its key characteristics include:

- ❖ The generation of electrons and holes occurs exclusively through thermal excitation.
- ❖ The number of free electrons is equal to the number of holes.
- ❖ The conductivity at room temperature is relatively low.

To increase the conductivity of an intrinsic semiconductor, it is beneficial to introduce specific impurities, a process known as doping. As a result, the doped intrinsic semiconductor is classified as an extrinsic semiconductor.

A. Doping

Doping in semiconductors is the intentional introduction of certain impurity atoms into the crystal lattice of a semiconductor material. These impurities are atoms of different elements that have either one extra electron (n-type doping) or one fewer electron (p-type doping) than the atoms of the host semiconductor material. The process of doping is crucial in semiconductor device fabrication because it allows the manipulation of the semiconductor's electrical properties. By adding controlled amounts of specific impurities, we can alter the number and type of charge carriers (electrons and holes) in the semiconductor material, thereby influencing its conductivity and other electronic characteristics.

B. Pentavalent Impurities

- ❖ The pentavalent impurities have 5 valence electrons in the outer most shell. Example: Bismuth, Antimony, Arsenic, Phosphorus
- ❖ The pentavalent atom (have 5 valence electrons) is called as a donor atom because it donates one electron to the conduction band of pure semiconductor atom.

C. Trivalent Impurities

- ❖ The trivalent impurities have 3 valence electrons in the outer most shell. Example: Gallium, Indium, Aluminum, Boron
- ❖ The trivalent (have 3 valence electrons) atom is called as an acceptor atom because it accepts one electron from the semiconductor atom.

IV. EXTRINSIC SEMICONDUCTOR

Extrinsic semiconductors are impure variations of semiconductors achieved by introducing dopants into pure semiconductors. They can be categorized into two types based on the type of dopants utilized. These types are N-type extrinsic semiconductors and P-type extrinsic semiconductors.

A. N-Type Extrinsic Semiconductor

To create an N-type extrinsic semiconductor, a small quantity of pentavalent impurity (fig.3) is added to a pure semiconductor. This impurity contains five valence electrons that become available as free electrons within the semiconductor material.

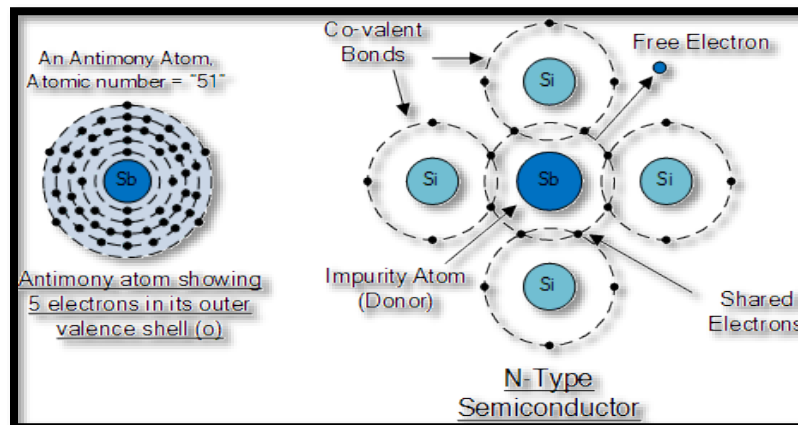

Fig.3. N – Type Extrinsic Semiconductor with Impurity Atoms

As an illustration, when an Arsenic atom is introduced into the germanium lattice, four of its valence electrons form bonds with the surrounding Ge atoms, while one electron remains unbound, acting as a free electron. This configuration is depicted in the model shown below (fig. 4).

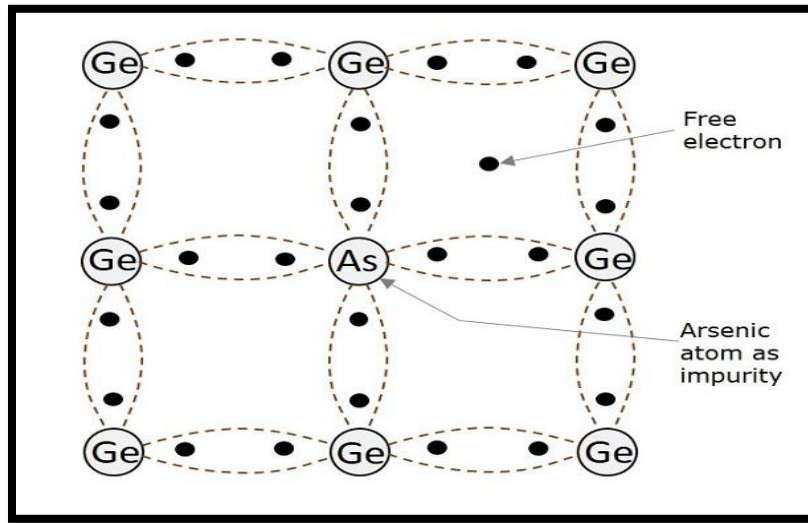

Fig.4. Covalent Bonding of N – Type Extrinsic Semiconductor

The presence of these free electrons in an N-type extrinsic semiconductor contributes to electron current, as they are the majority carriers in this type of semiconductor. The introduction of a pentavalent impurity to a pure semiconductor leads to the provision of additional electrons for conduction.

- ❖ In an N-type extrinsic semiconductor, the predominant conduction arises from the movement of electrons, which become the majority carriers, while the holes act as minority carriers.
- ❖ Due to the absence of a net increase in positive or negative charges, the presence of free electrons in the N-type semiconductor ensures electrical neutrality.
- ❖ When an electric field is applied to an N-type semiconductor containing a pentavalent impurity, the free electrons move towards the positive terminal. This kind of conductivity is referred to as negative or N-type conductivity.

B. P-Type Extrinsic Semiconductor

In the production of a P-type extrinsic semiconductor, a small quantity of trivalent impurity is incorporated into a pure semiconductor. The introduced impurity possesses three valence electrons. For instance, when a Boron atom is added to a germanium atom, three of the valence electrons from Boron form covalent bonds with the germanium atoms, establishing three covalent bonds in total. Nevertheless, one electron within the germanium remains unpaired and does not participate in bond formation. Due to the absence of an extra electron in the Boron atom to establish a full covalent bond, this unfilled space is identified as a hole. This characteristic can be observed in the illustration below (fig.5).

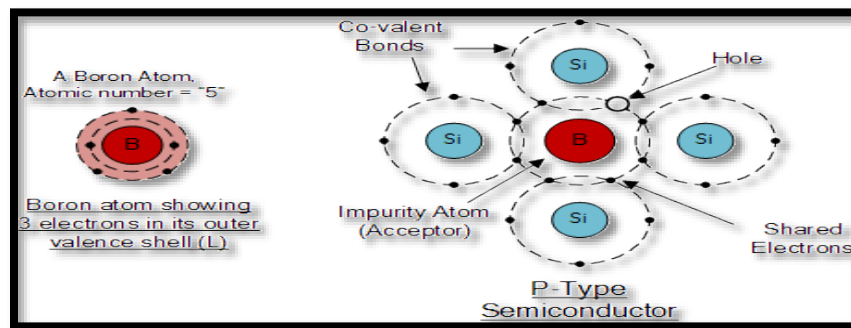

Fig.5. P – Type Extrinsic Semiconductor with Impurity Atoms

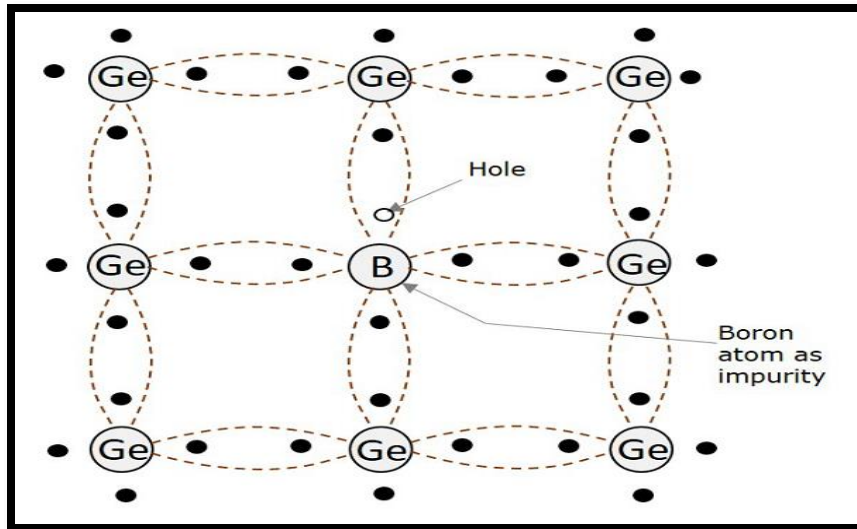

Fig.6. Covalent Bonding of P – Type Extrinsic Semiconductor

The introduction of a small quantity of boron impurity (fig.6) results in the creation of multiple holes that contribute to conduction. These holes represent hole current.

- ❖ In a P-type extrinsic semiconductor, the main conduction arises from the movement of holes, which become the majority carriers, while the electrons act as minority carriers.
- ❖ The introduced impurity, known as acceptors, generates additional holes by accepting electrons from the germanium atoms.
- ❖ The P-type semiconductor maintains electrical neutrality as the number of available holes remains equal to the number of acceptors.
- ❖ When an electric field is applied to a P-type semiconductor containing a trivalent impurity, the holes move towards the negative cathode, albeit at a slower rate compared to electrons. This phenomenon is referred to as P-type conductivity.
- ❖ In this type of P-type conductivity, the valence electrons transfer from one covalent bond to another, unlike in N-type conductivity.

Silicon (fig.7) is preferred in semiconductor technology over other materials like germanium for various reasons. Amongst these materials, silicon (Si) stands out as the most extensively utilized substance for the production of various electronic components.

The preference for silicon over germanium is based on the following factors:

- ❖ The energy band gap in silicon (Si) is 0.7 eV, while in germanium (Ge), it is 0.2 eV. The larger energy band gap in silicon makes it better suited for electronic applications.
- ❖ Silicon exhibits a lower thermal generation rate compared to germanium. This means that silicon is less prone to generating excess heat when current flows through it.
- ❖ The formation of a silicon dioxide (SiO₂) layer is relatively easier compared to germanium, making it more conducive for large-scale production and integration technologies.
- ❖ Silicon is abundantly available in nature compared to germanium, which makes it more accessible and cost-effective for semiconductor manufacturing.
- ❖ Components made of silicon (Si) have lower noise levels compared to germanium (Ge), resulting in improved overall performance and reliability.

These advantages contribute to the widespread utilization of silicon as the preferred material in semiconductor devices and electronic components.

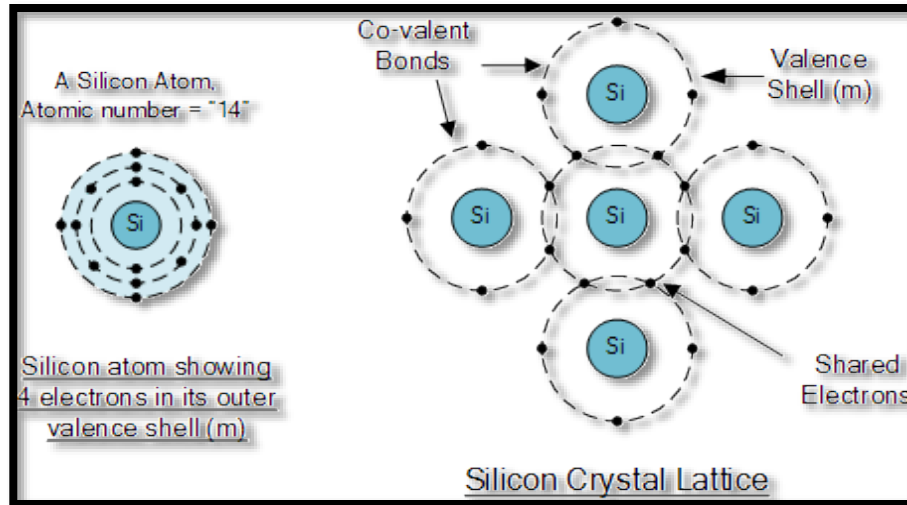

Fig.7. Covalent Bonding of Silicon (Si) Atoms

As a result, silicon is extensively employed in the production of a wide range of electronic components used for constructing diverse circuits with specific functionalities. Each component possesses unique properties and serves distinct purposes.

V. PN JUNCTION THEORY

The PN combination hypothesis demonstrates that when silicon is doped with small amounts of Antimony, it forms an N-type semiconductor material, while doping the same silicon material with limited amounts of Boron creates a P-type semiconductor material. In any case, these actually doped N-type and P-type semiconductor materials do basically no disengaged as they are electrically unbiased. Regardless, expecting it join (or wire) these two semiconductor materials together they act in an extremely astonishing manner as they merge conveying what is for the most part known as a "PN Crossing point" permitting us to zero in on the impact of PN combination hypothesis.

Whenever the P-type semiconductor and N-type semiconductor materials are first joined an extraordinarily monster thickness incline exists between the various sides of the PN combination. The result is that a part of the free electrons from the provider defilement particles begin to get across this as of late formed convergence to finish off the openings in the P-type material conveying negative particles. Anyway, because the electrons have gotten across the PN convergence from the N-type silicon to the P-type silicon, they leave insistently charged benefactor particles (ND) on the negative side and as of now the openings from the acceptor corruption get across the convergence the alternate way into the district where there are enormous amounts of free electrons. Accordingly, the charge thickness of the P-type along the convergence is stacked up with antagonistically charged acceptor particles (NA), and the charge thickness of the N-type along the crossing point becomes positive. This charge get of electrons and openings across the PN convergence is known as dispersal.

This interaction continues back and forth until the number of electrons that have crossed the junction accumulates enough electric charge to repel or prevent any further charge carriers from crossing the junction. Eventually, a state of equilibrium is reached, resulting in an electrically neutral condition and creating a "potential barrier" zone around the junction. In this zone, the donor atoms repel the holes, and the acceptor atoms repel the electrons. Since no free charge carriers can reside in a region with a potential barrier, the areas on both sides of the junction become completely depleted of any free carriers compared to the N and P-type materials farther away from the junction. This region surrounding the PN junction is now referred to as the Depletion Layer.

A. The PN junction

Due to the loss of electrons in the N-type material and the loss of holes in the P-type material, the N-type region becomes positively charged relative to the P-type region. Consequently, the presence of dopant particles on both sides of the junction creates an electric field across this region, with the N-side at a positive voltage compared to the P-side (fig.8). The challenge now is that a free charge requires additional energy to overcome the barrier present

at the depletion layer junction in order to cross it. An externally applied positive voltage between the two ends of the PN junction can supply the free electrons and holes with the necessary energy to overcome this barrier.

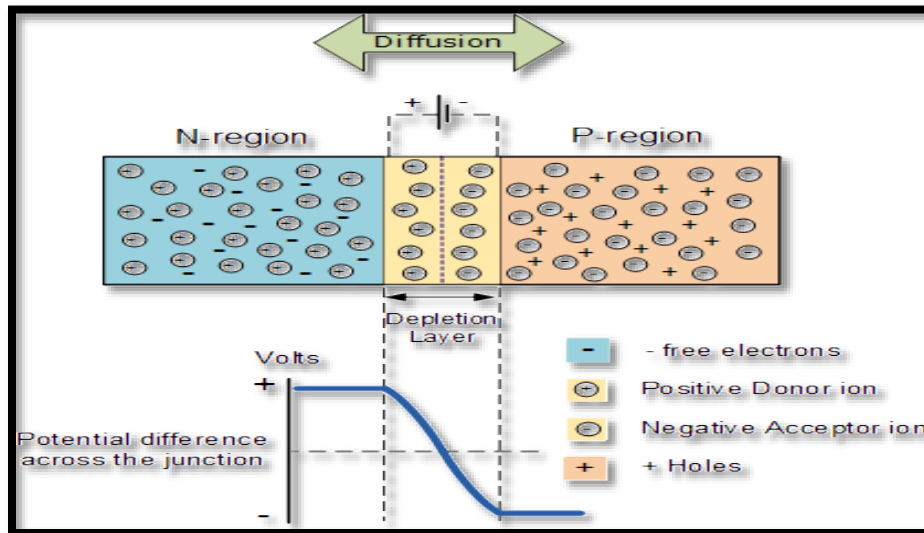

Fig. 8. PN Junction Device

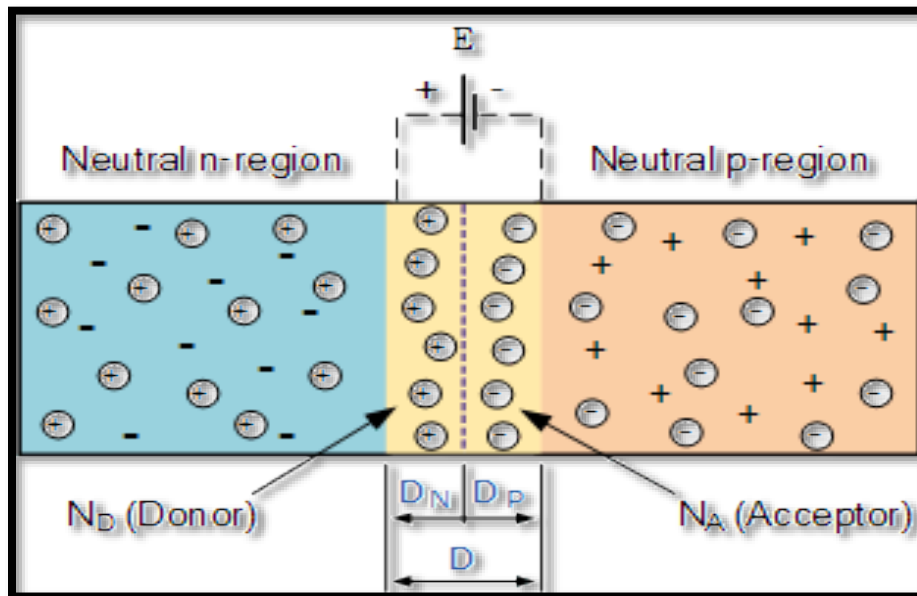

Fig. 9. Depletion Layer Distance

The outside voltage expected to beat this potential deterrent that by and by exists is a lot of wards upon the sort of semiconductor material utilized and its genuine temperature. Routinely at room temperature the voltage across the consumption layer for silicon is around 0.6 volts to 0.70 volts and for germanium is around 0.30 volts to 0.35 volts. This potential obstacle will continually exist whether the gadget isn't connected with any outer power source, as found in diodes (fig.9). The significance of this fundamental expected across the intersection point, is that it clashes with both the development of openings and electrons across the combination and is the clarification it is known as far as possible.

The PN intersection is framed inside a solitary gem of material as opposed to just consolidating or melding two separate pieces. The consequence of this cycle is that the PN intersection has correcting voltage – current (VI or V-I) attributes. Electrical contacts are joined onto either side of the semiconductor to engage an electrical relationship

with be made to an external circuit. The subsequent electronic gadget that has been made is regularly called a PN intersection Diode or essentially Signal Diode. PN intersections can be made by consolidating or diffusing contrastingly doped semiconductor materials to deliver an electronic gadget called a diode which can be utilized as the fundamental semiconductor design of rectifiers, a wide range of semiconductors, LED's, sun-based cells, and a lot more such strong state gadgets.

B. PN Junction Diode

The PN junction diode comprises a p-region and an n-region separated by a depletion region where charge is stored. In its equilibrium state, little to no external voltage is applied to the PN junction. However, when electrical connections are made to the terminals of both the N-type and P-type materials and connected to a battery source, an external source of energy exceeds the potential difference.

With the presence of this additional energy source, free electrons gain the ability to surpass the depletion region and migrate from one side to the other. A PN junction diode, one of the simplest semiconductor devices, exhibits the electrical property of allowing current flow in only one direction. However, unlike a resistor, a diode does not behave linearly with respect to the applied voltage. Instead, it has a non-linear current-voltage (I-V) relationship, and therefore, its behavior cannot be described using a simple equation like Ohm's law.

If a positive voltage (forward bias) is applied between the two terminals of the PN junction, it provides the necessary extra energy for free electrons and holes to pass through the junction as the width of the depletion layer around the PN junction decreases. On the other hand, applying a negative voltage (reverse bias) causes the free charges to be pulled away from the junction, resulting in an increased width of the depletion layer.

This behavior affects the effective resistance of the PN junction, influencing the flow of current through the diode by either allowing or impeding it. As a consequence, the depletion layer expands when a reverse voltage is applied and contracts when a forward voltage is applied. These alterations arise from the distinct electrical properties on either side of the PN junction, resulting in physical modifications. One of the consequences of these changes is evident in the static I-V (current-voltage) characteristics of PN junction diodes. This modification is demonstrated by an asymmetric current flow when the bias voltage polarity is adjusted, as illustrated below.

C. Junction Diode Symbol and Static V-I Characteristics

To utilize the PN junction (fig.10) as a functional device or as needed, it is first necessary to bias the junction. This involves applying a voltage potential across it. In the voltage diagram provided, "Bias Voltage" refers to an external voltage potential that increases the potential barrier. On the other hand, an external voltage that decreases the potential barrier is referred to as "Forward Bias."

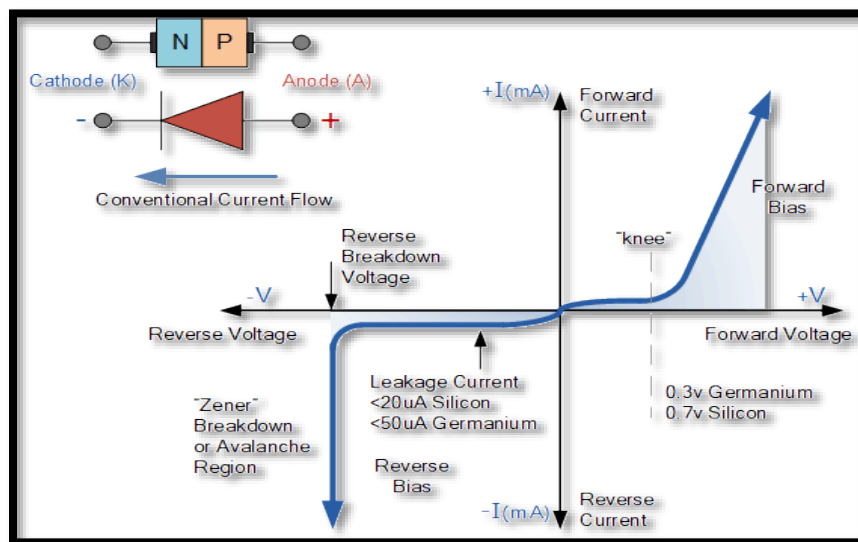

Fig.10. Junction diode and Voltage – Current (VI) characteristics

Different biasing conditions include:

- ❖ Zero Bias: In this condition, no external voltage potential is applied to the PN junction diode.
- ❖ Reverse Bias: The potential is applied in a negative direction to the P-type material and in a positive direction to the N-type material across the diode. This increases the width of the PN junction diode.
- ❖ Forward Bias: The potential is applied in a positive direction to the P-type material and in a negative direction to the N-type material across the diode. This decreases the width of the PN junction diode.

D. Zero Biased Junction Diode

When a diode is connected in a zero-bias condition, no external potential energy is applied to the PN junction. Even if the diode's terminals are shorted together, some majority carriers (holes) in the P-type material, possessing sufficient energy, are able to cross the junction against its barrier potential. This flow of carriers is known as "Forward Current." Additionally, minority carriers (electrons) generated in the N-type material successfully cross the junction in the opposite direction, which is referred to as "Reverse Current" or I_R . This exchange of electrons and holes across the PN junction is known as diffusion, as illustrated below.

However, the potential barrier restricts the diffusion of any additional majority carriers across the junction. The potential barrier allows for the drift of minority carriers (a small number of free electrons in the P-region and a few holes in the N-region) across the junction. As a result, a "Quiescent" or equilibrium state is achieved when the majority carriers are equal in number and moving in opposite directions, resulting in no net current flow within the circuit. This state indicates that the junction is in "Dynamic Equilibrium." The generation of minority carriers is continuously sustained by thermal energy. However, this equilibrium can be disturbed by raising the temperature of the PN junction (fig.11), resulting in an increased generation of minority carriers and subsequently leading to a rise in leakage current. Nevertheless, no electric current can flow as no circuit has been connected to the PN junction.

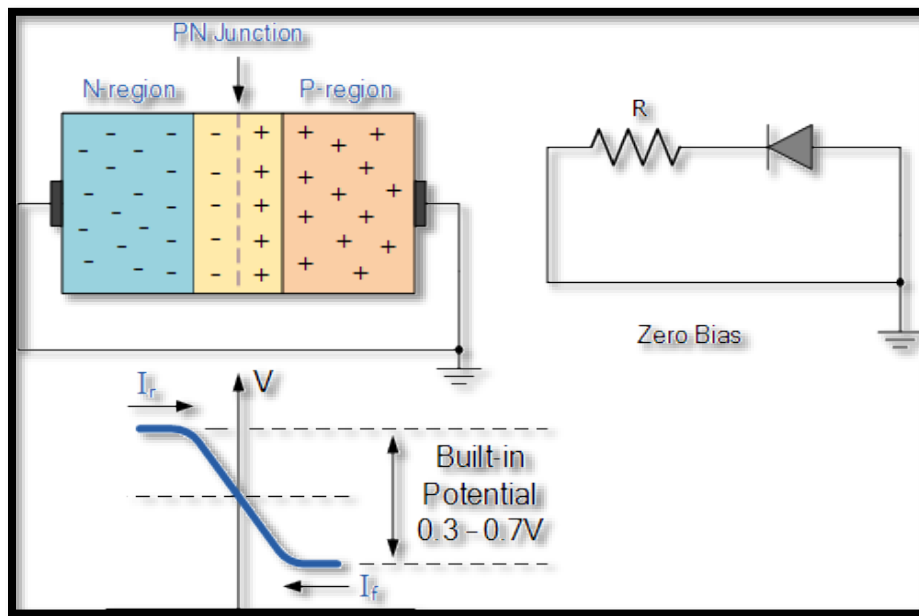

Fig.11. Zero biased PN junction diode

E. Reverse Biased PN Junction Diode

When a diode is connected in a reverse bias condition, a positive voltage is applied to the N-type material, while a negative voltage is applied to the P-type material (fig.12). The positive voltage applied to the N-type material attracts electrons towards the positive cathode and away from the junction. Similarly, the positive voltage repels the holes in the P-type material away from the junction and towards the negative anode. As a result, the depletion region

widens due to the lack of electrons and holes, creating a high impedance pathway and establishing a significant potential barrier across the junction. This barrier prevents current from flowing through the semiconductor material.

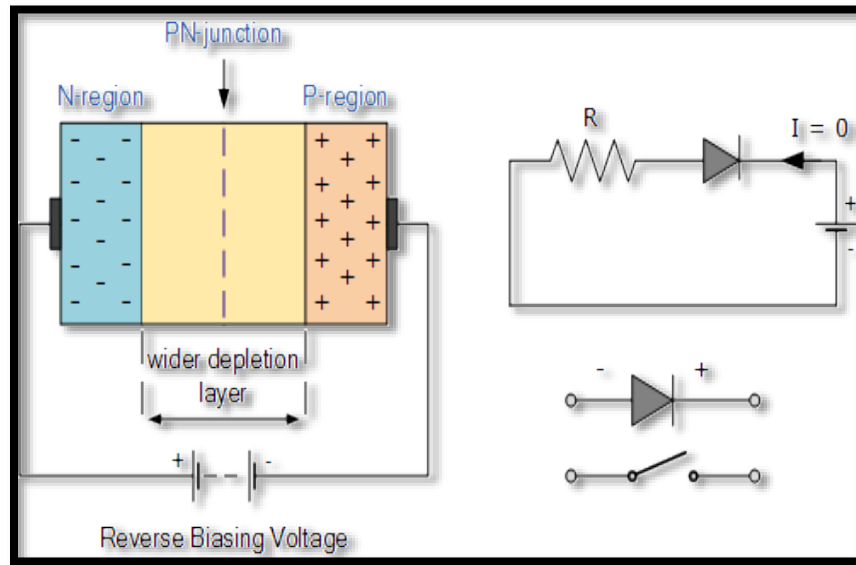

Fig.12. Increase In the Depletion Layer Due to Reverse Bias

This condition corresponds to a high resistance value across the PN junction, resulting in virtually no current flowing through the diode as the reverse bias voltage increases. However, a small reverse leakage current, typically measured in microamperes (μA), still flows through the junction. It is important to note that if the reverse bias voltage (V_r) applied to the diode is increased to a sufficiently high value, it can cause the diode's PN junction to overheat and fail due to the avalanche effect. This can result in a short circuit condition, leading to the maximum current flow through the diode. This characteristic is represented by a steep downward slope in the reverse static characteristics curve, as shown below.

F. Reverse Characteristics Curve for a Junction Diode

Occasionally, the avalanche effect has practical applications in voltage stabilizing circuits. In such circuits, a series current-limiting resistor is employed with the diode to restrict the reverse breakdown current to a predetermined maximum value. This configuration ensures a desired voltage output across the diode, as illustrated in (fig. 13).

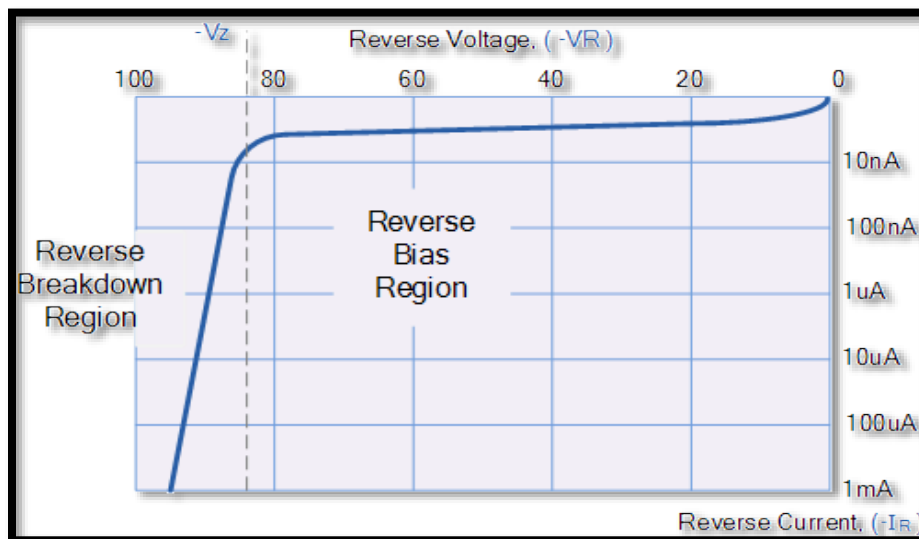

Fig. 13. Reverse Characteristics Curve for a Junction Diode

G. Forward Biased PN Junction Diode

When a diode is connected in a forward bias condition, a negative voltage is applied to the N-type material, while a positive voltage is applied to the P-type material (fig.14). If the magnitude of this external voltage surpasses the value of the potential barrier, which is approximately 0.7 volts for silicon and 0.3 volts for germanium, the resistance of the potential barrier is overcome, allowing current to flow. This phenomenon occurs because the negative voltage attracts electrons towards the junction, providing them with sufficient energy to overcome the barrier and combine with the holes that are being pushed towards the junction by the positive voltage.

Consequently, the characteristic curve of the diode initially demonstrates zero current flow up to the voltage point known as the "knee" on the static curves. Beyond this knee point, a significant increase in current flow through the diode is observed with only a slight increase in the external voltage, as depicted below.

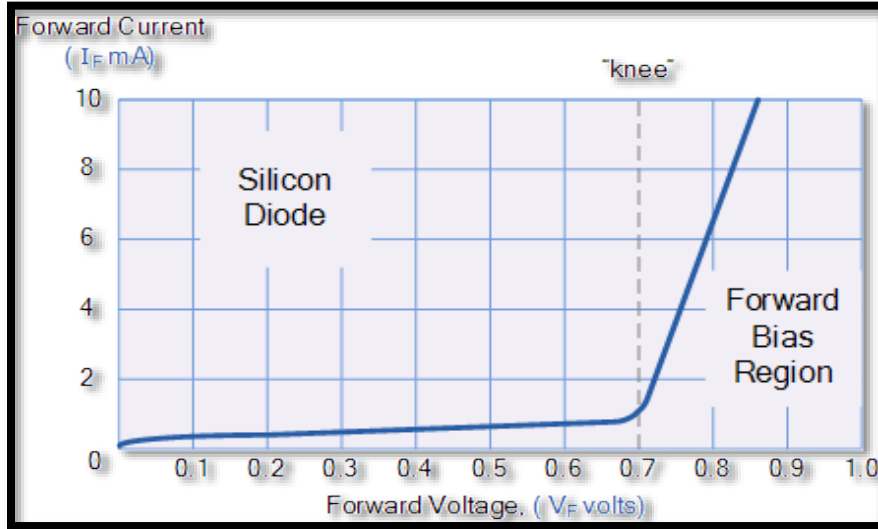

Fig.14. Forward Characteristics Curve for a Junction Diode

When a forward bias voltage (fig.15) is applied to the junction diode, it causes the depletion layer to become remarkably thin and narrow. This configuration establishes a path with low impedance across the junction, enabling the passage of high currents. The point on the static I-V characteristics curve where this abrupt surge in current takes place is commonly referred to as the point represented by "knee".

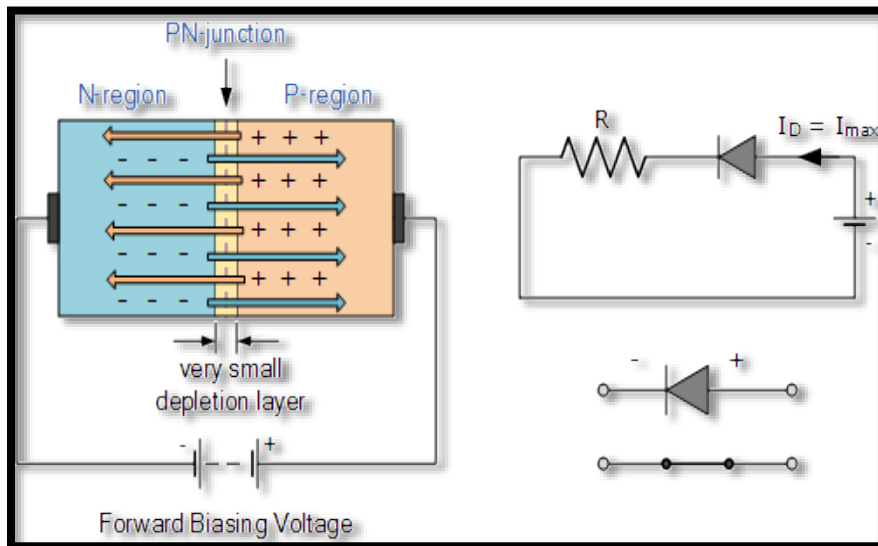

Fig. 15. Reduction of Depletion Layer due to Forward Bias

In this condition, the PN junction provides a low resistance path, allowing significantly large currents to pass through the diode with only a slight increase in forward voltage. The actual voltage drops across the junction, or diode, is maintained at a relatively constant value, approximately 0.3V for germanium and around 0.7V for silicon diodes. Since the diode can conduct "unlimited" current beyond this knee point, effectively behaving like a short circuit, resistors are utilized in series with the diode to limit its continuous flow. Exceeding the maximum forward current specification of the device causes it to dissipate more power than it was designed for, leading to rapid device failure.

VI. THE LIGHT EMITTING DIODE (LED)

The Light Emitting Diode (LED) (fig.16) is a widely recognized type of semiconductor diode. It emits a narrow range of light, such as visible light at various colored frequencies, infrared light for remote control applications, or laser-like light, when a forward current is passed through it. The LED, also known as a Light Emitting Diode, shares similar electrical characteristics with a PN junction diode. This means that an LED allows current to flow in its forward direction but blocks the flow of current in the reverse direction.

LEDs are manufactured using an extremely thin layer of moderately heavily doped semiconductor material. Depending on the type of semiconductor material used and the level of doping, when the LED is forward biased, it emits light at a specific spectral frequency. Electrons from the semiconductor's conduction band recombine with holes from the valence band, releasing energy in the form of photons. These photons generate monochromatic (single-colored) light. Due to the thin layer construction, a significant number of these photons can escape the junction and be emitted as visible light.

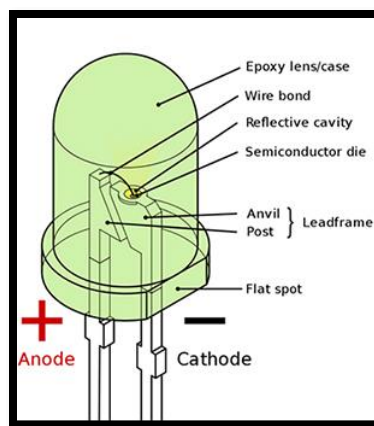

Fig. 16. LED Structure

A. LED Construction

When operated in a forward biased direction, Light Emitting Diodes (LEDs) are semiconductor devices that convert electrical energy into light energy. The construction of an LED differs significantly from that of a conventional signal diode. An LED's PN junction is encapsulated within a clear, hard plastic epoxy resin hemispherical shell or body, providing protection against vibration and shock. In particular, an LED junction does not inherently emit a significant amount of light, so the epoxy resin body is designed to reflect the photons of light generated by the junction away from the underlying substrate base to which the diode is attached. The emitted light is directed upwards through the domed top of the LED, which serves as a lens, concentrating the light. This concentration of light makes the emitted light particularly bright at the top of the LED. However, it should be noted that not all LEDs are constructed with a hemispherical-shaped epoxy shell. Some signal LEDs come in different shapes such as rectangular or round, and their physical structure may feature a flat top or be formed into a bar or arrow shape.

In most cases, LEDs have two leads protruding from the bottom of the body. Additionally, modern light emitting diodes often feature a cathode (-ve) terminal, which can be identified by a notch or flat spot on the body, or by having a shorter cathode lead compared to the longer anode (+ve) lead. In contrast to traditional incandescent lights and bulbs that generate a notable amount of heat during operation, LEDs emit a "cool" type of light. This characteristic leads to increased efficiency, as a majority of the energy generated is emitted within the visible range. As solid-state

devices, LEDs can be compact, durable, and have significantly longer lifespans compared to conventional light sources.

B. Light Emitting Diode Colors

A light emitting diode (LED) derives its color through a distinct mechanism. Unlike conventional signal diodes, which are designed for display or power rectification and often employ semiconductor materials like Germanium or Silicon, LEDs use specialized semiconductor compounds. These compounds include Gallium Arsenide (GaAs), Gallium Phosphide (GaP), Gallium Arsenide Phosphide (GaAsP), Silicon Carbide (SiC), or Gallium Indium Nitride (GaInN), combined in various proportions to achieve specific wavelength emissions. Each LED emits light within a specific region of the visible light spectrum and produces varying power levels. The choice of semiconductor material determines the wavelength of the emitted photons, thereby determining the resulting color of the light produced.

Table 1. Light Emitting Diode (LED) and its Characteristics

Type of Semiconductor Materials	Wave length Range	Color	Forward Voltage at 20 mA
Ga As	850nm - 940nm	Infra-Red	1.2 v
Ga As P	630nm - 660nm	Red	1.8 v
Ga As P	605nm - 620nm	Amber	2.0 v
Ga As P N	585nm - 595nm	Yellow	2.2 v
Al Ga P	550nm - 570nm	Green	3.5 v
Si C	430nm - 505nm	Blue	3.6 v
Ga In N	450nm	White	4.0 v

The color emitted by an LED is predominantly determined by the frequency of the generated light, which is influenced by the specific semiconductor compound used in the formation of the PN junction during manufacturing. The color of an LED is not permanently determined by its plastic body, although the body may be tinted to enhance light output and indicate color when not illuminated. LEDs are available in various colors, with common options including red, blue, yellow, and green. They are commonly used as visual indicators and in moving light displays. While blue and white LEDs have been developed, they tend to be more expensive than standard colors. This is because creating blue and white LEDs involves precise combinations of multiple semiconductor compounds and the introduction of nitrogen particles during the doping process, adding complexities to their manufacturing.

Gallium is the main P-type dopant used in the production of Light Emitting Diodes, while Arsenic serves as the primary N-type dopant. This combination results in the crystalline structure of Gallium Arsenide (GaAs) (table.1). However, Gallium Arsenide alone emits a significant amount of low-intensity infrared radiation when a forward current is applied. While this level of infrared light is suitable for TV remotes, it is not ideal for visible light emission. By incorporating phosphorus as a third dopant, the frequency of the emitted radiation is lowered to below 680nm, resulting in visible red light that can be detected by the human eye. Progress in the doping process of the PN junction has facilitated a broad spectrum of color options, encompassing visible light, infrared, and ultraviolet frequencies.

Through the combination of various semiconductor, metal, and gas compounds, a vast array of LEDs can be manufactured.

C. Types of Light Emitting Diodes (LEDs)

The color ranges of various semiconductor compounds used in LEDs are as follows:

- ❖ Gallium Arsenide (GaAs): Infrared
- ❖ Gallium Arsenide Phosphide (Ga As P): Red to infrared, orange
- ❖ Aluminum Gallium Arsenide Phosphide (Al Ga As P): Bright red, orange-red, orange, and yellow
- ❖ Gallium Phosphide (Ga P): Red, yellow, and green
- ❖ Aluminum Gallium Phosphide (Al Ga P): Green
- ❖ Gallium Nitride (Ga N): Green, emerald green
- ❖ Gallium Indium Nitride (Ga In N): Near ultraviolet, bluish-green, and blue
- ❖ Silicon Carbide (Si C): Blue as a substrate
- ❖ Zinc Selenide (Zn Se): Blue
- ❖ Aluminum Gallium Nitride (Al Ga N): Ultraviolet

Just like standard PN junction diodes, light emitting diodes (LEDs) are current-dependent devices that exhibit a forward voltage drop (V_F) influenced by the semiconductor compound and forward current. The forward operating voltage and forward current requirements differ based on the type of semiconductor material employed. Common LEDs typically have forward voltage values ranging from approximately 1.2 to 3.6 volts. The precise voltage values may vary depending on the manufacturer as well as the specific dopant materials and frequencies utilized. For example, a standard red LED has a forward voltage drop of around 1.2V, while a blue LED typically has a forward voltage drop of around 3.6V. The actual voltage drops across the LED at a given current, such as 20mA, will also depend on the specific conduction characteristics of the LED. Since an LED is a diode, its current-voltage characteristics can be represented by plotted curves for each color, as shown below.

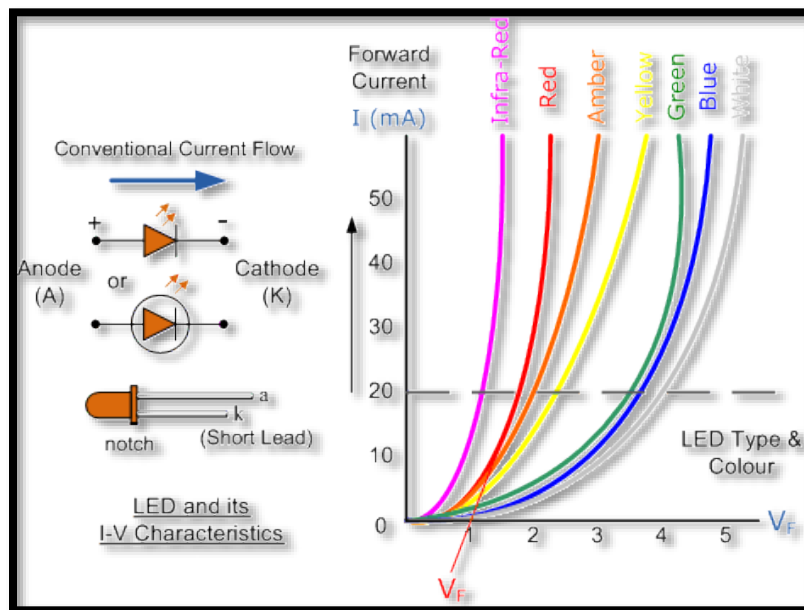

Fig.17. Light Emitting Diode (LED) V-I Characteristics

The schematic diagram and V-I (Voltage-Current) characteristics curves of a Light Emitting Diode (LED) illustrate the various available colors (fig.17). To emit light, an LED requires a current to flow through it, as its light intensity is directly proportional to the forward current passing through the light emitting diode. When connecting to a power supply in a forward biased, it is crucial to include a series resistor to limit the current. This resistor ensures that excessive current does not pass through the LED, which could lead to premature failure. It is strongly advised to never directly connect an LED to a battery or power supply without a current-limiting resistor.

The information provided in table.1 indicates that each LED color possesses a specific forward voltage drop across the PN junction. This voltage drop is determined by the semiconductor material used and is typically specified for a certain forward conduction current, commonly around 20mA. LEDs are typically operated with a less-voltage direct current supply, and a series resistor is employed to maintain the forward current at a safe value. This value can range from approximately 5 mA for a simple light indicator to 30 mA or higher for applications requiring high brightness light output.

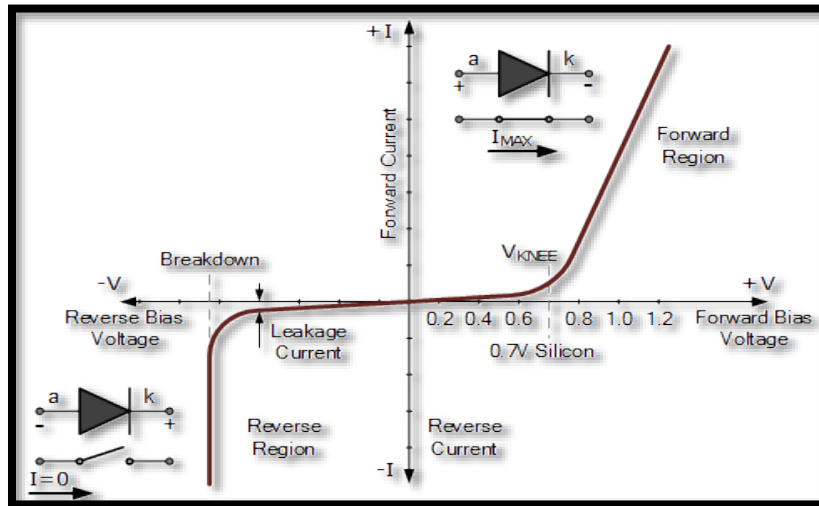

Fig. 18. PN-junction Diode V-I Characteristics

In practical silicon junction diodes, the voltage at the knee point can vary from approximately 0.6 to 0.9 volts, depending on the specific doping utilized during the manufacturing process and whether the device is a small signal diode or a larger power diode (fig.18). In contrast, the knee voltage for a standard germanium diode is typically lower, around 0.3 volts, making it more suitable for low-level signal applications. However, there exists another type of diode known as a Schottky Barrier Diode or simply a "Schottky Diode," which not only has a lower knee voltage but also exhibits a fast-switching speed. Schottky diodes find use in various applications similar to conventional PN junction diodes and offer specific advantages, particularly in digital logic, power electronics, and solar charger applications.

VII. THE SCHOTTKY DIODE

The Schottky diode, also known as the Schottky barrier diode or hot-carrier diode, is a semiconductor diode with unique characteristics. Unlike conventional PN junction diodes, which use the P-N junction as the diode's main component, the Schottky diode is based on a metal-semiconductor junction.

The Schottky diode is formed by placing a metal contact in direct contact with a semiconductor material, typically silicon. This metal-semiconductor junction creates a Schottky barrier, which allows for faster switching speeds and lower forward voltage drop compared to traditional PN junction diodes.

One of the key advantages of the Schottky diode is its low forward voltage drop, usually around 0.3 volts. This property makes it suitable for applications where minimizing power losses is essential, such as in high-frequency rectification and power switching circuits.

Schottky diodes are widely used in various electronic applications, including rectifiers, voltage clamps, and mixers in radio-frequency circuits. Their fast-switching capabilities and low voltage drop make them ideal for high-speed applications in electronic devices and power management systems.

The diagram shown in (fig. 19) presents an enhanced depiction of a Schottky diode. It comprises a lightly doped n-type silicon semiconductor that is paired with a metal electrode, creating a "metal-semiconductor junction". The width and electrical characteristics of this metal-semiconductor junction depend on the specific metal compound and semiconductor material used in its fabrication. When the diode is forward-biased, electrons flow from the n-type

material to the metal electrode, allowing current to pass through. Therefore, the conduction in a Schottky diode is primarily due to the movement of majority carriers.

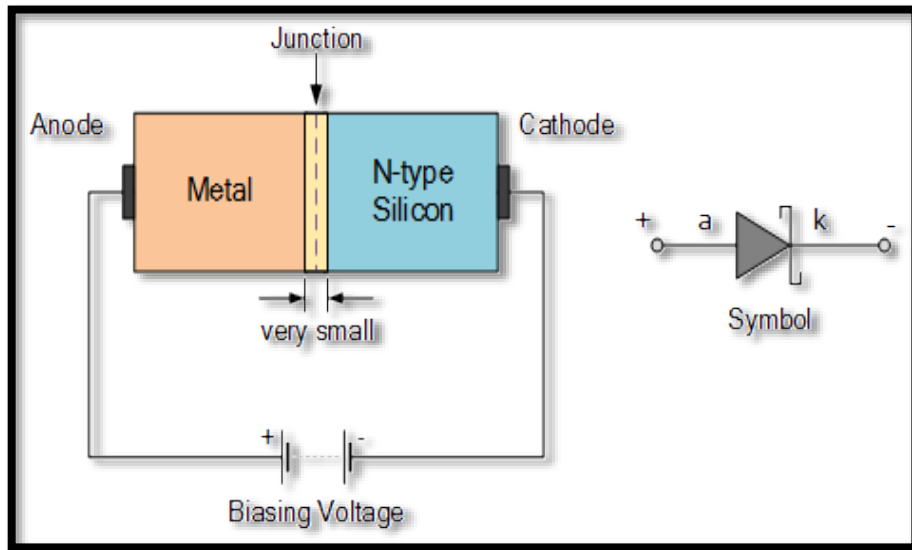

Fig. 19. Schottky Diode Symbol and Construction

When reverse-biased, the Schottky diode quickly ceases conduction since there is no p-type semiconductor material and hence no minority carriers (holes). It transitions to a high-resistance state similar to a PN junction diode. As a result, the Schottky diode exhibits a rapid response to bias changes and demonstrates characteristics akin to an ideal diode. As mentioned earlier, the knee voltage, where the Schottky diode turns "ON" and starts conducting, is significantly lower than its PN junction counterpart, as depicted in the accompanying V-I characteristics curve.

The V-I characteristics curve of a metal-semiconductor Schottky diode (fig.20) generally resembles that of a standard PN junction diode, except for the lower knee voltage at which the MS junction diode initiates conduction, typically around 0.40 volts. This lower value allows the forward current of a silicon Schottky diode to be notably higher than that of a standard PN junction diode, depending on the metal electrode utilized.

It is important to note that according to Ohm's law, power is equal to the product of voltage and current ($P = V \times I$), so a lower forward voltage drop for a given diode current, I_D , results in lower power dissipation across the junction. This lower power dissipation makes the Schottky diode a suitable choice for low-voltage and high-current applications, such as solar photovoltaic panels, where the forward voltage drop across a standard PN junction diode would lead to excessive heating. However, it should be noted that the reverse leakage current for a Schottky diode is generally higher than that of a PN junction diode.

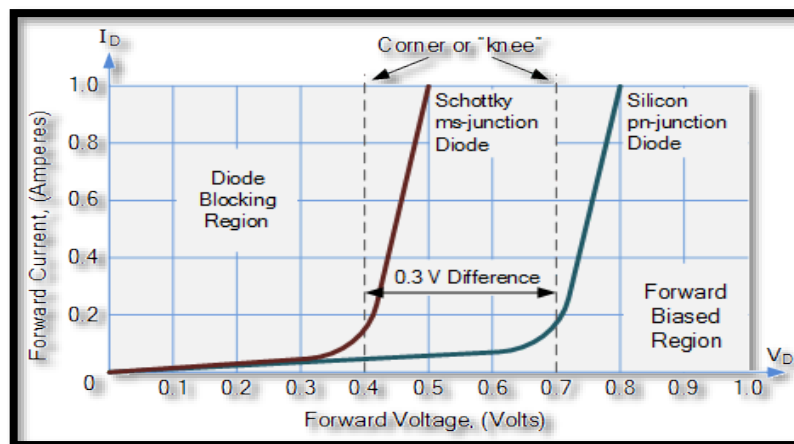

Fig. 20. Schottky Diode V-I Characteristics

If the V-I characteristics curve of a diode demonstrates a linear and non-saturating behavior, it signifies the presence of an ohmic contact. Ohmic contacts are frequently used to connect semiconductor wafers and chips to external connector pins or system components. For instance, they are employed to establish a connection between the semiconductor wafer of a typical logic gate and the pins of its plastic dual in-line package. On the other hand, Schottky diodes, which are constructed with a metal-to-semiconductor junction, tend to be slightly more expensive compared to standard PN junction silicon diodes with similar voltage and current ratings.

A. Schottky Diodes in Logic Gates

The Schottky diode is widely utilized in electronic circuits, especially in Schottky transistor-transistor logic (TTL) high-level logic gates and circuits. This is primarily because of its superior performance in terms of higher frequency response, reduced switching times, and lower power consumption. When fast switching is necessary, Schottky-based TTL becomes the preferred choice.

There are three primary series of TTL (Transistor-Transistor Logic) logic gates that incorporate Schottky diodes:

- ❖ Standard TTL (S-TTL): This series, also known as 74Sxx, utilizes Schottky diodes in its design to achieve high-speed switching and improved performance compared to earlier TTL families.
- ❖ Low-power Schottky TTL (LS-TTL): The LS-TTL series, designated as 74LSxx, combines low-power consumption with the advantages of Schottky diodes. It offers enhanced speed and reduced power dissipation compared to the standard TTL series.
- ❖ Advanced Schottky TTL (AS-TTL or ALS-TTL): The AS-TTL or ALS-TTL series, designated as 74ASxx or 74ALSxx, respectively, further improves upon the LS-TTL series by providing faster switching speeds and reduced power consumption.

These TTL logic gate series utilizing Schottky diodes are widely used in various digital and electronic applications, benefiting from the improved performance and characteristics offered by Schottky diode technology.

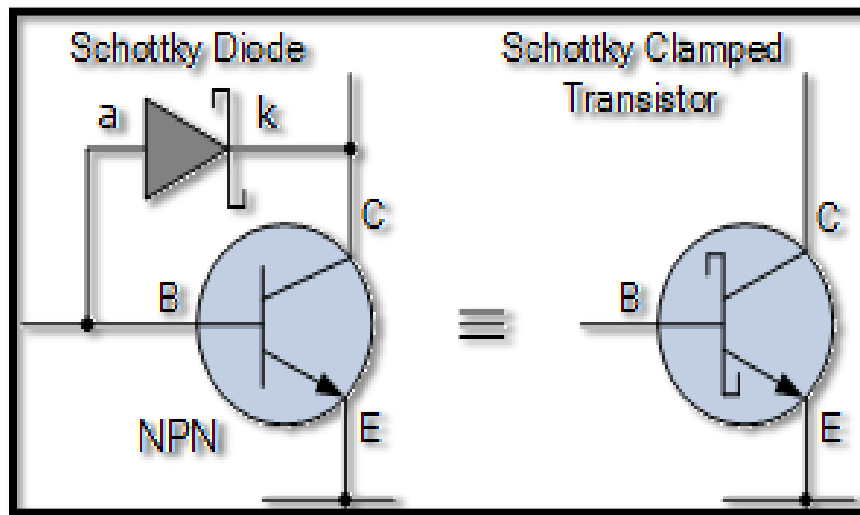

Fig. 21. Schottky Clamped Transistor

When the semiconductor operates within the active region of its characteristic curves, the base-emitter junction becomes reverse biased, allowing the semiconductor to function as a conventional NPN transistor (fig.21). A Schottky clamped transistor, also known as a Schottky transistor or Schottky-clamped logic (SCL) transistor, is a type of transistor that integrates a Schottky diode into its structure to enhance its performance and speed. The Schottky diode is connected in parallel to the base-emitter junction of the transistor, offering several advantages:

- ❖ Reduced switching time: The Schottky diode assists in minimizing the storage time and improves the speed of switching between the on and off states of the transistor.

- ❖ Lower saturation voltage: The Schottky diode helps reduce the saturation voltage of the transistor, resulting in lower power dissipation and improved overall efficiency.
- ❖ Improved high-frequency performance: The Schottky diode's fast switching characteristics enable the transistor to operate efficiently at high frequencies, making it suitable for high-speed digital and RF applications.

Schottky clamped transistors are commonly used in various applications, including digital logic circuits, switching power supplies, RF amplifiers, and high-frequency signal processing, where fast switching and low power dissipation are critical requirements.

VIII. APPLICATION OF SEMICONDUCTOR IN DAILY LIFE

- ❖ Semiconductors play a crucial role in solar technology.
- ❖ They are utilized in 3D printing machines.
- ❖ Temperature sensors used in air conditioning systems are made with semiconductor devices.
- ❖ Semiconductor control technology allows rice cookers to cook perfectly by maintaining precise temperature control.
- ❖ Semiconductors are essential for the operation of bank ATMs, trains, the internet, communications, and other aspects of the social infrastructure, including healthcare systems for the elderly, among other things.
- ❖ They are used in self-driving vehicles.
- ❖ Semiconductor devices are employed in computers, calculators, solar panels, and other electronic devices.
- ❖ CPUs, which are used in various electronic devices such as computers and mobile phones, rely on semiconductor technology. Semiconductors form the building blocks of logic gates.

IX. ADVANTAGES OF SEMICONDUCTORS

- ❖ Unlike vacuum tubes, semiconductors do not require filament heating, making them suitable for a wide range of applications.
- ❖ Semiconductor devices are solid-state devices, making them resistant to shocks and vibrations.
- ❖ Their small size makes semiconductor devices highly portable and easy to integrate into various systems.
- ❖ Semiconductors are more cost-effective compared to vacuum tubes.
- ❖ Semiconductor devices require lower input power for operation, resulting in energy efficiency.
- ❖ Semiconductor devices operate silently, producing no noise during their operation.
- ❖ Semiconductor materials have a longer lifespan and can potentially have an almost infinite lifespan.

X. INDUSTRIAL USES OF SEMICONDUCTORS

Semiconductors possess unique physical and chemical properties that make them ideal for driving technological advancements in various fields. They play a crucial role in the development of computer chips, semiconductors, LEDs, solar cells, and more. The utilization of semiconductors extends even to critical applications such as controlling the operations of spacecraft, trains, and robots, where they are integrated into CPUs and other control devices, all of which rely on the capabilities provided by semiconductor materials.

CONCLUSION

Semiconductors possess a unique combination of properties, such as controlled conduction of electric current, compact size, and low cost, making them highly versatile for various applications in different devices and systems. They play a crucial role in the development of diodes, photosensors, microcontrollers, integrated circuits, and more. Semiconductors are a class of materials that exhibit electrical conductivity between that of conductors and insulators. They can be chemically manipulated to regulate the flow and control of electric current. Intrinsic semiconductors, such as silicon, germanium, and gallium arsenide, have high chemical purity but poor conductivity. Extrinsic semiconductors, on the other hand, contain impurities that significantly enhance their conductivity through a process called doping.

Advancements in semiconductor technology have been closely linked to the rapid progress in computing. They are widely used in nearly all electronic devices, as they provide a balance between the conductive and insulating properties, allowing controlled flow of electricity. These devices are prevalent in communication systems, circuitry, and are cost-effective and compact, making them popular in both domestic and industrial applications. Semiconductor devices can be classified into two-terminal and three-terminal configurations, each with their own specific properties and applications.

REFERENCES

- [1] The Complete Guide to Semiconductor Devices [Book Review]. (1996). IEEE Circuits and Devices Magazine, 12(5), 59.
- [2] Principles of Semiconductor Devices - [Book Review]. (2006). IEEE Circuits and Devices Magazine, 22(5), 58–59.
- [3] SEMICONDUCTORS AND SEMICONDUCTOR DEVICES Semiconductors; Applications of power semiconductors; Thermionic devices; Photoelectric devices. (2013). Newness Electrical Pocket Book, 77–104.
- [4] Hsu, H. (2001). Understanding semiconductor devices [Book Review]. IEEE Circuits and Devices Magazine, 17(5), 44–44.
- [5] Kawaguchi, K. (Ed.). (2016). Chapter 11: InP-Related Nanowires for Light-Emitting Applications. Novel Compound Semiconductor Nanowires, 365–396.
- [6] Madhavan, G. (2005). Electronic and Optoelectronic Properties of Semiconductor Structures [Book Review]. IEEE Circuits and Devices Magazine, 21(1), 37–37.
- [7] Yu, P. Y., & Cardona, M. (1999). Introduction. Fundamentals of Semiconductors, 1–11.
- [8] Hamaguchi, C. (2001). Quantum Structures. Basic Semiconductor Physics, 307–399.
- [9] Appendix B: Basic semiconductor junction theory. (1990). A History of the World Semiconductor Industry, 154–157.
- [10] Semiconductor Processing. (n.d.). Physics of Semiconductor Devices, 363–408.
- [11] Metal-semiconductor Contacts. (n.d.). Physics of Semiconductor Devices, 139–151.
- [12] Feichtinger, H. (2013). Deep Centers in Semiconductors. Materials Science and Technology.
- [13] Doshchanov, K. M. (1998). Charge-transfer theory in polycrystalline semiconductors with deep impurity centers. Semiconductors, 32(6), 619–624.
- [14] Semiconductor Basics. (2016). III-V Integrated Circuit Fabrication Technology, 29–58.
- [15] Hussain, A. M. (2021). Semiconductor Basics. Introduction to Flexible Electronics, 23–36.
- [16] Balkan, N., & Erol, A. (2021). Light Emitting Diodes and Semiconductor Lasers. Semiconductors for Optoelectronics, 219–278.
- [17] Renk, K. F. (2017). Semiconductor Materials and Heterostructures. Graduate Texts in Physics, 475–483.
- [18] A Phenomenological Approach to Diode Lasers. (2012). Diode Lasers and Photonic Integrated Circuits, 45–90.
- [19] Bozhkov, V. G., & Zaitsev, S. E. (2005). A model of the intimate metal-semiconductor Schottky-barrier contact. Russian Physics Journal, 48(10), 1085–1094.