

FUTURE OF RESEARCH IN CIVIL ENGINEERING

Prof (Dr) Pradeep Kumar Majumdar

Emeritus Professor,

C. U. Shah University, India

1.0 Introduction

Democracies suffer with it's age due to confrontations and conflicts out of increasing number of claimant of competing living standards of people using restrained material infrastructures. The main reason behind it is due to population not in proportion with land availability, diversified use of natural resources by different faiths. Civil engineering being the mother branch of all branches of engineering, it has to optimize the natural resources to accommodate infrastructure to all sections of the people with affordable price against essential facilities.

TYPES OF LIVABLE SOCIETIES

1. RURAL – These are the societies with inheritance of agricultural production and agricultural land holdings, depend heavily on urban society market for earnings. Water Resources Development structures, rural housing, warehouses, agricultural marketing infrastructure, roads and cross drainage works are the major civil engineering infrastructures required to developed.

2. URBAN - Society mostly educated and skilled to sell the products with utility manufacturing. Migrants from other native places occupying baren land holding, serving the industries and government offices.

Many looks urban localities as a transformation of rural societies with education, power and money. Growth of urban population in India is compared with the world in Figure 1. It is important for infrastructure development that, how the population distributed on land in a country. In the estimates of world, 93% of the urban growth will occur in developing countries whereas Asia and Africa will see around 80% growth.

% of urban population – India Vs. World

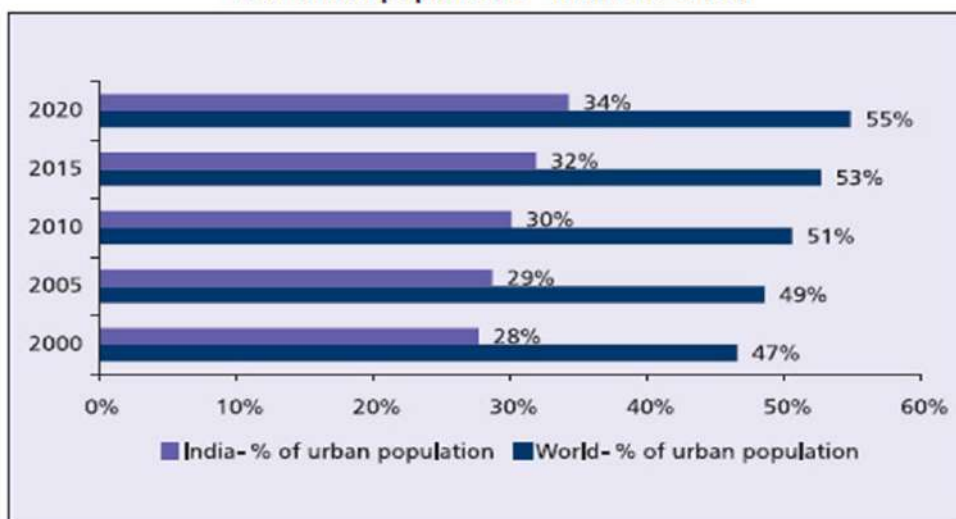

Source: United Nations

Figure1

Link:<file:///G:/March%20of%20cities/Related%20matter/Urbanization%20-%20Wikipedia,%20the%20free%20encyclopedia.htm>

Currently, urban areas roughly occupy 3% of the planet's surface, consume 75% of the global primary energy and emit 50-60% of the world's total greenhouse gases (Editors 2014; UN 2015). Urbanization is as much a social process as it is an economic and territorial process. It impacts economy, agriculture, society, environment... and everything. Urbanization has following environmental effects.

- Global warming
- Noise pollution by ever increasing vehicles on roads
- Soil moisture reduction and increase in CO₂ emissions
- Polluted air results in cardiovascular diseases
- Solid waste problem
- Pressure on civic amenities

Smart solutions for the urban development concentrate on key issues as shown in Figure 2.



Figure 2 Smart Urban Infrastructures

2.0 Trends in Civil Engineering Innovation

Innovations in civil engineering are broadly categorized under the following themes:

1. Structural Engineering and Construction material
2. Numerical Solution Techniques
3. Geotechnical Engineering

4. Transportation Engineering

Trends in scientific literature can indicate the momentum, maturity and penetration that innovative concepts and procedures achieved in the sectors of corporate and academic research by offering insight in to patent outputs and scientific articles respectively. Origin of the peer reviewed articles published from data in the field, in the journals of four specified areas, are shown in Figure 3. Europe doing better than Asia and also done better till 1975 than US and Canada. Water and energy sectors are not included in Figure 3 and will be discussed separately in the later part of the chapter.

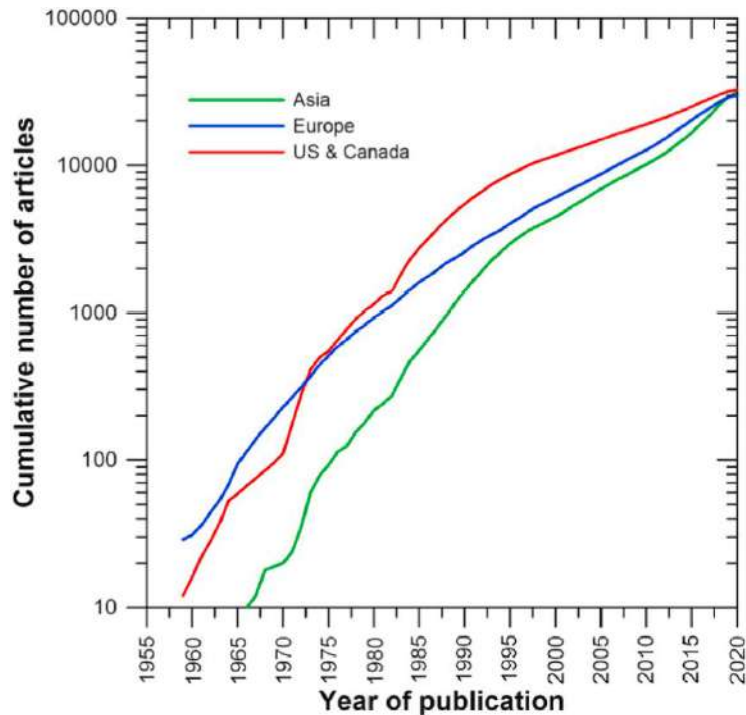

Figure 3. Innovation growth in four specialized areas of civil engineering.

Civil infrastructures use cement as major construction material, inciting CO₂ emission. These projects have tendency of getting late or cancelled due to socio-political issues concerning with environmental protection and changes in the dynamics of economic resources. Therefore, construction management using advanced optimization techniques and risk-based decision making is something that civil infrastructures have to rely upon. Basic issue remains in the persuasion of such projects with preference from the civil society, who will use it and return back the money to the investor with ample scope for repair and maintenance within the the economic age. There is definite relation between industrial CO₂ emission and socio-political and economic crisis. Purchase Price Index (PPI), which is the prices received by the cement producers for their output, can indicate the level of CO₂ emission. Figure 4(a) compares global industrial CO₂ emissions with respect to major socio-political and economic crisis and cement's PPI, respected scientific and patent output are related with cement's PPI in Figure 4(b). Data shown are the normalized value over the maximum emission value in that particular year.

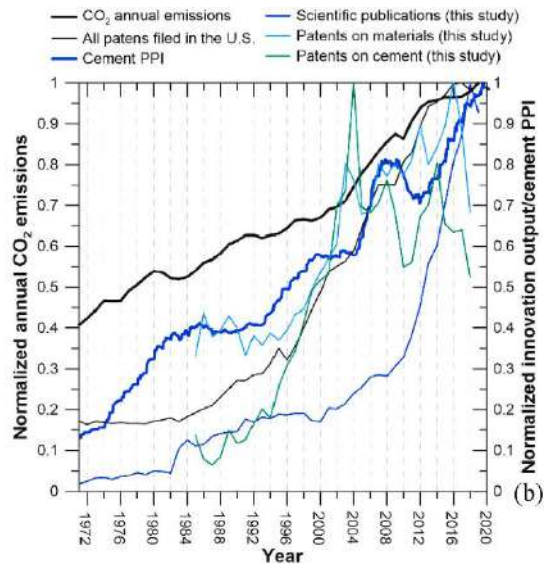
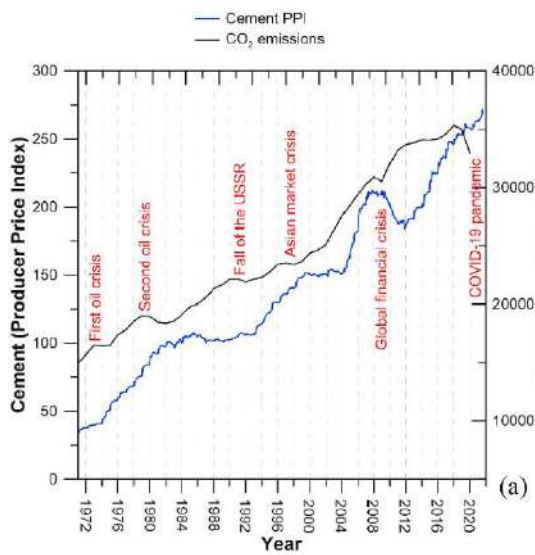

Figure 4 Global industrial CO₂ emissions

Figure 5(a) shows hardware use in the construction sector with respect to the seven, literature-based category of the construction items in each year. Figure 5(b) shows the cumulative figures since first appearance in the same categories.

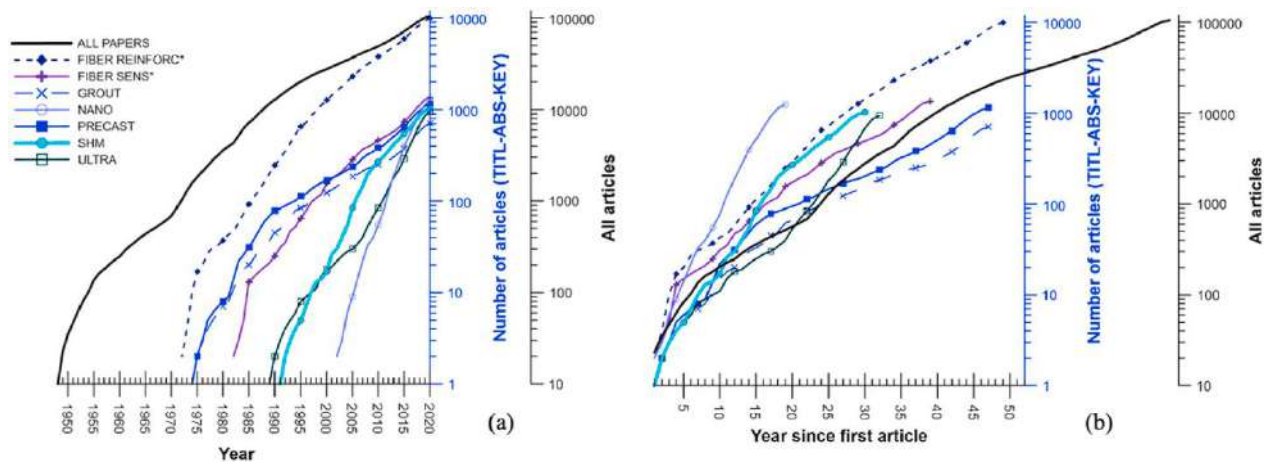

Fig. 5. Hardware innovation in various construction systems.

Figure 6(a) shows digital and numerical techniques adopted in the construction sector over the years with respect to eight types of algorithms. Same growth is shown as cumulative assessment since the first year of initiation in Figure 6(b).

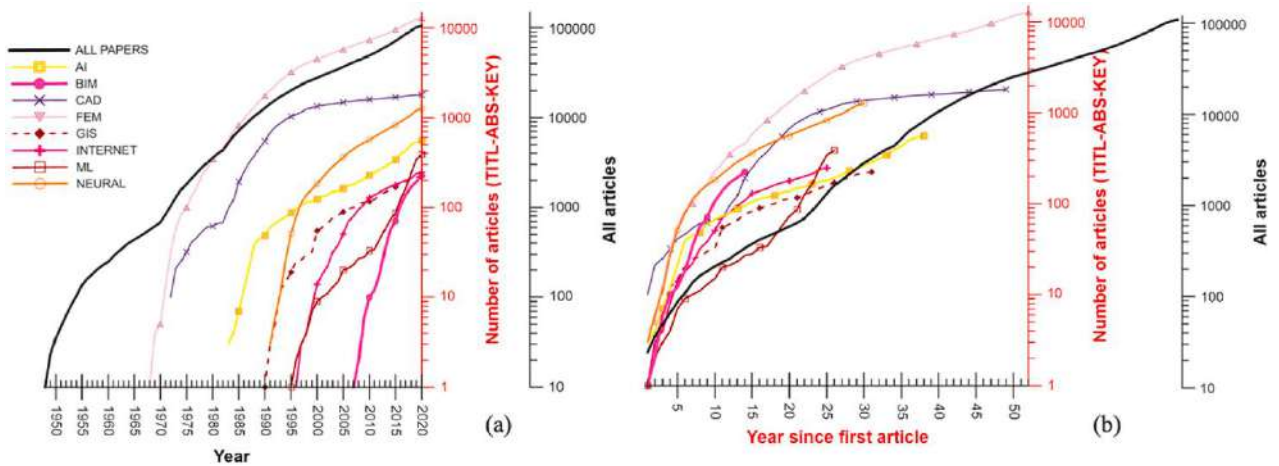

Figure 6. Growth of digital and numerical method use in construction sector.

In construction, not merely CO₂ creates the environmental degradation, but there are many other pollutants are there, which are needed to be studied in depth about life cycle and possible ways of recycling. Figure 7(a) shows the growth of environment related research in construction and Figure 7(b) shows the cumulative number of research publications since it's initiation.

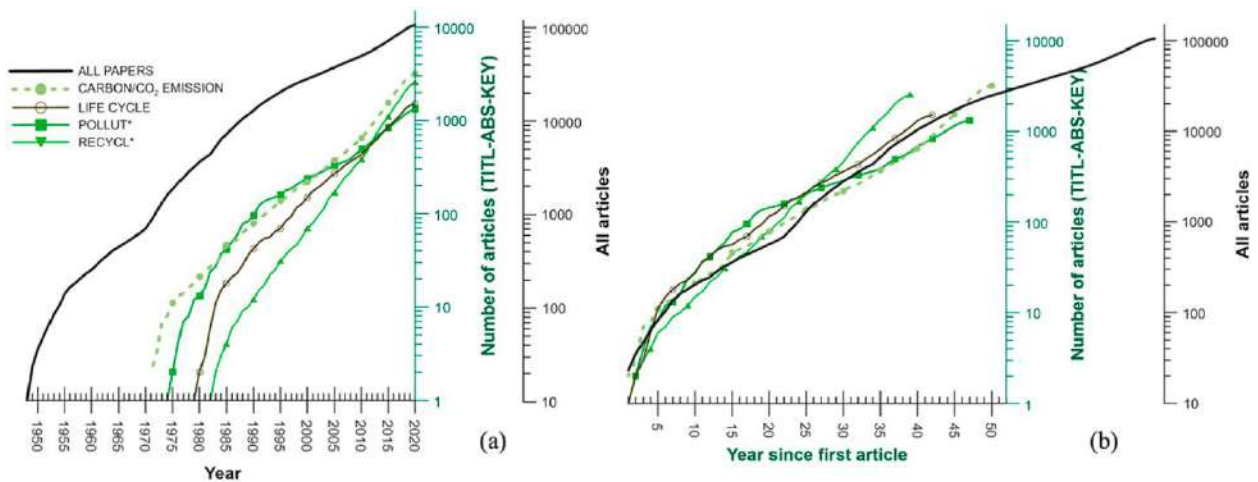

Figure 7 Environmental-related research in construction

Characterization of the research in the scales of use efficiency, novelty and innovation process is very important. Over the years research in construction targeted on seven key factors; case study, cost, efficiency, innovation, novelty, optimization and progress. Figure 8(a) shows how these factors have improved over the years, whereas 8(b) depicts the cumulative figures since the initiation of such research.

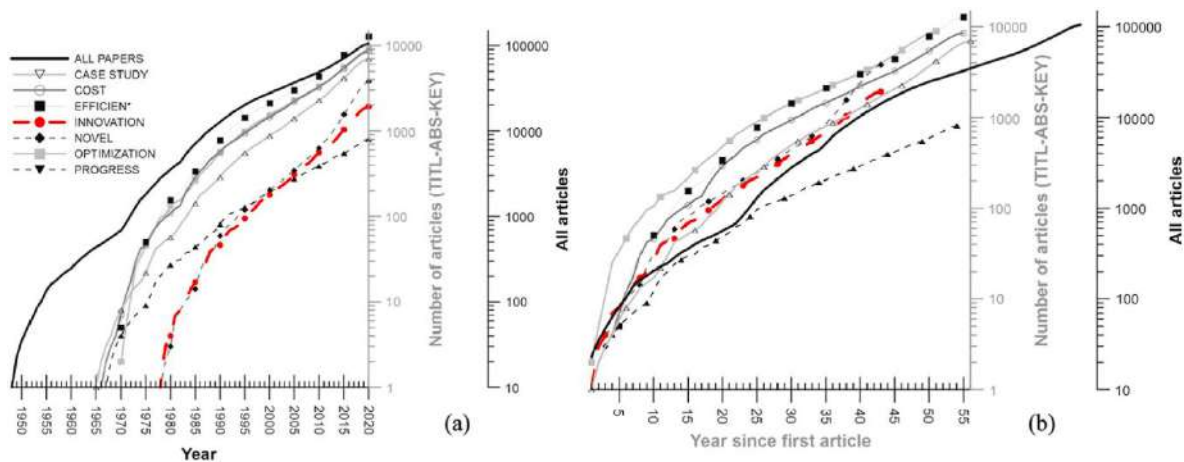

Figure 8 Growth of research factors in construction

3. Fluid and Heat interaction with Solid interfaces

Fluid flow through spillway, canal or a pipe is well established in the literatures and the same is true with heat transport through a medium, not interacting with the solid interfaces other than resisting the velocity. Molecular diffusion is understood up to Ficks law and boundary layer concepts, it's effects on the geomorphological or geological interface properties, whether porous or fractured, are still under progress. The hydraulic properties of granular materials such as sand, silt and clay mixes or that matter of fact, fracture properties of crystalline rock masses, are of great importance in various engineering applications such as earth dam protection, river and stream flow regime conditions, waster disposal, CO₂ geological storage, geothermal exploitation, spring flows and groundwater conservation. As specified by Knackstedt & Zhang (1994) and Frost & Young (2003), the permeability of granular materials is influenced by characteristic length scale of the grains, porosity, and microstructures of voids and solid phases, e.g., connectivity, tortuosity, shape/size of grains, throats, and pores. The detailed morphology of the real granular materials and fracture geometrics of consolidated formation can study the impacts of shape of granular materials and configuration of fractures on the permeability. Traditional methods of obtaining structures at nano scale are combination resin impregnation, sequential two-dimensional physical slicing, microscopic examination and various types of logs. X-ray computed tomography (CT) provides a non-destructive method to obtain the internal microstructure details. This method has been widely used to study the mechanical properties, granular and fracture flow, and heat transfer in material assemblies.

Analytically, Discrete Element Method (DEM), first proposed by Cundall (Cundall & Strack) has long history of been implemented to numerically study the behaviour granular systems such as landslides, tunnel face stability, mining industry and spring flows. The traditional spherical DEM cannot fully represent the influence of irregular particle shapes, which is commonly seen in engineering and industry. To model irregular particles using DEM, many approaches have been proposed including;

- (1) sphere clumps (Soltanbeigi et al., 2018),
- (2) equation-based approaches such as Super-quadric particles (Soltanbeigi et al., 2018), Super-ellipsoids (Wellmann et al., 2008) and Poly-Super-ellipsoids (S. Zhao & Zhao, 2019),
- (3) direct particle shape models approach including level set (Kawamoto et al., 2018), and spheropolyhedra approach (Gallindo-Toorres, 2013).

The computational Fluid Dynamics (CFD)-Discrete Element Method (DEM) method has been used for simulating particle-fluid interactions. Based on the types of CFD, there are three mainstream CFD-DEM coupling approaches, namely, the Finite Volume Method (FVM), the Smoothed Particle Hydrodynamics (SPH) and Lattice Boltzmann Method (LBM). The LBM uses distribution functions to represent the behaviour of fluid at the mesoscale without directly solving Navier-Stokes equations, which is suitable for simulating fluid flow in pores. The LBM-DEM coupling model for sphero-polyhedra particles has been developed and applied to particle-fluid interaction simulations at the particle scale (Aminpour et al., 2018).

3.1 Sphero-Polyhedra-based DEM

This DEM was originally developed based on 2D disc or 3D ball models, with particle motions obeying Newton's second law. The interactions between discrete elements are determined by the contacting laws that define the interactions between the contacting force and relative displacement in both normal and tangential directions. Traditionally, the balls and discs could be directly represented by their central point and radiuses, which makes the contact detection between particles highly efficient by comparing the distance between 2 centres and the 2 radiuses. Similarly, the motion of non-spherical DEM could be described by Newton's second law. In open-source code MechSys (Galindo-Torres, 2013), the sphero-polyhedra approach is adopted to model irregular particles with polyhedral geometries. The polyhedral surfaces are firstly eroded by a distance $175r$ (sphero-radius) and then dilatated with the same distance. After erosion-dilatation process, the generated sphero-polyhedra has a similar morphology and size as the original shape except for the edges that are rounded by a small local sphero-radius (Figure 9). The distance between the sphero-polyhedra elements could be converted to the vertex-vertex, vertex-edge, or vertex face distances. As the vertices and edges are rounded, the contact detection could be converted to sphere-sphere or sphere-face contacts, which is similar to the traditional spherical DEM and more friendly for algorithm development.

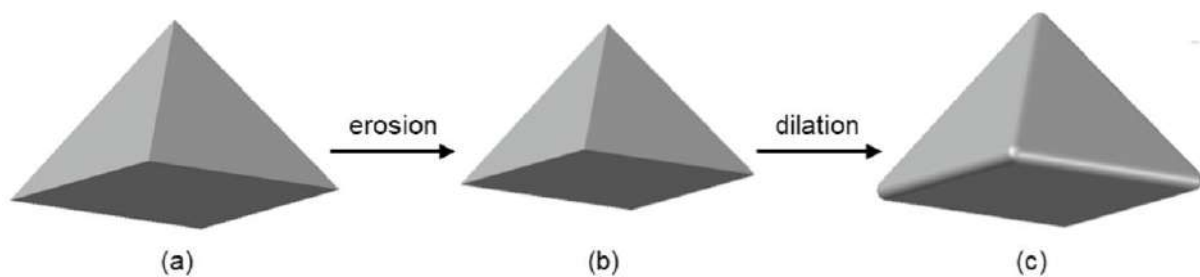

Figure 9 Particle construction in sphero-polyhedra based DEM (a) original geometry; (b) geometry after erosion; (c) geometry after dilation.

3.2 Lattice Boltzmann Method

The simulation of fluid flow at different scale is possible using this method. At the macro-scale, the Navier Stokes equations govern the behaviours of fluid flow. The equations are converted to algebraic equations throughout the discretized fluid domain and iteratively solved to numerical convergence. The accuracy and convergence of such simulations largely rely on the time steps and equality of meshes. At microscale, the fluid is considered as individual molecular particles and molecular dynamics is applied in such situation. However, the number of elements for molecular dynamics is usually extremely large to represent the macroscopic fluid behaviours. The Lattice Boltzmann Method (LBM) statically consider the distribution of fluid particles at mesoscale. The probability distribution of molecules with specific molecular motion velocity c , at temperature T , is given by the Maxwell-Boltzmann distribution function (Mohamad, 2019):

$$f(c) = 2\pi c^2 \left(\frac{m}{2\pi k_B T_K} \right)^{3/2} e^{-\frac{m^2}{2\pi k_B T_K}}$$

Where m is the mass of the molecule, $k_B = 1.380649 \times 10^{-23} \text{ m}^2 \text{ kg K}^{-1}$ is the Boltzmann constant, T_K is temperature of the gas in Kelvin.

The distribution function $f(\vec{x}, \vec{u}, t)$ gives the probability density of molecular particles at position \vec{x} , time t , with velocity \vec{u} . In LBM, the velocity \vec{u} is discretized in different directions \vec{e}_i with the respective component of the distribution function (\vec{x}, \vec{e}_i, t) . In Figure 10, the D3Q15 scheme with 15 velocity directions is shown. Zero velocity direction e_0 or zero vector at the centre of the lattice represents the stationary state or equilibrium state where there is no movement of fluid particles.

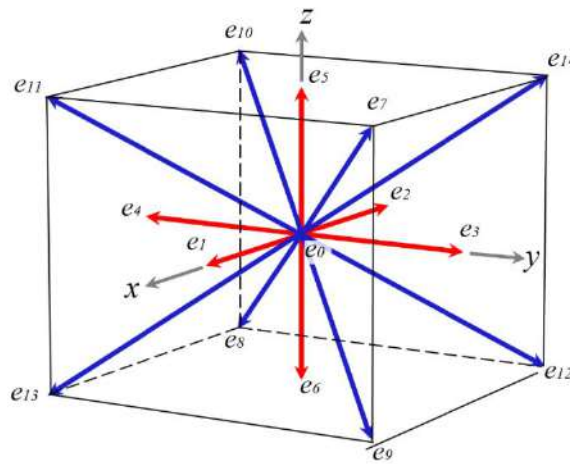

Figure 10 D3Q15 LBM cell

3.3 LBM-DEM Coupling

The coupling law between the LBM fluid and DEM particles define how the 2 phases interact with each other. With the corners of the sphero-polyhedra particles rounded, the interactions are thus converted to the interaction between LBM cells and spheres with radius r (Figure 11). On the fluid-particle boundary, LBM cells could be either fully or partially occupied by the particles. The occupied volume fraction ϵ is then simplified to the fraction of edges covered by the sphere ϵ is then calculated from the ratio between the covered edge length and the total length of the edges.

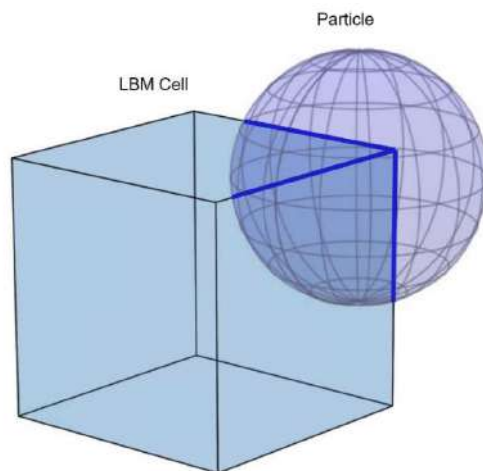

Figure 11 Schematic of Volume fraction when the DEM sphere particle interacts with LBM cell.

4. Sustainability in Water and Energy

Over the years, surface water bodies have been a first choice for water storages as compared to groundwater exploration. Although in recent times groundwater has been a major source of water for habitation due to its suitability at places, as per the drinking and agricultural water quality standards. River water disputes and quality concerns together with increase in flood frequencies due to climate change and reduction in reservoir storage capacities with age, have made the surface storages risky as compared to sustainability. Groundwater storages have an edge over the surface water storages, in terms of sustainability, in an atmosphere of high evaporation losses. Under the rising temperature due to climate change, it is going to be difficult to keep in check the evaporation losses, if continued to store water in surface water bodies only. Surface recharge options are going to be faded due to evaporation losses to surpass the infiltration and seepage rates. In such situations, recharge wells are productive. Applying artificial recharge through wells require in depth knowledge of the aquifer behaviour. These are different in alluvium and hard rock terrains. The recharge wells in alluvium cater for well functions under the radius of influence and soil water interactions, which sometimes leading to land subsidence and non-rechargeable aquifers. Whereas in hard rocks, rock mass classification and different set of abstraction and recharge wells matter. It is very important to understand and formulate the flow regimes to make the operation beneficial and even creating conducive pathways for recharge and discharge by aquifer modifications. Groundwater explorations are comparatively costly affairs, failure in terms of well yield may pose few questions and uncertainty in operation, however clubbing the renewable energy production through failed and abandoned wells can answer the critics.

Sustainability of water and energy resources under the changing climate pattern, and mainly temperature, is a challenge to the society from our very mother "nature" as we do not or at times fail to stick to the idea of use and let renew. Whereas our exploitation of non-renewable minerals and ores are polluting the environment after investing so much heavy procurement prices that one might find deaths costlier than a life. Artificial recharge of water in the subsurface domain using well recharge can save water against roaring temperatures for future use and also has potential generating geothermal energy to reduce carbon emission. Potentially other methods of artificial recharge become comparatively insignificant due to possible high rates of evaporation and evapotranspiration.

Sustainability of well recharge can be understood in the scopes of two behaviours; 1) recharge rate to remain constant for infinite time period, and 2) recharged water is to be available for consumption at particular location during stipulated time period. Else, well recharge is considered as failed and abandoned immediately or after some course of application. Main reason for such failure is termed as clogging. Initially it is considered as well loss or pressure drop, which enhances to ultimately become mechanical jamming. Exertion of more pressure at this stage means, movement of less water and movement of more soil particles in the aquifer. Continuing such activity for prolonged period of time can convert the aquifer to transform in to aquitard, aquiclude or aquifuge. Therefore, optimum recharge pressure is of paramount importance mainly in alluvium aquifers with creeping effect. Using abandoned wells in such type of formation needs extra caution. However, such wells are useful for the production of geothermal energy, a more sustainable energy alternative. Together, these two benefits, well recharge become economically sustainable solution for water management.

Consolidated and hard terrain recharge wells are more sustainable in term of structural behaviour; nevertheless, their performances depend heavily on fracture configurations existing in a rock mass. Potentiality of the hard rock aquifer does not guarantee the well yield unless the fracture orientation and aperture favour the flow towards a production well. Interesting act is that failed or abandoned wells are sometimes very useful for well recharge, as against well pumping, due to favourable flow

towards an aquifer and less clogging chances. Excessive pressure assists hydrofracturing to make the formation more conducive to well yield. In fact, hydrofracturing can be designed and controlled through geo-mechanical modelling. Well recharge in hard rocks is more beneficial, as the water recharged can be stored in the aquifer for longer time period due to its finite extension and weathered and fractured formations at shallow depth, pumping is much cheaper. Comparatively better quality of water is ensured when drafting from hard rock aquifers. These wells are also equally productive for geothermal energy, in cases, failed to produce sustainable draft.

As almost two third of our topography is underlain by hard rocks at shallow depths, exposed at places, and one third with deep thicknesses of alluviums of different ages, applications of well recharge has varied problem domains for sustainability, but can be studied under common behaviour pattern of groundwater renewability. The hydrological renewability does mean to recuperation of the depleting groundwater table with natural or artificial recharge with respect to demand at time and space. Broadly, groundwater resources are black box for the researchers, nevertheless few issues are very clear by now;

1. No artificial recharge culminates in to natural process of recharge. There is always difference between the two, even if one maintains the quality of recharge water to that of precipitation, as the dynamicity of the natural recharge is irreproducible. Therefore, all artificial recharge structures have some age.
2. With or without climate change, there is huge gap between the groundwater supply and demand from population (1.41 billion as per current UN report). No where safe yield criteria can be followed nor attempted. Planning of ground water exploitation conjunctively with other sources is found useful.
3. Groundwater at shallow depths in alluviums move faster horizontally than the deeper, due to drying up of the rivers, drains and lakes out of uses and losses. Chances of retaining recharged water for the use even after few months is bleak. Hard rock aquifers cherish more usefulness in absence of regional hydraulic gradients and comparatively lower hydraulic conductivities.
4. Wells being the structures for habitants to explore, sustainability of aquifers are replicated through performances of the production wells, considering recharge process as natural. Artificially when the same production well is considered for recharge, well hydraulics is consented as a mirror image of pumping, which is an erratic concept, as pumping has only initial phases of draft from well storage, whereas recharge is driven from well storage for the entire cycle.
5. Well loss in the pumping phase is different to the recharge phase; cone of depression causing the loss in outer face of the well during pumping, where as in recharge wells friction loss on inner face of the well matters.
6. In cases of multi-aquifer well, equivalent single aquifer concept only works when well loss is negligible.

4.0 Theory of Well Recharge

When a well is pumped, water is removed from the aquifer surrounding the well, and the water table or piezometric surface, depending on the type of aquifer, is lowered. The drawdown at a given point is the distance the water level is lowered. A drawdown curve (or cone) shows the variation of drawdown with distance from the well. In three dimensions, the drawdown curve describes a conic shape known as the cone of depression, as shown in Figure 12. Although the figure mentions streams, however it could be any water body including wells. Also, the outer limit of the cone of depression (zero drawdown) defines the area of influence of the well. This area theoretically will be a circle around an isolated pumping well and the radius is called radius of

influence. In cases of multiple wells within the radius of influence, the circular area gets distorted. What we have described above brings a disturbed hydro pressure condition with time, in the aquifer, get noticed as unsteady condition in groundwater hydrology.

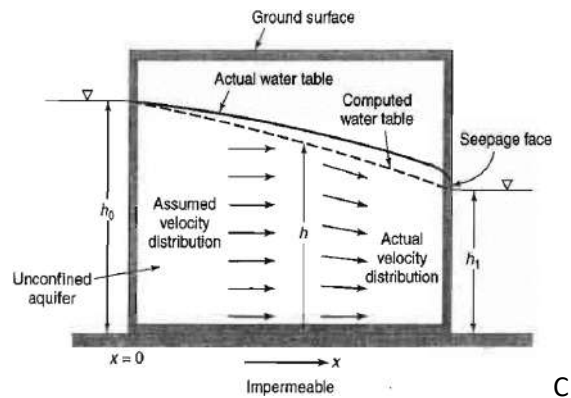

Figure 12. Steady flow in an unconfined aquifer between two water bodies with vertical boundaries.

Once the pumping activities are over, gradually the hydrostatic condition as shown in Figure 13 arises in the aquifer following the Bernoulli's theorem. The unidirectional flow shown in the figure occurs all along the circumference of the well, causing radial flow scenario as shown in Figure 14. Recharge wells are conceptualised as a mirror image of the pumping wells in producing head rises (Figure 15a) categorised as forced recharge. Confronting researches are also available where researchers have declined the theory in view of operational differences between the two, way back in the year 1962. Continuing with the mirror image concept, in fact, no investigator could estimate a unique value of the aquifer parameter during pumping and recovery phases of a pumping test in the toughest of the consolidated formations, forget the alluviums. Slug test solutions (Figure 15b) physically represent the free recharge processes; however, instantaneous pouring of water confronted the assumptions of theoretical equations at times, when carried out in larger dimensions. Therefore, exclusive solutions for recharge processes were also developed. Followings are the solutions available under these 3 categories.

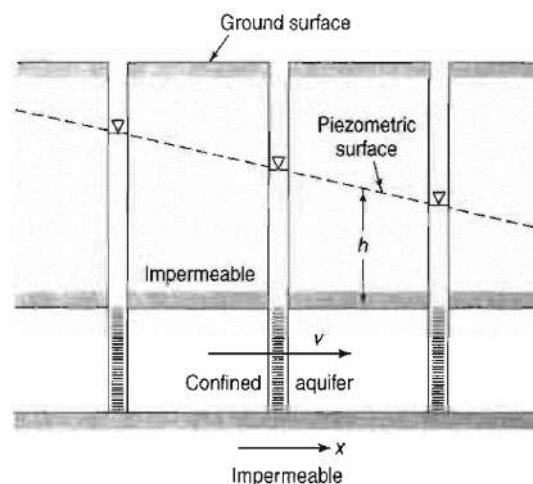

Figure 13 Steady unidirectional flow in a confined aquifer of uniform thickness.

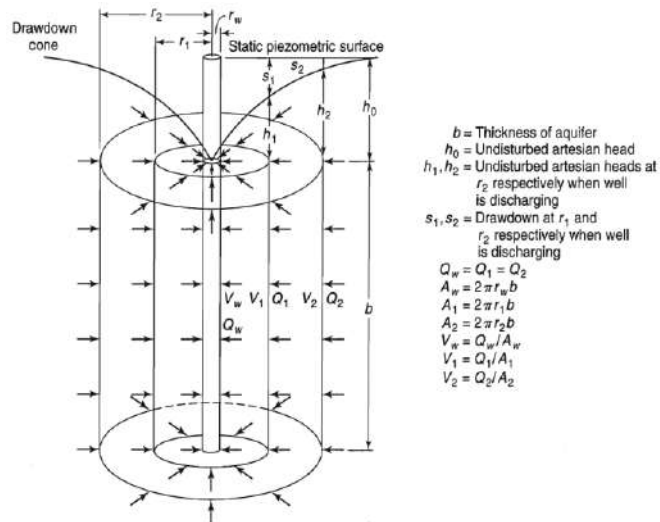

Figure 14 Radial flow from a fully penetrating well in a confined aquifer.

1. Pumping Test Solutions

THE BASIC SOLUTIONS CAN BE GROUPED AS:

■ NON-LEAKY AQUIFER SOLUTIONS

Theis (1935), Cooper and Jacob (1946)

■ SOLUTIONS FOR LARGE DIAMETER WELL

Slitcher(1906), Muskat(1937), Theis(1963), Papadopulos and Cooper(1967), Kumarswamy(1973), Patel and Mishra(1983)

■ LEAKY AQUIFER SOLUTIONS

Hantush-Jacob(1956)

Solutions For Multi-Layered Aquifers

Hunt(1985), Mass(1986), Mishra et al.(1986), Hemker and Mass(1987), Sridharan(1990), Chen and Jiao(1999)

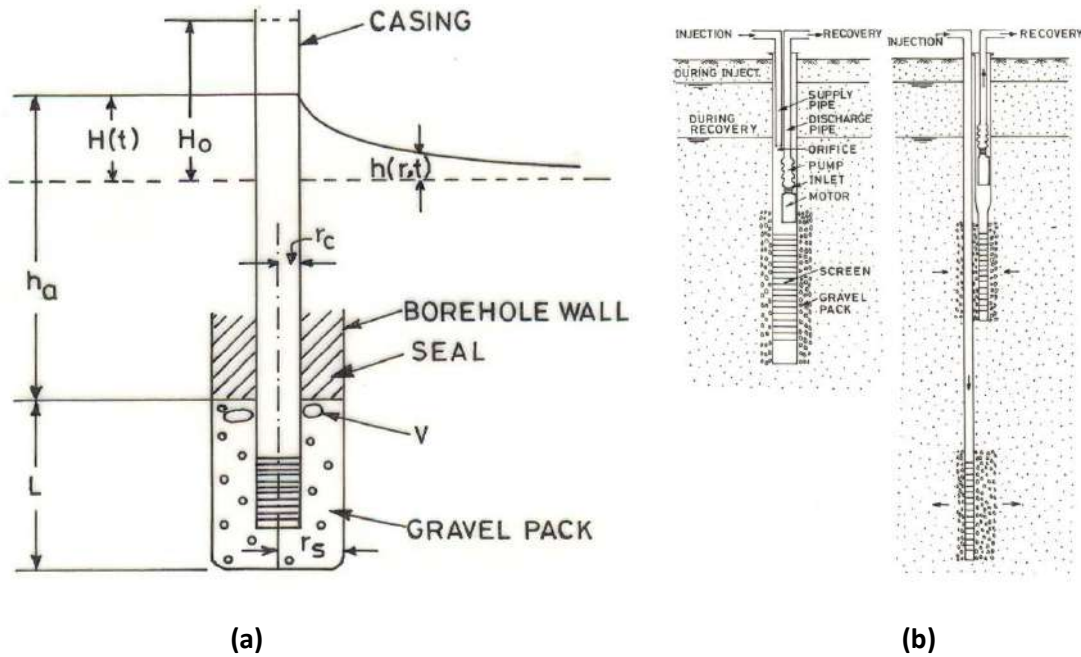

Figure 15 (a) Forced recharge and (b) Free recharge

2. Slug Test Solutions

- Cooper et al. (1967), Chirlin(1989)(Hvorslev method)
- Papadopoulos et al. (1973) for aquifers with very low storage coefficients.
- Bredhoeft& Papadopoulos (1980) and Newzit (1982) for very tight formation.
- Dax (1987) employs an empirical factor (D), equivalent to the $\ln(R_c/r_w)$ is a function of the dimensionless storage parameter (α).
- Papadopoulos et al. (1973) for aquifers with very low storage coefficients.
- Bredhoeft& Papadopoulos (1980) and Newzit (1982) for very tight formation.
- Dax (1987) employs an empirical factor (D), equivalent to the $\ln(R_c/r_w)$ is a function of the dimensionless storage parameter (α).

3. Well Recharge Solutions

Well recharge through single and multiple wells is in general addressed using numerical methods such as FDM, FEM, Analytic element method, control volume method etc., nevertheless, there are analytical solutions using Duhamel's convolution theorem, available, for free and forced recharge for various hydrogeological conditions, including multi-aquifers. More accurate than pumping test solutions, as well storages for the entire period of recharge cycle could be accounted in the unsteady estimation of recharge. Well loss is considered in those solutions as a friction loss between the recharge water column and inner well face.

5.0 Theory of Well and Aquifer Interaction during and after Recharge

Aquifer behaviours during and post recharge scenarios are varied in respect of type of formation and hydrostatic conditions. Accordingly, free recharges are executed in unconfined to semi-confined aquifers normally with dug or open wells and forced recharge is found suitable for

confined aquifers with bore wells. The concept is valid for steady state condition prior to the application, which is unfortunately very unusual to think of a domain experiencing, continuous depletion of water table even in the marked areas of artificial recharge attempts and with surface water bodies drying up. Therefore, well recharge in an unsteady water table condition should be researched in micro scale, mainly for forced recharge applications. It is fundamentally a different response that an aquifer will offer in different geological formations when well recharged. However, it can be grouped in two categories for the purpose of research; wells in alluvium and the same in hard rocks.

1. Alluvium wells

Alluvium wells are dug in the loose formations of windy and fluvial sediment deposits undergone compaction and consolidation of different ages, e. g., coastal alluviums are of recent ages and that in the river basins are of older ages. Wells in these formations require support at the well face through screens and casings. Therefore, well losses are predominant factors as shown in Figure 16. This happens with clogging of gravel pack around the well, well screens and the aquifer. Results of well loss is schematically shown in the figure as a drop of head rise, that would have otherwise occurred.

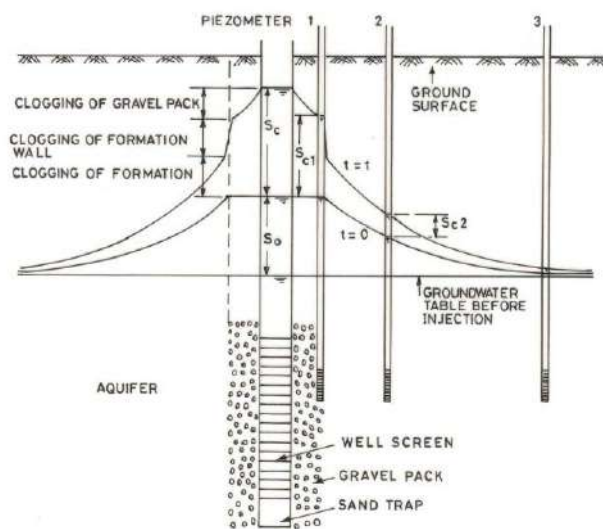

Figure 16 Well losses during well recharge

Clogging occurs due to:

- (a) Presence of air bubbles in the recharge water;
- (b) Presence of suspended matter in the recharge water;
- (c) Growth of bacteria in the gravel pack and surrounding formation;
- (d) Reaction between the recharge water and the native groundwater and aquifer material present in the formation;
- (e) Mechanical jamming

In pumping test solutions, the well loss is also handled as well skin computations. Some of the attempts are listed below

Incorporating as WELL LOSS

- Jacob (1947, 1950)
- Van Der Kamp (1976, 1984)
- Ross (1985)
- McElwee and Zenner (1993, 1998)
- Butler (1997, 2002)
- Zurbuchen et al. (2002)

Incorporating as WELL SKIN

- Ramey et al. (1975)
- Peres et al. (1989)
- Spane and Wurstner (1993)
- Ramey (1982)
- Moench and Hsieh (1985)
- Novakowski (1990)
- Liu and Butler (1995)

Numerically, adopting mirror images of these concepts to well recharge may prove to be cumbersome, as practically in recharge cases, one need to consider the head losses at the inner face of the well, not outer as the recharge operation is governed by the well storage water. More practical way of considering it could be the friction loss that occurs between the recharge water column and the inner well face, as handled in Majumdar (2005).

Interestingly poised is an issue, that pertains to what happens when the initial water table is inclined (Figure 17), which is the present water table scenario that exists everywhere. In such a situation, the pressure exerted is not uniformly distributed all along the circumference of the well, in the upstream flow side of the well face requires more pressure to inject the water and downstream side of the well injecting with added pressure. Therefore, less recharge rate would be noticed with application of the similar pressure. To maintain a recharge rate, increase in pressure would result in to damaging the well screen and subsequent movement of the soil particles with recharged water in the aquifer creating more chances of clogging of aquifer and mechanical jamming in the well face. As the aquifers are elastic in nature, how long and with how much pressure, Hook's behaviour lasts, could be a research interest for recharge in confined aquifers. In case of heavy drafts from confined aquifers, hydrostatic condition may change to unconfined state specifically in the pre monsoon and low rainfall year post monsoon periods, may reduce the retention time of the recharged water. Successive lowering and rising of water tables can cause settlements of the topography.

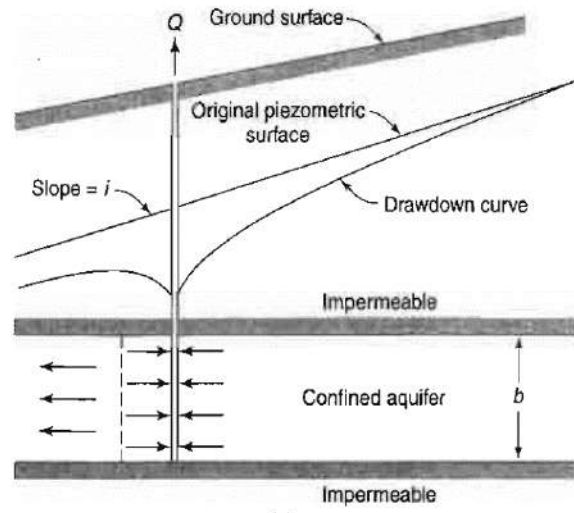

(a)

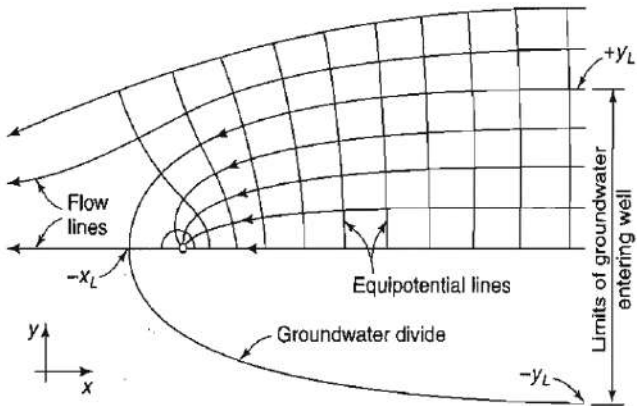

(b)

Figure 17 Flow to a well penetrating a confined aquifer having a sloping plane piezometric surface. (a) Vertical section. (b) Plan view

At the end of a pumping test, when the pump is stopped, the water levels in pumping and observation wells will begin to rise. This is referred to as the recovery of groundwater levels, while measurements of drawdown below the original static water level (prior to pumping) during the recovery period are known as residual drawdowns. A schematic diagram of change in water level with time during and after pumping is shown in Figure 18 (a). If a well is pumped for a known period of time and then shut down, the drawdown thereafter will be identically the same as if the discharge had been continued and a hypothetical recharge well with the same flow (Figure 18(b)) were superposed on the discharging well at the instant the discharge is shut down, to estimate the residual drawdown. On field, does the process in Figure (b) is possible, if so, how much extra pressure needs to be exerted to inject the water in the aquifer?

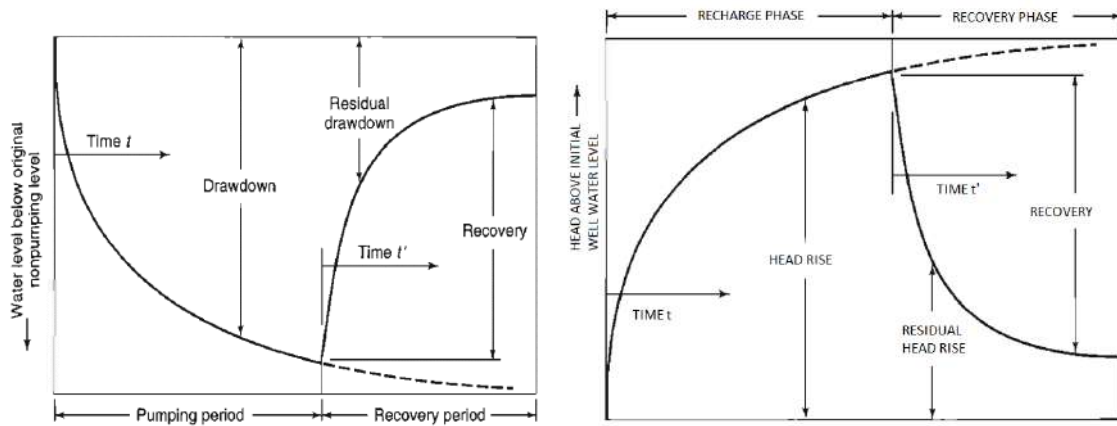

Figure 18. (a) Drawdown and recovery curves, (b) Recharge and Recovery curves.

The nonequilibrium equation applied to pumping tests in confined aquifers can also be applied to unconfined aquifers provided that the basic assumptions are satisfied. In general, if the drawdown is small in relation to the saturated thickness, good approximations are possible. Where drawdowns are significant, the assumption that water released from storage is discharged instantaneously with decline of head is frequently violated in unconfined aquifers. Pumping test data reveal that as a water table is lowered, gravity drainage of water from the unsaturated zone proceeds at a variable rate, known as delayed yield. Boulton developed special type curves for analysing pumping test data of unconfined aquifers and for taking account of delayed yield. These time-drawdown curves of delayed yield are shown in Figure 8. The interpretation of any one curve can be considered in 3-time segments. In the first segment, measured in seconds to a few minutes, water is released essentially instantaneously from storage by compaction of the aquifer and by expansion of entrapped air. This portion of the curve can be fitted by a type curve with a storage coefficient equivalent to that of a confined aquifer. The second segment displays a flattening in slope caused by gravity drainage replenishment from the pore space above the cone of depression. Finally, in the third segment an equilibrium is approached between gravity drainage and the rate of decline of the water table. This condition occurs after several minutes to several days and can be fitted by a type curve with a storage coefficient for an unconfined aquifer. Therefore, pumping test in an unconfined aquifer needs to be of longer duration to estimate accurate specific yield value. However, Figure 19 represents the present groundwater regime condition, where water tables are confronting with the text book steady state condition. For recharge scenarios, mirror image of Figure 16 is advised in text books, conceptualise it, how to get the curve for delayed flow?

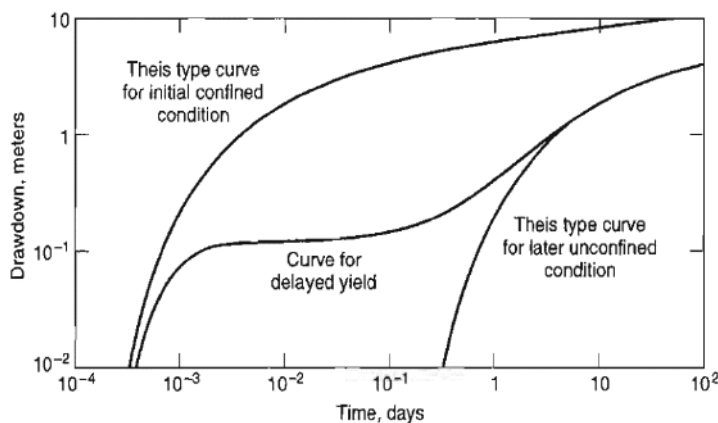

Figure 19. Type curves of drawdown versus time illustrating the effect of delayed yield for pumping tests in unconfined aquifers (after U.S. Bureau of Reclamation).

The relation between changes in groundwater levels and compression of the aquifer system is based upon the principle of effective stress. When groundwater levels are lowered, the support provided by the pore-fluid pressure is transferred to the skeleton of the aquifer system, which compresses as shown in Figure 20. When the pore-fluid pressure is increased, such as when groundwater recharges the aquifer system, support previously provided by the skeleton is transferred to the fluid and the skeleton expands. The skeleton alternately undergoes compression and expansion as the pore-fluid pressure fluctuates with aquifer-system discharge and recharge. This fully recoverable deformation occurs in all aquifer systems, commonly resulting in seasonal, reversible displacements in land surface of up to one inch or more in response to seasonal changes in pumpage.

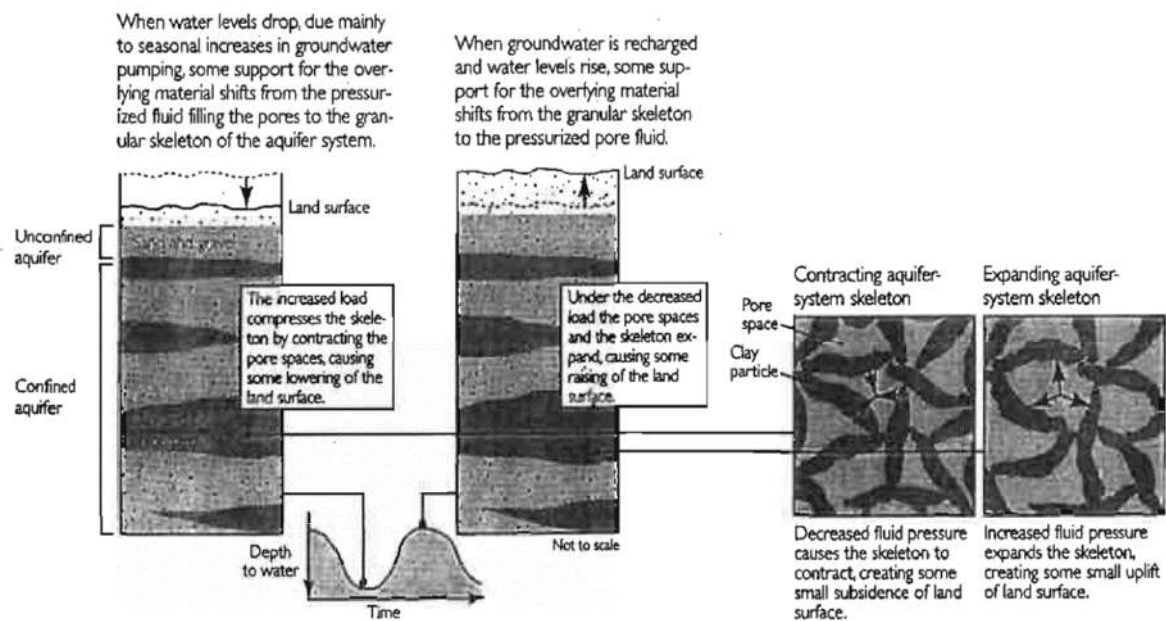

Figure 20. Relation between changes in groundwater level and compression of aquifer system (Galloway et al).

Pre-consolidation stress is the maximum level of past stressing of a skeletal element. When the load on an aquitard skeleton exceeds the pre-consolidation stress, the aquitard skeleton can undergo irreversible compaction, resulting in a permanent reduction of pore volume as the pore fluid is forced out of the aquitards into the aquifers. In confined aquifer systems subject to large-scale overdraft, the volume of water resulting from irreversible aquitard compaction is essentially equal to the volume of subsidence. This volume typically can range from 10 to 30 percent of the total volume of water pumped, representing a one-time mining of the stored groundwater and resulting in a small permanent reduction in storage capacity. The pressure diagram for a confined aquifer overlain by an unconfined aquifer is shown in Figure 21.

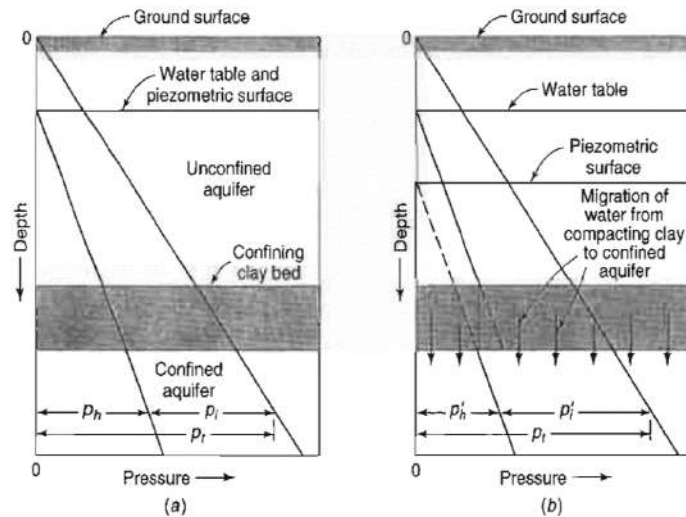

Figure 21 Graph of hydraulic and intergranular pressures as a function of depth for an unconfined aquifer overlying a confined aquifer (after Poland et al.). (a) Initial condition with water table and piezometric surface at same elevation (b) Subsequent condition with piezometric surface lowered.

2. Hard Rock wells

These wells are dug in finite aquifers, therefore no need to rely upon radius of influence, which could be at times highly mischievous as the groundwater flow occurs in a multi porous medium under semi confined state. Conceptually, water from a granular porous rock mass seeps into the fractures, which yields water to a well. Therefore, more than the drawdown curve, pipe or conduit flow is more predominant issue here. Fracture characterization is the first step, except in cases of highly weathered rock masses, available in shallow depths. Unlike the abandoned wells in the alluviums, the same could be highly useful here, as the failure of wells occur due to fracture orientation and filler material. The fracture orientation which cannot yield water to a production well, could be a preferential pathway to recharge. Elsewhere these wells are also useful for hydrofracturing of the sound rocks to yield more water in to the well. If still unproductive, the same well can be used for geothermal energy production as these rocks are highly conducive and storage efficient for temperature. Rock blasting through detonator can also create such fractures. Present state of the art technology facilitates designing the inducing pressures to create productive fracture configuration in advance.

The characteristics of natural fracture systems play a very important role in the final production of a well. The numerical models have become indispensable for the understanding of the physical processes that are present in naturally fractured reservoirs. Traditionally, dual porosity/dual permeability (DPDP) and discrete fracture models (DFM) represent fractured systems in finite element models (Lee et al., 1999). Discrete fracture models represent a fractured system more realistically and consider explicitly the effect of individual fractures on fluid flow (Karimi-Fard et al., 2003; Moinfar et al., 2011; Kim and Deo, 2000). Hence, it is common to use DFM to simulate faults and fractures of large length in highly fractured reservoirs. DPDP models may be useful to simulate sets of high-density fractures of small or medium length, where the representation of each fracture is complex and computationally expensive (Clemo, 1994). The original dual porosity concept proposed by Barenblatt et al. (1960) consists in the superposition of two porous systems with different characteristics. Warren and Root (1963) improve the dual porosity model, which assumes orthogonal fractures, parallel to the principle axes. Kazemi et al. (1976) extends the Warren and Root (1963) approach to multiphase flow. In those models, flow occurs through fractures and between matrix and fracture. Fractures isolate matrix blocks. Blaskovich et al. (1983) and Hill and Thomas (1985) introduced the dual porosity/dual

permeability (DPDP) model that permits the physical communication between blocks and incorporates the occurrence of fluid flow between them (see Figure 22).

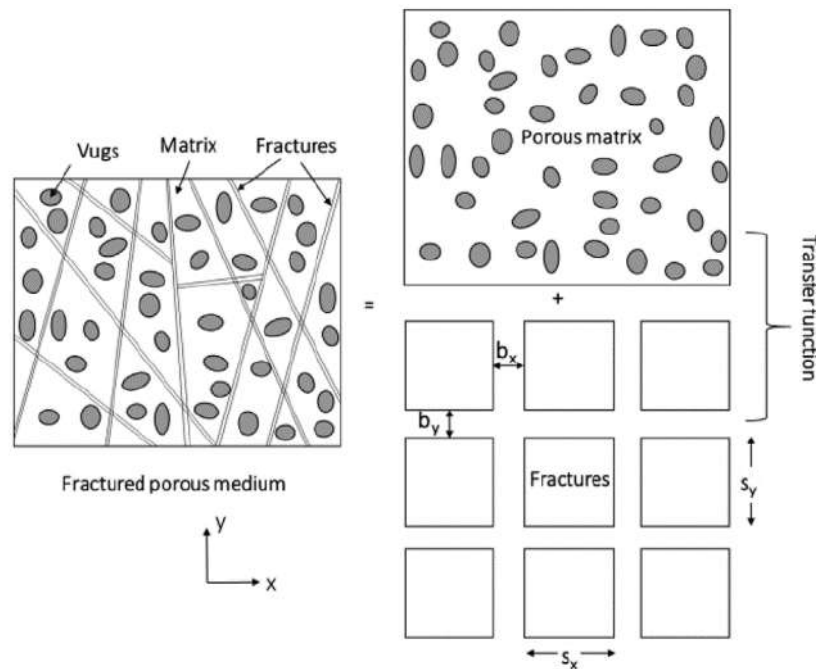

Figure 22. Idealization of naturally fractured system with dual porosity model.

Naturally fractured reservoirs are heterogeneous and present fractures of different length, aperture and conductivity (Kuchuk and Biryukov, 2014) (Figure 23). Therefore, aiming at accuracy and computational efficiency, the integration between DFM and DPDP models has been encouraged recently for flow analysis with fractures of various lengths. Gong (2007) presents a hybrid method that allows some regions of the model to be treated using the DFM and others with the multiple sub region (MSR) method using a DPDP representation. The hybrid method may be appropriate to simulate connected and disconnected fractures or enhanced accuracy in some reservoir regions. Maier et al. (2013) presents a multi-rate dual-porosity model to simulate small-length fractures and integrate it with DFM to simulate large length heterogeneities such as fractures. Li et al. (2017a,b) present a method that integrates DFM and dual-porosity, dual-permeability (DPDP) concepts to model the production process in shale oil reservoirs. The works presented above do not take into account the rock and fracture deformability, and focus on the hydraulic problem. However, there are currently some deposits whose petrophysical characteristics have altered significantly due to the changes in the stress state (Benavides Bello et al., 2005; Chen and Teufel, 1997). For that reason, the role of geomechanics is even more important in fractured media owing to the presence of fractures that are more sensitive to stress changes than the rock matrix is. The variation of stresses due to production and/or injection results in the opening, closing and reorientation of the fractures (Hermansen et al., 2000). This variation of the geo-mechanical parameters affects the permeability (magnitude and direction), one of the factors that controls the management of naturally fractured reservoirs (Bagheri and Settari, 2008). Various approaches for dual porosity/dual permeability in deformable media have been formulated (Wilson and Aifantis, 1982; Elsworth and Bai, 1992; Ghafouri and Lewis, 1996; Lemonnier and Bourbiaux, 2010; Bertrand et al., 2017). Chen and Teufel (1997) and Chen and Teufel (2000) present a comparison between some of those formulations.

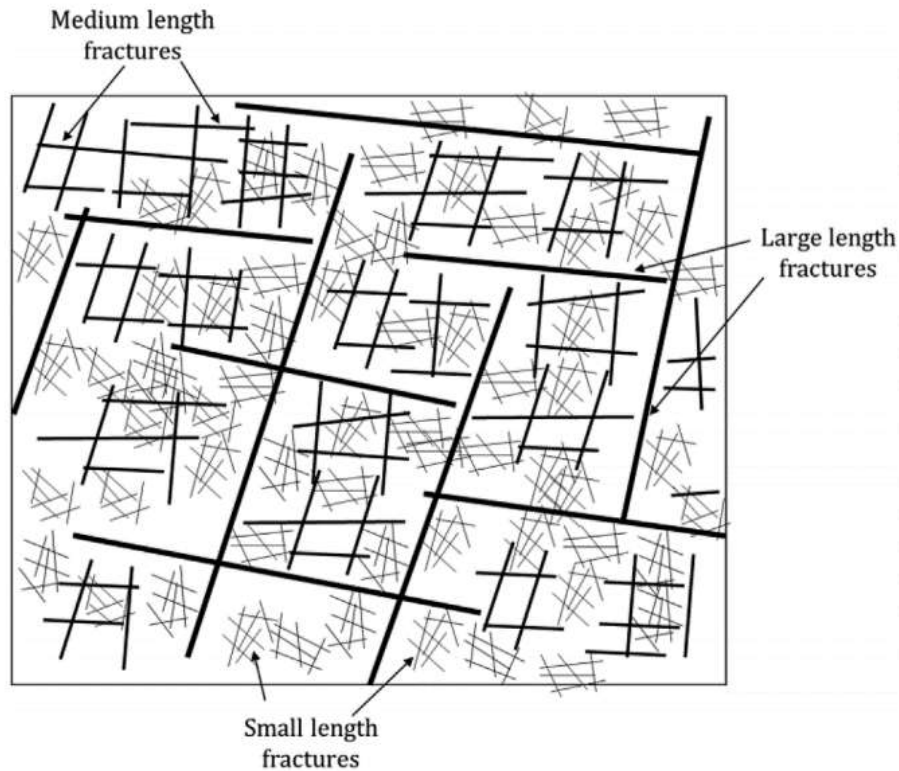

Figure 23. Schematic representation of fractured rock medium

Heterogeneity, anisotropy and interconnectivity of the fractures are the formation characteristics, influencing the flow in a major way. Heterogeneity is defined as a ratio of the average spacing of fractures in a rock mass area by Maini et al. (1972) and suggested to avoid continuum approach beyond $1/20$. Wilson and Witherspoon (1970) restricted it to $1/50$. Anisotropy is related to the fracture orientations. Rouleau and Gale (1985) defined the total interconnectivity index for a set, with an independent aperture to state that hydraulic communication within the discontinuity network diminishes with a value less than a given threshold. This is generally termed as the Percolation threshold, analyses for which are based on percolation theory (Sahimi, 1994). Martys and Garboczi (1992) reported the effects of length scales on fluid conductivity. They demonstrated that in a random pore structure, flow has affinity towards largest pore necks. Srinivasan et al. (2002) used monte carlo simulations with analytical results in different 3D objects to have fair degree of match. Lucena et al. (2003) analysed relation between anisotropy and percolation threshold in a multi-fractal medium.

When an attempt is being made to explore a well in such formations, it encounters uncertainty in the well yield due to unsuitable natural fracture patterns and artificial fracturing outcomes. However, these failed and abandoned wells are found very much useful for the recharging purposes. It is only required to comply with the yields of the production wells, by fracturing the rock mass under designed stress fields that could give rise to fractures, amicable to well yield. Well recharge in hard rocks and subsequent drafting, as and when water scarcity necessitates, is an asset to be developed as it could be done in shallow depths without much intervention to deeper aquifers or intact rock. Two third of Our country topography is overlain by hard formations, mostly face water scarcity as monsoon rain produces flash floods not having any mechanism to conserve and upsurging waterlogging conditions. Well recharge in these areas can solve twin problems of water scarcity and water logging and conserve clean water for longer periods.

3. Geo-thermal Wells

Failure of well is a very common problem, what so ever care one could indulge. Sometimes it happens at the beginning during well construction, other times after using the well for a period of time. Geothermal energy production through these abandoned wells, is a prospective idea of becoming self sufficient in renewable energy. With increasing population density of the users, water and energy management have no other choice than to generate and use these in the household level, with minimum transmission losses. Best examples are already available with the widespread use of roof top harvesting and solar panels. The energy transition has caused an increase in interest in Geothermal wells for industrial and domestic heating purposes. Geothermal energy is already being used in the agriculture industry for the heating of greenhouses.

Geothermal energy originates from the heat retained within the Earth since the original formation of the planet, from radioactive decay of minerals, and from solar energy absorbed at the surface. Most high temperature geothermal heat is harvested in regions close to tectonic plate boundaries where volcanic activity rises close to the surface of the Earth. In these areas, ground and groundwater can be found with temperatures higher than the target temperature of the application. However, even cold ground contains heat, below 6 metres (20 ft) the undisturbed ground temperature is consistently at the Mean Annual Air Temperature and it may be extracted with a ground source heat pump.

Geothermal energy comes in either *vapor-dominated* or *liquid-dominated* forms. Larderello and The Geysers are vapor-dominated. Vapor-dominated sites offer temperatures from 240 to 300 °C that produce superheated steam.

Liquid-dominated plants

Liquid-dominated reservoirs (LDRs) are more common with temperatures greater than 200 °C (392 °F) and are found near young volcanoes surrounding the Pacific Ocean and in rift zones and hot spots. *Flash plants* are the common way to generate electricity from these sources. Pumps are generally not required, powered instead when the water turns to steam. Most wells generate 2–10 MW of electricity. Steam is separated from a liquid via cyclone separators, while the liquid is returned to the reservoir for reheating/reuse. As of 2013, the largest liquid system is Cerro Prieto in Mexico, which generates 750 MW of electricity from temperatures reaching 350 °C (662 °F). The Salton Sea field in Southern California offers the potential of generating 2000 MW of electricity.

Lower-temperature LDRs (120–200 °C) require pumping. They are common in extensional terrains, where heating takes place via deep circulation along faults, such as in the Western US and Turkey. Water passes through a heat exchanger in a Rankine cycle binary plant. The water vaporizes an organic working fluid that drives a turbine. These binary plants originated in the Soviet Union in the late 1960s and predominate in new US plants. Binary plants have no emissions.

Enhanced geothermal systems

Enhanced geothermal systems (EGS) actively inject water into wells to be heated and pumped back out. The water is injected under high pressure to expand existing rock fissures to enable the water to freely flow in and out. The technique was adapted from oil and gas extraction techniques. However, the geologic formations are deeper and no toxic chemicals are used, reducing the possibility of environmental damage. Drillers can employ directional drilling to expand the size of the reservoir.

Small-scale EGS have been installed in the Rhine Graben at Soultz-sous-Forêts in France and at Landau and in Germany.