

# Wind Energy Conversion System: Theoretical Study and Concept

Dr. Vikas Kumar Sharma  
Associate Professor, Electrical Engineering  
Department  
Poornima College of Engineering  
Jaipur, India  
vk.sharma@poornima.org

Vineet Sharma  
Assistant Professor, Electrical Engineering  
Department  
Poornima College of Engineering  
Jaipur, India  
vineet.sharma@poornima.org

## ABSTRACT

Wind power production has been under the main focus for the past decade in power production and tremendous amount of research work is going on renewable energy, specifically on wind power extraction. Wind power provides an ecofriendly power generation and helps to meet the national energy demand when there is a diminishing trend in terms of non-renewable resources. This chapter presents a brief review of characteristics of wind and main components of modern WECS. Wind distribution function to determine the wind speed and hence predict certain quantities of WECS e.g. generated power, is described and wind power controlling methods are also presented. Description of most popular configurations of modern WECS,

**Keywords**— Wind Energy, Wind Turbine, Wind Generator, WECS

## I. INTRODUCTION

Electrical power has an essential role of our society and its utilization is expended worldwide to better living standard. The modern community working is dependent more on the reachability to electrical power. Energy has become most significant element in today's world as it supplies most of the human needs. Over millennia, energy is being harnessed using various fuels like coal, oil, gas etc. The rapid socioeconomic transformation brought by industrialization has drastically increased the production of energy [1]. However, this has led to the depletion of fossil fuels. Generation of electrical energy by means of nuclear fuels is beneficiary in terms of large amounts of production. But nuclear energy production is known for complications such as emission of harmful gases, complications in disposal of nuclear waste, harmful radiation which in turn would affect the environment. In order to conserve the depleting fossil fuels, protect the environment from harmful nuclear radiation and to meet the ever-increasing energy requirements, a step is taken towards the renewable energy sources. The reasons that led for opting renewable sources are that they are sustainable, environment friendly and reduction in greenhouse gas emissions. While the international programs on prevention of global warming are going on the demand for electricity is also growing every year. Therefore, nations are developing less harmful sources of energy and energy production schemes like Solar PV and WECS. By developing renewable power generating system, we can reduce the number and capacity of electricity generation facilities based on fossil fuel and nuclear power.

The demand for electrical energy is increasing broadly every day. In present scenario power generation should meet not only demand but also environmental wellbeing. In this context, wind energy conversion is considered to be the most preferable renewable energy source. This has shown to the wind energy becoming a utmost contributor to the modern power system [2, 3]. The development of power electronic converters and digital processors like the micro controllers and the digital signal processors have also contributed enormously for the rapid growth of the renewable energy conversions systems. Wind is seasonal in every area, however considering the vast span of our country WECSs can be deployed throughout our country in various prime locations where wind energy is available for some time on the annual basis. Wind energy contribution to electrical grid shall not be considered as insignificant because now as the many numbers of wind turbines is connected to grid.

## II. WIND ENERGY SYSTEM

In the world, Wind energy is one of the most promising and fastest improving energy resources. Now-a-days, this energy is a required ingredient of socio-economic development and economic growth. The enhanced emphasis is being afforded on the harnessing of renewable/non-conventional energy sources in the current days. From the wind, Wind Energy Conversion Systems (WECS) are utilized to generate electrical power from mechanical power derived. WECS may control at fixed speed or variable speed. Controlling the wind turbine at a

variable speed has some attractive advantages like reduced mechanical stress in the gearbox, raised annual energy capture, the require blade control mechanism is avoided, improved controllability. Mainly a WECS is an electromechanical system which consists of wind as the source, the turbine, a generator and sink (grid/local load). Wind speed distribution is generally high in hilly areas or near the shore. For such remote locations it may be far off the grid. A WECS consists of the following subsystems like wind turbine, rotor, rotor blades, hub, gear train, drive-train, shafts, gearbox, couplings, mechanical brake, and nacelle shown in Fig.2.1.

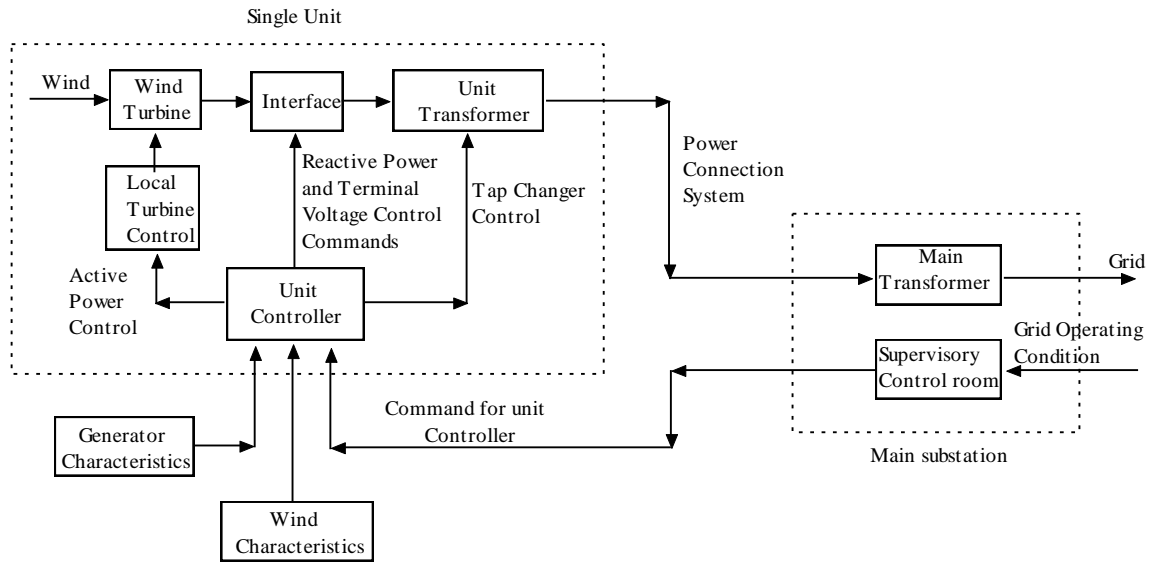

Fig. 1: Configuration of Wind Energy Conversion System

## A. Basic Principle of Wind Turbine

Heating of the earth's surface by the sun is uneven, causing large air masses to move on the surface of the earth and the wind can be defined as air in motion. This motion of air is a global, regional and local phenomenon. Regional wind is influenced by nature of the surface and global causes. WECS transforms the kinetic power of the wind into electricity. The wind turbine extracts the kinetic energy of the wind and generates rotating torque and the alternators utilizing this torque generate electrical energy, which is fed in to the grid. WTs utilize the winds very close to the surface i.e., around 100 m height from the ground. Due to the roughness of the land near the surface, the wind at this region is turbulent. The major problem in wind energy is its variable nature [4, 5]. The WT's rotor blades have a structure and construction similar to aircraft wing. When the wind goes through the rotor to blades, WTs shall derive energy from wind by transmitting the air's thrusting force. Due to this air flow through the blades, windward side has more pressure compared to the other side and this pressure difference creates a lifting force. This lifting force is changed in to mechanical torque in the rotor and this torque makes the shaft coupled to rotor rotate. This shaft can be coupled to any device to convert the power in the shaft to some useful means. For the past several years this shaft power has been utilized for grinding grain or lifting water, but the shafts of large WTs of now-a-days are coupled to generators which are integrated to power system grid to produce electric power [6, 7].

## B. Wind Power

The mechanical power obtainable from a wind turbine is as follows [8,9]:

$$P_w = 0.5 \rho \pi R^2 V_w^3 C_p(\lambda, \beta) \quad (.1)$$

where,  $P_w$  Power drawn out from the Wind,  $\rho$  is air density,  $R$  is radius of blade,  $V_w$  is wind speed and  $C_p$  is power coefficient's is called the performance coefficient. The performance coefficient is less than unity and it suggests that wind after the encounter with the wind turbine does not lose all its kinetic energy and has some kinetic energy retained in the form of velocity with the wind and this fact is a fundamental requirement that wind flows through the wind turbine. If the velocity of wind becomes zero after the encounter with the wind turbine, then there will be stagnation behind the turbine which will prevent the flow of wind in a continuous manner. Now the performance coefficient is given by

$$C_p = \frac{1}{2} * (\lambda - 0.022 * \beta^2 - 5.6) * e^{-0.17\lambda} \quad (2)$$

The tip speed ratio is specified as:

$$\lambda = \frac{V_w}{\omega_B} \quad (3)$$

where,  $\omega_B$  is Rotational Speed of Turbine

Usually  $C_p$  is approximated as,

$$C_p = \alpha\lambda + \beta\lambda^2 + \gamma\lambda^3 \quad (4)$$

where  $\alpha$ ,  $\beta$  and  $\gamma$  are practical parameters for a given turbine.

It can be shown that  $C_{pmax}$ , the maximum value for  $C_p$ , is a constant for a specified turbine. The torque developed by the wind turbine:

$$T_t = 0.5\rho\left(\frac{C_p}{\lambda}\right)V_w^3\pi R^2 \quad (5)$$

### C. Control of Wind Turbine

WTs require suitable control to run the turbine at any desired speed according to the prevailing wind velocities so that maximum power is harvested. In the active MPPT region of operation, the pitch control can be used. Beyond the rated wind velocity, the natural stall or the forced stall may be used so that the turbine speed does not cross the dangerous limit and safety is ensured. The details of these two control mechanisms are presented below: [10, 11].

#### (i) Stall control

The wind before the encounter with the wind turbine is assumed to be flowing from far away distance and is assumed to be behaviour and streamlined. After the encounter with the wind turbine at the exit, behind the wind turbine blades the wind becomes turbulent. If the wind turbine passes through the turbulent wind, there is no transmitting of power from the wind to the wind turbine. This phenomenon is known as Stalling. Stalling of wind velocity is a function of the attack angle. That is, for any wind velocity, the wind turbine can be pushed into the stalling mode by controlling the angle of attack which can be done by the pitch angle control. For a fixed pitch angle turbine, where there is no provision to change the pitch angle the stalling occurs at a particular wind velocity, this is treated as natural or unforced stalling. It happens only for a certain wind velocity, usually this happens where the pitch angle is fixed. Where there is a provision for pitch angle control, stalling can be done at any wind velocity [12].

#### (ii) Pitch Control

In the horizontal wind turbine, a number of blades typically 2 or 3 are connected on a hub and the hub rotate about horizontal axis. The blades of the wind turbine are of a long flat structure with the cross section conforming to the aerodynamic principles. The horizontal wind turbines start and run by virtue of the lift force. In some wind turbines, the area of the blades that face the wind are slightly tilted. This tilt is the means by which the angle of attack is changed and that in turn changes the power harvested by the wind turbine. In a typical, wind turbine there could be a provision to change the angle of the blade by some electromechanical, or some hydraulic means. By changing the pitch angle, the angle of attack is changed and this in turn changes the lift force developed in the wind turbine blades that adds up a rotational acceleration and causes the wind turbine to turn about the rotational axis and to run at a resulting rotational speed. Since the power harvested by a wind turbine is a function of the speed at which the turbine rotates for any given wind velocity, by changing the pitch angle the rotational speed can be changed and this can change the power output of the wind turbine [13, 14, 15].

## III. CONFIGURATION OF WIND TURBINE

In the initial stages of development of WT technology, DC machines were mainly employed for generating electrical energy from the wind energy in order to achieve decoupling between mechanical system and constant frequency electrical grid [16]. With the advent of power electronics technology and its drastic developments has facilitated the use of induction and synchronous generators in place of DC generators [17, 18]. At present there are many configurations to convert wind energy to electrical energy [19, 20]. The available configurations shall be classified based on electrical equipment, shaft and rotational speed. The classification WECSs based on rotational speed [21, 22] as under:

### A. Constant Speed Wind Turbines

The type A WT system shall operate at almost fixed speed and independent of the wind speed and its operational speed depends on connected grid frequency, gear ratio and generator design. As shown in Fig. 2.2, Squirrel Cage Induction Motor (SCIG) is employed here and its stator is directly coupled to grid. The shaft of the SCIG is connected to the WT through a gear box. As the SCIG draws reactive power for magnetization purpose,

a capacitor bank is provided for reactive power compensation [23]. This concept is very simple to implement and it does not employ power electronic circuits. In this configuration, the fluctuations in the wind are converted in to power variations and this can lead to voltage fluctuations at Point of Common Coupling PCC in case of weak grid. The foremost problems in this configuration are [24]:

- The annual yield of power is lower in comparison with variable speed configuration and hence payback period is longer.
- No speed control method is available.
- Connected grid must not be a weak grid.
- Due to voltage fluctuations, the type A configuration draws changing amounts of reactive power, which shall additionally escalates voltage variations and the line losses.
- It should withstand high mechanical stress.
- In this configuration, a three-stage gearbox in the drive train is essential and this gearbox constitutes a greater portion of mass in the nacelle, leading to increase in weight and cost of WT.

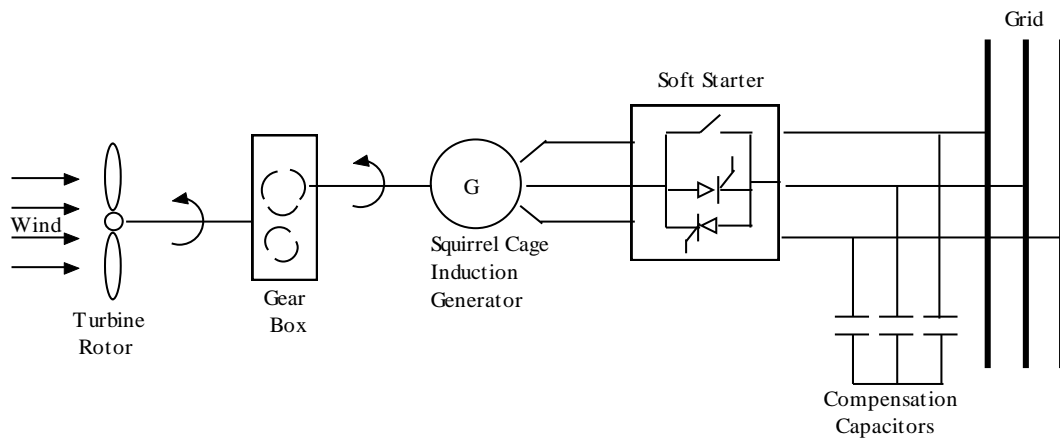

Fig. 2: Type A: Constant Speed Wind Turbines

### B. Limited Variable Speed Wind Turbines

This configuration employs Wound Rotor Induction Generator (WRIG) and it is directly coupled to the grid. Just like in Type A configuration, a capacitor bank is required for reactive power compensation and soft starter facilitates smoother connection with grid. The main feature of this configuration is that the rotor resistance is controlled by means of an optically controlled power electronics converter. By regulating the energy extracted from the rotor of WRIG, which is dissipated in the external resistor connected in the rotor, variable-speed operation is obtained in this configuration. A higher variable speed range leads to higher slip, leading to higher power extracted by rotor. This means that the external resistance must have higher rating and also leads to the decrease in generator efficiency. The speed range obtained in this configuration is in the range of 0–10% above synchronous speed. Thus the use of power electronics converter has facilitated the omission of costly slip rings and brushes. This configuration is costlier due to its complex design, but the variable speed nature of this configuration allow to extract more power from wind and also lower fluctuations in power delivered to grid. This type of WT is a popular one because it is landmark in variable speed WT, but this is made outdated by Type C configuration [25].

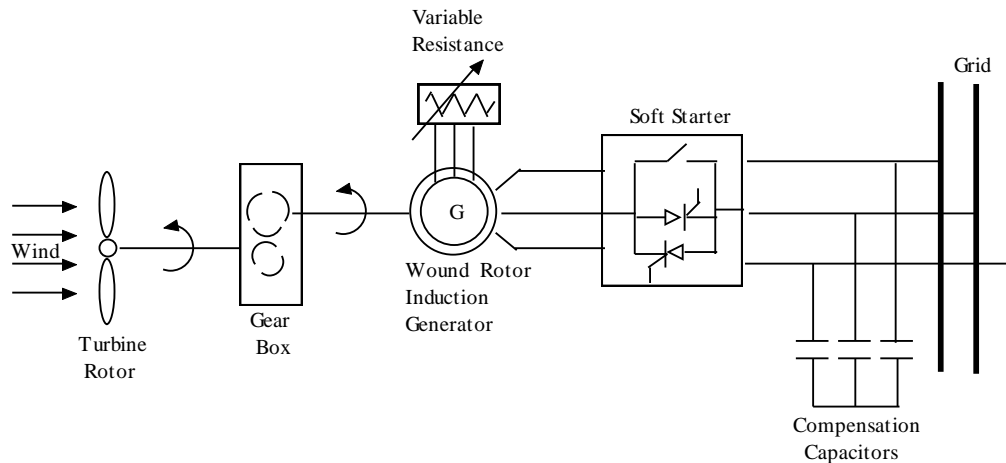

Fig. 3: Type B: Limited Variable Speed Wind Turbines

### C. Variable Speed Wind Partial Scale Turbines with Frequency Converter

This concept is a variable speed WT system and it employs WRIG. This concept is also known as Doubly-Fed Induction Generator (DFIG) concept. Its stator is directly coupled to grid and rotor is connected through slip rings to a partial scale converter, which has two back-to-back converters i.e. one is Rotor Side Converter (RSC) and the other is Line Side Converter (LSC) and they are interfaced by means of a dc-link. This configuration has the converter to control rotor frequency and thus rotor speed and it has wide range of speed control i.e. 30% around the synchronous speed [26].

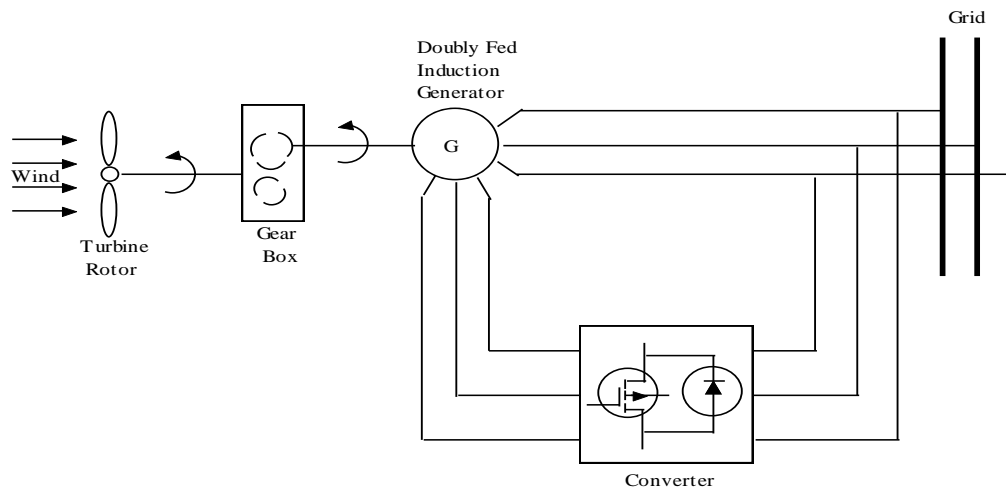

Fig.4: Variable Speed Wind Turbines with Partial Scale Converters

The various advantages of this configuration are summarized as follows:

- This configuration employs a partial scale converter and hence only 25%- 30% of the total power flows through the converters, resulting in reduced cost, size, weight and losses [27].
- Accurate and dynamic control of both active and reactive power exchange with grid can be achieved by controlling the power electronic converters.
- In type-B concept, the extracted rotor power is being dissipated in the external resistor connected in the rotor and thus wasted. Whereas in this concept, the rotor energy can be effectively utilized through feedback into the grid by the PE converter.
- Variable speed operation of WT helps to extract more wind power
- Smooth grid connection can be obtained without Soft-starter.
- Reactive power compensation is achieved without using capacitor bank.

### D. Type D: Variable Speed Wind Turbines with Full Scale Frequency Converters

This configuration of WT is a full variable speed and pitch-controlled WT. The generator is coupled to grid through a full-scale power electronic converter, which takes care of reactive power compensation and smooth grid connection over the entire speed range. The generator employed can be an electrically excited Wound Rotor

Synchronous Generator (WRSG) or Permanent Magnet Synchronous Generator (PMSG). The higher cost of permanent magnets is a limiting factor in employing for higher rating WECS. This configuration has a wide range of speed control from 0% to 100% of the synchronous speed. This configuration is employing a full scale converter and this leads to a higher cost and a higher power loss. The major consideration here in this concept is speed of the generator. As the rotor is directly coupled to WT, its operating speed is very low. To generate the required power at this low speed needs the generator to produce higher torque. Therefore a direct drive generator shall have large diameter with a large number of poles. The elimination of gear box contributes the low maintenance costs and improved reliability. This has motivated the research to enhance the applications of this gearless configuration [65, 66].

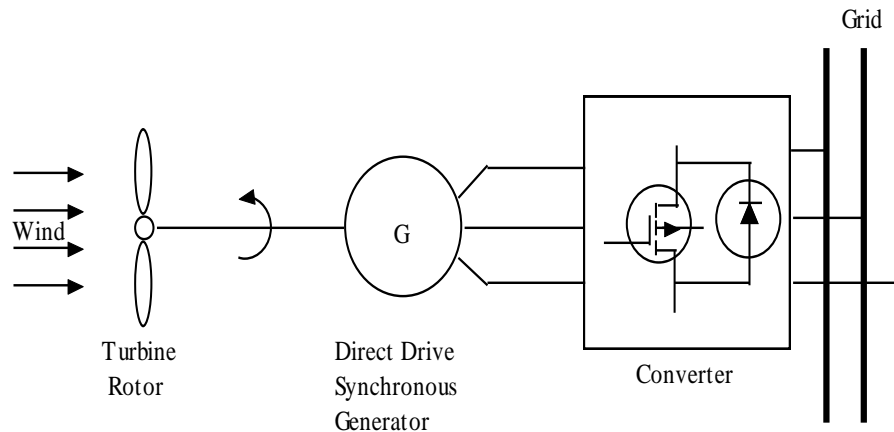

Fig. 5: Variable Speed Wind Turbines with Full-Scale Frequency Converters

#### IV. WIND TURBINE GENERATOR

Generators of various types are in use for a wind energy conversion system. For grid oriented applications, sophisticated wind turbines are used which are usually three-phase AC machines that are designed using modern techniques. A WT can be connected with any type of available three- phase generator. Even the generator supplies AC with variable frequency or DC, the grid compatibility can be met by connecting converters. The following are the types of generators that are being used in WECS [28]

##### A. Squirrel Cage Induction Generator

Squirrel Cage Induction Generator (SCIG) is the most widely used generator for WECS for a long time. SCIG is most commonly connected to grid directly. Due to advantages like reduced mechanical effort, robustness and low cost, asynchronous induction generator is mostly used in wind mills [19]. It does not require slip rings and a separate excitation system. Reactive power from the grid will be drawn by generator and it is compensated with the help of capacitors to achieve power factor near to unity, thus modifying it as a self-excited induction machine. Speed varies over a very small range which is negligible and so this machine is also named as fixed speed generator. The motor or generator mode of operation of SCIG is stable around the narrow region near synchronous speed  $N_s$ . The speed changes are very negligible and hence the WTs connected with SCIG are known as fixed speed systems. SCIG has the following advantages [29]:

- Simple and rugged construction.
- Economical due its simple construction and mass production.
- High efficiency and very low maintenance cost.
- No need of any separate magnetizing circuit and source for magnetization.

The drawbacks of SCIG are listed below:

- The SCIG is termed as a constant speed generator and the speed variation is possible in a very narrow range. This has the following implications:
  - There will be a speed of turbine that results in highest value of  $C_p$  for WT that gives the optimum efficiency for every wind speed. This optimal speed cannot be obtained instantly with a SCIG as the speed cannot be varied continuously.
  - The SCIG operates at a speed around 1500 rpm or 1000 rpm but the WT operates at a speed of 10 - 25 rpm, hence the Gearbox is required the most of the mass of the nacelle, and also a Gearbox is maintenance intensive and is of malfunction. gearbox constitutes portion of the investment costs. potential cause.

- In SCIGs, there is a voltage an rotor speed during high winds, SCIG must draw corresponding high reactive power

## **B. Wound Rotor Induction Generator**

WRIG having a variable external rotor resistance in the rotor windings. Energy drawn from rotor circuit of WRIG is controlled accordingly for accomplishing variable-speed operation. Amount of power loss in rotor circuit depends on the value of variable resistance and amount of heat dissipated. For achieving wide speed range, value of variable resistor should be high so that high power can be obtained from rotor circuit; thereby efficiency of generator is improved. Thus the size and rating of variable rotor resistance is a significant factor that decides the speed control range of the machine. The combination of controlled converter, external resistance in rotor circuit and optical coupling circuit for transmission of control signals led to the elimination of slip rings. A converter is employed in the rotor to change the total rotor resistance so as to modify the slip of the OSIG. The converter being optically controlled, needs no slip rings and the stator of OSIG is coupled directly to the grid [30].

## **C. Doubly-Fed Induction Generator**

The DFIG has the stator constructed in similar to that of SCIG. But the rotor is constructed with three phase winding, unlike squirrel cage rotor, connected to grid through IGBT based converter. The stator has voltage due to its connection to grid and the rotor has induced voltage due to PE converter and thus the term doubly fed is used here. The PE converter injects currents with variable frequency to balance the mechanical and electrical frequency. Both during normal operation and faults the behavior of DFIG is governed by the PE converter and its controllers. Rotor side converter (RSC) and (LSC) are controlled independently and this converter allows the flow of power in both ways, i.e. from grid to rotor and from rotor to grid. Basically wind speed in a variable quantity. Hence in this process, the use of induction generator over the synchronous generator is most beneficial. Due to its asynchronous property the induction generator can generate electricity at variable speeds. Also the use of induction generator is valuable because it is relatively economical, robust, and requires low maintenance. The advantages of DFIG are [31]:

- It achieves reactive power control and decoupled active and reactive power control.
- DFIG shall not take any magnetizing current from the grid. The reactive power required for magnetization is delivered to stator by the grid-side converter. But, the grid-side converter usually operates at unified power flow (UPF) and do not exchange reactive power between the WT and the grid. DFIG may generate or absorb reactive power to or from the grid to control voltage in weak grid.
- The converter rating does not depend on the output of the DFIG but instead depends on the selected speed range, which in turn depends on the slip power. Therefore, the converter shall be costlier with wider speed range.

## **D. Permanent Magnet Synchronous Generator (PMSG)**

In PMSG, the rotor construction is different, whereas the stator construction is similar to External Excitation Synchronous Generator (EESG). The rotor consists of permanent magnets instead of winding excited by DC supply. The PMSG permits a more compact design that leads to generators with smaller diameters and smaller mass. Various studies on design options for PMSG for WTs have been done in [32]. The main feature of this type of generators is that they do not depend on any external sources for setting the rotor magnetic field as it is provided by permanent magnets built in the generator. Power is produced by this generator during high speeds that provides sufficient conditions to run the rotor at speed higher than that of stator magnetic field. This increases rotor speed and hence increases frequency of the system by a small fraction. When speeds are too low then they operate in motor mode and consume power from the network. This operation is done with the help of a drive that runs the system at low frequency during low speeds and at high frequency during high speeds.

The advantages of PMSG over EESG can be summarized as follows:

- Superior efficiency and energy generation.
- Thermal characteristics are better due to lack of field losses,
- Absence of slip rings and brushes leads to better reliability.
- Lightweight design yields higher power to weight ratio.

## V. CONCLUSION

An attempt has been made in this chapter to discuss the most-recent research trends in the field of wind energy conversion systems. From the study, it can be concluded that in case of generators and converters, most system adopts DFIG with back-to-back converter due to their less weight and cost. However, for the large capacity wind turbines where efficiency and reliability plays a major role has been utilizing PMSG's even though it has more weight and increased installation cost. Moreover, WECS based on the multibrid concept, will become more attractive alternative technology in the future. Regarding the controllers for the WECS, is still the most important and challenging topic of research as there are various controllers had been proposed by various researchers has been discussed in this paper. As there are lot of ongoing developments takes place at various stages of WECS, it is noted that the most suitable (optimized) solutions to extract maximum power of the installed system is ad-hoc, rather than generalized solution. The overview of this information highlights the current research progress in the field of wind energy conversion system and this will be helpful for the new researchers to focus on the above area.

## REFERENCES

- [1] 20% Wind Energy by 2030. (July, 2008). Retrieved from <http://www.osti.gov/bridge/switching>
- [2] Wind Energy
- [3] T. Ackermann, "Wind Power in Power Systems", First edition, 2005, John Wiley and Sons Ltd, West Sussex, PO19 8SQ, United Kingdom.
- [4] Gary L. Johnson, "Wind Energy Systems", Prentice Hall Inc., Englewood. Cliff, NJ, 1985
- [5] Z. Chen and F. Blaabjerg, "Wind energy: The world's fastest growing energy source", IEEE Power Electronics Society Newsletter, vol. 18, no. 3, pp. 15–19, 2006.
- [6] J. Andrews and N. Jelley, Energy Science - principles, technologies and impacts, Oxford University Press, 116-117 High St, Oxford, U.K., 2007.
- [7] R. Zavadil, N. Miller, A. Ellis, E. Muljadi, E. Camm, and B. Kirby, "Queuing up", Power and Energy Magazine, IEEE, vol. 5, no. 6, pp. 47 – 58, Nov.-Dec. 2007.
- [8] S. Heier, Grid Integration of Wind Energy Conversion Systems, J. Wiley & Sons, 111, River Street, Hoboken, NJ 07030-5774, US, 1998
- [9] E. Muljadi, C. P. Butterfield, J. Chacon, and H. Romanowitz, "Power quality aspects in a wind power plant", in Power Engineering Society General Meeting, 2006, Montreal, Canada, 18-22 June 2006.
- [10] Wachtel S., J. Marques, E. Quitman, and M. Schellschmidt, "Wind energy converters with FACTS capabilities and the benefits for the integration of wind power plants into power systems," in Proc. European Wind Energy Conference and Exhibition (EWEC), Milan, 4, May 7-10 2007, pp. 1761–65.
- [11] F. Blaabjerg and Z. Chen, Power Electronics for Modern Wind Turbines, Synthesis Lectures on Power Electronics. Morgan & Claypool, U.S., 2006
- [12] Wind in numbers. Retrieved from <http://gwec.net/global-figures/wind-innumbers>.
- [13] Branko M. Radičević, Milan S. Savić, Soren Find Madsen, and IonBadea, "Impact of wind turbine blade rotation on the lightning strike incidence – A theoretical and experimental study using a reduced-size model" Energy, Volume 45, Issue 1, September 2012, Pages 644-654.
- [14] B. Parson, M. Milligan, B. Zavadil, D. Brooks, B. Kirby, K. Dragoon, and J. Caldwell, "Grid impacts of wind power: A summary of recent studies in the United States", Wind Energy, vol. 7, no. 1, pp. 87–108, Apr./Jun. 2004.
- [15] R. A. Walling, R. Saint, R. C. Dugan, J. Burke, and L. A. Kojovic "Summary of distributed resources impact on power delivery systems", IEEE Transactions on Power Del., vol. 23, no. 3, pp. 1636 – 44, July 2008
- [16] J. C. Smith, M. R. Milligan, E. A. DeMeo, and B. Parsons, "Utility wind integration and operating impact state of the art", IEEE Transactions on Power System, vol. 22, no. 3, pp.900–908, Aug. 2007..
- [17] C. Kalich J. King M. R. Milligan C. Murlay B. Oakleaf E. A. DeMeo, G. A. Jordan and M. J. Schuenger, "Accommodating wind's natural behavior", Power and Energy Magazine, IEEE, vol. 5, no. 6, pp. 59–67, Nov.-Dec. 2007.
- [18] "Integration of Renewable Energy in the Electrical Network in 2010", draft final report, EU ALTENER PROJECT XVII/4.1030/Z/99-115, Brussels- Belgium, 2001.
- [19] J. M. Carrasco *et al*, "Power-Electronic Systems for the Grid Integration of Renewable Energy Sources: A Survey", *IEEE Trans. on Industrial Electronics*, vol. 53, no. 4, pp. 1002-1016,2016.
- [20] J.J. Gutierrez, J. Ruiz, P. Saiz, I. Azcarate, L.A. Leturiondo and A. Lazkano (2011), "Power quality in Grid-Connected wind turbines", Dr. Ibrahim Al- Bahadly (Ed.), InTech, DOI: 10.5772/15175.
- [21] Francisco C.De La Rosa "Harmonics and Power Systems" CRC press, First Indian Print.



- [22] IEEE Working Group on Power System Harmonics "Power System Harmonics: An Overview" IEEE Power Engineering Review, Vol.3, No.8, pp. 27-28, Aug-1983
- [23] T.C.Shuter, H.T.Vollkommer and Jr.T.L.Kirkpatrick "Survey of Harmonic Levels on the American Electric Power Distribution System" IEEE Transactions on Power Delivery, Vol. 4, No. 4, pp.2204-2213, Oct-1989.
- [24] Christopher K. Duffey and Ray. P. Stratford "Update of Harmonic Standard IEEE-519: IEEE Recommended Practices and Requirements for Harmonic Control in Electric Power Systems" IEEE Trans on Industrial Applications, Vol.25, No.6, pp.1025-1034, Nov/Dec-1989.
- [25] Joseph S. Subjak., JR and John S. Mcquilkin "Harmonics - Causes, Effects, Measurements, and Analysis: An Update" IEEE Transactions on Industrial Applications, Vol.26, No.6, pp.1034-1042, Nov/Dec-1990.
- [26] Alexander E. Emanuel, John A. Orr, David Cyganski and Edward M. Gulachenski, "A Survey of Harmonic Voltages and Currents at the Customer's Bus" IEEE Transactions on Power Delivery, Vol. 8, No. 1, pp.411-421, Jan- 1993.
- [27] IEEE Working group on Non-sinusoidal Situations "Practical Definitions for Powers in Systems with Non sinusoidal Waveforms and Unbalanced Loads: A Discussion" IEEE Transactions on Power Delivery, Vol. 11, No. 1, pp.79-87, Jan-1996.
- [28] Eric J. Davis, Alexander E. Emanuel and David J. Pileggi "Harmonic Pollution Metering: Theoretical Considerations" IEEE Transactions on Power Delivery, Vol. 15, No. 1, pp.19-23, Jan-2000.
- [29] F.Z.Peng, H.Akagi and A.Nabae "A Novel Harmonic Power Filter" PESC, pp.1151-1158, April-1988.
- [30] Burton T, Sharpe D, Jenkins N and Bossanyi E, Wind Energy Handbook, John Wiley & Sons Ltd, Chichester, 2001
- [31] Ton van de Wekken, and Fred Wien, "wind power", Power Quality and Utilisation Guide Section 8 – Distributed Generation, Issue Autumn 2006.
- [32] R.C. Bansal, T.S. Bhatti, D.P. Kothari "On some of the design aspects of wind energy conversion systems", Energy Conversion and Management, volume 43, Issue 16, pp. 2175-2187.
- [33] D. M. Eggleston, F. S. Stoddard, Wind Turbine Engineering Design, New York,NY: Van Nostrand Reinhold Company, 1987.
- [34] D. A. Spera (editor), Wind Turbine Technology. New York, NY: ASME Press, 1994.
- [35] S. Heier, Grid Integration of Wind Energy Conversion Systems, West Sussex, England: John Wiley & Sons, 1998.