

Generalized fractional Hirota–Satsuma coupled KdV system using Caputo-Fabrizio operator

Shankar R. Raut

Department of Mathematics, Mrs. K.S.K. College, Beed-431122, India
email: shankar.kskm123@gmail.com

Abstract

The main aim of this study is to present analysis of a generalized fractional Hirota–Satsuma coupled KdV system. The fractional derivatives are described in terms of Caputo-Fabrizio sense. Picard successive approximation technique and Banach’s fixed point theory have been used for verification of existence and stability criteria. The approximate solutions of the problem in the form of rapidly convergent series are computed using iterative Laplace transform technique with easily calculable components using Mathematica. Reliability of the proposed method and Caputo-Fabrizio is given by comparison with other method in the literature. Further, we show graphical illustration for some values of the fractional order in order to show the effectiveness of the proposed method.

Keywords : Iterative Laplace transform, Time fractional Hirota-Satsuma coupled KdV systems; Caputo-Fabrizio operator; Existence and Stability; Approximate solutions.

2010 Mathematics Subject Classifications : Primary: 26A33, 33E12 34A08, 35R11

1 Introduction

As is well known, researchers have recognized that the fractional calculus can provide more flexible descriptions than the counterpart of integer-order for the real-world phenomena arising in various fields of science and engineering. Differential equations of fractional order are the center of attention of many studies due to their usefulness in the areas of chaos theory [3], physics, material science, electrochemistry, acoustics, viscoelasticity, mechanics, electromagnetic, signal and image processing, reaction processes, [25, 24, 23, 20] biomathematics [4], financial models [35] . Due to the complicated nature of fractional calculus, most of the fractional order differential equations do not have the exact solutions, hence considerable focus is to get approximate solutions of these equations. Some of the recent methods for approximate solutions of these equations are the Adomian decomposition method [2, 7], Homotopy analysis method [21, 18], Variational iteration method [13], Differential transform method [27], Iterative Laplace transform method [28], Homotopy-perturbation method [14], Fractional complex transform [31, 32], Finite-difference method [36], the (G'/G) -expansion method [39]. Since fractional calculus was put forward in the seventeenth

century, there have appeared several definitions of fractional derivatives: Riemann-Liouville, Caputo, Hadamard, Grunwald-Letnikov etc [5]. To unify these fractional derivatives, some generalized fractional operators such as Hilfer fractional operator [15], Katugampola fractional operator [17], and Atangana-Baleanu fractional operator [1, 9], Caputo-Fabrizio operator [29, 10, 33] etc. were presented.

In 1981, R. Hirota and J. Satsuma introduced a coupled Korteweg-de Vries (KdV) equation known as the Hirota-Satsuma coupled KdV system to examine an interaction of two long waves with diverse dispersion relations. In recent times, many researchers have devoted considerable efforts by successfully implementing various techniques to extract solitary wave solutions and other solutions of Hirota-Satsuma coupled KdV systems. In [11] Fan obtained Soliton solution for a generalized Hirota-Satsuma coupled KdV equation. Exact travelling wave solutions are presented in [19] by Khater et. al. Solution of time-fractional generalized Hirota-Satsuma coupled KdV equation is obtained in [22]. An Efficient Computational Technique for Fractional Model of Generalized Hirota-Satsuma-Coupled Korteweg-de Vries and Coupled Modified Korteweg-de Vries Equations is studied by Veersha et. al. in [37]. Solitary Wave Solutions for a Time-Fraction Generalized Hirota-Satsuma Coupled KdV Equation by a New Analytical Technique investigated in [30]. In [38] Wu et. al. introduced a 4×4 matrix spectral problem with three potential and derived new hierarchy of nonlinear evolution equation which are a generalized Hirota-Satsuma KdV (Korteweg-De Vries) equations, and several other studies about fractional generalized Hirota-Satsuma coupled KdV system are investigated in [34, 26, 12, 16].

Motivated by above literature study, in this work, we consider the time fractional generalized Hirota-Satsuma coupled KdV system presented by a system of partial differential equations with Caputo-Fabrizio operator to find approximate solution. The time fractional generalized Hirota-Satsuma coupled KdV system is given as

$$\begin{cases} {}^{CF}D_t^\beta u = \frac{1}{2}u_{xxx} - 3uu_x + 3(vw)_x \\ {}^{CF}D_t^\beta v = -v_{xxx} + 3uv_x \\ {}^{CF}D_t^\beta w = -w_{xxx} + 3uw_x \end{cases} \quad t > 0, \quad 0 < \beta \leq 1 \quad (1.1)$$

with initial conditions [11] as follows

$$\begin{cases} u(x, 0) = \frac{\gamma - 2m^2}{3} + 2m^2 \tanh^2(mx) \\ v(x, 0) = -\frac{4m^2\sigma(\gamma + m^2)}{3\tau^2} + \frac{4m^2(\gamma + m^2)\tanh(mx)}{3\tau} \\ w(x, 0) = \sigma + \tau \tanh(mx) \end{cases} \quad (1.2)$$

where $m, \sigma, \tau \neq 0$, and γ are arbitrary constants.

The systems Eq.1.1 becomes classical given in [38] for $\beta = 1$.

The rest of this paper is sorted out as follows. In Section 2, preliminary results and definitions related with fractional calculus are presented. In Section 3, iterative Laplace transform method pertaining to novel Caputo-Fabrizio derivative operator is discussed. In Section 4, we center around the verification of existence and stability criteria by utilizing Picard successive approximation technique and fixed point theory due to Banach. In Section 5, the proposed technique is applied to fractional Hirota–Satsuma KdV system and simulations are done with plots and tables. Finally, the conclusions are given in Section 6.

2 Preliminaries

Definition 2.1 ([8]) Let $u \in H^1(0, b)$, $b > 0, 0 < \beta < 1$, then time fractional Caputo-Fabrizio fractional differential operator is defined as

$${}^{CF}D_t^\beta u(t) = \frac{(2-\beta)N(\beta)}{2(1-\beta)} \int_0^t \exp\left[-\frac{\beta(t-s)}{1-\beta}\right] u'(\tau) d\tau, \quad t \geq 0, \quad 0 < \beta < 1, \quad (2.1)$$

where $N(\beta)$ is a normalisation function depending on β such that $N(0) = N(1) = 1$.

Definition 2.2 ([6]) The Caputo-Fabrizio fractional integral operator of order $0 < \beta < 1$ is given by

$${}^{CF}J_t^\beta u(t) = \frac{2(1-\beta)}{(2-\beta)N(\beta)} u(t) + \frac{2\beta}{(2-\beta)N(\beta)} \int_0^t u(\tau) d\tau, \quad (2.2)$$

like usual Caputo derivative, this new operator gives ${}^{CF}D_t^\beta u(t) = 0$, if u is a constant function.

The main advantage of Caputo-Fabrizio operator over old operator of Caputo is that there is no singularity for $t = s$ in the new kernel.

Definition 2.3 ([8]) The Laplace transform for the Caputo-Fabrizio fractional operator of order $0 < \beta \leq 1$ and $m \in \mathbb{N}$ is given by

$$\begin{aligned} L({}^{CF}D_t^{m+\beta} u(t))(s) &= \frac{1}{1-\beta} L(u^{(m+1)}(t)) L\left(\exp\left(-\frac{\beta}{1-\beta}t\right)\right) \\ &= \frac{s^{m+1}L(u(t)) - s^m u(0) - s^{m-1}u'(0) - \dots - u^{(m)}(0)}{s + \beta(1-s)}. \end{aligned} \quad (2.3)$$

In particular, we have

$$\begin{aligned} L({}^{CF}D_t^\beta u(t))(s) &= \frac{sL(u(t))}{s + \beta(1-s)}, \quad m = 0. \\ L({}^{CF}D_t^{\beta+1} u(t))(s) &= \frac{s^2L(u(t)) - su(0) - u'(0)}{s + \beta(1-s)}, \quad m = 1. \end{aligned}$$

3 Iterative Laplace Transform Method

Consider the Hirota-Satsuma coupled KdV system Eq.1.1 having initial conditions Eq.1.2 Applying the Laplace transform both side on system, we obtain,

$$\frac{sL(u(t)) - u(0)}{s + \beta(1 - s)} = L\left(\frac{1}{2}u_{xxx} - 3uu_x + 3(vw)_x\right) \quad (3.1)$$

$$\frac{sL(v(t)) - v(0)}{s + \beta(1 - s)} = L(-v_{xxx} + 3uv_x) \quad (3.2)$$

$$\frac{sL(w(t)) - w(0)}{s + \beta(1 - s)} = L(-w_{xxx} + 3uw_x) \quad (3.3)$$

Rearranging, we get

$$L(u(t)) = \frac{u(0)}{s} + \left(\frac{s + \beta(1 - s)}{s}\right)L\left(\frac{1}{2}u_{xxx} - 3uu_x + 3(vw)_x\right) \quad (3.4)$$

$$L(v(t)) = \frac{v(0)}{s} + \left(\frac{s + \beta(1 - s)}{s}\right)L(-v_{xxx} + 3uv_x) \quad (3.5)$$

$$L(w(t)) = \frac{w(0)}{s} + \left(\frac{s + \beta(1 - s)}{s}\right)L(-w_{xxx} + 3uw_x) \quad (3.6)$$

Further the inverse Laplace transform on equation (3.4) to (3.6), yields

$$u(t) = u(0) + L^{-1}\left[\left(\frac{s + \beta(1 - s)}{s}\right)L\left(\frac{1}{2}u_{xxx} - 3uu_x + 3(vw)_x\right)\right] \quad (3.7)$$

$$v(t) = v(0) + L^{-1}\left[\left(\frac{s + \beta(1 - s)}{s}\right)L(-v_{xxx} + 3uv_x)\right] \quad (3.8)$$

$$w(t) = w(0) + L^{-1}\left[\left(\frac{s + \beta(1 - s)}{s}\right)L(-w_{xxx} + 3uw_x)\right] \quad (3.9)$$

The infinite series solutions obtained by this method given as,

$$u = \sum_{n=0}^{\infty} u_n, \quad v = \sum_{n=0}^{\infty} v_n, \quad w = \sum_{n=0}^{\infty} w_n. \quad (3.10)$$

The nonlinearity uu_x , $(vw)_x$, uv_x and uw_x can be written as

$$uu_x = \sum_{n=0}^{\infty} G_n, \quad (vw)_x = \sum_{n=0}^{\infty} H_n, \quad uv_x = \sum_{n=0}^{\infty} I_n, \quad uw_x = \sum_{n=0}^{\infty} J_n$$

where G_n , H_n , I_n and J_n are decomposed as follows

$$\begin{aligned} G_n &= \sum_{i=0}^n u_i \sum_{i=0}^n (u_i)_x - \sum_{i=0}^{n-1} u_i \sum_{i=0}^{n-1} (u_i)_x \\ H_n &= \left(\sum_{i=0}^n u_i \sum_{i=0}^n w_i \right)_x - \left(\sum_{i=0}^{n-1} u_i \sum_{i=0}^{n-1} w_i \right)_x \\ I_n &= \sum_{i=0}^n u_i \sum_{i=0}^n (v_i)_x - \sum_{i=0}^{n-1} u_i \sum_{i=0}^{n-1} (v_i)_x \\ J_n &= \sum_{i=0}^n u_i \sum_{i=0}^n (w_i)_x - \sum_{i=0}^{n-1} u_i \sum_{i=0}^{n-1} (w_i)_x \end{aligned}$$

We next obtain the following recursive formula by using initial conditions

$$u_{n+1}(t) = u_0 + L^{-1} \left[\left(\frac{s + \beta(1-s)}{s} \right) L \left(\frac{1}{2} u_{nxxx} - 3u_n u_{nx} + 3(v_n w_n)_x \right) \right] \quad (3.11)$$

$$v_{n+1}(t) = v_0 + L^{-1} \left[\left(\frac{s + \beta(1-s)}{s} \right) L(-v_{nxxx} + 3u_n v_{nx}) \right] \quad (3.12)$$

$$w_{n+1}(t) = w_0 + L^{-1} \left[\left(\frac{s + \beta(1-s)}{s} \right) L(-w_{nxxx} + 3u_n w_{nx}) \right]. \quad (3.13)$$

4 Stability analysis of iteration method

Consider $(\mathbb{B}, \|\cdot\|)$ as a Banach space and define λ as self-map of \mathbb{B} . Also $\varsigma_{n+1} = \omega(\lambda, \varsigma_n)$ denotes precise recurring process. Assume that, $F(\lambda)$ denotes fixed-point set on \mathbb{B} . Also λ consist of minimum one element such that ς_n converges to point $j \in F(\lambda)$. Let $\{x_n \in \mathbb{B}\}$ and define $p_n = \|x_{n+1} - \omega(\lambda, x_n)\|$. If $\lim_{n \rightarrow \infty} p_n = 0$ implies that $\lim_{n \rightarrow \infty} x^n = j$, then the iteration method $\varsigma_{n+1} = \omega(\lambda, \varsigma_n)$ is known as λ -stable. Comparably, we, in this manner, think about that, this sequence $\{x_n\}$ has an upper bound. This iteration is known as Picard's iteration and it is λ -stable, if all these conditions are fulfilled for $\varsigma_{n+1} = \lambda \varsigma_n$.

Theorem 4.1 Consider $(\mathbb{B}, \|\cdot\|)$ as a Banach space and define λ as self-map on \mathbb{B} satisfying

$$\|\lambda_x - \lambda_y\| \leq \phi \|X - \lambda_x\| + \psi \|x - y\|$$

for all $x, y \in \mathbb{B}$ where $0 \leq \phi$, $0 \leq \psi < 1$. Assume that λ is Picard λ -stable. Consider

the equations from (3.11) to (3.13) connected to Eq.1.1 .

$$\begin{aligned} u_{n+1}(t) &= u_0 + L^{-1} \left[\left(\frac{s + \beta(1-s)}{s} \right) L \left(\frac{1}{2} u_{nxxx} - 3u_n u_{nx} + 3(v_n w_n)_x \right) \right] \\ v_{n+1}(t) &= v_0 + L^{-1} \left[\left(\frac{s + \beta(1-s)}{s} \right) L (-v_{nxxx} + 3u_n v_{nx}) \right] \\ w_{n+1}(t) &= w_0 + L^{-1} \left[\left(\frac{s + \beta(1-s)}{s} \right) L (-w_{nxxx} + 3u_n w_{nx}) \right] \end{aligned}$$

where $\frac{s + \beta(1-s)}{s}$ is a fractional Lagrange multiplier

Theorem 4.2 Consider a self-map λ defined as

$$\begin{aligned} \lambda(u_n(t)) &= u_{n+1}(t) = u_0 + L^{-1} \left[\left(\frac{s + \beta(1-s)}{s} \right) L \left(\frac{1}{2} u_{nxxx} - 3u_n u_{nx} + 3(v_n w_n)_x \right) \right] \\ \lambda(v_n(t)) &= v_{n+1}(t) = v_0 + L^{-1} \left[\left(\frac{s + \beta(1-s)}{s} \right) L (-v_{nxxx} + 3u_n v_{nx}) \right] \\ \lambda(w_n(t)) &= w_{n+1}(t) = w_0 + L^{-1} \left[\left(\frac{s + \beta(1-s)}{s} \right) L (-w_{nxxx} + 3u_n w_{nx}) \right] \end{aligned}$$

is λ -stable in $L^1(a, b)$ if

$$\begin{cases} \left\{ \frac{1}{2} \varrho_1 \varrho_2 \varrho_3 \chi_1(\beta) - 3\kappa_1 \tau_1 \chi_2(\beta) - 3\kappa_4 \chi_3(\beta) + 3\kappa_5 \chi_4(\beta) \right. \\ \quad \left. + 3\kappa_3 \tau_2 \chi_5(\beta) + 3\kappa_2 \tau_3 \chi_6(\beta) + 3\kappa_6 \chi_7(\beta) \right\} < 1, \\ -(\varrho_4 \varrho_5 \varrho_6) \xi_1(\beta) + 3\kappa_1 \tau_2 \xi_2(\beta) + 3\kappa_7 \xi_3(\beta) < 1, \\ -(\varrho_7 \varrho_8 \varrho_9) \pi_1(\beta) + 3\kappa_1 \tau_3 \pi_2(\beta) + 3\kappa_8 \pi_3(\beta) < 1 \end{cases} \quad (4.1)$$

Proof. Here, we will show that λ has a fixed point. Hence, for all $(m, n) \in N \times N$ we evaluate the followings.

$$\begin{aligned} \lambda(u_n(t)) - \lambda(u_m(t)) &= L^{-1} \left[\left(\frac{s + \beta(1-s)}{s} \right) L \left(\frac{1}{2} u_{nxxx} - 3u_n u_{nx} + 3(v_n w_n)_x \right) \right] \\ &\quad - L^{-1} \left[\left(\frac{s + \beta(1-s)}{s} \right) L \left(\frac{1}{2} u_{mxxx} - 3u_m u_{mx} + 3(v_m w_m)_x \right) \right], \end{aligned} \quad (4.2)$$

$$\begin{aligned} \lambda(v_n(t)) - \lambda(v_m(t)) &= L^{-1} \left[\left(\frac{s + \beta(1-s)}{s} \right) L (-v_{nxxx} + 3u_n v_{nx}) \right] \\ &\quad - L^{-1} \left[\left(\frac{s + \beta(1-s)}{s} \right) L (-v_{mxxx} + 3u_m v_{mx}) \right], \end{aligned} \quad (4.3)$$

$$\begin{aligned} \lambda(w_n(t)) - \lambda(w_m(t)) &= L^{-1} \left[\left(\frac{s + \beta(1-s)}{s} \right) L(-w_{nxxx} + 3u_n w_{n_x}) \right] \\ &\quad - L^{-1} \left[\left(\frac{s + \beta(1-s)}{s} \right) L(-w_{mxxx} + 3u_m w_{m_x}) \right]. \end{aligned} \quad (4.4)$$

By taking norm on both sides (4.2), and without loss of generality, we get

$$\begin{aligned} \|\lambda(u_n(t)) - \lambda(u_m(t))\| &= \left\| L^{-1} \left[\left(\frac{s + \beta(1-s)}{s} \right) L \left(\frac{1}{2} u_{nxxx} - 3u_n u_{n_x} + 3(v_n w_n)_x \right) \right] \right. \\ &\quad \left. - L^{-1} \left[\left(\frac{s + \beta(1-s)}{s} \right) L \left(\frac{1}{2} u_{mxxx} - 3u_m u_{m_x} + 3(v_m w_m)_x \right) \right] \right\|, \end{aligned} \quad (4.5)$$

Using triangular inequality and further simplifying (4.5) yields

$$\begin{aligned} \|\lambda(u_n(t)) - \lambda(u_m(t))\| &\leq L^{-1} \left[\left(\frac{s + \beta(1-s)}{s} \right) L \left[\left\| \frac{1}{2} (u_{nxxx} - u_{mxxx}) \right\| + \left\| -3u_m (u_{n_x} - u_{m_x}) \right\| \right. \right. \\ &\quad \left. \left. + \left\| -3u_{n_x} (u_n - u_m) \right\| + \left\| 3v_{m_x} (w_n - w_m) \right\| + \left\| 3w_n (v_{n_x} - v_{m_x}) \right\| \right. \right. \\ &\quad \left. \left. + \left\| 3v_m (w_{n_x} - w_{m_x}) \right\| + \left\| 3w_{n_x} (v_n - v_m) \right\| \right] \right] \end{aligned} \quad (4.6)$$

As both the solutions play the similar part, we shall assume that

$$\begin{aligned} \|u_n(t) - u_m(t)\| &= \|v_n(t) - v_m(t)\| \\ \|u_n(t) - u_m(t)\| &= \|w_n(t) - w_m(t)\| \\ \|u_{n_x}(t) - u_{m_x}(t)\| &= \tau_1 \|u_n(t) - u_m(t)\| \\ \|v_{n_x}(t) - v_{m_x}(t)\| &= \tau_2 \|v_n(t) - v_m(t)\| \\ \|w_{n_x}(t) - w_{m_x}(t)\| &= \tau_3 \|w_n(t) - w_m(t)\| \\ \|u_{nxxx}(t) - u_{mxxx}(t)\| &= \varrho_1 \varrho_2 \varrho_3 \|u_n(t) - u_m(t)\|. \end{aligned}$$

Replacing this in (4.6), we obtain the following relation

$$\begin{aligned} \|\lambda(u_n(t)) - \lambda(u_m(t))\| &\leq L^{-1} \left[\left(\frac{s + \beta(1-s)}{s} \right) L \left[\left\| \frac{1}{2} \varrho_1 \varrho_2 \varrho_3 (u_n - u_m) \right\| \right. \right. \\ &\quad \left. \left. + \left\| -3u_m \tau_1 (u_n - u_m) \right\| + \left\| -3u_{n_x} (u_n - u_m) \right\| \right. \right. \\ &\quad \left. \left. + \left\| 3v_{m_x} (u_n - u_m) \right\| + \left\| 3w_n \tau_2 (u_n - u_m) \right\| \right. \right. \\ &\quad \left. \left. + \left\| 3v_m \tau_3 (u_n - u_m) \right\| + \left\| 3w_{n_x} (u_n - u_m) \right\| \right] \right]. \end{aligned} \quad (4.7)$$

$$\begin{aligned} &\quad \left. \left. + \left\| 3v_m \tau_3 (u_n - u_m) \right\| + \left\| 3w_{n_x} (u_n - u_m) \right\| \right] \right]. \end{aligned} \quad (4.8)$$

Also $u_m, v_m, w_n, u_{n_x}, v_{m_x}$ and w_{n_x} are convergent sequence hence they are bounded. Therefore, we can obtain different positive constants, $\kappa_1, \kappa_2, \kappa_3, \kappa_4, \kappa_5$ and κ_6 for all t such as,

$$\begin{aligned} \|u_m\| < \kappa_1, \quad \|v_m\| < \kappa_2, \quad \|w_n\| < \kappa_3, \quad \|u_{n_x}\| < \kappa_4, \\ \|v_{m_x}\| < \kappa_5, \quad \|w_{n_x}\| < \kappa_6, \quad \|v_{n_x}\| < \kappa_7, \quad \|w_{n_x}\| < \kappa_8. \end{aligned} \quad (m, n) \in \mathbb{N} \times \mathbb{N} \quad (4.9)$$

Next consider equation (4.8) and (4.9), we get

$$\begin{aligned} \|\lambda(u_n(t)) - \lambda(u_m(t))\| \leq & \left\{ \frac{1}{2} \varrho_1 \varrho_2 \varrho_3 \chi_1(\beta) - 3\kappa_1 \tau_1 \chi_2(\beta) - 3\kappa_4 \chi_3(\beta) + 3\kappa_5 \chi_4(\beta) \right. \\ & \left. + 3\kappa_3 \tau_2 \chi_5(\beta) + 3\kappa_2 \tau_3 \chi_6(\beta) + 3\kappa_6 \chi_7(\beta) \right\} \|u_n - u_m\|. \end{aligned} \quad (4.10)$$

where $\chi_1, \chi_2, \chi_3, \chi_4, \chi_5, \chi_6$ and χ_7 are functions from $L^{-1} \left[\left(\frac{s + \beta(1-s)}{s} \right) L \right]$.

In the same manner, we can get

$$\|\lambda(v_n(t)) - \lambda(v_m(t))\| \leq -(\varrho_4 \varrho_5 \varrho_6) \xi_1(\beta) + 3\kappa_1 \tau_2 \xi_2(\beta) + 3\kappa_7 \xi_3(\beta) \|v_n - v_m\| \quad (4.11)$$

$$\|\lambda(w_n(t)) - \lambda(w_m(t))\| \leq -(\varrho_7 \varrho_8 \varrho_9) \pi_1(\beta) + 3\kappa_1 \tau_3 \pi_2(\beta) + 3\kappa_8 \pi_3(\beta) \|w_n - w_m\|. \quad (4.12)$$

Therefore, from (4.1) nonlinear self mapping λ has a fixed point. Next we show that, λ satisfies all the conditions in Theorem 4.1. Let (4.10) to (4.12) hold and therefore using

$$\psi = (0, 0, 0), \quad \phi = \begin{cases} \left\{ \frac{1}{2} \varrho_1 \varrho_2 \varrho_3 \chi_1(\beta) - 3\kappa_1 \tau_1 \chi_2(\beta) - 3\kappa_4 \chi_3(\beta) + 3\kappa_5 \chi_4(\beta) \right. \\ \quad \left. + 3\kappa_3 \tau_2 \chi_5(\beta) + 3\kappa_2 \tau_3 \chi_6(\beta) + 3\kappa_6 \chi_7(\beta) \right\} < 1, \\ -(\varrho_4 \varrho_5 \varrho_6) \xi_1(\beta) + 3\kappa_1 \tau_2 \xi_2(\beta) + 3\kappa_7 \xi_3(\beta) < 1, \\ -(\varrho_7 \varrho_8 \varrho_9) \pi_1(\beta) + 3\kappa_1 \tau_3 \pi_2(\beta) + 3\kappa_8 \pi_3(\beta) < 1, \end{cases}$$

Thus all the conditions in Theorem 4.2 are satisfied by λ . Therefore, λ is Picard λ -stable.

5 Numerical Application

To illustrate the applicability of method discussed in section 3, we consider the generalized time fractional Hirota-Satsuma coupled KdV equation.

5.1 Solution of the time fractional Hirota–Satsuma coupled KdV equation

The exact solution of Eq.1.1 with initial condition Eq.1.2 when $c = -\gamma$ and $\beta = 1$ is given as

$$\left\{ \begin{array}{l} u(x, t) = \frac{\gamma - 2k^2}{3} + 2k^2 \tanh^2(k(x - ct)) \\ v(x, t) = -\frac{4m^2 \sigma(\gamma + m^2)}{3c_1^2} + \frac{4m^2(\gamma + m^2) \tanh(m(x - ct))}{3\tau} \\ w(x, t) = \sigma + \tau \tanh(m(x - ct)) \end{array} \right. \quad (5.1)$$

Now taking series solution as $u(x, T) = \sum_{i=0}^{\infty} u_i(x, T)$, $v(x, T) = \sum_{i=0}^{\infty} v_i(x, T)$ and $w(x, T) = \sum_{i=0}^{\infty} w_i(x, T)$ then employing recursive relation appropriately with initial condition Eq.1.2 we get an approximate solution as

$$\left\{ \begin{array}{l} u_0 = \frac{1}{3}(\gamma - 2m^2) + \frac{2m^2(e^{2mx} - 1)^2}{(e^{2mx} + 1)^2} \\ v_0 = \frac{4m^2(\gamma + m^2)(e^{2mx} - 1)}{3\tau(e^{2mx} + 1)} - \frac{4m^2\sigma(\gamma + m^2)}{3\tau^2} \\ w_0 = \frac{\tau(e^{2mx} - 1)}{e^{2mx} + 1} + \sigma \end{array} \right. \quad (5.2)$$

$$\left\{ \begin{array}{l} u_1 = \frac{16\gamma m^3 e^{2mx} (e^{2mx} - 1)(\beta(t - 1) + 1)}{(e^{2mx} + 1)^3} \\ v_1 = \frac{16\gamma m^3 (\gamma + m^2) e^{2mx} (\beta(t - 1) + 1)}{3\tau (e^{2mx} + 1)^2} \\ w_1 = \frac{4\gamma m \tau e^{2mx} (\beta(t - 1) + 1)}{(e^{2mx} + 1)^2} \end{array} \right. \quad (5.3)$$

$$u_2 = \frac{1024\beta^3\gamma^2 m^5 t^3 e^{7mx} \sinh(mx) (-\gamma + (5m^2 - \gamma) \cosh(2mx) - 13m^2)}{3(e^{2mx} + 1)^7} - \frac{1}{3(e^{2mx} + 1)^7} \\ - \frac{1}{3(e^{2mx} + 1)^7} 64e^{7mx} m^4 \gamma^2 (-24\beta^2 \cosh(mx) + 48\beta \cosh(mx) - 24 \cosh(mx)) + \dots$$

$$\begin{aligned}
v_2 = & -\frac{1}{3\tau(e^{2mx} + 1)^6} 16e^{2mx}e^{2mx} - 1m^4\gamma^2\gamma + m^2(2 - 4\beta + 2e^{3mx}(3(\beta^2((t-4)t + 2) \\
& + 4\beta(t-1) + 2) \cosh(mx))) + (2(\beta-1)\beta + \beta t(\beta(t-4) + 4) + 1) \cosh(3mx) \\
& + 32m^3(3 + \beta(9\beta + 6\beta(t-3)t + 9(t-1) + \beta^2 + ((t-3)^2t - 3))) \sinh(mx) \\
& + (1 - 2\beta) \sinh(3mx))) + \dots \\
w_2 = & -\frac{1}{(e^{2mx} + 1)^6} 4e^{2mx}m(-8\gamma m^3 - \beta^2\gamma m(t^2 - 4t + 2)(\gamma + 4m^2 - 1) - 2\gamma^2m + 2\gamma m + 1) \cdot \\
& \beta(-(t-1))(16\gamma m^3 + 4(\gamma-1)\gamma m - 1) + e^{8mx}(8\gamma m^3 + \beta^2\gamma m(t^2 - 4t + 2)(\gamma + 4m^2 - 1)) + \dots
\end{aligned}$$

Successively applying the algorithm given in Eq.(3.11), initial few terms of $u(x, t)$, $v(x, t)$ and $w(x, t)$ can be obtained from software package Mathematica. The approximate solution in series form is given as

$$\begin{cases}
u(x, t) = u_0(x, t) + u_1(x, t) + u_2(x, t) \\
v(x, t) = v_0(x, t) + v_1(x, t) + v_2(x, t) \\
w(x, t) = w_0(x, t) + w_1(x, t) + w_2(x, t)
\end{cases} \quad (5.4)$$

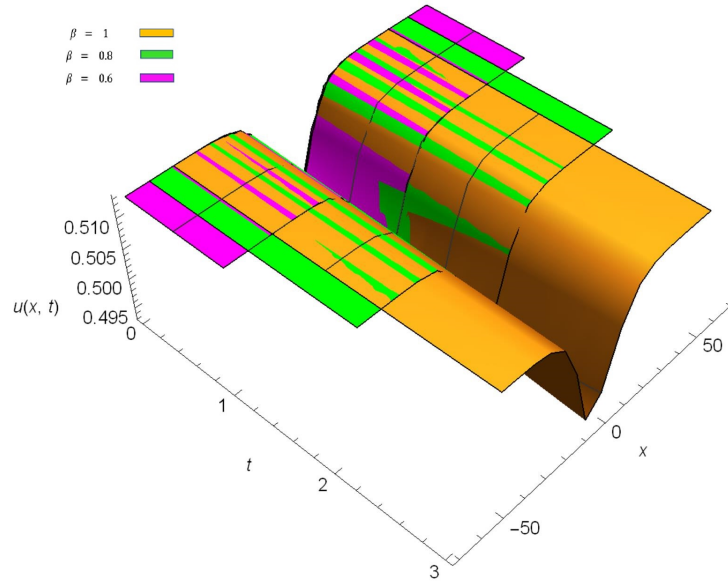

Figure 1: Surface Plot of $u(x, t)$ for $m = 0.1$, $\gamma = 1.5$ and various values of $\beta = 0.6, 0.8, 1$ with respect to t .

The numerical values in Tables 1, 2 and 3 shows the comparison between approximate solutions of Eq.1.1 obtained by using the Caputo-Fabrizio derivative operator

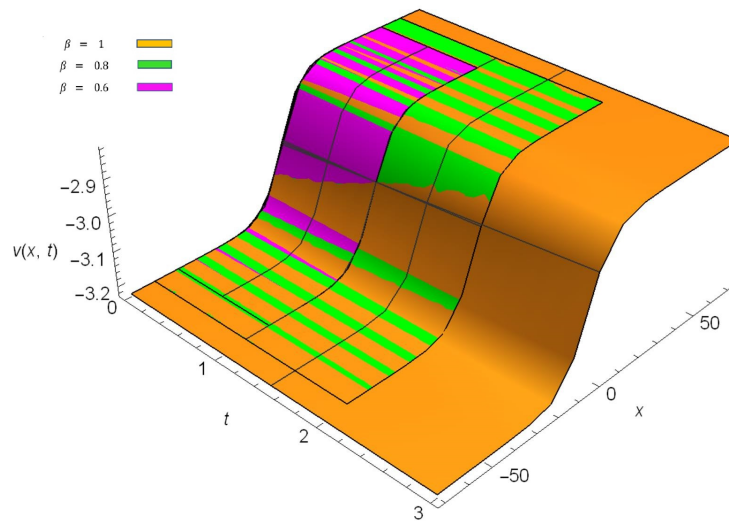

Figure 2: Surface Plot of $v(x, t)$ for $m = 0.1$, $\gamma = 1.5$ and various values of $\beta = 0.6, 0.8, 1$ with respect to t .

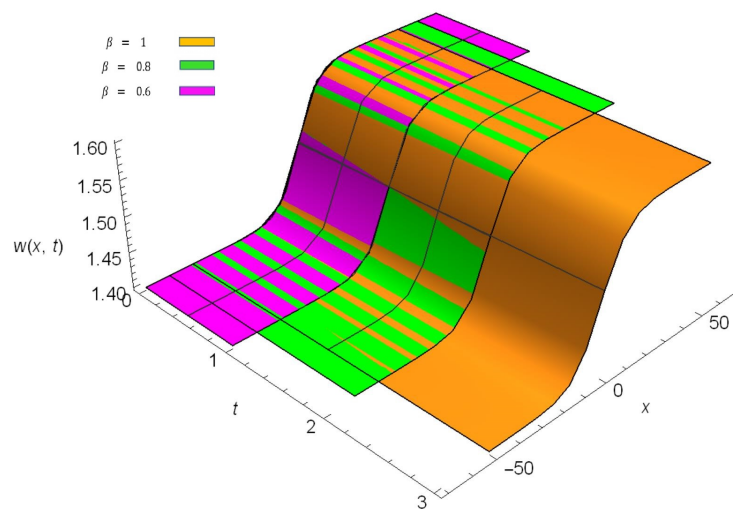

Figure 3: Surface Plot of $w(x, t)$ for $m = 0.1$, $\gamma = 1.5$ and various values of $\beta = 0.6, 0.8, 1$ with respect to t .

and Caputo operator for different values of β . We substitute $\beta = 1$, $\gamma = 1.5$, $m = 0.1$, $\sigma = 1.5$ and $\tau = 0.1$ in approximate solution and take three terms of all series. Also numerical values of solution is evaluated for $\beta = 0.6$, and 0.8 . From these results it has been observed that the obtained approximate series solutions are in good agreement with the exact solutions. It is also noted that Caputo-Fabrizio fractional derivative demonstrates new nature compared with the Caputo fractional derivative.

Fig. 1, 2 and 3 shows the surfaces of approximate solution of Eq.1.1 for $u(x, t)$ which is of bell shaped but kink-type for $v(x, t)$ and $w(x, t)$ when $\beta = 1$, $\gamma = 1.5$, $m = 0.1$,

t	x	Caputo Fabrizio Operator		Caputo Operator		Absolute error
		$\beta = 0.6$	$\beta = 0.8$	$\beta = 0.6$	$\beta = 0.8$	$ u_{exact} - u_{approx} $ for $\alpha = 1$
0.25	0	0.493595	0.493459	0.493440	0.493390	2.63462×10^{-8}
	0.2	0.493667	0.493515	0.493506	0.493490	2.46812×10^{-8}
	0.4	0.493754	0.493585	0.493587	0.493506	2.27884×10^{-9}
	0.6	0.493855	0.493671	0.493684	0.493587	2.06216×10^{-8}
	0.8	0.493971	0.493772	0.493795	0.493684	1.81381×10^{-8}
	1	0.494101	0.493887	0.493921	0.493887	1.52997×10^{-8}
0.50	0	0.493734	0.493585	0.493579	0.493504	4.20534×10^{-7}
	0.2	0.493822	0.493663	0.493673	0.493585	4.04902×10^{-7}
	0.4	0.493924	0.493756	0.493783	0.493681	3.86055×10^{-7}
	0.6	0.494041	0.493864	0.493907	0.493792	3.63665×10^{-7}
	0.8	0.494172	0.493986	0.494045	0.493918	3.37452×10^{-7}
	1	0.494316	0.494198	0.494198	0.494057	3.07179×10^{-7}
0.75	0	0.493892	0.493747	0.493732	0.493661	2.12053×10^{-6}
	0.2	0.493996	0.493847	0.493850	0.493768	2.05647×10^{-6}
	0.4	0.494114	0.493962	0.493981	0.493890	1.97697×10^{-6}
	0.6	0.494245	0.494090	0.494127	0.494027	1.88113×10^{-6}
	0.8	0.494390	0.494232	0.494286	0.494177	1.76820×10^{-6}
	1	0.494547	0.494387	0.494458	0.494440	1.63769×10^{-6}

Table 1: Table of comparison for approximate solution of $u(x,t)$ between Caputo fractional derivatives and Caputo-Fabrizio fractional derivative and also absolute errors for difference between exact and approximate solution for $\beta = 0.6, 0.8$

$\sigma = 1.5$ and $\tau = 0.1$ respectively. It is observed that all the curves of approximate solution are exactly similar with the curves of exact solutions [11]. All Figures and Tables 1 to 2 shows that there is a remarkable difference at various estimations of β and this model depend continuously on the time fractional derivative.

t	x	Caputo Fabrizio Operator		Caputo Operator		Absolute error for $\alpha = 1$
		$\beta = 0.6$	$\beta = 0.8$	$\beta = 0.6$	$\beta = 0.8$	
0.25	0	-3.00339	-3.00792	-3.00529	-3.00930	3.53707×10^{-6}
	0.2	-2.99942	-3.00392	-3.00129	-3.00529	3.52590×10^{-6}
	0.4	-2.99547	-2.99994	-2.99731	-3.00129	3.50304×10^{-6}
	0.6	-2.99154	-2.98810	-2.99334	-2.99731	3.46866×10^{-6}
	0.8	-2.98763	-2.99203	-2.98939	-2.99334	3.42300×10^{-6}
	1	-2.98375	-2.98810	-2.98547	-2.98940	3.36637×10^{-6}
0.50	0	-2.99886	-3.00188	-2.99770	-3.00138	2.82489×10^{-5}
	0.2	-2.99492	-2.99791	-2.99373	-2.99739	2.81175×10^{-5}
	0.4	-2.99101	-2.99396	-2.98979	-2.99343	2.78932×10^{-5}
	0.6	-2.98711	-2.99003	-2.98586	-2.98948	2.75777×10^{-5}
	0.8	-2.98324	-2.98612	-2.98197	-2.98556	2.27173×10^{-5}
	1	-2.97940	-2.98224	-2.97810	-2.98224	2.66819×10^{-5}
0.75	0	-2.99433	-2.99584	-2.99156	-2.99424	9.50734×10^{-5}
	0.2	-2.99043	-2.99191	-2.98762	-2.99029	9.44897×10^{-5}
	0.4	-2.98655	-2.98800	-2.98372	-2.98636	9.35954×10^{-5}
	0.6	-2.98269	-2.98411	-2.97984	-2.98246	9.23966×10^{-5}
	0.8	-2.97887	-2.98025	-2.97599	-2.97859	9.09015×10^{-5}
	1	-2.97507	-2.97643	-2.97217	-2.97476	8.91209×10^{-5}

Table 2: Table of comparison for approximate solution of $v(x,t)$ between Caputo fractional derivatives and Caputo-Fabrizio fractional derivative and also absolute errors for difference between exact and approximate solution for $\beta = 0.6, 0.8$

6 Conclusions:

In this study, we have investigated Caputo-Fabrizio fractional order time fractional generalized Hirota-Satsuma coupled KdV system by using iterative Laplace transform method. Further, by applying Banach theorem, the existence and stability results for steady solutions have been proved. The series solutions obtained by this powerful approach demonstrate a decent consent. It is obvious that the effectiveness of this technique can be drastically enhanced by reducing steps and computing more components. Also Caputo-Fabrizio fractional operator and the methodology presented in this work shall be appropriate for modeling other real world problems.

Acknowledgement

All authors are grateful to the anonymous referees for their valuable suggestions and comments and also declare that there is no conflict of interests regarding the publication of this paper.

t	x	Caputo Fabrizio Operator		Caputo Operator		Absolute error for $\alpha = 1$
		$\beta = 0.6$	$\beta = 0.8$	$\beta = 0.6$	$\beta = 0.8$	
0.25	0	1.50275	1.50200	1.50731	1.50531	2.4980×10^{-3}
	0.2	1.50474	1.50400	1.50929	1.50730	2.4950×10^{-3}
	0.4	1.50673	1.50599	1.51127	1.50929	2.4900×10^{-3}
	0.6	1.50871	1.50798	1.51324	1.51127	2.4830×10^{-3}
	0.8	1.51069	1.50996	1.51320	1.51324	2.4740×10^{-3}
	1	1.51265	1.51193	1.51715	1.51520	2.4640×10^{-3}
0.50	0	1.50350	1.50300	1.51108	1.50925	4.9850×10^{-3}
	0.2	1.50549	1.50499	1.51305	1.51123	4.9750×10^{-3}
	0.4	1.50747	1.50698	1.51501	1.51320	4.9610×10^{-3}
	0.6	1.50945	1.50896	1.51696	1.51516	4.9440×10^{-3}
	0.8	1.51142	1.51094	1.51889	1.51711	4.9220×10^{-3}
	1	1.51338	1.51290	1.52081	1.51904	4.8970×10^{-3}
0.75	0	1.50425	1.50400	1.51413	1.51279	7.4520×10^{-3}
	0.2	1.50623	1.50599	1.51608	1.51476	7.4319×10^{-3}
	0.4	1.50821	1.50797	1.51802	1.51671	7.4052×10^{-3}
	0.6	1.51018	1.50994	1.51995	1.51864	7.3727×10^{-3}
	0.8	1.51214	1.51191	1.52186	1.52057	7.3340×10^{-3}
	1	1.51410	1.51387	1.52376	1.52247	7.2914×10^{-3}

Table 3: Table of comparison for approximate solution of $w(x,t)$ between Caputo fractional derivatives and Caputo-Fabrizio fractional derivative and also absolute errors for difference between exact and approximate solution for $\beta = 0.6, 0.8$

References

- [1] A. Abdon and B. Dumitru, New fractional derivatives with nonlocal and non-singular kernel, Theory and application to heat transfer model, Therm. Sci. 20(2016), 763-769.
- [2] G. Adomian and R. Rach, Modified Adomian polynomials, Mathematical and computer modelling. 24(11)(1996), 39-46.
- [3] D. Baleanu, G..C. Wu , S..D. Zeng, Chaos analysis and asymptotic stability of generalized Caputo fractional differential equations, Chaos Solitons Fractals. 102 (2017), 99–105.
- [4] D. Baleanu, Z.B. Guvenc, J.A. Tenreiro Machado, New Trends in Nanotechnology and Fractional Calculus Applications, Springer Dordrecht Heidelberg, London New York, 2010.

- [5] D. Baleanu, K. Diethelm, E. Scalas, and J.J. Trujillo, *Fractional Calculus Models and Numerical Methods*, Series on Complexity, Nonlinearity and Chaos. World Scientific, Singapore, 2012.
- [6] T. Bashiri, S.M.Vaezpour and J.J.Nieto, Approximating Solution of Fabrizio-Caputo Volterra's Model for Population Growth in a Closed System by Homotopy Analysis Method, *Journal of Function Spaces*. 2018 (2018), Article ID 3152502, 10 pages.
- [7] V. N. Bhadgaonkar and B. R. Sontakke, Exact Solution of Space-Time Fractional Partial Differential Equations by Adomian Decomposition Method, *Journal of Advances in Mathematics and Computer Science*. 36(6)(2021), 75-87. <https://doi.org/10.9734/jamcs/2021/v36i630373>.
- [8] M. Caputo and M. Fabrizio, A new definition of fractional derivative without singular kernel, *Progress in Fractional Differentiation and Applications*, 1(2)(2015), 73-85.
- [9] D. B. Dhaigude and V. N. Bhadgaonkar, A novel approach for fractional Kawahara and modified Kawahara equations using Atangana-Baleanu derivative operator, *J. Math. Comput. Sci.*, 11 (2021), 2792-2813.
- [10] D. B. Dhaigude and V. N. Bhadgaonkar, An analytical study of reaction diffusion, $(3 + 1)$ -dimensional diffusion equations using Caputo Fabrizio fractional differential operator, *J. Math. Comput. Sci.*, 11 (2021), 183-202.
- [11] E. G. Fan, Soliton solution for a generalized Hirota-Satsuma coupled KdV equation and a coupled MKdV equation, *Physics Letter A*, 282(1-2)(2001), 18-22.
- [12] Z. Z. Ganji, D. D. Ganji and Y. Rostamiyan, Solitary wave solutions for a time-fraction generalized Hirota-Satsuma coupled KdV equation by an analytical technique, *Applied Mathematical Modelling*, 33(2009), 3107-3113.
- [13] J. H. He, Variational iteration method a kind of non-linear analytical technique some examples, *International Journal of Nonlinear Mechanics*, 34(4)(1999), 699-708.
- [14] A.A. Hemeda, Homotopy perturbation method for solving systems of nonlinear coupled equations. *Appl. Math. Sci.* 6(96)(2012), 4787-4800.
- [15] R. Hilfer, Y. Luchko and U. Tomovski, Operational method for the solution of fractional differential equations with generalized Riemann-Liouville fractional derivatives. *Fract. Calc. Appl. Anal.* 12(2009), 299-318.
- [16] H. Hu, L. Liu, and L. Zhang, New analytical positon, negaton and complexiton solutions of a coupled KdV-mKdV system, *Applied Mathematics and Computation*, 219(2013), 5743-5749.

- [17] U.N. Katugampola, A new approach to generalized fractional derivatives. *Bull. Math. Anal. Appl.* 6(2014), 1-15.
- [18] N.A. Khan, S. Rasheed, Analytical solutions of linear and nonlinear Klein-Fock-Gordon equation, *Nonlinear Eng.* 4 (1) (2015), 43-48.
- [19] M. M.A. Khater, E. H.M. Zahran and M. S.M. Shehata, Solitary wave solution of the generalized Hirota-Satsuma coupled KdV system, *Journal of the Egyptian Mathematical Society*, 25(1)2017, 8-12, <https://doi.org/10.1016/j.joems.2016.04.006>.
- [20] V. Lakshmikantham, S. Leela and J. Vasundhara, *Theory of fractional dynamic systems*, Cambridge Academic Publishers, Cambridge, 2009.
- [21] S. J. Liao, On the homotopy analysis method for nonlinear problems, *Applied Mathematics and Computation*, 147(2004), 499-513.
- [22] M. Mehmet, G. Ahmet, Yildirim and M., Syed, Solution of time-fractional generalized Hirota-Satsuma coupled KdV equation by generalised differential transformation method. *International Journal of Numerical Methods for Heat and Fluid Flow*. 23(2013). 10.1108/HFF-09-2011-0188.
- [23] K.S. Miller and B. Ross, *An Introduction to the Fractional Calculus and Fractional, Differential Equations*. Willey, New York, 1993.
- [24] K. B. Oldham and J. Spanier, *Fractional Calculus*, Academic Press, New York, NY, USA, 1974.
- [25] I. Podlubny, *Fractional Differential Equations*. Academic Press, San Diego, 1999.
- [26] K. R. Raslan, The decomposition method for a soliton solution for a Hirota-Satsuma coupled KdV equation and a coupled MKdV equation, *International Journal of Computer Mathematics*, 18(4)(2004), 1497-1505.
- [27] A.S.V. Ravi Kanth and K. Aruna, Differential transform method for solving the linear and nonlinear Klein-Gordon equation, *Comput. Phys. Commun.* 180 (2009), 708-711.
- [28] A. S. Shaikh and K. S. Nisar, Transmission dynamics of fractional order Typhoid fever model using Caputo-Fabrizio operator, *Chaos, Solitons and Fractals*. 128 (2019), 355-365.
- [29] A. Shaikh, A. Tassaddiq, K.S. Nisar and D. Baleanu. Analysis of differential equations involving Caputo-Fabrizio fractional operator and its applications to reaction-diffusion equations. *Advances in Difference Equations*. 178(2019), 2019, <https://doi.org/10.1186/s13662-019-2115-3>.

- [30] M. Shateri, D. D. Ganji, Solitary Wave Solutions for a Time-Fraction Generalized Hirota-Satsuma Coupled KdV Equation by a New Analytical Technique, *International Journal of Differential Equations*, vol. 2010, Article ID 954674, 11 pages, 2010. <https://doi.org/10.1155/2010/954674>.
- [31] B. R. Sontakke and A. Shaikh, Solving time fractional Sharma–Tasso–Oleiver equation using fractional complex transform with iterative method, *British Journal of Mathematics and Computer Science*, 19(1)(2016), 1-10.
- [32] B. R. Sontakke and A. Shaikh, Approximate solutions of time fractional Kawahara and modified Kawahara equations by fractional complex transform. *Communications in numerical analysis*, 2(2)(2016), 218-229.
- [33] B. R. Sontakke, and S. R. Raut, Analysis of Fractional Kawahara and Modified Kawahara equations based on Caputo-Fabrizio derivative operator, *J. Math. Comput. Sci.* 11 (6)(2021), 7105-7125.
- [34] B.R. Sontakke, A. Shaikh and K.S. Nisar, Approximate Solutions of a Generalized Hirota-Satsuma Coupled KdV and a Coupled mKdV Systems with Time Fractional Derivatives, *Malaysian Journal of Mathematical Sciences*, 12(2)(2018), 175-196.
- [35] N.H. Sweilam, M.M.A. Hasan and D. Baleanu, New studies for general fractional financial models of awareness and trial advertising decisions, *Chaos Solitons Fractals*. 104 (2017), 772-784.
- [36] K. C. Takale, Fractional order Finite difference scheme for space fractional Boussinesq's equation and its application, *International Journal of Mathematical Sciences and Applications*, 3(1)(2013), 343-353.
- [37] P. Veerasha, D.G. Prakasha, D. Kumar, D. Baleanu and J. Singh, An Efficient Computational Technique for Fractional Model of Generalized Hirota–Satsuma-Coupled Korteweg–de Vries and Coupled Modified Korteweg–de Vries Equations, *ASME. J. Comput. Nonlinear Dynam.* 15(7)(2020), 071003. <https://doi.org/10.1115/1.4046898>.
- [38] Y. T. Wu, X. G. Geng, X. B. Hu and S. M. Zhu, A generalized Hirota–Satsuma coupled Korteweg-de Vries equation and Miura transformation, *Physics Letter A*, 255 (4-6) (1999), 259-264.
- [39] B. Zheng, (G0/G)-expansion method for solving fractional partial differential equations in the theory of mathematical physics, *Communications in Theoretical Physics*, 58(2012), 623-630.