

Exploring Fundamentals: Theory of Machines and Mechanism Inversions

Mr. Sandeep Kumar, PhD Scholar,
Department of Mechanical Engineering,
Indian Institute of Technology, Ropar,
Punjab, India – 140001
Email: sandeep.22mez0005@iitrpr.ac.in,
sandeep6437@gmail.com

Dr. Prabir Sarkar, Associate Professor,
Department of Mechanical Engineering,
Indian Institute of Technology, Ropar,
Punjab, India – 140001
Email: prabir@iitrpr.ac.in

ABSTRACT

The kingdom of Mechanical Engineering is closely knotted with the principles governing motion, transformation, and the complex interactions within machines and mechanisms. This chapter explores the foundational aspects of "Theory of Machines and Mechanism Inversions." Theory of Machines forms the foundation of Mechanical Engineering, encompassing dynamics, kinematics, and mechanism classifications. This chapter explores into its core, highlighting mobility, degrees of freedom, and linkage between mechanisms and functions. Mechanism Inversions, a captivating concept, involves reconfiguring components to achieve diverse functionalities. Here, we are examining kinematic inversions in planar and spatial mechanisms, showcasing their adaptability in domains like robotics and automotive engineering. By altering arrangements, engineers can innovate and tailor designs to specific needs. In conclusion, this research offers insights into the fundamental "Theory of Machines and Mechanism Inversions." By elucidating these concepts, it paves the way for innovative mechanical engineering solutions, underpinning how engineers analyze, optimize, and conceptualize mechanical systems.

Keywords—Mechanisms; Degree of Freedom; Kinematic Pairs; Joints, Inversion of Mechanism

I. INTRODUCTION

Kinematics and dynamics come under mechanics in which we study the motion of rigid bodies under the action of external forces without and with the consideration of external forces respectively, which affects the motion of rigid bodies. Mechanics is a very vast field in Engineering, where we study the equilibrium of bodies which may be at rest and in motion. In Mechanics, we study solid, liquid and gases bodies. As we all know that in Fluid Mechanics, we study the behavior of liquids and gases and in strength of Materials/Mechanics of Solids, we study the behavior of solid bodies.

Throughout history, machines have played a vital role in shaping human civilization, revolutionizing productivity, and propelling technological advancements. From the intricate clockwork mechanisms of ancient times to the cutting-edge robotics of today, the study of machines and their components is of paramount importance. This leads us to the fascinating domains of "Kinematics and Dynamics of Machines."

Kinematics is the branch of study that explores into the analysis of motion, focusing on describing the positions, velocities, and accelerations of various machine parts without considering the forces that cause this motion. It serves as the fundamental framework for understanding the mechanisms governing the movement of mechanical systems. Engineers and researchers utilize kinematics to gain insights into machine operations, optimize performance, and design innovative devices with enhanced efficiency and precision.

Dynamics of Machines complements kinematics by examining the forces and torques that act on machines and their components, and how these forces influence their motion. This branch of study enables engineers to comprehend the forces involved in machine operation, how they impact overall performance and structural integrity, and how to address potential issues such as vibration, stress, and instability through design improvements.

The integration of kinematics and dynamics is pivotal in various fields, including mechanical engineering, robotics, the automotive industry, and more. This fusion of motion and forces allows experts to develop cutting-edge technologies, refine existing machines, and ensure the safety and reliability of diverse mechanical systems. Over time, researchers and engineers have harnessed mathematical tools, computational methods, and sophisticated simulations to model and predict machine behavior under different conditions. This has pushed the boundaries of machine capabilities, enabled groundbreaking innovations and fostering a world of ever-evolving possibilities. As we embark on an exploration of Kinematics and Dynamics of Machines, we will uncover the fundamental principles and applications that underpin the design and functionality of the machines that surround us. Whether you are an aspiring engineer, a seasoned researcher, or simply curious about the mechanics that drive the world, this journey promises to be an enlightening and inspiring one.

In this chapter you will learn about the basics of machines and mechanisms and inversions of four bar mechanism in detail.

II. IMPORTANT TERMS

All students must have a clear understanding about the terms used in kinematics and dynamics of machines which are listed below:

- 1. Mechanism:** Mechanism is combination of different rigid links, which are interconnected and have relative motion between them. In mechanisms, motion of one-link causes constrained and expected motions to other.
Condition and function of a mechanism: The condition for mechanism is that one link should always be fixed. If no link is fixed in any mechanism, then we cannot call it as a mechanism. The function of the mechanism is to transfer and modify a motion from one link to the other link only.
- 2. Machine:** Machine means which converts the available mechanical energy into a useful work.

There is difference between machine and mechanism which must be very clear to the students that mechanism only transfer motion to the other links but machine convert that available motion into a desired work.

3. **Rigid Body:** A rigid body is that which does not distort/disfigure after we apply load on it. In simple words we can define rigid body as that body in which the distance between two points does not change after we apply the load it.
4. **Resistant Body:** Resistant bodies are those bodies, which become rigid after certain extreme limits. Belts and fluids are the best examples of resistant bodies, which become rigid after applying tensile and compressive forces in them respectively. Initially these bodies are not rigid but after certain limit they become rigid.
5. **Kinematic Pairs:** Kinematic pair is a joint between two kinematic links having relative motion between them. It must be noted here that if any joint has no relative motion between the links, then it can not be called as a kinematic pair.
6. **Kinematic Link:** Kinematic link is a rigid body whose connections are rigid and it does not allow relative motion between its connections. Kinematic link may also be defined as a rigid body, which connects other rigid body and have relative motion between those two bodies.

Kinematic links are of different types depend upon its end shape and number of nodes as shown in figures.

- i. **Binary Link:** Which consist of 2 nodes
- ii. **Ternary Link:** Which consist of 3 nodes
- iii. **Quaternary Link:** Which consist of 4 nodes
- iv. **Other Link:** Which consist of more than 4 nodes

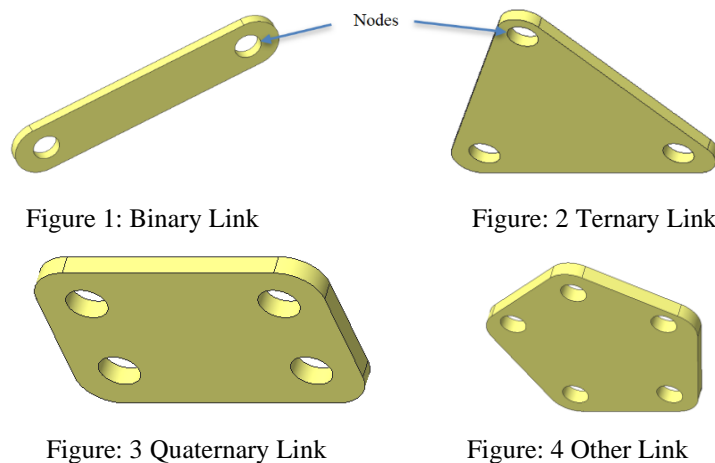

Figure 1: Binary Link

Figure: 2 Ternary Link

Figure: 3 Quaternary Link

Figure: 4 Other Link

7. **Kinematic Chain:** In a mechanism, when number of links are connected in such a way that last link is connected with the first link is said to be a kinematic chain. The motion of a kinematic chain is definite with respect to the other link.

Types of Joints

The number of joints in any kinematic chain are as follows:

- i. Binary Joint
- ii. Ternary Joint
- iii. Quaternary Joint
- iv. Other Joint

Binary Joint: If two links are connected by same connection at their joint, then it is said to a binary joint as shown in Figure: 5

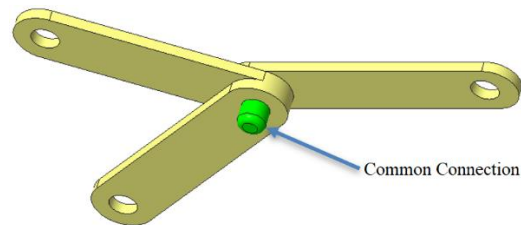

Figure: 5 Binary Joint

Ternary Joint: If three links are connected by same connection at their joint, then it is said to be a ternary joint. Ternary joint is considered equal to two binary joints because fixing of one link constitute two binary joints with each of the other two links.

Quaternary Joint: If four links are connected by same connection at their joint, then it is said to a quaternary joint. It is equal to three binary joints.

Classification of Kinematic Pairs: Kinematic pairs are classified based on their nature of contact, mechanical control and relative movement between two bodies.

1. Based upon their nature of contact: Kinematic pairs based on their nature of contact between two bodies are:

- i. Lower Pair
- ii. Higher Pair
- iii. Wrapping Pair

- i. **Lower Pair:** When two bodies are connected with each other having surface or area contact between them, then they constitute a lower pair. For example, bearing rotating over shaft, Book resting on a table.

Note: The contacting surfaces must be similar.

- ii. **Higher Pair:** When two bodies are connected with each other having point and line contact between them, then they constitute a higher pair. For example CAM & Follower, writing with a pen on a copy.
- iii. **Wrapping Pair:** When two bodies are completely wrap with each other, then they constitute a wrapping pair. For example belt & pulleys, chain and sprocket.

2. Based upon mechanical control: Kinematic pairs based on mechanical control are:

- i. **Form Closed Pair**
 - ii. **Forced Closed Pair**
- I. **Form Closed Pair:** When the contact between the two bodies/elements is maintained by their geometric shape and by the action of gravity, then they constitute a form-closed pair. It is also called as self closed pair or unclosed pair. For example meshing of gears, nut and screw etc.
 - II. **Forced Closed Pair:** When some external mechanical forces maintain the contact between the two bodies, then they constitute a force-closed pair. For example CAM & Follower with spring.

3. Based upon relative movement (motion): Kinematic pairs based on relative movement (motion) are:

- i. **Revolute Pair/Turning Pair**
- ii. **Prismatic Pair/Sliding Pair**
- iii. **Cylindrical Pair**
- iv. **Screw Pair**
- v. **Spherical Pair**
- vi. **Planar Pair**

- I. **Revolute Pair/Turning Pair:** It is represented by R-pair in short. When there is a pure relative rotation/revolution between the two bodies, then they will constitute a revolute/turning pair, when one of the body/element is fixed in between them.
Examples: Hinge joint, A circular shaft rotating in bearing with collars etc.
- II. **Prismatic Pair/Sliding Pair:** It is represented by P-pair in short. When there is a pure relative translation/sliding between the two bodies, then they will constitute a prismatic/sliding pair, when one of the body/element is fixed in between them.
Examples: Piston in a cylinder, A rectangular/square shaft sliding in rectangular/square hole etc.
- III. **Cylindrical Pair:** It is represented by C-pair in short. When there is a relative rotation/revolution and translation/sliding also in a kinematic pair, then they will constitute a cylindrical pair. Here both the motions are independent and will not affect each other.
Examples: A circular shaft rotating in bearing without collars etc.
- IV. **Screw Pair:** It is represented by H-pair in short. Here 'H' stands for helix/helical threads. When there is a relative rotation/revolution and translation/sliding also in a kinematic pair, then they will constitute a screw

pair. Here both the motions are dependent on each other i.e., without rotation there will be no translation and vice versa.

Examples: Nut and screw/bolt.

V. Spherical Pair: It is represented by G-pair in short. Here ‘G’ stands for Globe i.e., sphere itself. When there is a relative rotation/revolution between the two bodies in all three mutually perpendicular axis without any translation, then they will constitute a spherical pair, when one of the body/element is fixed in between them.

Examples: Ball in Ball pens, Ball and socket joint etc.

VI. Planar Pair: It is represented by E-pair in short. ‘E’ stand for ‘Ebanay’ a German word. When a body is placed in a plane say on a table and has translational motion in two perpendicular axis along with rotational motion along third perpendicular axis. It is said to be planar pair. Here all these three motions are independent.

Table 1: Kinematic Pairs based on Relative Motion

S. No.	Pair	Representation	Degree of Freedom	No. of Independent Coordinates	Pair
1	Revolute/Turning Pair	R-Pair	1	θ	Revolute/Turning Pair
2	Sliding/Prismatic Pair	P-Pair	1	T	Sliding/Prismatic Pair
3	Cylindrical Pair	C-Pair	2	θ, T	Cylindrical Pair
4	Screw Pair	H-Pair	1	θ/T	Screw Pair
5	Spherical Pair	G-Pair	3	$\theta_x, \theta_y, \theta_z$	Spherical Pair
6	Planar Pair	E-Pair	3	T_x, T_y, θ_z	Planar Pair
7	Higher Pair	PL-Pair	2	T_x, θ_z	Higher Pair

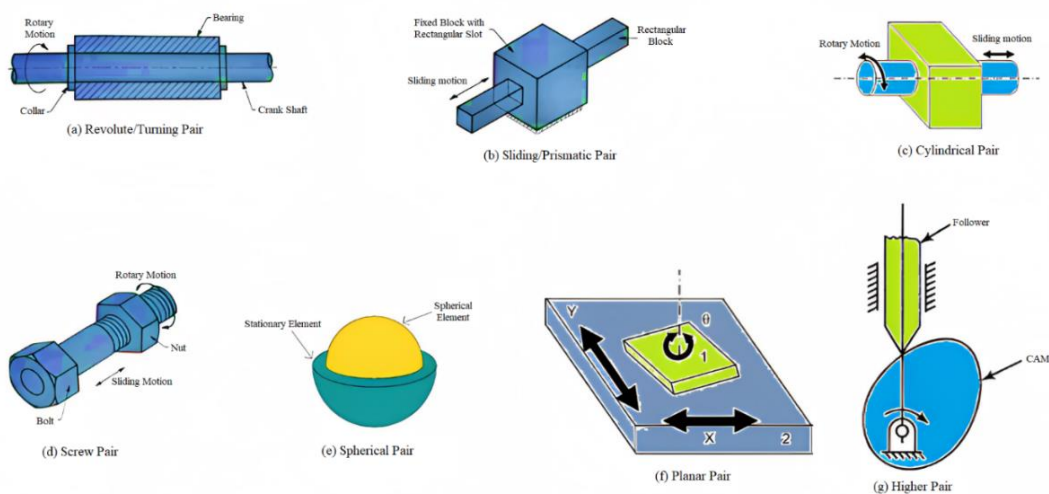

Figure: 6 Kinematic Pairs based on Relative Motion

III. CONSTRAINED MOTION AND ITS TYPES

Definition of Constrained Motion: In a kinematic pair, if one element/link has got only one definite motion relative to the other element/link, then such type of motion is called as constrained motion. It means that constrained motion has only 1 DOF.

There are three types of constrained motions as mentioned below.

1. Completely Constrained Motion
2. Incompletely Constrained Motion
3. Successfully/Partially Constrained Motion

1. Completely Constrained Motion:- In a kinematic pair, a motion is said to a completely constrained motion, if it is in a definite direction irrespective of the direction of the force applied.

For Example: Rectangular bar in a rectangular hole, turning pair/revolute pair, prismatic pair all are examples of completely constrained motion.

2. Incompletely Constrained Motion:- In a kinematic pair, a motion is said to a incompletely constrained motion, if it is possible in two directions but depends upon the direction of the force applied.

Note: It is undesirable for any mechanical system as it leads to inappropriate/improper mechanical output.

For Example: A cylindrical rod in a circular hole, cylindrical pair all are examples of incompletely constrained motion.

3. Successfully/Partially Constrained Motion: - In a kinematic pair, a motion is said to a successfully/partially constrained motion, if it is possible in two directions initially but it is made to have only in one direction by using some external force.

For Example: Foot step bearing

IV. DEGREE OF FREEDOM (DOF) FOR PLANE MECHANISMS WITH GRUBLER'S/KUTZBACK'S CRITERION AND BY LOOP

For a body which is not constrained in space have six degree of freedom i.e., three translational motions along X,Y & Z axis and three rotational motions about these three mutually perpendicular axis.

But as we know, in order to achieve a motion in the mechanism, we always have to fix one link so that the relative motion between the interconnected bodies/links is determined with respect to the fix link/body.

Therefore, degree of freedom (DOF) will be $6 - \text{Number of restrictions/restraints}$.

With the help of this, we can easily calculate the degree of freedom for a mechanism in space.

Now as we know that mechanism consists of different number of links say 'N' and 'DOF' is the degree of freedom in it. There are also number of pair/joints in that mechanism which are having one, two, three, four and five degrees of freedom by imposing number of restrictions as five, four, three, two and one respectively and thus by reducing their degree of freedom by $5K_1, 4K_2, 3K_3, 2K_4, 1K_5$. We cannot impose 6 restrictions in it because then it will become a structure not mechanism.

So, the generalized formula for DOF in a space will be:

$$DOF = 6(N - 1) - 5K_1 - 4K_2 - 3K_3 - 2K_4 - 1K_5 \text{ -----(1)}$$

Here, N = Total number of links

(N-1) = No. of Movable links

DOF = Degree of freedom

K_1 = No. of pairs with one degree of freedom

K_2 = No. of pairs with two degrees of freedom

K_3 = No. of pairs with three degrees of freedom

K_4 = No. of pairs with four degrees of freedom

K_5 = No. of pairs with five degrees of freedom

Equation no. 1 used to find the degree of freedom in a space mechanism. But most of the mechanisms which we will study in this course will be plane mechanisms, in which body have three degrees of freedom i.e., two translational motions and one rotational motion about third perpendicular axis.

Therefore, for plane mechanisms by adopting the same fundamentals as we have got DOF equation no. 1 will be:

$$DOF = 3(N - 1) - 2K_1 - 1K_2 \text{ -----(2)}$$

Here, N = Total number of links

(N-1) = No. of Movable links

DOF = Degree of freedom

K_1 = No. of pairs with one degree of freedom

K_2 = No. of pairs with two degrees of freedom

Equation no. 2 is also known as 'Grubler's criterion' to find out the DOF for a plane mechanism. Many authors may also mention this as 'Kutzback's criterion' to find out DOF in a plane mechanism, but there is little difference between their criterions. Kutzback has simplified the equation no. 2 by $DOF = 3(N - 1) - 2K_1$, which is applicable to the mechanisms with a single DOF only. Therefore, for a mechanism with I DOF, $K_2 = 0$.

$$DOF = 3(N - 1) - 2K_1 \text{ -----(3)}$$

So now, it should be very clear that equation no. 2 is known as Grubler's criterion and equation no. 3 is known as Kutzbach's criterion to calculate the DOF for a plane mechanism.

The DOF can also be calculated by loop formula i.e., when the number of links and number of loops are known in a kinematic chain with turning pairs only.

$$DOF = N - (2L + 1) \text{ -----(4)}$$

$$K_1 = N + (L - 1) \text{ -----(5)}$$

- Here, N = Total number of links
 L = No. of loops
 DOF = Degree of freedom
 K₁ = No. of pairs with one degree of freedom

Based on equation no. 4 and 5, the following table may be holds good.

Table 2: Relationship Between DOF and K₁

Loops (L)	DOF	K ₁
1	N-3	N
2	N-5	N+1
3	N-7	N+2
4	N-9	N+3
5	N-11	N+4
6	N-13	N+5
-	-	-
-	-	-
-	-	-

Definition of Degree of Freedom

Degree of freedom may be defined as the independent movement of one body in any direction relative to other body in a kinematic pair. These independent movements are also called as independent coordinates or pair variables which are used to define the relative motion permitted in a kinematic pair.

Four Link Mechanism

Four link mechanism is the most basic mechanism because of its easiness and versatility. It consists of four rigid links which are connected by pin joints. A link which makes complete/full revolution about a fix point relative to other links is known as 'crank' and most of the cases it will be the shortest link. The crank is also called as an input link. The link opposite to the crank/input link is called as the follower/rocker/lever/output link. The link opposite to the fixed link is called as the coupler/connecting rod because it connects the input and output link.

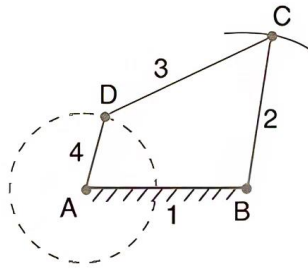

Figure:7 Four Bar Chain

Grashof's Law: This law states that “In a four-bar chain mechanism, the sum of the shortest and longest link length should not be greater than the sum of the remaining two link lengths, if there is to be continuous relative motion between the two links”

OR

We may define this law as “In a four-bar chain mechanism, the sum of the shortest and longest link lengths must be equal or less than the sum of the remaining two link lengths”.

V. INVERSION OF MECHANISM

As we already know that in a kinematic chain, one link should always be fixed only then it is termed as a mechanism (this is a must condition). So, we can obtain number of mechanisms in a kinematic chain by fixing links alternatively one by one. So, this process of obtaining different mechanisms by fixing links one by one in a kinematic chain is known as inversion of mechanism.

Important Note: It must be very clear here that the relative motion between the various links does not change through the process of inversion of mechanisms, but their motions with respect to the fixed link may be changed significantly.

Inversions of Four Bar Chain Mechanism

There are three types of inversion of mechanisms in a four-bar chain mechanism.

- 1) 3R-1P (Single Slider Crank Mechanism)
- 2) 2R-2P (Double Slider Crank Mechanism)
- 3) 4R

3R-1P inversion of mechanisms means in which there are three revolute pairs (3R-Pairs) and one prismatic pair (1P- Pair) in a four-bar chain mechanism. Similarly, 2R-2P inversion of mechanisms means in which there are two revolute pairs (2R-Pairs) and two prismatic pairs (2P- Pair) in a four-bar chain mechanism. 4R mechanisms means in which all joint has revolute pairs in a four-bar chain mechanism. Figure shows the complete inversions of four bar chain mechanism with their applications. We will study all these mechanisms one by one.

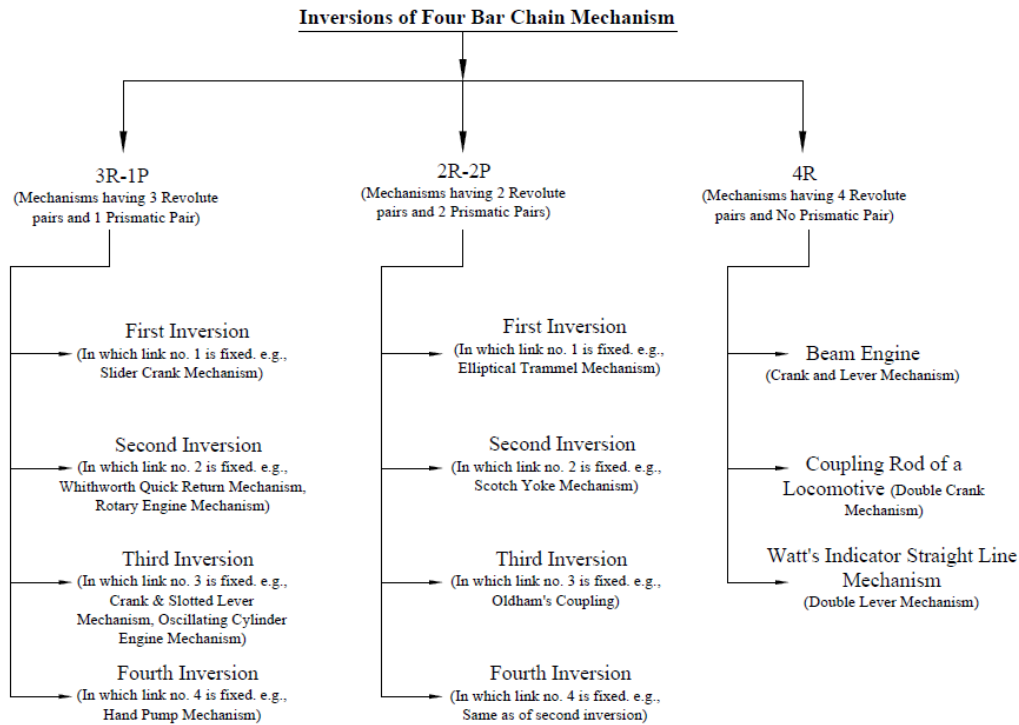

Figure: 8 Inversions of Four Bar Chain Mechanism

Inversions of 3R-1P or Single Slider Crank Mechanism

First Inversion of 3R-1P: As we already know that first inversion means when we will fix link number 1 of four bar chain mechanism. Slider crank mechanism is one example of it as shown in figure.

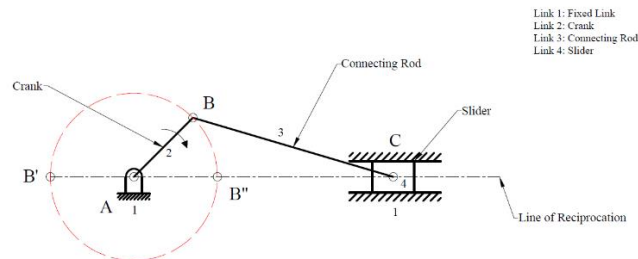

Figure: 9 First Inversion (Slider Crank Mechanism)

The main function of this mechanism is to convert the rotary motion of crank into reciprocating or rectilinear motion of the slider and vice-versa. Here the three R-pairs are placed in between link 1&2, 2&3 and 3&4 and one P-pair is in between link 4&1.

Working of Slider Crank Mechanism: Let us say initially, when point B is at B', then point C will be at its extreme left position. When we will give an angular rotation to crank and it will move from B' to B'' clockwise, then point C will reach to its extreme right position and it will have its forward motion. Now, with the further movement of the crank from B'' to B' clockwise, then point C will move from extreme right position to extreme left position and it will have its return motion/stroke. The distance between the two extreme positions is termed as stroke length and it will be twice of crank length.

Second Inversion of 3R-1P: Second inversion means when we will fix link no. 2 of slider crank mechanism, then it will be called as second inversion of 3R-1P. Here, now the link no. 1 is free to move and crank i.e., link no. 2 will be fixed. Here, again the three R-pairs will be in between link 1&2, 2&3 and 3&4 links and one P-pair is in between link 4&1. The kinematic diagrams for this is shown in figures.

Here, now, link no. 3 will rotate about point B in a complete circle, and along with this link no. 1 will also rotate about point A in a circle and link no. 4 will reciprocate in link no. 1. Now, in order to make sliding of link no. 4 in link no. 1, we will cut a slot in between link no. 1 and that's why more often it is also called as a slotted bar.

In order to get a desired output of this inversion, let us say we have extended link no. 1 from A to D and further this D point is connected with the cutting tool or RAM. Here, when the link no. 3 will rotate or gave some rpm, then the point D will move in a circle w.r.t A. This mechanism is called as Whithworth quick return mechanism and is used in the workshops.

Working of Whithworth Quick Return Mechanism: Let us say, initially, when C point is at C', then D point will be at D' and the cutting tool will be at its extreme top position. Now, as link no. 3 will rotate say counter-clockwise/anticlock-wise from C' to C'', the cutting tool will reach from extreme top position to extreme bottom position and the point D will move from D' to D'' clockwise and cutting tool will have its forward stroke. Now, when point C will further move from C'' to C' counter-clockwise, cutting tool will reaches from extreme bottom position to extreme top position and the point D will move from D'' to D' conter-clockwise and cutting tool will have its return stroke.

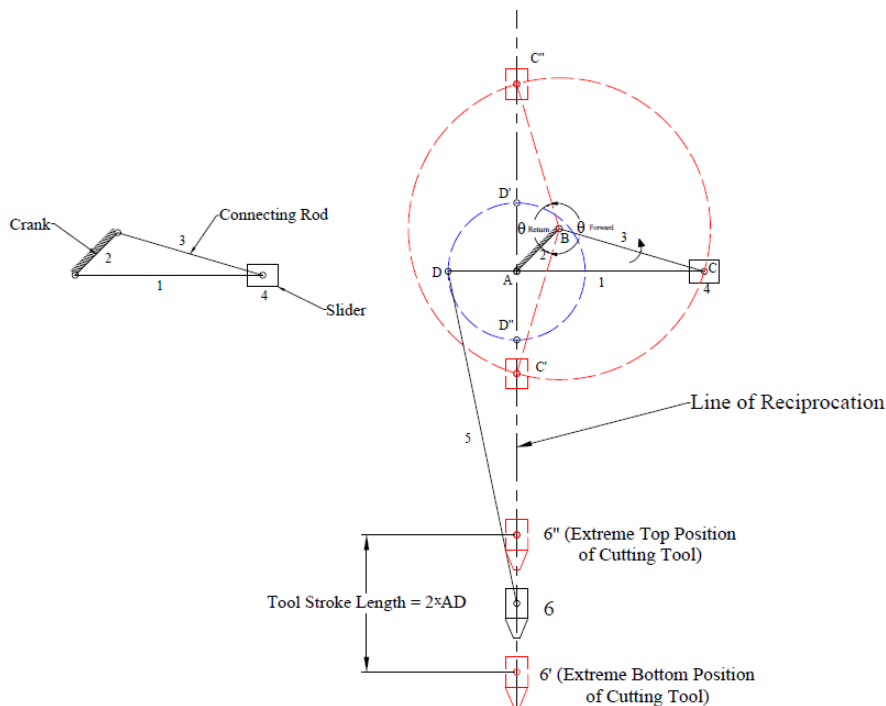

Figure: 10 Second Inversion (Whithworth Quick Return Mechanism)

Quick Return Ratio: As, link no. 3 is moving with constant angular velocity, therefore time taken by the cutting tool in forward and return stroke is directly proportional to angular displacement only. We can see

clearly in the diagram that angular displacement in forward stroke or cutting stroke is more as compare to return stroke or idle stroke. The ratio of angular displacement of forward stroke to the return stroke is termed as quick return ratio (QRR).

$$\text{Quick Return Ratio (QRR)} = \frac{\text{Time taken by the cutting tool during forward stroke}}{\text{Time taken by the cutting tool during return stroke}}$$

$$\text{Quick Return Ratio (QRR)} = \frac{\theta_{\text{Forward}}}{\theta_{\text{Return}}}$$

Third Inversion of 3R-1P: Third inversion means when we will fix link no. 3 of slider crank mechanism, then it will be called as third inversion of 3R-1P. Here, again the three R-pairs will be in between link 1&2, 2&3 and 3&4 links and one P-pair is in between link 4&1. The kinematic diagrams for this is shown in figures. We will explain two applications of this inversion i.e., oscillating cylinder engine mechanism and crank and slotted lever mechanism.

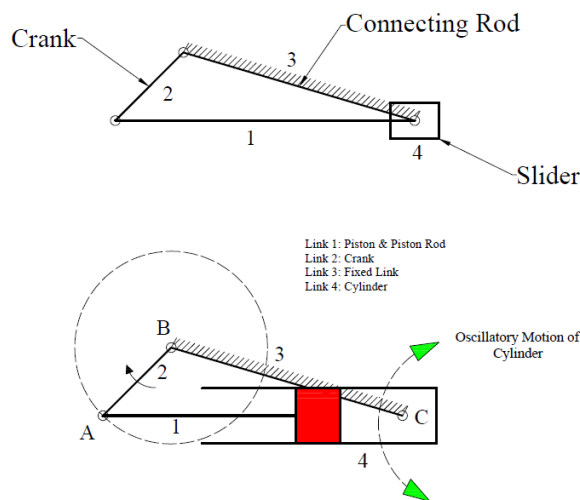

Figure: 11 Third Inversion (Oscillating Cylinder Engine Mechanism)

Working of Oscillating Cylinder Engine Mechanism: In this mechanism, link no. 3 is fixed. Now we will give an angular motion to link no. 2 (which is a crank) and it will rotate say in a clockwise direction about point B. Along with full rotation of the crank, link no. 4 which is a cylinder exhibits an oscillatory motion about point C which is a fix point. That's why it is called as oscillating cylinder engine mechanism. So, the function of this mechanism to convert uniform rotary motion to oscillatory motion.

Crank & Slotted Lever mechanism: This mechanism is also the third inversion of 3R-1P, where link no. 3 is fixed. This mechanism is mostly used in the workshops in shaper machine. Its function is to cut horizontal and vertical slots on a workpiece/job. It is a quick return mechanism, where forward stroke of cutting tool will takes longer time as compare to return stroke. So, forward stroke is also called as a cutting stroke and

return stroke is called as idle stroke. In idle stroke, there is no cutting of material from the workpiece/job. The kinematic diagrams of the mechanism is shown in the figure.

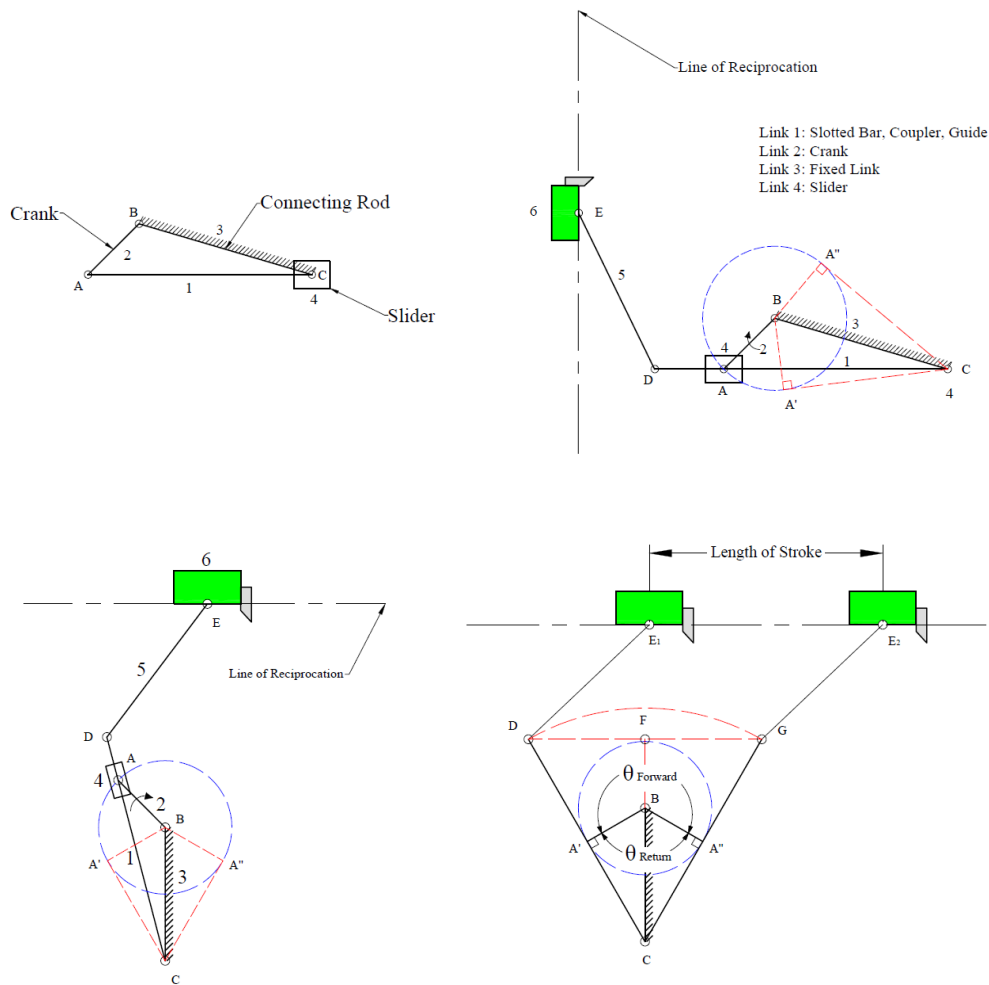

Figure: 12 Third Inversion (Crank & Slotted Lever Mechanism)

Working of Crank & Slotted Lever Mechanism: As we know that in this mechanism, link no. 3 is fixed. Now, we will give an angular motion to link no. 2 (which is a crank) and it will rotate say in a clockwise direction about point B. Initially, when point A will be at A' then point E will be at E₁, which means that cutting tool or RAM will be at its extreme left position or bottom position. Now, when the crank moves from A' to A'' in a clockwise direction, point E will move from E₁ to E₂ and the cutting tool will have its forward stroke or cutting stroke. With the further movement of the crank from A'' to A' clockwise, the cutting tool will move from E₂ to E₁ and the cutting tool will have its return stroke or idle stroke. The distance between the points E₁ and E₂ will be termed as the length of stroke of the cutting tool.

We can see clearly in the diagram that the angular displacement in the forward stroke or cutting stroke is more compared to the return stroke or idle stroke. The ratio of angular displacement of the forward stroke to the return stroke is termed as the quick return ratio (QRR) as already discussed in the Whitworth quick return mechanism.

Difference Between Whithworth Quick Return Mechanism and Crank & Slotted Lever Mechanism

As we can see that both the mechanisms are quick return motion mechanisms, and both will be used in workshops. But there are some differences in between both of them, which are mentioned in table no. 3.

Table 3: Difference Between Whithworth Mechanism and Crank & Slotted Lever Mechanism

S. No.	Whithworth Quick Return Mechanism	Crank & Slotted Lever Mechanism
1.	Length of crank i.e., link no. 3 in whithworth quick return mechanism is more as compare to the fixed link.	Length of crank i.e., link no. 2 in crank & slotted lever mechanism is less as compare to the fixed link.
2.	Coupler link, which is link no. 1 in whithworth quick return mechanism makes complete revolution with the crank.	Coupler link, which is link no. 1 in crank & slotted lever mechanism oscillates about a pivoted point.
3.	In it, the extension point i.e., D is taken on the extension of the coupler link/slotted bar i.e, link no. 1	In it, the extension point i.e., D is taken beyond the extreme position of the slider on slotted bar i.e., link no. 1

Fourth Inversion of 3R-1P: Fourth inversion means when we will fix link no. 4 (i.e., slider) of slider crank mechanism, then it will be called as fourth inversion of 3R-1P. Here, again the three R-pairs will be in between link 1&2, 2&3 and 3&4 links and one P-pair is in between link 4&1. The kinematic diagrams for this is shown in figures. Hand pump mechanism is the application of this inversion.

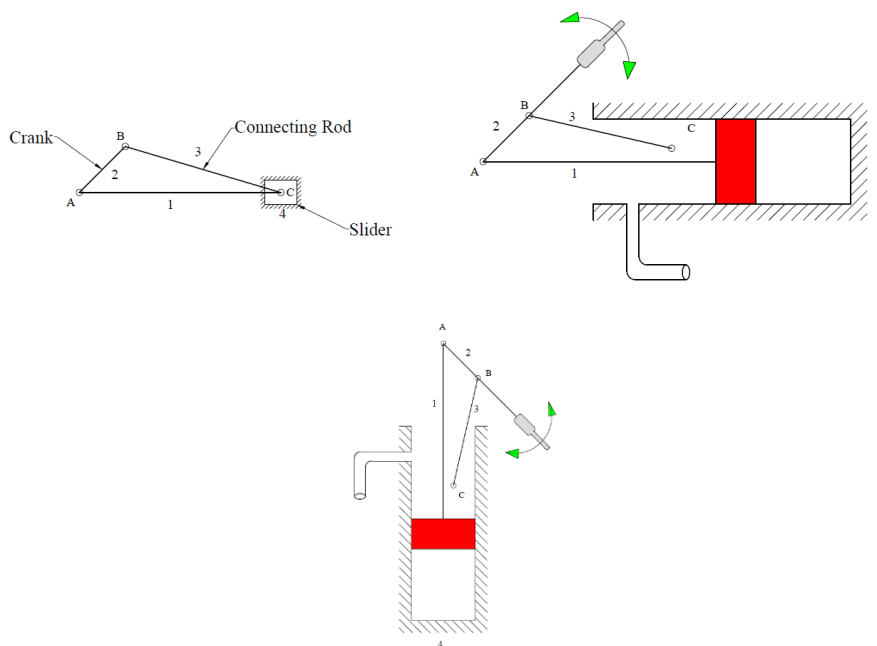

Figure: 13 Fourth Inversion (Hand Pump Mechanism)

Working of Hand Pump Mechanism: As we know that in this mechanism, link no. 4 (slider) is fixed. Now, in order to achieve a desired output, let us extend link no. 2 as per our requirement. Now, we will give an angular or oscillatory motion to link no. 2 (which is a crank) and link no. 1 will reciprocate in link no. 4 horizontally or vertically. It must be noted here that when link no. 2 will give an angular motion, then link no. 3 will also oscillate about point C, which is attached to the fixed link 4 at any convenient point. The

function of this mechanism is to convert oscillatory motion of crank into reciprocating or rectilinear motion of piston and piston rod.

Inversions of 2R-2P or Double Slider Crank Mechanism

As we know that in a four-bar chain mechanism, when there are two revolute pairs and two prismatic pairs between their kinematic pairs, then it is said to be a 2R-2P mechanism. The kinematic diagram for this is shown in the figure, where two prismatic pairs are at right angle to each other. In this inversion, there are two revolute pairs in between link 2&3 and link 3&4. Also, here there are two prismatic pairs first in between 1&2 in a horizontal direction and second in between 1&4 in a vertical direction.

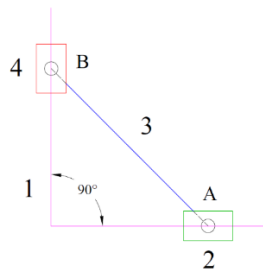

Figure: 14 2R-2P Mechanism

First Inversion of 2R-2P: When we will fix link no. 1 of four bar chain mechanism in 2R-2P, then it is said to be a first inversion of 2R-2P. Elliptical Trammel is one example of it as shown in figure.

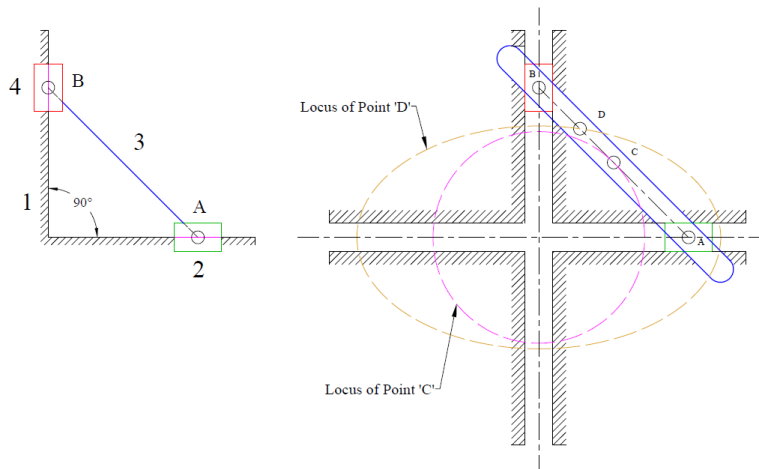

Figure: 15 First Inversion of 2R-2P (Elliptical Trammel)

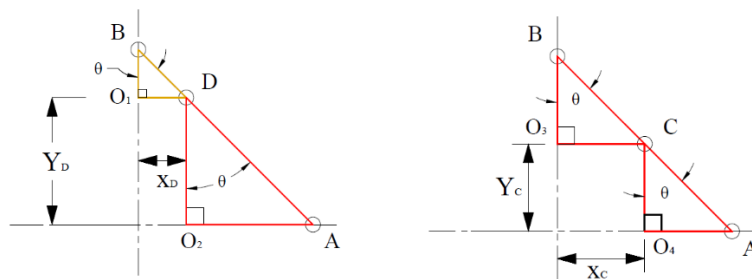

Figure: 16 Coordinates of Point C & D

Let at any instant of time, link no. 3 will move say in counter clockwise direction with some angular velocity and making an angle of θ with vertical axis. Now, let us look out the coordinates of point D and C at this instant.

Coordinates of Point D: -

In ΔO_1DB , For X-Coordinates, $\sin \theta = \frac{O_1D}{BD} = \frac{X_D}{BD}$ ----- (6)

And, In ΔO_2AD , For Y-Coordinates, $\cos \theta = \frac{O_2D}{AD} = \frac{Y_D}{AD}$ ----- (7)

Squaring and adding equation no. 6 & 7, we will get

$$\sin^2 \theta + \cos^2 \theta = \left[\frac{X_D}{BD} \right]^2 + \left[\frac{Y_D}{AD} \right]^2$$

$$1 = \left[\frac{X_D}{BD} \right]^2 + \left[\frac{Y_D}{AD} \right]^2 \text{----- (8)}$$

Equation no. 3 is the equation of an ellipse, which means that point D will move in an ellipse. In it, BD and AD are the semi-minor and semi-major axis of an ellipse. That's why it is named as Elliptical Trammel.

Coordinates of Point C: -

In ΔO_3CB , For X-Coordinates, $\sin \theta = \frac{O_3C}{BC} = \frac{X_C}{BC}$ ----- (4)

And, In ΔO_4AC , For Y-Coordinates, $\cos \theta = \frac{O_4C}{AC} = \frac{Y_C}{AC}$ ----- (5)

Squaring and adding equation no. 1 & 2, we will get

$$\sin^2 \theta + \cos^2 \theta = \left[\frac{X_C}{BC} \right]^2 + \left[\frac{Y_C}{AC} \right]^2 \text{----- (6)}$$

Since, BC and AC are equal, because C is the mid-point of A and B points. Therefore, equation no. 6 will become

$$1 = \left[\frac{X_C}{BC} \right]^2 + \left[\frac{Y_C}{BC} \right]^2 \text{----- (7)}$$

$$BC^2 = [X_c]^2 + [Y_c]^2 \text{----- (8)}$$

Equation no. 8 is the equation of a circle, which means that point C will move in a circle.

Second Inversion of 2R-2P: When we will fix link no. 2 (slider) of 2R-2P inversion, then it is said to be a second inversion of 2R-2P. Scotch yoke mechanism is one example of it as shown in figure. It must be noted here that link no. 2 & 4 both are sliders, so if we fix either one of them, it results in same application. That's

why we will have only three inversions for 2P-2R. The kinematic diagram for scotch yoke mechanism is shown in figure.

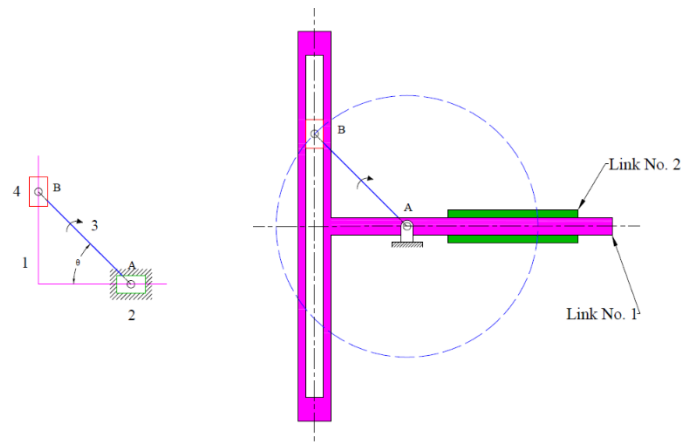

Figure: 17 Second Inversion of 2R-2P (Scotch Yoke Mechanism)

In this mechanism, link no. 3 is rotating about point A (say in a clock wise direction). With the angular motion of link no. 3, link no. 1 will reciprocate along link no. 2. The function of this mechanism is to convert a uniform rotary motion into reciprocating motion. It results in a perfect simple harmonic motion of link no. 1.

In order to find out the displacement of link no. 1 at any instant of time, we know that link no. 1 is rotating with some angular velocity.

$$\omega = \frac{\theta}{t}$$

Now, let us say 'x' is the displacement of link no. 1 and mathematically it can be represented as

$$x = l_3 \cos \theta \text{ ----- (9)}$$

$$x = l_3 \cos \omega t \text{ ----- (10)}$$

Where, $l_3 = \text{Length of link no. 3}$

Equation no. 10, is a simple harmonic equation. That's why this mechanism is used to convert uniform rotary motion into reciprocating motion and it will be a pure simple harmonic motion.

Third Inversion of 2R-2P: When we will fix link no. 3 (coupler or connecting rod) of 2R-2P inversion, then it is said to be a third inversion of 2R-2P. Oldham's coupling mechanism is one example of it as shown in figure. The kinematic diagram for scotch yoke mechanism is shown in figure.

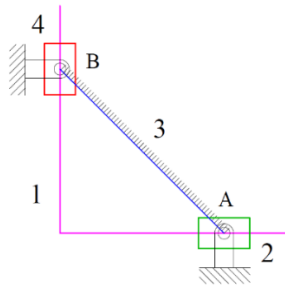

Figure: 18 Third Inversion of 2R-2P

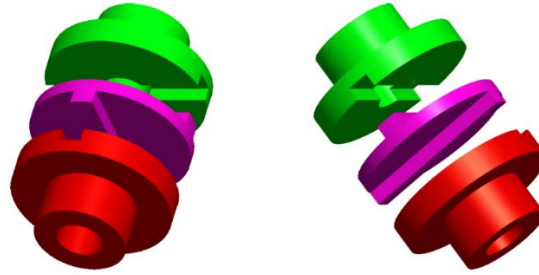

Figure: 19 Third Inversion of 2R-2P (Oldham's Coupling)

In this mechanism, link no. 2 & 4 will rotate about point A & B respectively. Link no. 1 will have two prismatic pairs with link no. 2 & 4 in a horizontal and vertical direction respectively and angle between both prismatic pairs will be 90°.

Working of Oldham's coupling

It is used to transmit power from input to output shaft, whose axes are parallel but having a little offset between them. It transmits a uniform angular velocity ratio between two shafts. Here, when we will give an angular motion to link no. 2, it will rotate link no. 1 in the same direction and it will also slide in a horizontal direction w.r.t link 2. Further, as we know that link no. 1 is having a prismatic pair with link no. 4 in vertical direction, so it will rotate and slide in a vertical direction w.r.t link no. 1 and transmits the power. It must be noted here that link no. 2 and 4 will rotate at their fixed positions and link no. 1 apart from rotating, it will also slide in a horizontal and vertical direction w.r.t link no. 2 & 4 respectively.

If, ' ω ' is the angular velocity of input and output shaft and ' y ' is the distance between the axes of shafts (i.e., offset distance between the axis of input and output shaft), then maximum sliding velocity between the prismatic pairs will be:

Maximum sliding velocity

$$= \text{Angular velocity of shafts} \times \text{Offset distance between axis of shafts}$$

$$v = \omega \times r$$

Note: This coupling is not useful when the offset distance between two shafts is very large because of large power loss due to friction between the prismatic pairs.

Inversions of 4R Mechanism

In 4R mechanism, there will be four revolute/turning pairs at each joint. There are so many applications of 4R mechanism. Therefore, we will study only some of them which are important.

1. Beam Engine Mechanism (Crank and Lever Mechanism)
2. Coupling Rod of a Locomotive Engine Mechanism (Double Crank Mechanism)
3. Watt's Indicator Mechanism (Double Lever Mechanism)

1. Beam Engine Mechanism (Crank and Lever Mechanism): Beam engine mechanism is also known as crank & lever mechanism. Here, when we will an angular motion to link no. 2 (crank), then link no. 4 (lever)

will oscillate about point E. Now, in order to get a useful motion, link no. 5 (piston & piston rod) will be connected at point D, which will now reciprocate along the cylinder. So, the function of this mechanism is to convert uniform rotary motion of crank into reciprocating motion of piston. Here four R-pairs will be at A, B, C & E points.

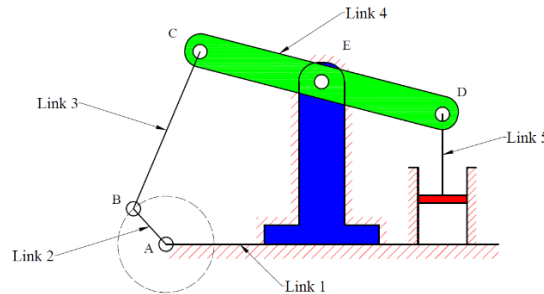

Figure: 20 Beam Engine Mechanism (Crank and Lever Mechanism)

2. Coupling Rod of a Locomotive Engine Mechanism (Double Crank Mechanism): Here, in this mechanism we have two cranks having equal lengths. Both the cranks are connected to the respective wheels. In this, BC link acts as a coupling rod and the link AD is fixed in order to maintain the constant center to center distance between two wheels. The function of this mechanism is to convert uniform rotary motion of one crank to the uniform rotary motion of other crank, which then rotate the locomotive wheels.

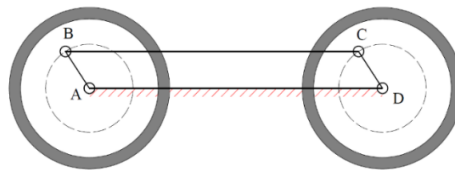

Figure: 21 Coupling Rod of a Locomotive Engine Mechanism (Double Crank Mechanism)

3. Watt's Indicator Straight Line Mechanism (Double Lever Mechanism): Watt's indicator straight line mechanism is also known as double lever mechanism. James Watt invented this linkage. It consists of four links, which are shown with different colors in the figure also. Here, Link no. 3 (BC) and link no. 4 (DEF) acts as a lever. In this mechanism, the displacement of the link no. 4 is directly proportional to the pressure or steam which is acting on the indicator plunger. For small displacement of this mechanism, point C will trace out approximately a straight line.

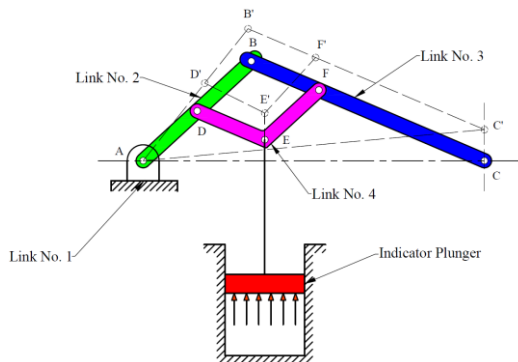

Figure: 22 Watt's Indicator Mechanism

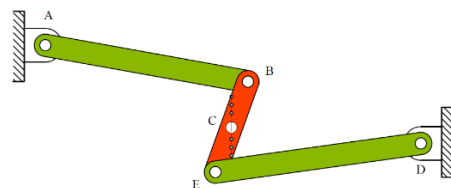

Figure: 23 Straight Line Mechanism

Application of this mechanism can be found in the suspension system of some automobiles in rear axle. It allows the axle of an automobile to move in a vertical direction and prevents the sideways motion of axle as shown in figure below.

VI. CONCLUSION

In conclusion, our journey into the fundamentals of the Theory of Machines and Mechanism Inversions has opened doors to a world of marvels and innovations. Mechanism inversions, an enthralling aspect of this study, allow us to examine alternative configurations of machines, offering unique solutions to engineering challenges. By exploring diverse combinations of links and joints, mechanism inversions enable the development of innovative designs with improved functionalities and versatility. This understanding of fundamental concepts fosters a deeper appreciation for the intricate mechanisms surrounding us, from everyday devices to complex industrial machinery and cutting-edge robotics. The application of these principles has been instrumental in shaping human progress, driving technological advancements, and elevating the standards of living worldwide. Looking ahead, further research and exploration in this field promise to yield even more remarkable innovations. As technology continues to evolve, the Theory of Machines will remain a cornerstone of mechanical engineering, inspiring the next generation of engineers to dream big and push the boundaries of machine capabilities.

In essence, our journey of "Exploring Fundamentals: Theory of Machines and Mechanism Inversions" not only deepens our understanding of mechanical systems but also sparks curiosity and excitement for the boundless possibilities that lie ahead. Armed with a solid grasp of these foundations, engineers will continue to shape a world where machines and mechanisms seamlessly blend ingenuity and functionality to create a better, more efficient, and interconnected society.

REFERENCES

- [1] Amitabha Ghosh and A.K. Malik, Theory of Mechanisms and machines, East West Press, 2009
- [2] S.S. Rattan, Theory of Machines, Tata McGraw Hill Education Pvt. Ltd. 2009
- [3] R.S. Khurmi and J.K. Gupta, Theory of Machines, S. Chand Publishing, 2007