

# Smart Navigation Assistance System for the Visually Impaired

Mallamma C G  
Department of Computer Science and  
Engineering  
Sambhram Institute of Technology  
Bangalore, India  
[mallammagoudar79@gmail.com](mailto:mallammagoudar79@gmail.com)

Nagapushpa K P  
Department of Electronics and  
Communication Engineering  
Acharya Institute of Technology,  
Bangalore, India  
[nagapushpa@acharya.ac.in](mailto:nagapushpa@acharya.ac.in)

Varalakshmi B D  
Department of Computer Science and  
Engineering  
Acharya Institute of Technology  
Bangalore, India  
[varalakshmi@acharya.ac.in](mailto:varalakshmi@acharya.ac.in)

Anuradha U  
Department of Computer Science and  
Engineering  
Sambhram Institute of Technology  
Bangalore, India  
[anu.charana@gmail.com](mailto:anu.charana@gmail.com)

## Abstract

*There are several hassles in daily life for visually challenged people. In light of this, it is very important to focus on the needs of those who are visually impaired. To help people who are vision impaired to enjoy normal lives, researchers approach the issue from a variety of angles. The white cane is the support system and it enables a sense of being free, independent and self-assured. They can easily take care of their daily tasks thanks to the proposed smart cane's design, which includes an obstacle detection module, heat detection, water detection, light detection, pit and staircase detection using Infrared (IR) sensors, Global Positioning System (GPS), and Global System for Mobile (GSM). The obstacle detection module detects obstacles using ultrasonic range and a camera, intimating the user of the obstacle's detection as well as details about the obstacle. The Raspberry Pi is used to send a voice message through the headset to the visually impaired user regarding the information about what the object is. The person's current location is determined using the GPS and provided as a text message as well as a voice message using a headset. Raspberry Pi is made use of to identify traffic lights, and it notifies the user via a headset whether to wait for the signal or move. If the blind person loses the cane, none of the above mentioned conveniences are available. To accomplish this, an alarm is fixed inside the smart cane which is coupled to their mobile phones. This alarm is used for finding the smart cane if it is missing or placed elsewhere.*

**Keywords-Smart cane, Raspberry pi, visually impaired, YOLO Algorithm**

## I Introduction

Among all the sensory organs, the eyes are for the visual system which performs a major role of fundamental human senses. Persons who have visual difficulties frequently face physical impediments that limit their accessibility and movement. People must rely on others for both indoor and outdoor movements because of a vision impairment. Several companies attempt to produce electric equipment and gadgets for visually impaired persons to overcome their mobility difficulty without relying on others. Visual impairment can also be referred to as blindness in the eye or loss of the vision. The daily routine tasks such as reading, walking, socializing, and driving are very difficult to complete due to visual disability. The white cane helps the blind person in achieving a sense of freedom, no dependence on others and strong belief in themselves. An intelligent navigation system for visually challenged people is suggested as a solution to this problem. [5][8][14][16]

The suggested system carries out continuous object observation and detection operations. The surrounding environment can be captured and given as a voice command. The heart beat sensor measures the heart rate of the person. The suggested technology successfully tracks visually impaired people in real time and enables the individual to walk around safely. The GAP's major goal is to make sure that people with limitations in their visual system can have access to care and to prevent visual loss as a global public health issue.

Researchers engaged in the areas of navigation equipment development have yet to discover technical solutions for guiding visually impaired persons in an efficient, safe, and cost-effective manner. The prospective system achieves the following targets: providing a smart navigation system for obstacle detection, voice-based recognition, health monitoring, and visual impairment tracking. [4][14][16]

### 1.1 Introduction to YOLO Algorithm

The YOLO algorithm significantly outperforms all the parameters that are covered, and it also offers a high frame rate for real-time use. The regression method is the foundation of this approach. Bounding boxes are created in this method

to process the image in only one pass, as opposed to just picking the focal point of the picture.

The YOLO algorithm can be completely implemented after understanding what it is actually predicting. Eventually, the aim is to predict objects class and the box which is bounded to specify the object location. Each bounding box can be described using four descriptors- the center of the bounding box is given by two parameters  $b_x$  and  $b_y$ , width is given by  $b_w$  and the height by  $b_h$  where the value  $c$  corresponds to the objects class. Additionally, an actual number  $p_c$  is forecast, which represents the probability that an object is present within the bounding box. Rather than looking for prospective object-containing parts in the image which is given as the input, YOLO divides the image into cells, usually in the form of a grid which has 19 rows and 19 columns. The next step is for each cell to predict  $K$  bounding boxes.

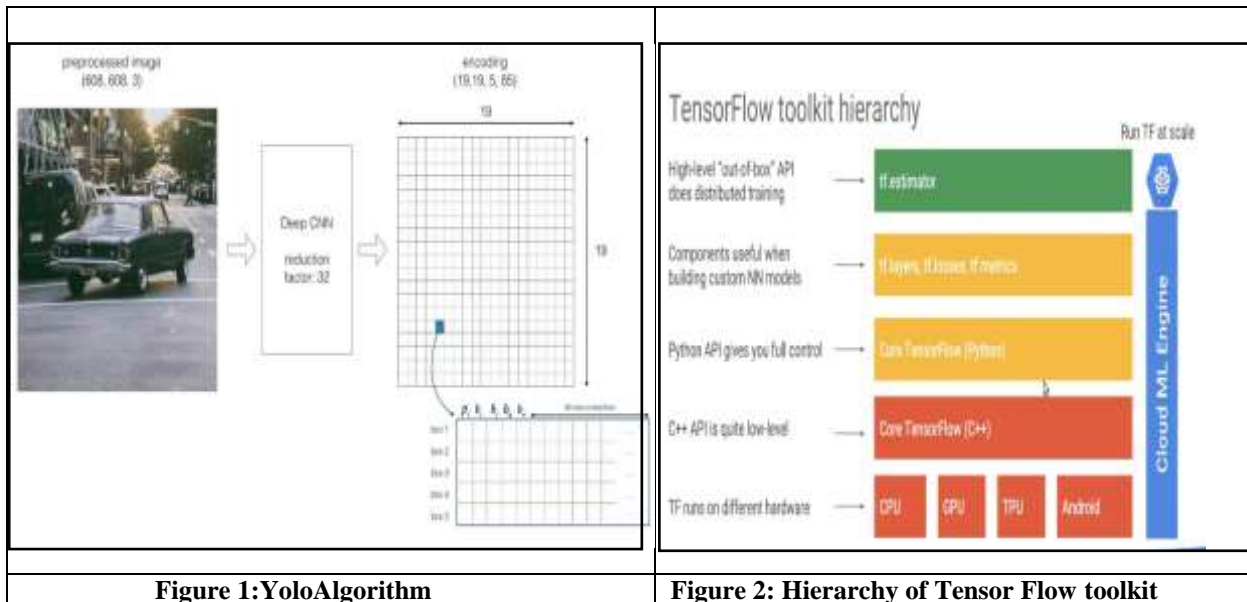

An object is considered to lie in a specific cell only if the anchor box center coordinates lie in that cell. Due to this characteristic, the coordinates at the center are always computed with reference position to the cell whereas the height and width are computed with respect to the size of the complete image. Within the one pass of transmission in the onward direction, the YOLO algorithm finds the possibility that the cell contains a specific class. The equation is given as:

$$\text{Score}_{c,i} = p_c \times c_i$$

which indicates that a chance is there so that  $c$  of a specific class can create objects.

### 1.2 Tensor Flow

Tensor Flow is a complete open source machine learning platform. Tensor Flow is a strong and reliant system for controlling all parts of a machine learning system; however, this session concentrates on developing and training machine learning models using a specific Tensor Flow API. Figure 2 shows the hierarchy of Tensor Flow toolkits. TensorFlow is a free and open-source machine learning and artificial intelligence software library. It can be used for a variety of tasks, but it focuses on deep neural network training and inference. [7]

### 1.3 Convolutional Neural Networks

Convolutional neural networks have become popular for classification techniques and are widely used in the computer vision domain. Before Convolutional neural networks, feature extraction approaches that were laborious and time-consuming were used for detecting objects in photos. A more upgradable methodology is delivered by convolutional neural networks to image classification methods and jobs related to recognition of the objects. CNNs derive the principles from the linear algebra branch, specifically matrix multiplication, which are utilized for identifying similar sequences present within an image. [9]

Convolutional neural networks are distinguished from other neural networks by their superior performance with image, speech, or audio signal inputs. They have three main types of layers, which are: Convolutional layer, Pooling layer and Fully-connected layer. [13]

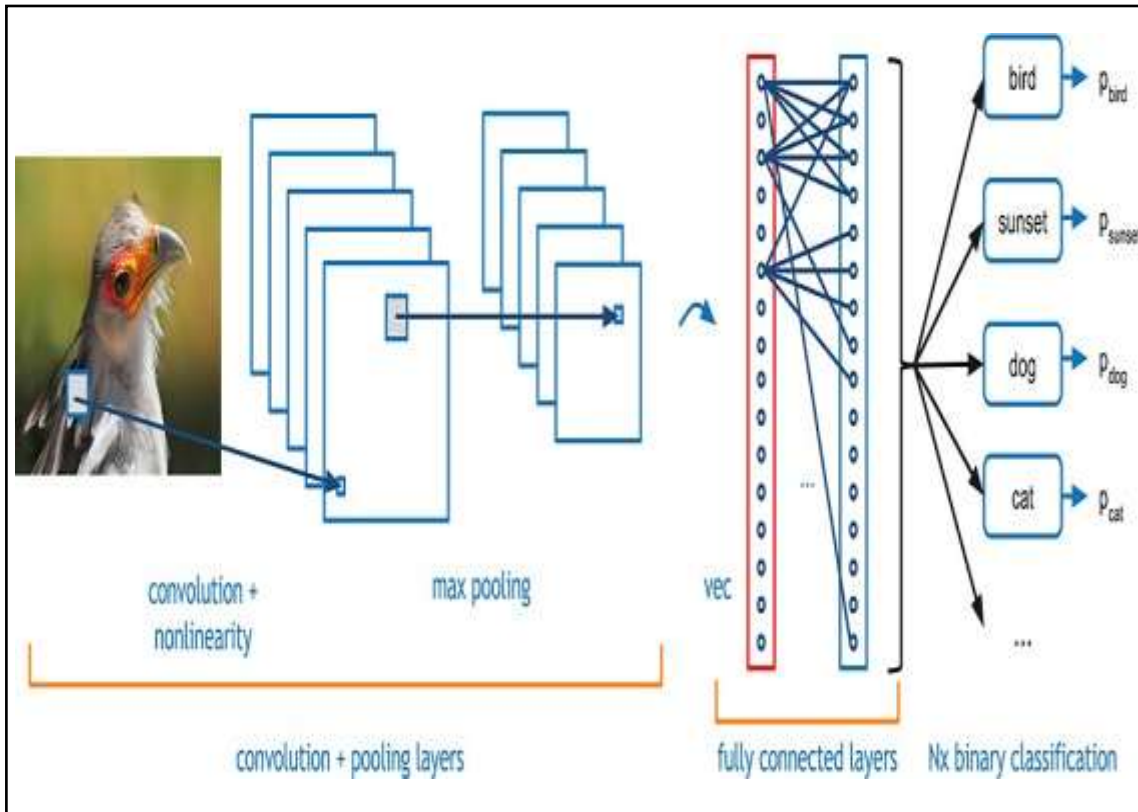

**Figure 3: Convolutional Neural Network**

## 1.4 Features of the Proposed Navigation System

### 1.4.1 Navigating Gadgets For Visually Impaired:

Navigating Gadget assists the people to travel and reach their destination path by using voice commands. The ultrasonic sensors are monitored by the microcontroller which are used for processing the obstacle detection. This device uses GPS to determine the user's location, and the headset receives information on how to get to their destination. Because of which it becomes easier for persons with disabilities to navigate the world on their own.

### 1.4.2 Cost Effective Autonomous Navigation System:

This technology is founded on the concept of robotics, and it uses an algorithm for detecting objects with the assistance of an ultrasonic sensor. This ultrasonic sensor is competent enough to detect objects that are placed in visible range of the user as well as on the floor to detect objects more precisely.

### 1.4.3 Touch and Sound Based System:

The computed ultrasonic range is used to locate the obstructions. The technology will measure the separation of the barriers from the individual and relay that measurement back to it. Through the headset, the user will receive notification of the obstacle's distance. If an obstruction comes into view, communication via voice will be provided to the person.

## II LITERATURE SURVEY

### 2.1 Preamble

The basic principles of user centric design including demerits of existing methods was studied by Santiago Real, Alvaro Araujo, (2019).[1] Cell phones and wearable with built-in cameras are suggested as theoretically viable alternatives to support state-of-the-art image recognition applications, facilitating both the attributes locality and tracking of the immediate environment of the consumer. In order to comprehend the process and outcomes, as well as to give aspiring designers an overall picture of device improvements that have arisen as a result of trial and error, this section also provides general aspects of the conventional design of guidance and navigational devices for the blind. This essay makes an effort to offer a comprehensive, multidisciplinary perspective of the study of navigational systems for this group. A new architecture scheme idea is then briefly addressed, along with the viability of modern as well as traditional designs. [1][9]

The work proposed by M. Murata, D. Ahmetovic, D. Sato, H. Takagi, K. M. Kitani and C. Asakawa, (2018)[2] discusses probabilistic smart phones localization algorithm that is utilized with inertial sensors along with mobile phones. The proposed model is practically experimented in a 21,000m<sup>2</sup> shopping mall which consists of three

multistoried complexes and a wide open basement walkway in the direction to approve the impact of the technologies introduced to improve the accuracy of the localization.[2][6]

The primary goal of the initial designs was to provide support for preventing obstacles. They served as stepping stones for the establishment of different gadgets that were later improved in terms of load, cost, consumption, consistency, etc. These employ vibrations to deliver customized info from the ultrasound transductions to the user. As an alternative, sensory substitution device research chose to primarily use sound or the sensation of touch to communicate visual perceptions to those who are blind and visually handicapped. However, as was already indicated, the heavy cognitive load restricted the quantity of information that the user could effectively integrate, which therefore decreased the overall impact and particularly those advancements connected to mobility. It is clear that locating technology has evolved into the foundation of navigation systems. Therefore, additional systems were required to monitor users along their trip due to the Global Navigation Satellite System's restricted coverage—for example, indoor signal obstruction—and inertial navigation's cumulative inaccuracy.[2][15][11]

2.2 The work done by G. Naveen balaji, S. Anusha and J. Aswini, 2017, was developed as a model that allowed the visually disabled to move in known and unknown areas without any assistance. The proposed model used Bluetooth technology for indoor navigation and GPS technology for outdoor navigation. The location of the people was provided by GPS based map assistance. The proposed model guided the paths to reach exact places by utilizing voice output received by the Bluetooth receiver. [9][12]

Ultrasound transmitters: As aforementioned, the University of Florida's Drishti project (2004) used this type of technology to guide people in the British Virgin Islands, integrating differential GPS outdoors and an ultrasonic transmitter infrastructure indoors. In terms of the latter, a mean error of roughly 10 cm and a maximum error of 22 cm was noted. However, accuracy can be quickly compromised due to signal interference, reflection, and other factors. [3] [6] [10]

Another notable system is that of the National University of Singapore (2004). This time, the position was determined using fluorescent lights, each with its own code to indicate the lighted area. As can be seen, this field of work shares characteristics with Li-fi. Furthermore, as batteries are removed, network lifetime rises while maintenance costs decrease, making them appealing choices for locating systems. Despite their limited range, range measuring techniques based on receive signal strength (RSS), received signal phase (RSP), or time of arrival (TOA) could be used. [3]

2.3 This model was proposed by Md. Mohsinur Rahman Adnan and Towhid Bin Alam, 2018, as a system based on audio guidance and ranging. The proposed system detected obstacles in real time by utilizing ultrasonic sensors and Infra-Red (IR) sensors. The image processing technique utilized the range and size of the obstacle in order to guide them to reach their destination in a safe manner.

Inertial navigation, Wi-Fi RSS readings, and stereo vision were some of the positioning methods used by these devices. Additionally, the information obtained by these sensors was used to identify previously modeled objects, such as pedestrians. Despite being error-prone, this feature was improved by restricting the set of potential neighboring items because some of them were linked to a static or semi-static position. (e.g., table, chair, etc.). From that point forward, the majority of BVI navigation systems would use a combination of technologies, which are typically categorized as indoor and/or outdoor solutions. Furthermore, they began to use the internet to collect supplementary data from outside sources. However, as the field of navigation systems advanced and the amount of data gathered for blind navigation increased, the demand for effective user interfaces increased.[6][10]

Many traditional systems used speech, initially with recorded messages (e.g., Guide Dog Robot, Sonic Pathfinder); later, speech synthesis and recognition were also gradually added. (e.g., Tyflos). Sensory substitution became an appealing alternative for blind navigation system user interfaces at this point, especially when the user required the system to quickly deliver detailed information about its immediate surroundings while keeping a minimal cognitive load. Once again, a pair of cameras is used to collect the 3D environment and communicate it to the user as tactile sensations in their fingertips.

The pulse width of electro tactile stimulation impulses was used to encode distance data. When the gloves were aligned with the cameras, it appeared that things were being touched from afar. [4]

### III Hardware Requirements

#### 3.1.1 Camera



**Figure 4: Fish Eye Camera**



**Figure 5: Fish Eye Camera View**

A camera is an optical device that collects visual images. Cameras, at their most basic, are sealed boxes (the camera body) with a small hole (the aperture) that allows light to pass through and capture an image on a light-sensitive surface (usually a digital sensor or photographic film). Cameras use a variety of methods to manipulate how light falls on a light-sensitive surface. Lenses focus the light entering the camera. The aperture can be narrowed or widened. There are two main variations of this lens: full-frame and circular. A full-frame shot will have the distorted image taking up the entirety of the frame. Meanwhile, a circular shot will have a black border surrounding the spherical shot. This gives off a convex, non-rectilinear appearance. And while it may be reserved for photography for the most part, you may just find a use for it in your next movie.

#### 3.1.2 Raspberry Pi

Raspberry Pi 4 Model B is the newest product in the popular Raspberry Pi range of computers. It has groundbreaking features in processor speed, multimedia performance, memory, and connectivity compared to the prior-generation Raspberry Pi 3 Model B+, while retaining backwards compatibility and similar power consumption. For the end user, Raspberry Pi 4 Model B provides desktop performance comparable to entry-level x86 PC systems.



**Figure 6: Raspberry Pi 4 kit (Model B)**

<b>Specification of Raspberry Pi 4 (Model B)</b>	
Processor	Broadcom BCM2711, quad-core Cortex- A72 (ARM v8) 64-bit SoC @ 1.5GHz
Memory	1GB, 2GB or 4GB LPDDR4 (depending on model)
Connectivity	2.4 GHz and 5.0 GHz IEEE 802.11b/g/n/ac wireless LAN, Bluetooth 5.0, BLE Gigabit Ethernet 2 × USB 3.0 ports, 2 × USB 2.0 ports.
GPIO	Standard 40-pin GPIO header (fully backwards-compatible with previous boards)
Video & sound	2 × micro HDMI ports (up to 4Kp60 supported) 2-lane MIPI DSI display port 2-lane MIPI CSI camera port 4-pole stereo audio with composite video port
Multimedia	H.265 (4Kp60 decode); H.264 (1080p60 decode, 1080p30 encode); OpenGL ES, 3.0 graphics supported by SD card, Micro SD card slot for extra memory and loading operating system
Input power	5V DC via USB-C connector (minimum 3A1 ) 5V DC via GPIO header (minimum 3A1 ) Power over Ethernet (PoE)-enabled (requires separate PoE HAT)
Environment	Operating temperature 0–50°C
Compliance	Compliance details can be viewed on the site mentioned here <a href="https://www.raspberrypi.org/documentation/hardware/raspberrypi/conformity.md">https://www.raspberrypi.org/documentation/hardware/raspberrypi/conformity.md</a>
Production lifetime	The Raspberry Pi 4 Model B is in production upto at least January 2026.

### 3.1.3 Audio Headset



**Figure 7: Bluetooth Earphones**

Headphones are a pair of tiny speakers that are worn over the user's ears on or near the head. They are electro acoustic transducers, converting an electrical signal to a corresponding sound. Contrary to loudspeakers, which

transmit sound into the open space for anybody around to hear, headphones allow a single user to listen to an audio source quietly. Headphones are also mentioned as earphones, ear speakers, or, more commonly, cans. Using a cord or wirelessly via Bluetooth, Digital Enhanced Cordless Telecommunications, or FM radio, you can connect headphones to a signal source like an audio amplifier, radio, CD player, portable media player, mobile phone, video game console, or electronic musical instrument. [9][11]

### 3.1.4 Ultrasonic sensor



Figure 8: Ultrasonic Sensors HC – SR04

The distance of a target object by emitting ultrasonic sound waves, and converts the reflected sound into a form of electrical signal that is measured by an ultrasonic sensor which is an electronic device. The distance in between the sensor and the object is determined by the sensor. It measures the time it takes between the emissions of the sound by the transmitter to its contact with the receiver. The formula for this calculation is  $D = \frac{1}{2} T \times C$  (where D is the distance, T is the time, and C is the speed of sound ~ 343 meters/second).



Figure 9: Ultrasonic Sensor



Figure 10: Push Button

### 3.1.5 Push Button

A push-button switch is a mechanism that is used to regulate a certain part of a machine or process. Buttons are usually made of a hard substance, such as plastic or metal. The surface is usually flat or shaped to accommodate the human finger or hand, so as to be easily depressed or pushed.

#### IV SYSTEM DESIGN

The entire project's operation is depicted in system design. All of the technologies that have been mentioned are used to design our system. The raspberry pi is used in this system because it contains the camera connectivity and provides more accurate output compared to Arduino Uno. With the help of jumper cables, the Raspberry Pi is connected to a number of extraneous gadgets, including a battery bank, camera, push button, and ultrasonic sensors. The power supply is given to the power bank, the push button is customized. With a single press the system starts, the fish eye camera is turned on and it starts capturing the live video ahead of the blind person. The live video is being captured and it is processed through OpenCV of longitudinal and latitudinal resize. The images that are captured are applied with the YOLO V3 algorithm and bounding boxes are results that will give us the object description. In previous sections, numerous picture classification models were discussed

Assume there is only one significant object in an image while classifying it, and concentrate primarily on how to identify that object's category. However, the image typically includes a lot of items. In addition to knowing their categories, also their specific positions in the image, Object detection is a term used in computer vision that should be known.

A bounding box is used in object detection to characterize the spatial location of an object. The bounding box is rectangular, as determined by the upper-left corner's end coordinates and the lower-right corner's coordinates. To convert between these two representations, functions are used: `box_corner_to_center` translates the two-corner representation to the center-width-height presentation, and `box_center_to_corner` does the opposite. The input argument `boxes` should be a two-dimensional tensor of shape  $(, 4)$ , which is the number of bounding boxes.

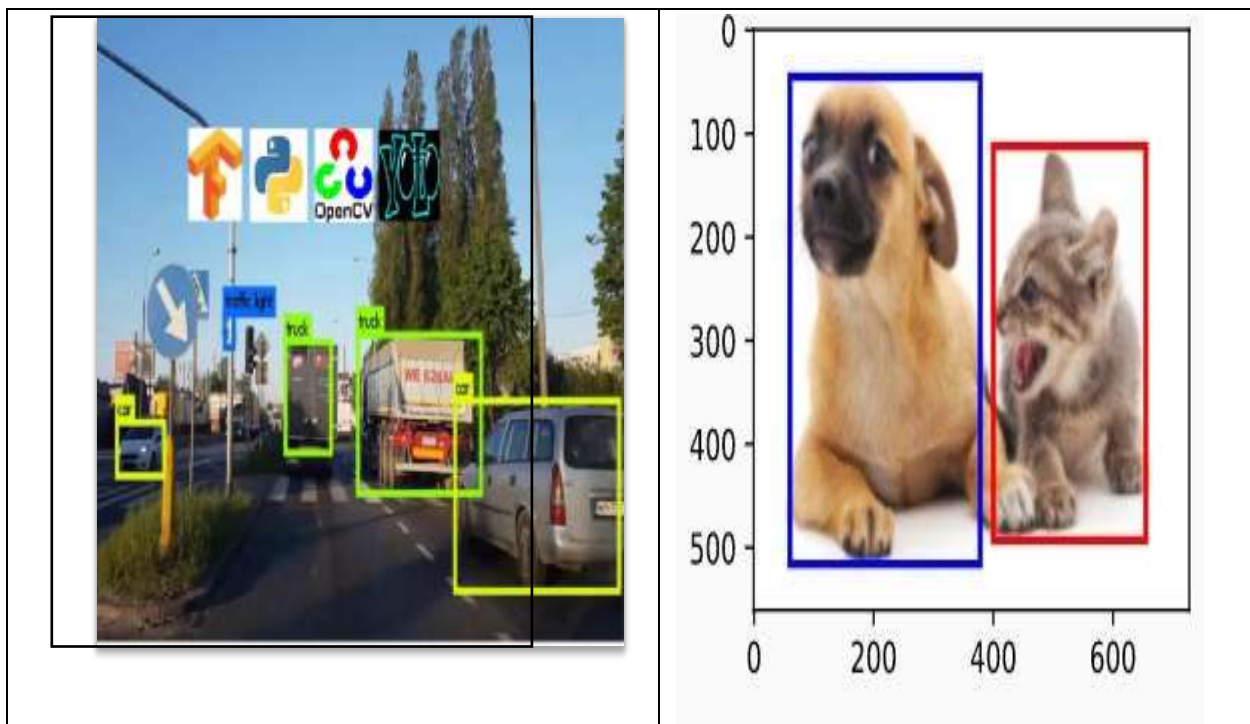

Figure 11: Detection of Objects

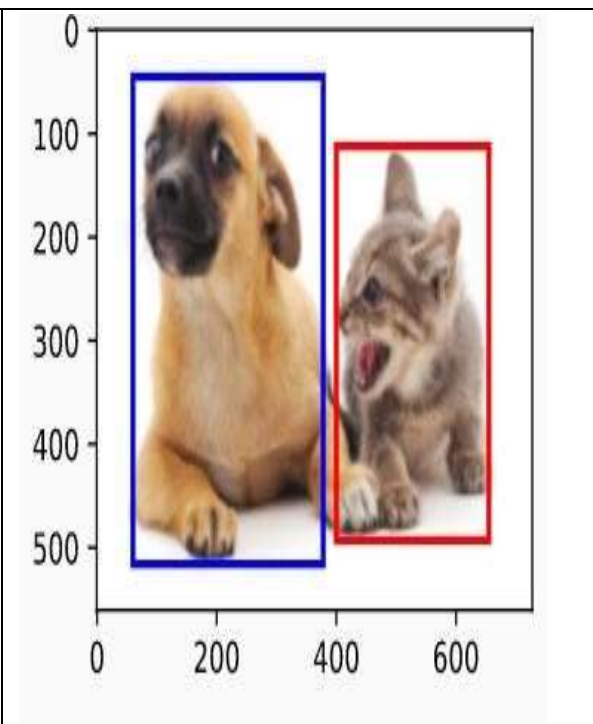
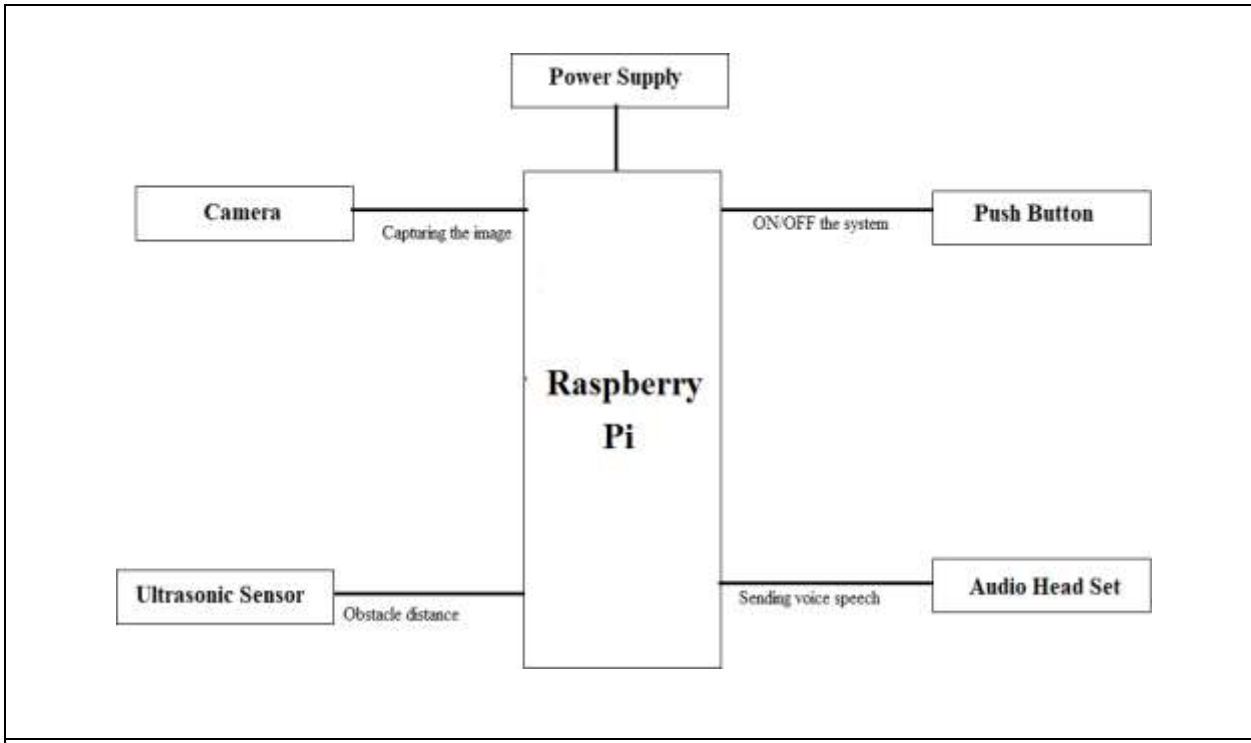

Figure 12: Graph Layout of Object Detection





**Figure 13: Block Diagram of System**

In addition to identifying everything in the image, object detection also determines where each object is located. A rectangular bounding box is commonly used to describe the position. Two popular bounding box representations are convertible. The confidence score reveals how likely the box contains an object of interest and how confident the classifier is about it. If no object exists in that box, the confidence score should ideally be zero. In general, the confidence score tends to be higher for tighter bounding boxes.

The 3 outputs that are produced are object detection, bounding boxes, and confidence score are given to the espeak software which is further sent to the audio headset. Ultrasonic sensor is effectively used for finding the distance of the obstacle from the visually challenged person. It gives out signals that will hit the object and return back giving the distance of the obstacle every few milliseconds. It sends an ultrasonic pulse out at 40 kHz which travels through the air and if there is an obstacle or object, it will bounce back to the sensor.



**Figure 14: Detection of Dog**

Figure 14: Detection of dog where  $P_c$  is the probability of the class. If it's a dog or man, it is  $P_c$  will be 1, else if there is no dog or no person it will be 0. Then  $B_x$  and  $B_y$  are the bounding box, coordinates of the center where 60 and 70 is the width and height of the bounding box ( $B_w$  and  $B_h$ ),  $C_1$  is class of dog: 1,  $C_2$  is for person, it will be zero.

- ❖ By calculating the travel time and the speed of sound, the distance can be calculated. Ultrasonic sensors are a great solution for the recognition of flawless objects. X meter is produced through ultrasonic sensors. All the results are fed to the espeak software where TTS is applied. TTS meaning text to speech software where the words are read and converted to an audio and this is sent to the blind person through the audio headset. This process happens every few milliseconds and continuously the information will be fed to the blind person. In brief the surrounding info and object detected info is sent to the board for every few seconds. Using a deep learning approach that is Tensor Flow object detection, objects can be detected and recognized. With the help of open source language python, objects are recognized and characterized using frozen inference models. Under Yolo there are various classes of objects, so the bounding boxes are processed to match with the classes of objects to detect the obstacle.
- ❖ The objects are stored in text format. The stored text is converted to TTS, which is text to speech in eSpeak software to pass the message about the obstacle to the visually impaired person via a headset.

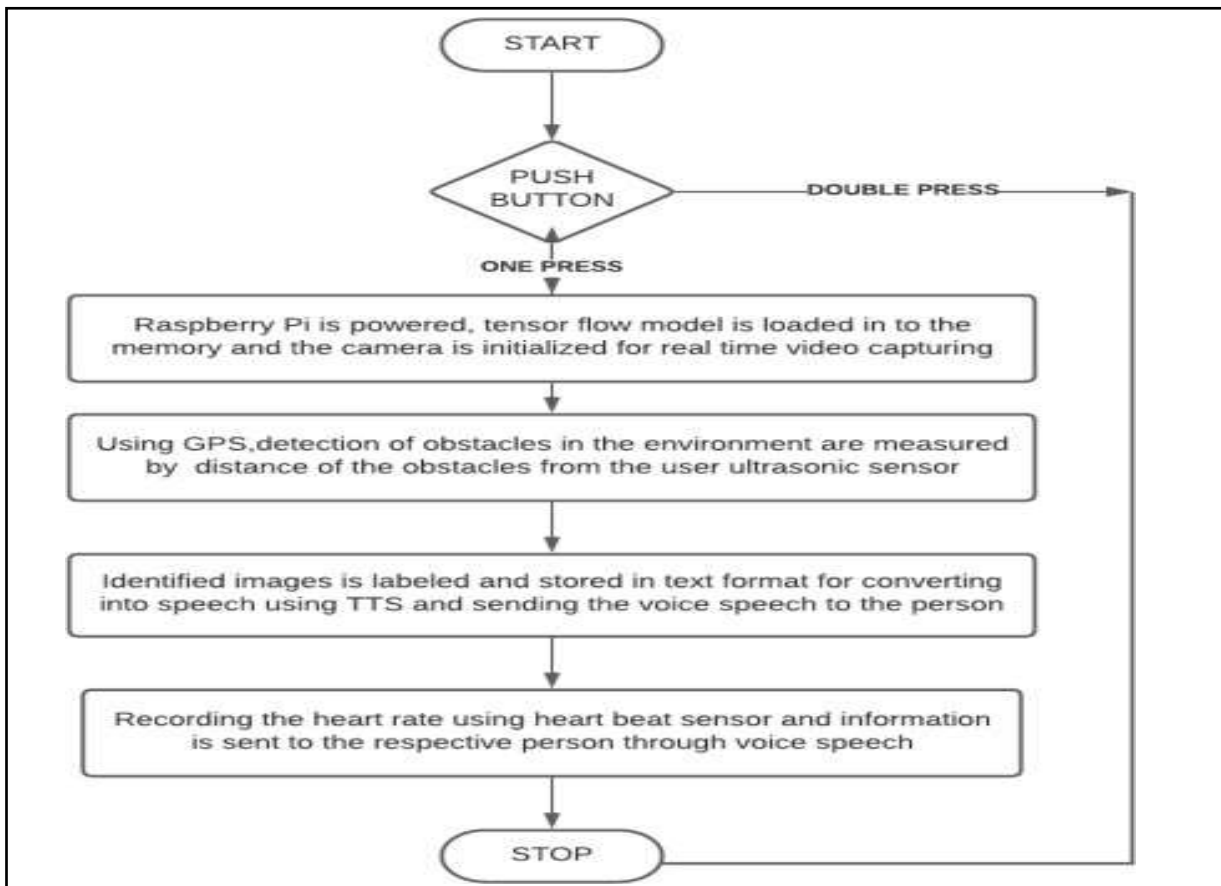

Figure 15: Flow Chart of System

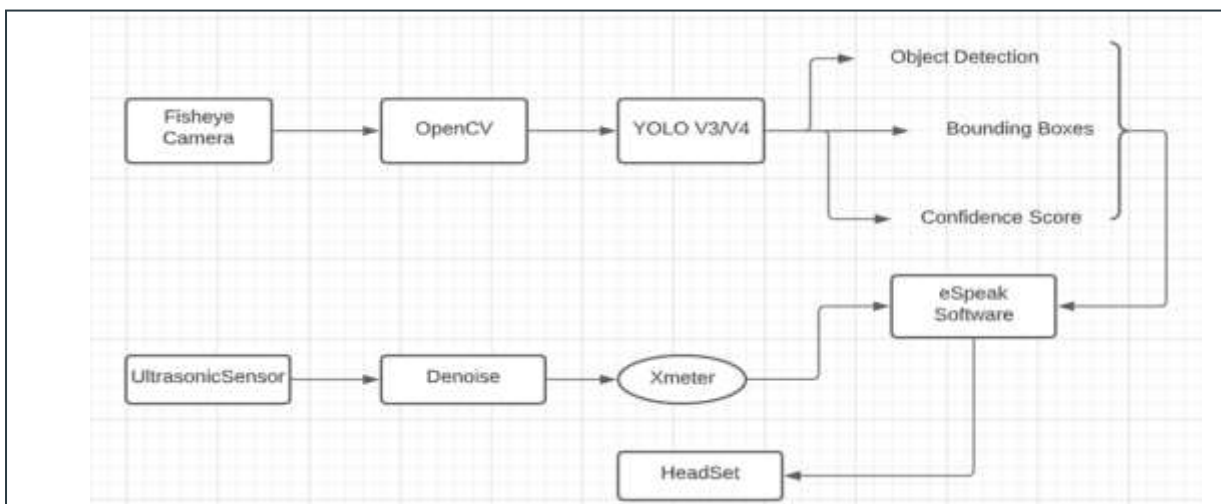

Figure 16: Working of System

## V RESULTS

The following are the results of the project where the code that was written has been tested and executed to fulfill the object detection criteria. Several classes of objects are detected using the live fish eye camera and the FPS rating is also shown. It tells the accuracy score. This code can be further implemented in the raspberry through modules and enhanced to help the blind person through voice based recognition. The images below show the executed outputs where a bottle and cell phone and a person are tested here to detect. The test run is successful and hence it can be concluded that our project aim of object detection is successful. Further the test was done in an outside atmosphere where the code was tested against the road, car, and trucks. The object detection was successfully tested and implemented. The objects were detected right and the output was given with the accuracy score.



**Figure 17: Detection of Bottle**



**Figure 18: Detection of Cell phone**



**Figure 19: Detection of Truck**



**Figure 20: Detection of Car**



**Figure 21: Detection of Potted plant**

## VI CONCLUSION

The proposed navigation guidance system is extremely useful in helping the blind persons. The proposed system not only provides guidance to the people, but also performs health monitoring of the blind or visually challenged persons. The persons with visual impairment can easily be tracked during the emergency situation using a GPS module. The guardian people get alerted regarding the wellbeing challenges of the visually challenged persons through SMS using the GSM module. The obstacle detection can be alerted to the people as voice output. The people don't need any specific training in order to utilize the proposed system, hence the system is user friendly. In the proposed system, a frozen inference model containing 300 pre trained models is utilized for obstacle identification. So the proposed system ensures better quality of life and removes the dependence on others. The visually challenged persons are capable of maintaining their social life independently.

## VII Future Enhancement:

- o This device can be improved to have more decision-making capabilities by using other types of sensors. So, that it helps to resolve the difficulties faced by them in their day to day life.
- o The system can also be improved to ensure their safety such as obstacle detection, pit hole detection, traffic signal detection before the time they reach there.
- o The system can be effectively designed by adding more machine learning algorithms so that the device can be installed in the phone in a mini version form, which discourages carrying a bulky device.
- o The size of the device can be reduced, for efficient use of the device.

## REFERENCES

- [1] Santiago Real, Alvaro Araujo. Navigation Systems for the Blind and Visually Impaired: Past Work, Challenges, and Open Problems. Sensors (Basel). Published 2019 Aug 2.
- [2] M. Murata, D. Ahmetovic, D. Sato, H. Takagi, K. M. Kitani and C. Asakawa, "Smartphone- based Indoor Localization for Blind Navigation across Building Complexes," 2018 IEEE International Conference on Pervasive Computing and Communications (PerCom), Athens, 2018, pp.
- [3] G. Naveen balaji, S. Anusha and J. Aswini, "GPS based smart navigation for visually impaired using bluetooth 3.0", imperial journal of interdisciplinary research, vol3, issue 3, 2017.
- [4] Md. Mohsinur Rahman Adnan and Towhid Bin Alam, "Design and Implementation of Smart Navigation System for Visually Impaired", International Journal of Engineering Trends and Technology (IJETT) – Volume 58 Issue 2 - April 2018.
- [5] Hwang, Jong-Gyu, Tae-Ki An, Kyeong-Hee Kim, and Chung-Gi Yu. "IoT-Based Route Guidance Technology for the Visually Impaired in Indoor Area." *Smart Mobility-Recent Advances, New Perspectives and Applications*.

- [6] Al-kafaji, Rasha Diaa, Sadik Kamel Gharghan, and Siraj Qays Mahdi. "Localization techniques for blind people in outdoor/indoor environments." In *IOP Conference Series: Materials Science and Engineering*, vol. 745, no. 1, p. 012103. IOP Publishing, 2020.
- [7] Shendge, Rajvardhan, Aditya Patil, and Siddhi Kadu. "Smart Navigation for Visually Impaired people using Artificial Intelligence." In *ITM Web of Conferences*, vol. 44, p. 03053. EDP Sciences, 2022.
- [8] Mueen, Ahmed, Mohammad Awedh, and Bassam Zafar. "Multi-obstacle aware smart navigation system for visually impaired people in fog connected IoT-cloud environment." *Health Informatics Journal* 28, no. 3 (2022): 14604582221112609.
- [9] Blind Assistance System using Image Processing, P. Rama Devi, K. Sahaja, S. Santrupth, M. P. Tony, Harsha, K. Balasubramanyam Reddy, *International Journal for Research in Applied Science & Engineering Technology (IJRASET)*, ISSN: 2321-9653; IC Value: 45.98; SJ Impact Factor: 7.538, Volume 10 Issue III Mar 2022-
- [10] Farzaneh, Mohammad Javadian and Hossein Mahvash Mohammadi. "Implementation of a Blind navigation method in outdoors/indoors areas." *ArXiv* abs/2212.12185 (2022): n. pag.
- [11] Kuriakose, Bineeth, Raju Shrestha, and Frode Eika Sandnes. "Tools and technologies for blind and visually impaired navigation support: a review." *IETE Technical Review* 39, no. 1 (2022): 3-18.
- [12] Owayjan, Michel, Ali Hayek, Hassan Nassrallah, and Mohammad Eldor. "Smart assistive navigation system for blind and visually impaired individuals." In *2015 International Conference on Advances in Biomedical Engineering (ICABME)*, pp. 162-165. IEEE, 2015.
- [13] Wang, Jiaji, Shuihua Wang, and Yudong Zhang. "Artificial intelligence for visually impaired." *Displays* 77 (2023): 102391.
- [14] Mashia, Maisha, Tasmia Ali, Prangon Das, Zinat Tasneem, Md Faisal Rahman Badal, Subrata Kumar Sarker, Md Mehedi Hasan et al. "Towards assisting visually impaired individuals: A review on current status and future prospects." *Biosensors and Bioelectronics: X* 12 (2022): 100265.
- [15] Ullah, Muhib, Shah Khusro, Mumtaz Khan, Iftikhar Alam, Inayat Khan, and Badam Niazi. "Smartphone-Based Cognitive Assistance of Blind People in Room Recognition and Awareness." *Mobile Information Systems* 2022 (2022).
- [16] Walle, Hélène, Cyril De Runz, Barthélemy Serres, and Gilles Venturini. "A survey on recent advances in AI and vision-based methods for helping and guiding visually impaired people." *Applied Sciences* 12, no. 5 (2022): 2308.